

EFFECTIVITY
MODEL: 707-300B/300C
SERVICE BULLETIN
REFERENCE: SB 2999
SSI DOCUMENT (D6-44860)
REFERENCE:
SSD 52-A35-02
SSD 52-A45-02

**BOEING**   
**COMMERCIAL JET**  
**NONDESTRUCTIVE TEST**

PART 2 - X-RAY

DOORS

1. Purpose

- A. To detect cracks in the main cargo door from the lower edge of the steel door hinge downward a minimum of 6 inches. Primary interest is the bottom row of fasteners approximately 1.5 inches below the edge of the cargo door hinge. Particular attention should be given to the skin, frame and frame attachment angle clip at the fastener hole locations common to the outer skin, the frame, and the frame clip.

2. Equipment

- A. The equipment used to develop this technique is as follows:

- (1) Balto 150-kv side emission X-ray generator.

EXPOSURE NUMBER	FILM			SFD	GENERATOR SETTINGS	
	POSITION	ASTM CLASS	SIZE		KV	MAS
1 thru 5	1 thru 5	I	14 x 17	70	135	680

Main Cargo Door Skin - Hinge Area  
Figure 1 (Sheet 1)

Jun 15/81

Part 2  
52-30-07  
Page 1

**BOEING**   
**COMMERCIAL JET**  
**NONDESTRUCTIVE TEST**

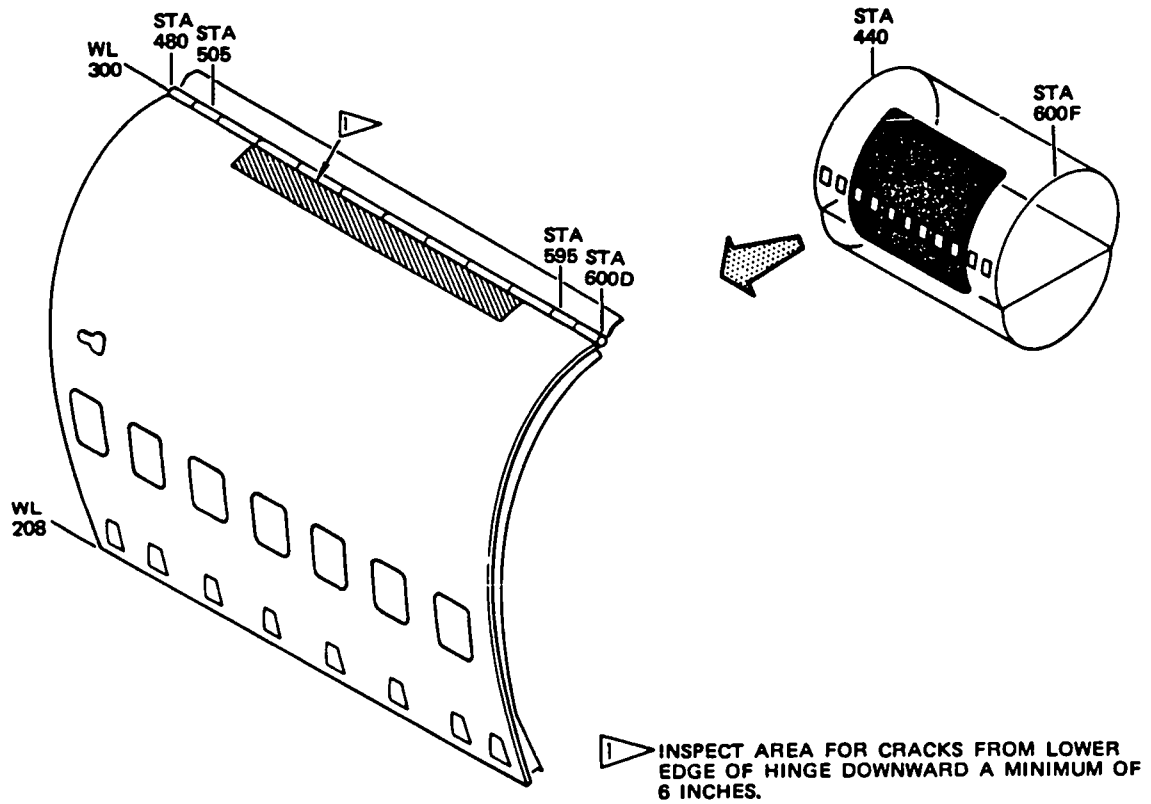

Main Cargo Door Skin - Hinge Area  
Figure 1 (Sheet 2)

**BOEING**  
**COMMERCIAL JET**  
**NONDESTRUCTIVE TEST**

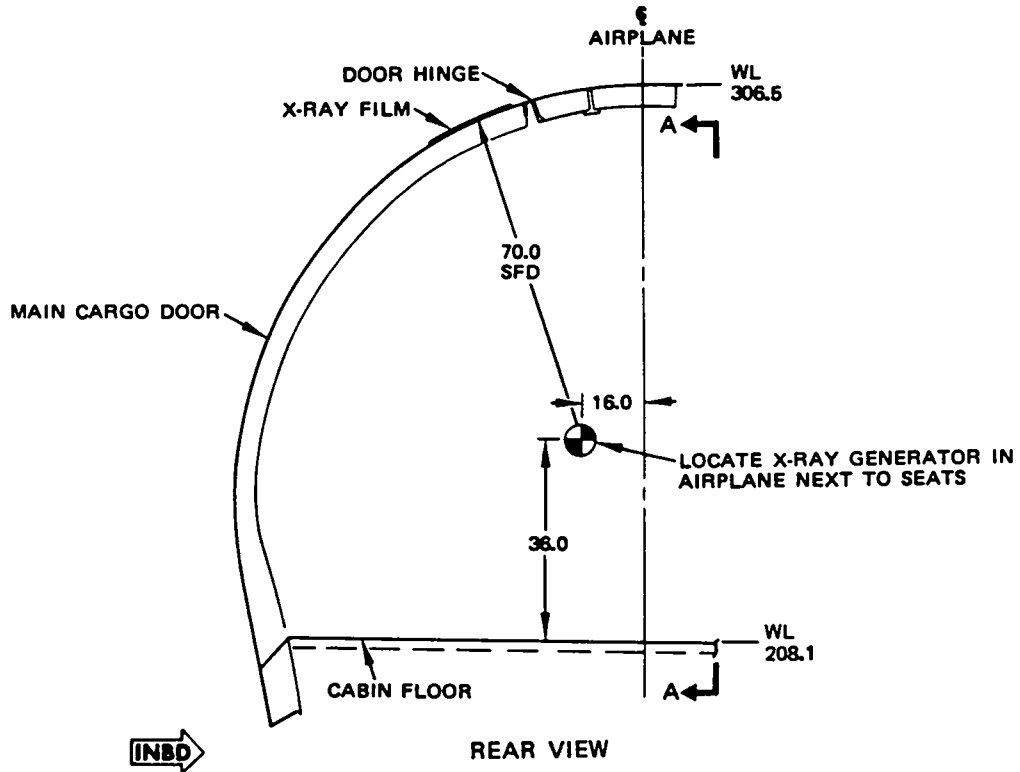

**NOTES**

- ALL DIMENSIONS IN INCHES
- ⊙ X-RAY GENERATOR POSITIONS

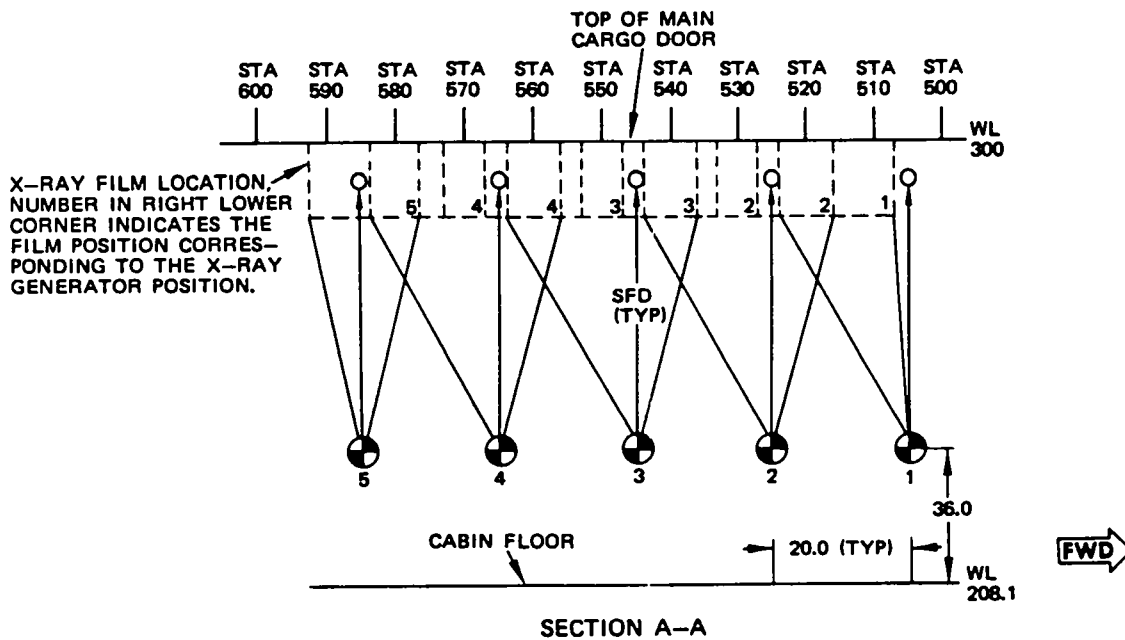

Main Cargo Door Skin - Hinge Area  
 Figure 1 (Sheet 3)

**BOEING**   
**COMMERCIAL JET**  
**NONDESTRUCTIVE TEST**

EFFECTIVITY
MODEL: 707
SSI DOCUMENT (D6-44860)
REFERENCE: SSD 52-A35-02 52-A45-02
SERVICE BULLETIN REFERENCE: 2999

PART 2 - X-RAY

DOORS

1. Purpose

A. To detect cracks in the main cargo door in the area 6 inches above and 3 inches below the center line of stringer 10. Primary interest is the top fasteners where the window skin panel ends at each frame. Particular attention should be given to the skin, frame and frame attachment angle clip at the fastener hole locations common to the outer skin, the frame, and the frame clip.

2. Equipment

A. The equipment used to develop this technique is as follows:

(1) Balto 150-kv side emission X-ray generator.

EXPOSURE NUMBER	FILM			SFD	GENERATOR SETTINGS	
	POSITION	ASTM CLASS	SIZE		KV	MAS
1 thru 5	1 thru 5	I	14 x 17	70	135	680

Main Cargo Door Skin - Stringer 10 Skin Lap  
 Figure 2 (Sheet 1)

**BOEING**   
**COMMERCIAL JET**  
**NONDESTRUCTIVE TEST**

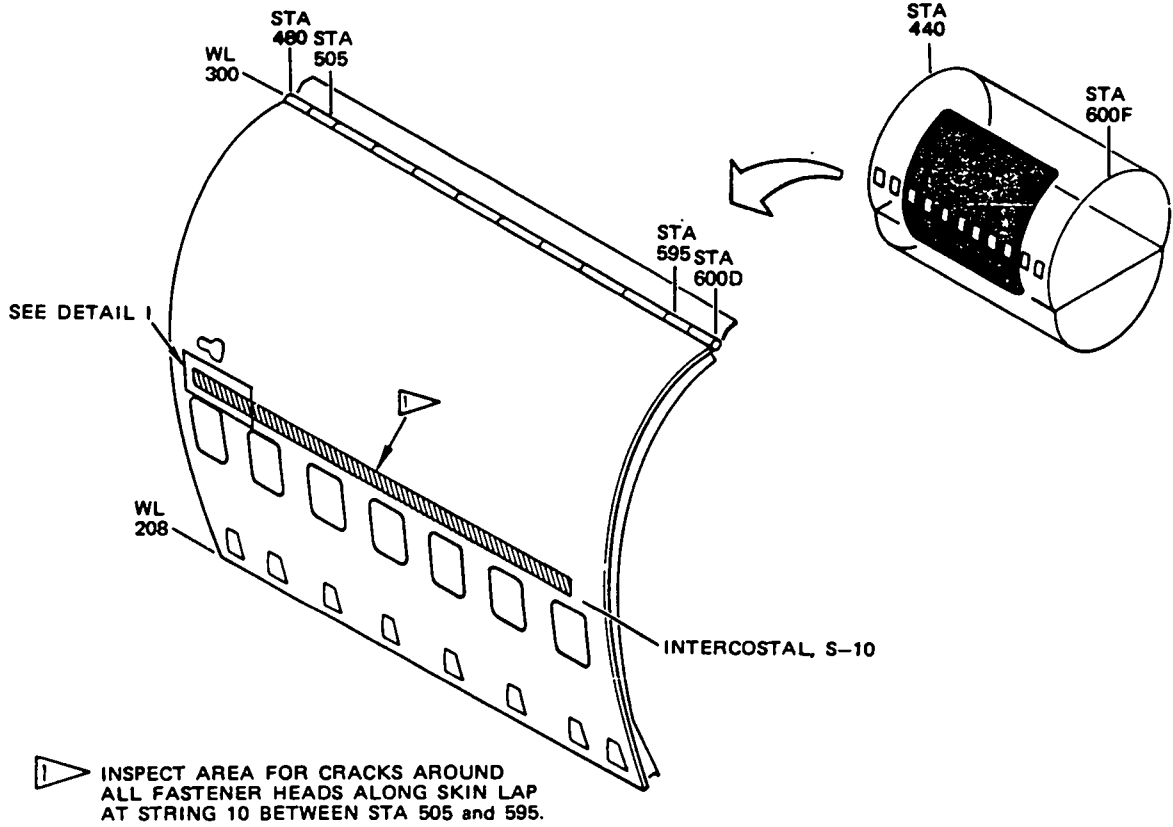

Main Cargo Door Skin - Stringer 10 Skin Lap  
Figure 2 (Sheet 2)

Dec 15/80

**BOEING**  
**COMMERCIAL JET**  
**NONDESTRUCTIVE TEST**

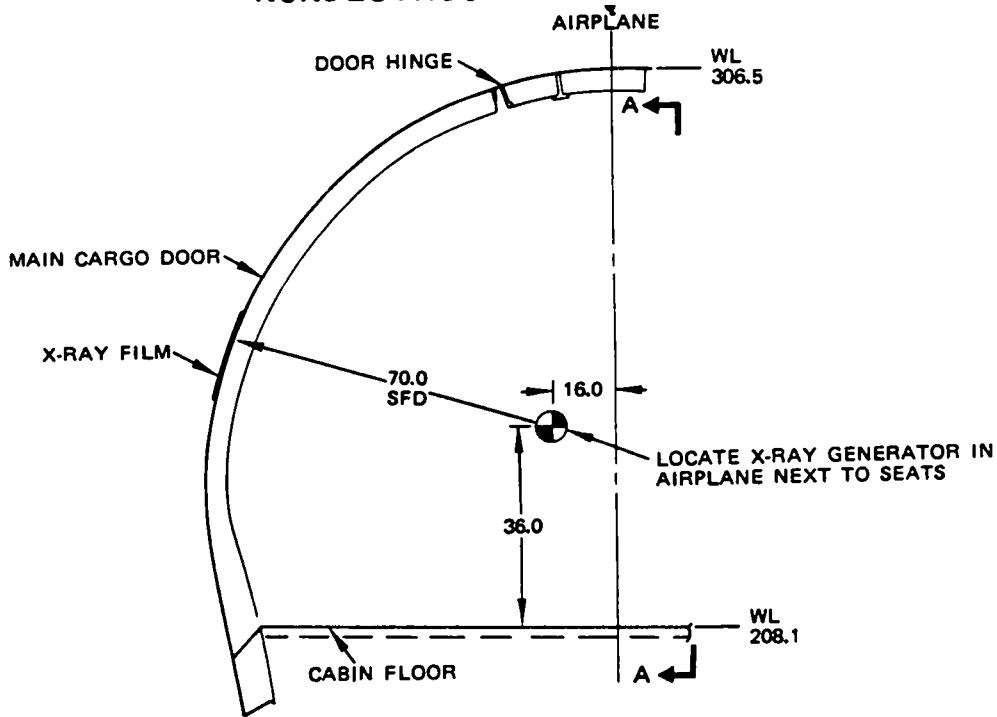

REAR VIEW

NOTES

- ALL DIMENSIONS ARE IN INCHES
- ⊙ X-RAY GENERATOR POSITIONS

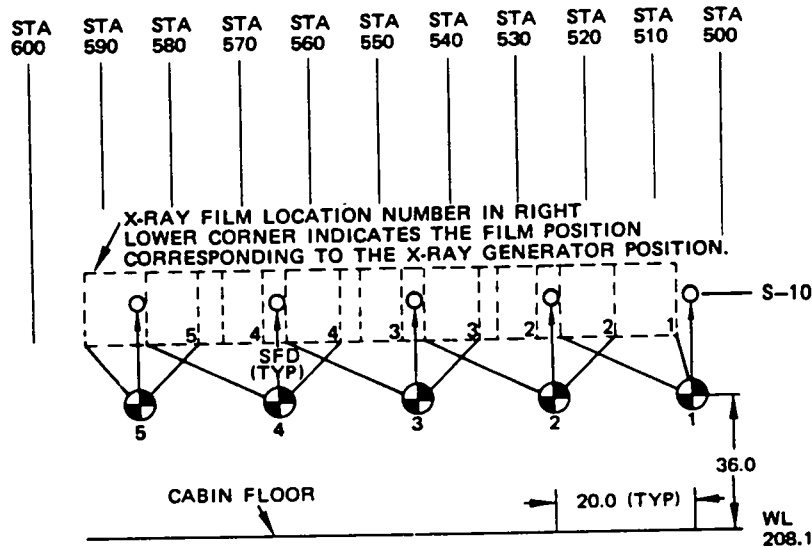

SECTION A-A

Main Cargo Door Skin - Stringer 10 Skin Lap  
 Figure 2 (Sheet 3)

**BOEING**   
**COMMERCIAL JET**  
**NONDESTRUCTIVE TEST**

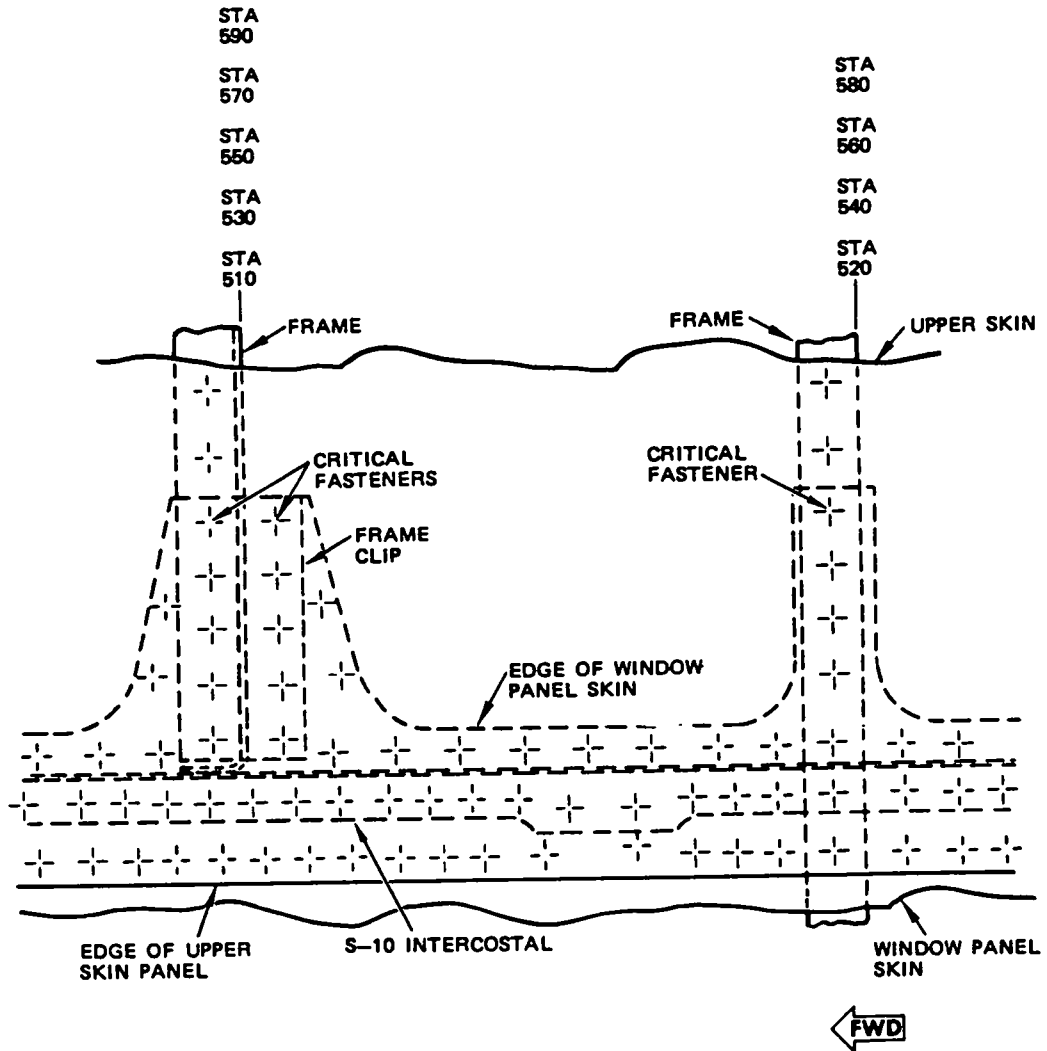

**DETAIL I**  
 (TYPICAL FOR ALL DOOR FRAMES)

Dec 15/80

Main Cargo Door Skin - Stringer 10 Skin Lap  
 Figure 2 (Sheet 4)

Part 2  
 52-30-07  
 Page 7

**BOEING**   
**COMMERCIAL JET**  
**NONDESTRUCTIVE TEST**

EFFECTIVITY	
MODEL:	ALL
SSI DOCUMENT	(D6-48040)
REFERENCE:	
SSD	52-A00-01
	52-A10-01
	52-A20-01
	52-A30-01
	52-A40-01

PART 2 - X-RAY

CARGO DOORS

1. Purpose

- A. To detect cracks propagating from fastener holes common to the skin and horizontal beams of the fuselage lower lobe cargo doors.

2. Equipment

- A. Any X-ray generating equipment capable of satisfying the requirements of this procedure may be used. The following equipment was used during the development of this inspection technique and found acceptable:

(1) Sperry portable 160 kV, side emission X-ray generator.

- B. ASTM Class I and Class II Film

(1) The following film was used during the development of this procedure and found acceptable:

- (a) Class I, Kodak M Type ready pack  
(b) Class II, Kodak AA Type ready pack

3. Preparation for Inspection

- A. Gain access to the lower cargo compartment through the cargo doors.
- B. Remove any external fairings attached to door external skin. (Do not remove fairing support angles.)
- C. Turn handle, with door open, to closed position and remove inner handle from post.

Cargo Door Beams  
Figure 3 (Sheet 1)

**BOEING**   
**COMMERCIAL JET**  
**NONDESTRUCTIVE TEST**

4. Inspection Procedure

- A. Refer to Detail I for airplane effectivity and inspection Details for aft, center and forward cargo door.
- B. Position X-ray generator and place film per appropriate Detail.
- C. Set X-ray generator controls and make exposures using values in appropriate X-ray Parameter Table.
- D. Review film, paying particular attention to cracks out of fastener holes common to the door horizontal beams and skin.

NOTE: End fasteners common to skin and horizontal beams at door stops may not be inspectable due to radiographic interference by the door stop fittings.

EXPOSURE NUMBER	FILM			SFD	GENERATOR SETTINGS	
	POSITION ▷	ASTM CLASS	SIZE		KV	MAS
1	1, 2	I, II	14 X 17	56	90	525
2	1, 2	I, II	14 X 17	56	90	525
3	1, 2	I, II	14 X 17	56	90	525
4	1	I, II	14 X 17	60	90	525
5	1	I, II	14 X 17	60	90	525
6	1	I, II	14 X 17	60	90	525
7	1	I, II	14 X 17	60	90	525

X-RAY PARAMETERS - AFT CARGO DOOR  
TABLE I

NOTES

- ALL DIMENSIONS ARE IN INCHES

▷ SEE DETAIL II FOR GENERATOR LOCATIONS AND FILM POSITIONS

▷ SEE DETAIL I FOR AIRPLANE EFFECTIVITY

Cargo Door Beams  
Figure 3 (Sheet 2)

**BOEING**   
**COMMERCIAL JET**  
**NONDESTRUCTIVE TEST**

EXPOSURE NUMBER	FILM			SFD	GENERATOR SETTINGS	
	POSITION	ASTM CLASS	SIZE		KV	MAS
1	1, 2	I, II	14 X 17	60	90	682
2	1, 2	I, II	14 X 17	60	90	682
3	1, 2	I, II	14 X 17	60	90	682
4	1, 2	I, II	14 X 17	60	90	682
5	1, 2	I, II	14 X 17	60	90	682
6	1, 2	I, II	14 X 17	60	90	682
7	1, 2	I, II	14 X 17	60	90	682
8	1, 2	I, II	14 X 17	60	90	682

X-RAY PARAMETERS - CENTER CARGO DOORS  
TABLE II

NOTES:

- ALL DIMENSIONS ARE IN INCHES
- SEE DETAIL I FOR AIRPLANE EFFECTIVITY
- SEE DETAIL III AND IV FOR FILM AND X-RAY GENERATOR POSITION.

EXPOSURE NUMBER	FILM			SFD	GENERATOR SETTINGS	
	POSITION	ASTM CLASS	SIZE		KV	MAS
1	1 & 2	I & II	14 X 17	60	90	682
2	1 & 2	I & II	14 X 17	60	90	682
3	2	I & II	14 X 17	60	90	682
4	1	I & II	14 X 17	60	90	682
	2 & 3	I & II	10 X 12	60	90	682
5	1 & 2	I & II	14 X 17	60	90	682
6	1	I & II	14 X 17	60	90	682
	2 & 3	I & II	4 1/2 X 17	60	90	682
7	1	I & II	11 X 14	60	90	682
	2	I & II	4 1/2 X 17	60	90	682
8	1	I & II	11 X 14	60	90	682
9	1 & 2	I & II	10 X 12	60	90	682
10	1 & 2	I & II	11 X 14	60	90	682

X-RAY PARAMETERS - CENTER CARGO DOORS  
TABLE III

NOTES:

- ALL DIMENSIONS ARE IN INCHES
- SEE DETAIL I FOR AIRPLANE EFFECTIVITY
- SEE DETAIL III AND V FOR FILM AND X-RAY GENERATOR POSITION.



Cargo Door Beams  
Figure 3 (Sheet 3)

**BOEING**   
**COMMERCIAL JET**  
**NONDESTRUCTIVE TEST**

EXPOSURE NUMBER	FILM			SFD	GENERATOR SETTINGS	
	POSITION	ASTM CLASS	SIZE		KV	MAS
						
1	1, 2	I, II	14 X 17	60	90	682
2	1, 2	I, II	14 X 17	60	90	682
3	1, 2	I, II	14 X 17	60	90	682
4	1, 2	I, II	14 X 17	60	90	682
5	1, 2	I, II	14 X 17	60	90	682
6	1	I, II	14 X 17	60	90	682
7	1	I, II	14 X 17	60	90	682
8	1	I, II	14 X 17	60	90	682
9	1	I, II	14 X 17	60	90	682
10	1	I, II	14 X 17	60	90	682

X-RAY PARAMETERS - FORWARD CARGO DOORS  
TABLE IV

NOTES

- ALL DIMENSIONS ARE IN INCHES
-  SEE DETAIL I FOR AIRPLANE EFFECTIVITY
-  SEE DETAILS III AND VI FOR FILM AND X-RAY GENERATOR POSITIONS.

Cargo Door Beams  
Figure 3 (Sheet 4)

**BOEING**  
**COMMERCIAL JET**  
**NONDESTRUCTIVE TEST**

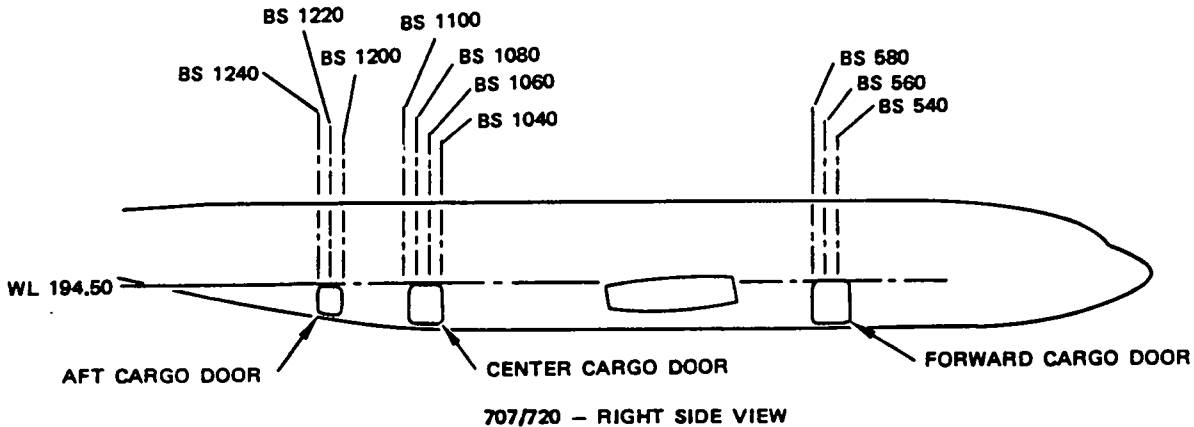

**NOTES**

**AFT CARGO DOOR** 6

- SEE TABLE I FOR EXPOSURE GUIDE
- SEE DETAIL II FOR FILM PLACEMENT AND X-RAY GENERATOR POSITIONS

6 AFT CARGO DOOR IS PRESENT ON THE FOLLOWING AIRPLANES:  
 CUM LINE NOS 1 THRU 17, 20, 25, 26, 30, 31, 33, 36 THRU 37,  
 40 THRU 42, 45, 47, 49, 50 THRU 53, 56 THRU 58, 61 THRU 63,  
 66 THRU 68, 70 THRU 72, 75 THRU 78, 81 THRU 84, 87, 90 THRU 94,  
 96 THRU 102, 105 THRU 108, 110 THRU 115, 118, 119, 121, 122, 126  
 THRU 129, 133, 134, 138, 139, 140, 144, 15 145, 151 THRU 155, 159  
 THRU 164, 167 THRU 171, 175, 176, 192, 197, 200, 204, 205, 209, 213,  
 216, 217, 221, 225, 232 THRU 236, 239 THRU 242, 246 THRU 248, 254,  
 255, 264, 266, 268 THRU 272, 274 THRU 276, 282, 283, 287, 292, 293,  
 302, 303, 307, 310, 314, 325, 327 THRU 330, 332, 334 THRU 339, 341  
 THRU 346, 348 THRU 350, 352 THRU 358, 382, 364 THRU 379, 383,  
 386, 387, 389, 390, 394, 397, 401 THRU 413, 416 THRU 423, 425 THRU  
 434, 438 THRU 441, 443 THRU 445, 447 THRU 453, 456, 458, 459, 463,  
 466, 467, 472, 475, 477, 478, 480, 481, 484, 488, 490, 491, 493 THRU  
 496, 497 THRU 529, 531 THRU 535, 537 THRU 557, 580 THRU 563, 565,  
 566, 570 THRU 572, 574 THRU 576, 578 THRU 582, 584, 586 THRU 597,  
 599 THRU 605, 608 THRU 668, 670 THRU 673, 675 THRU 679, 681  
 THRU 684, 686, 688 THRU 703, 705 THRU 765, 767 THRU 770, 774  
 THRU 776, 778 THRU 783, 786 THRU 788, 794 THRU 798, 800, 801, 803  
 THRU 809, 811, 813 THRU 897, 899, 900, 903, 905, 906, 908, 910 THRU  
 912, 914, 915, 917 THRU 919, 922, 923, 925, 928 AND 929

**CENTER CARGO DOOR** 7

- SEE TABLES II FOR EXPOSURE GUIDE FOR 8 A/P'S
- SEE DETAIL III FOR X-RAY GENERATOR POSITION
- SEE DETAIL IV FOR FILM PLACEMENT AND GENERATOR ALIGNMENT POINTS FOR 8 A/P'S

7 CENTER CARGO DOOR AND FORWARD CARGO DOOR ARE PRESENT ON ALL AIRPLANES

**FORWARD CARGO DOOR** 9

- SEE TABLE III FOR EXPOSURE GUIDE FOR 9 A/P'S
- SEE DETAIL V FOR FILM PLACEMENT AND GENERATOR ALIGNMENT POINTS FOR 9 A/P'S
- SEE TABLE IV FOR EXPOSURE GUIDE
- SEE DETAIL III FOR X-RAY GENERATOR POSITION
- SEE DETAIL VI FOR FILM PLACEMENT AND GENERATOR ALIGNMENT POINTS

8 CUM LINE NOS 1-12, 14-19, 21 THRU 28, 30 THRU 32, 34,  
 36 THRU 38, 41 THRU 43, 45, 46, 48 THRU 53, 55 THRU 57,  
 63, 66, 67, 72, 77, 87, 0 96, 97, 102, 10 140, , 277, 280, 286, 291,  
 294, 296, 299, 301, 306, 308, 309, 311, 312, 391 THRU 393, 395 THRU  
 396, 420, 422, 426, 432, 479, 486, 489, 490 THRU 493, 506, 526, 530,  
 533, 535, 539, 558, 562, 564, 565, 567, 569, 571, 573, 575, 577, 579,  
 583, 586, 589, 591, 593, 595, 598, 600, 602, 604, 622, 682, , 787, 794,  
 AND 801, AND ALL 720 AIRPLANES

9 ALL AIRPLANES EXCEPT 8

X-RAY INSPECTION AND EFFECTIVITY LOCATOR  
 DETAIL I

Cargo Door Beams  
 Figure 3 (Sheet 5)

**BOEING**   
**COMMERCIAL JET**  
**NONDESTRUCTIVE TEST**

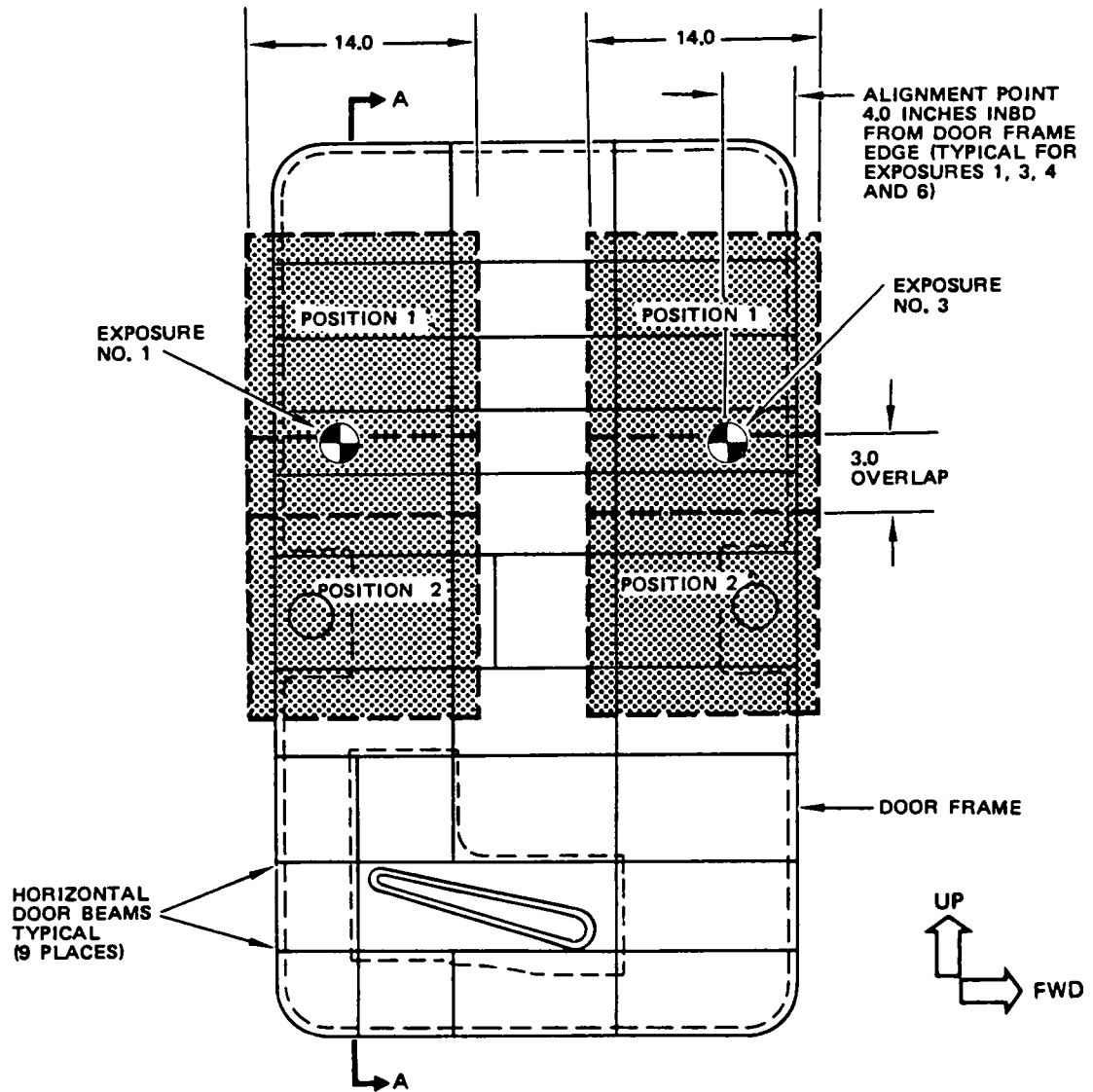

PLAN VIEW – LOOKING IN  
 BASIC INTERNAL STRUCTURE

**NOTES**

- SEE DETAIL I FOR A/P EFFECTIVITY
- SEE TABLE I FOR X-RAY PARAMETERS
- ALL DIMENSIONS ARE IN INCHES

 X-RAY GENERATOR

 FILM COVERAGE (14X17 FILM)

FILM AND X-RAY GENERATOR LOCATIONS  
 AFT CARGO DOOR



DETAIL II

Cargo Door Beams  
 Figure 3 (Sheet 6)

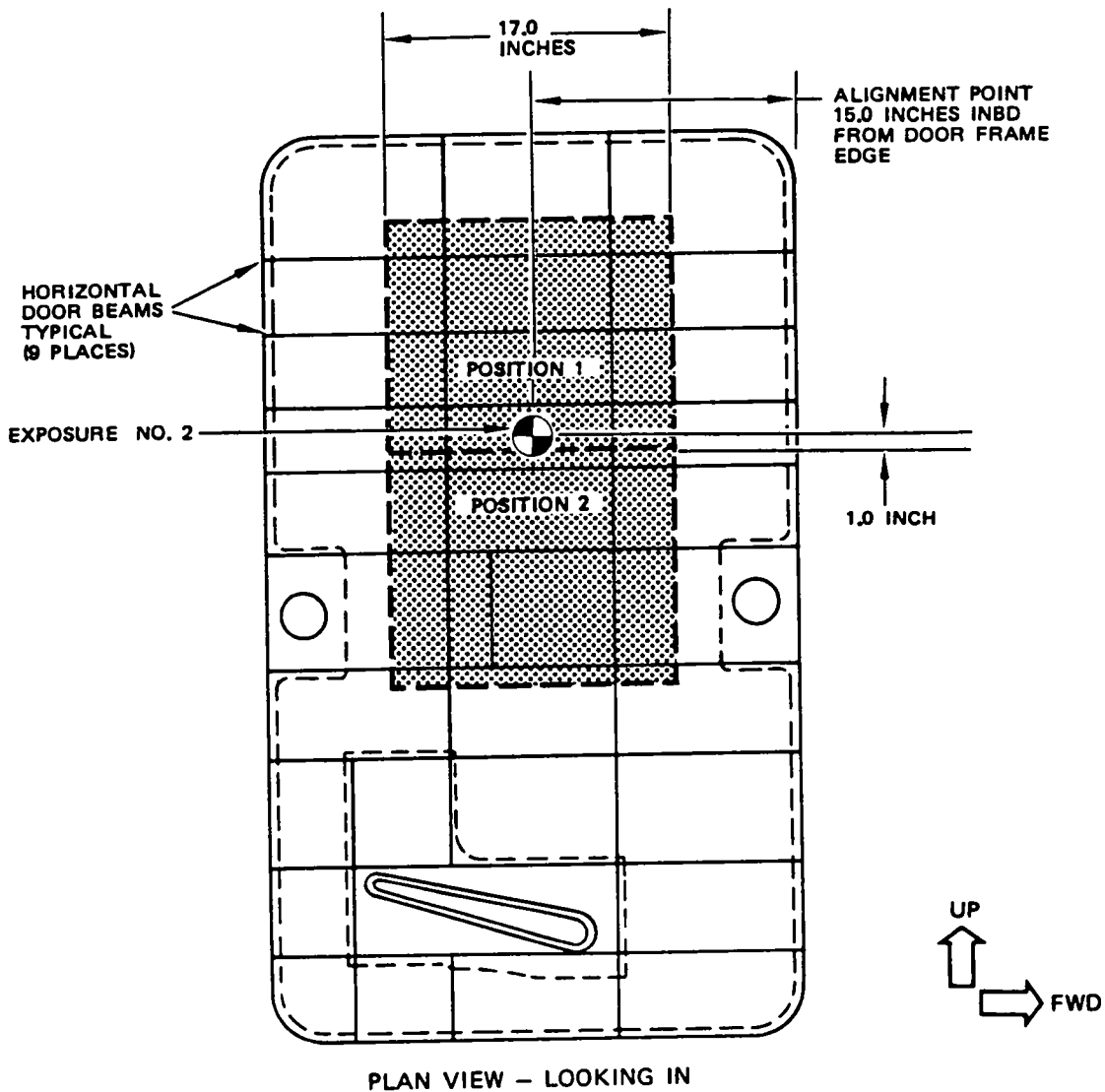
**BOEING**   
**COMMERCIAL JET**  
**NONDESTRUCTIVE TEST**



**NOTES**

- SEE DETAIL I FOR A/P EFFECTIVITY
- SEE TABLE I FOR X-RAY PARAMETERS
- ALL DIMENSIONS ARE IN INCHES
-  X-RAY GENERATOR
-  FILM COVERAGE (14 X 17 FILM)

FILM AND X-RAY GENERATOR LOCATIONS  
 AFT CARGO DOOR  
 DETAIL II (CONT)

Cargo Door Beams  
 Figure 3 (Sheet 7)

**BOEING**   
**COMMERCIAL JET**  
**NONDESTRUCTIVE TEST**

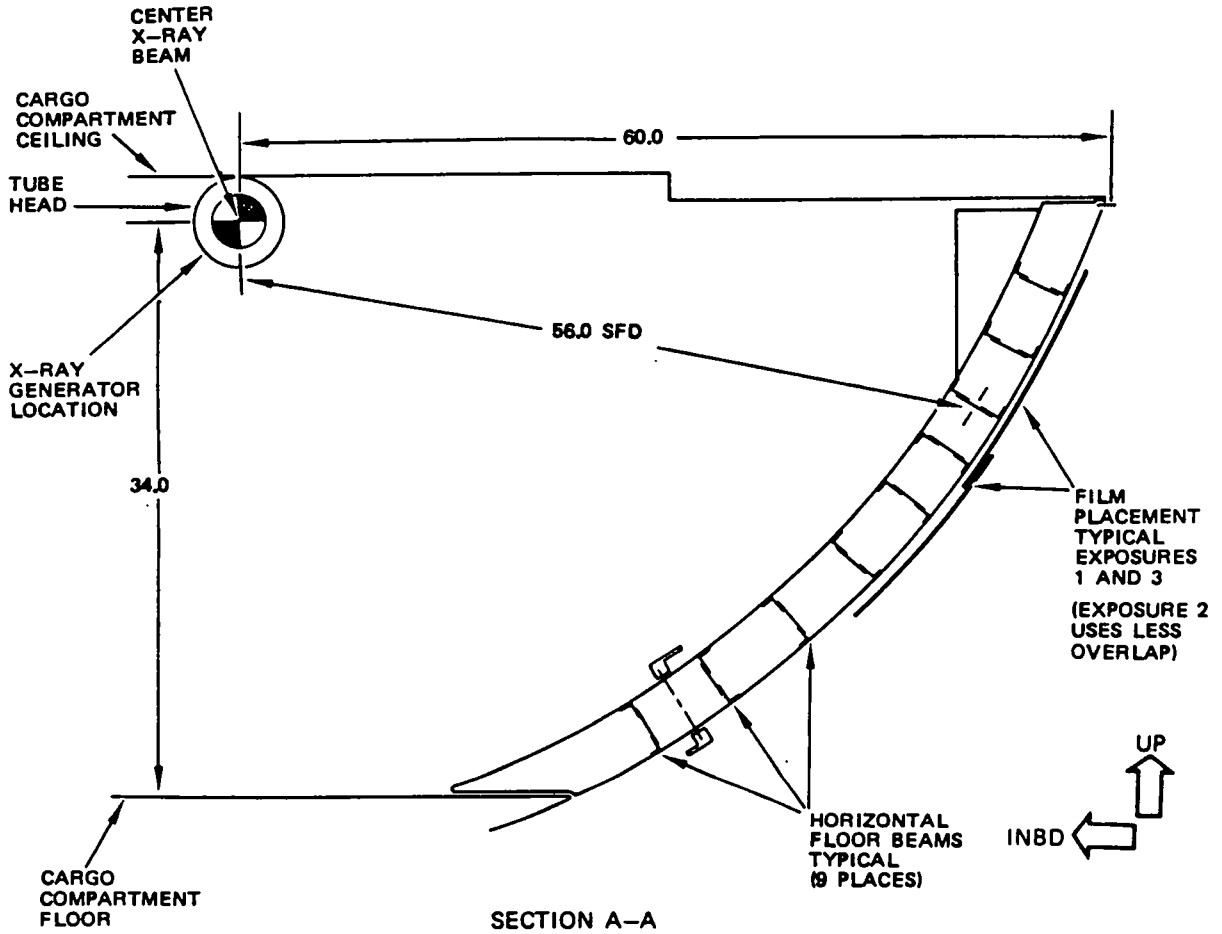

**NOTES**

- SEE DETAIL I FOR A/P EFFECTIVITY
- SEE TABLE I FOR X-RAY PARAMETERS
- ALL DIMENSIONS ARE IN INCHES

 X-RAY GENERATOR

FILM AND X-RAY GENERATOR LOCATIONS  
 AFT CARGO DOOR 

DETAIL II (CONT)

Cargo Door Beams  
 Figure 3 (Sheet 8)

**BOEING**   
**COMMERCIAL JET**  
**NONDESTRUCTIVE TEST**

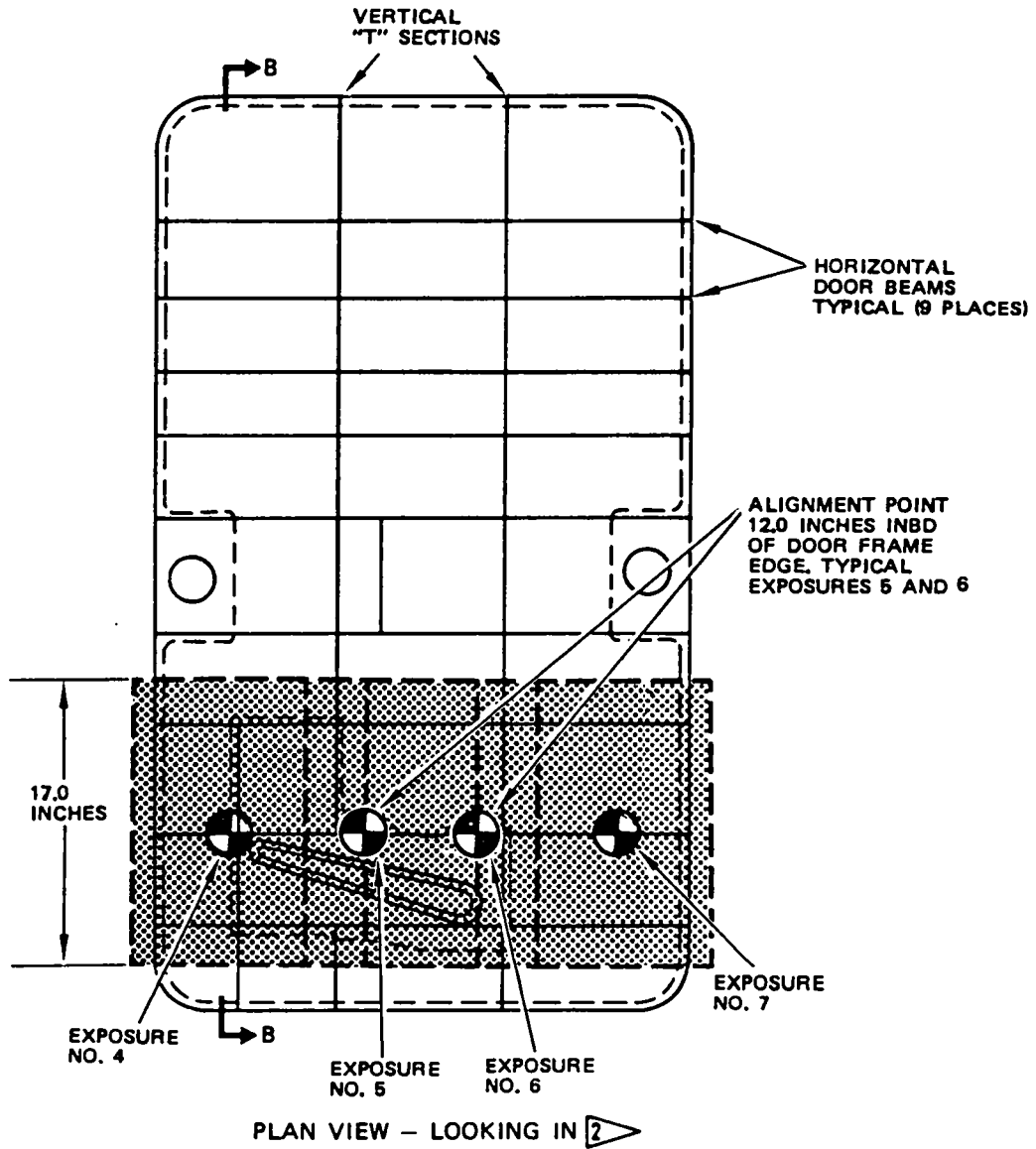

**NOTES**

- SEE DETAIL I FOR A/P EFFECTIVITY
- SEE TABLE I FOR X-RAY PARAMETERS
- ALL DIMENSIONS ARE IN INCHES

 X-RAY GENERATOR  
 FILM COVERAGE

FILM AND X-RAY GENERATOR LOCATION  
 AFT CARGO DOOR  
 DETAIL II (CONT)

Cargo Door Beams  
 Figure 3 (Sheet 9)

**BOEING**   
**COMMERCIAL JET**  
**NONDESTRUCTIVE TEST**

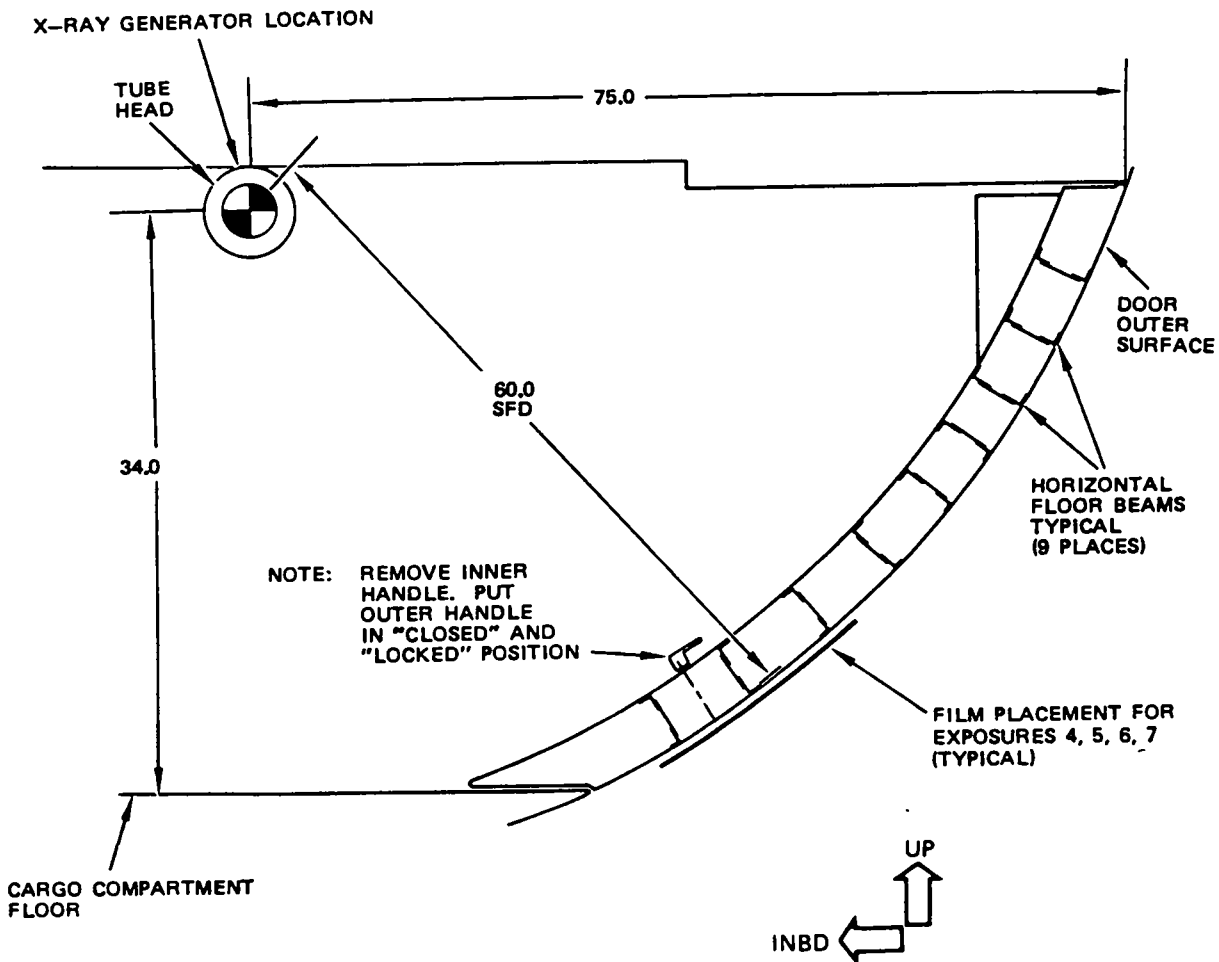

SECTION B-B

NOTES

- SEE DETAIL I FOR A/P EFFECTIVITY
- SEE TABLE I FOR X-RAY PARAMETERS
- ALL DIMENSIONS ARE IN INCHES



X-RAY GENERATOR

FILM AND X-RAY GENERATOR LOCATION  
 AFT CARGO DOOR   
 DETAIL II (CONT)

Cargo Door Beams  
 Figure 3 (Sheet 10)

**BOEING**   
**COMMERCIAL JET**  
**NONDESTRUCTIVE TEST**

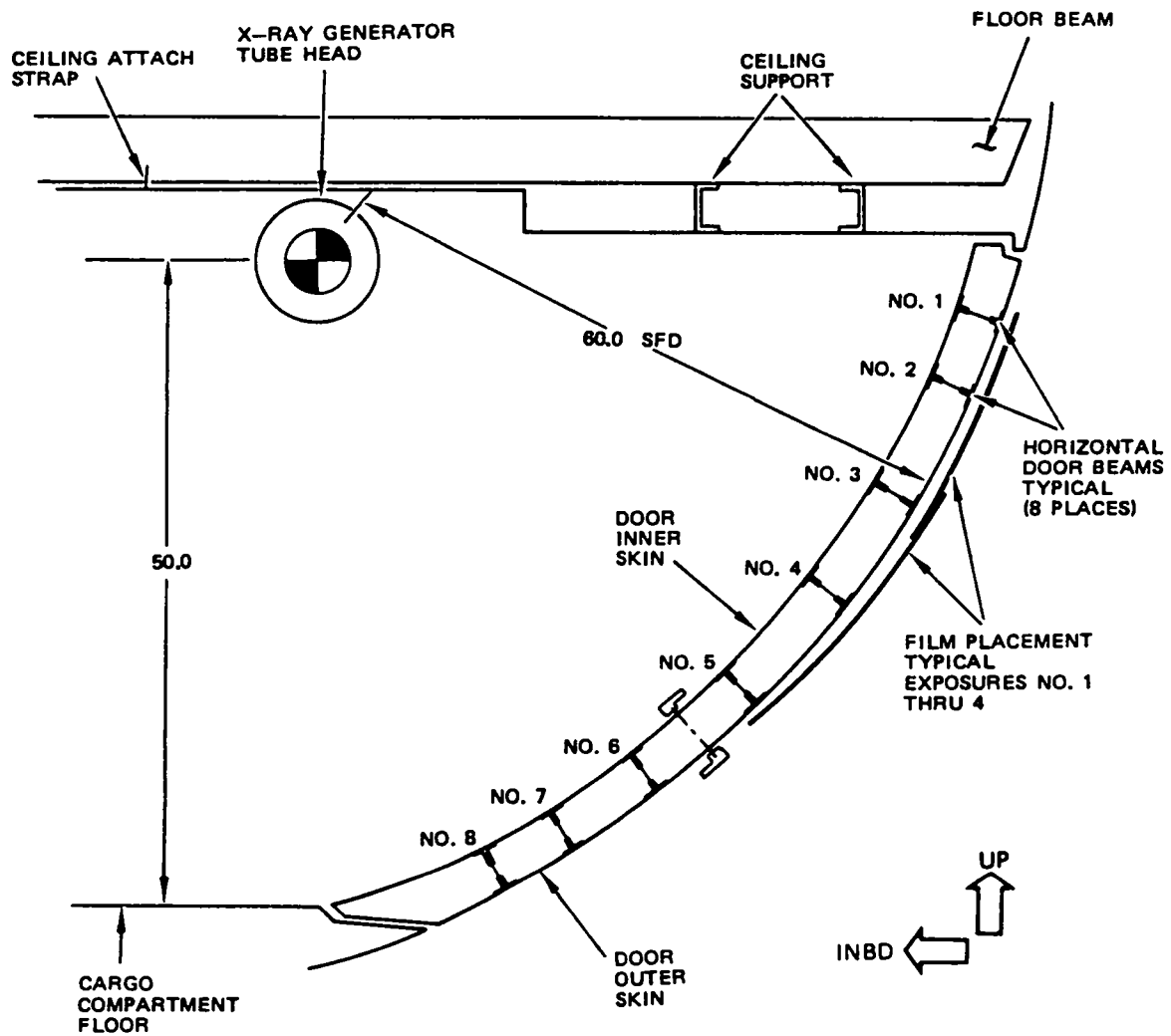

**NOTES**

- SEE TABLE II FOR X-RAY PARAMETERS
- ALL DIMENSIONS ARE IN INCHES

 X-RAY GENERATOR

X-RAY GENERATOR LOCATION CENTER AND FORWARD LOWER LOBE, CARGO DOORS

DETAIL III

Cargo Door Beams  
 Figure 3 (Sheet 11)

**BOEING**   
**COMMERCIAL JET**  
**NONDESTRUCTIVE TEST**

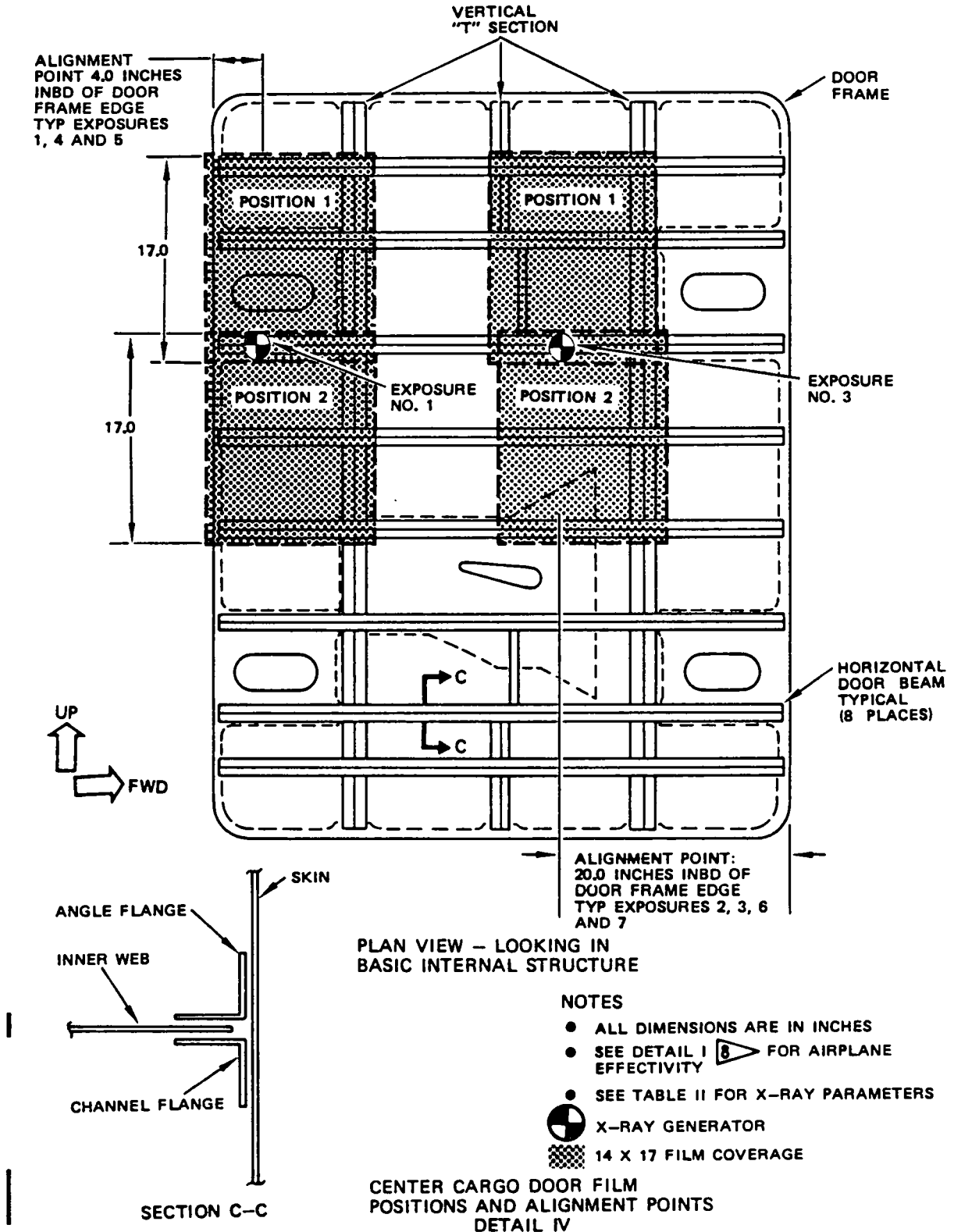

Cargo Door Beams  
 Figure 3 (Sheet 12)

**BOEING**   
**COMMERCIAL JET**  
**NONDESTRUCTIVE TEST**

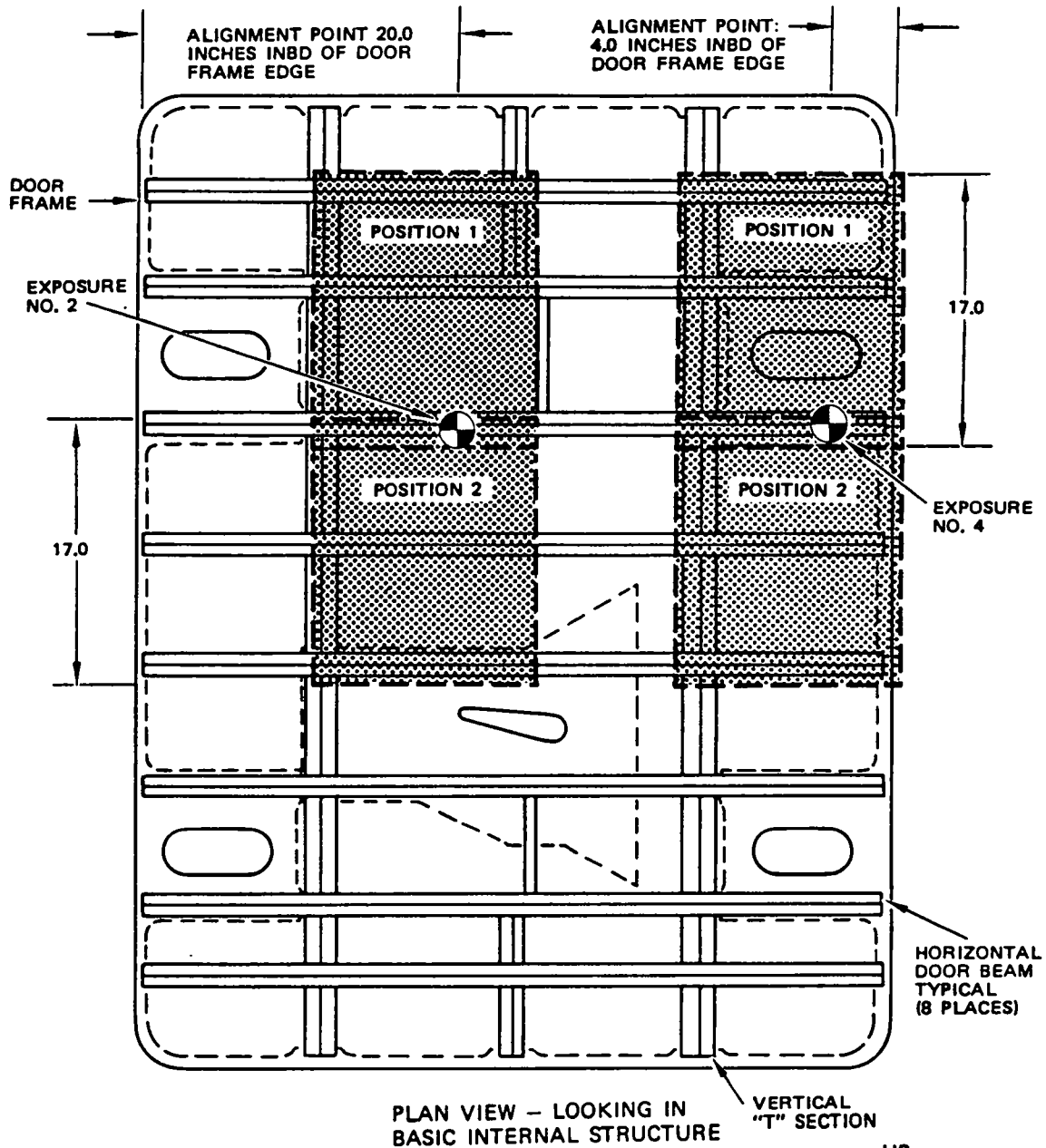

**NOTES**

- ALL DIMENSIONS ARE IN INCHES
- SEE DETAIL I  FOR A/P EFFECTIVITY
- SEE TABLE II FOR X-RAY PARAMETERS

 X-RAY GENERATOR

 14 X 17 FILM COVERAGE

CENTER CARGO DOOR FILM  
 POSITIONS AND ALIGNMENT POINTS  
 DETAIL IV (CONT)

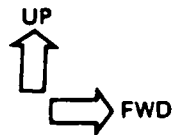

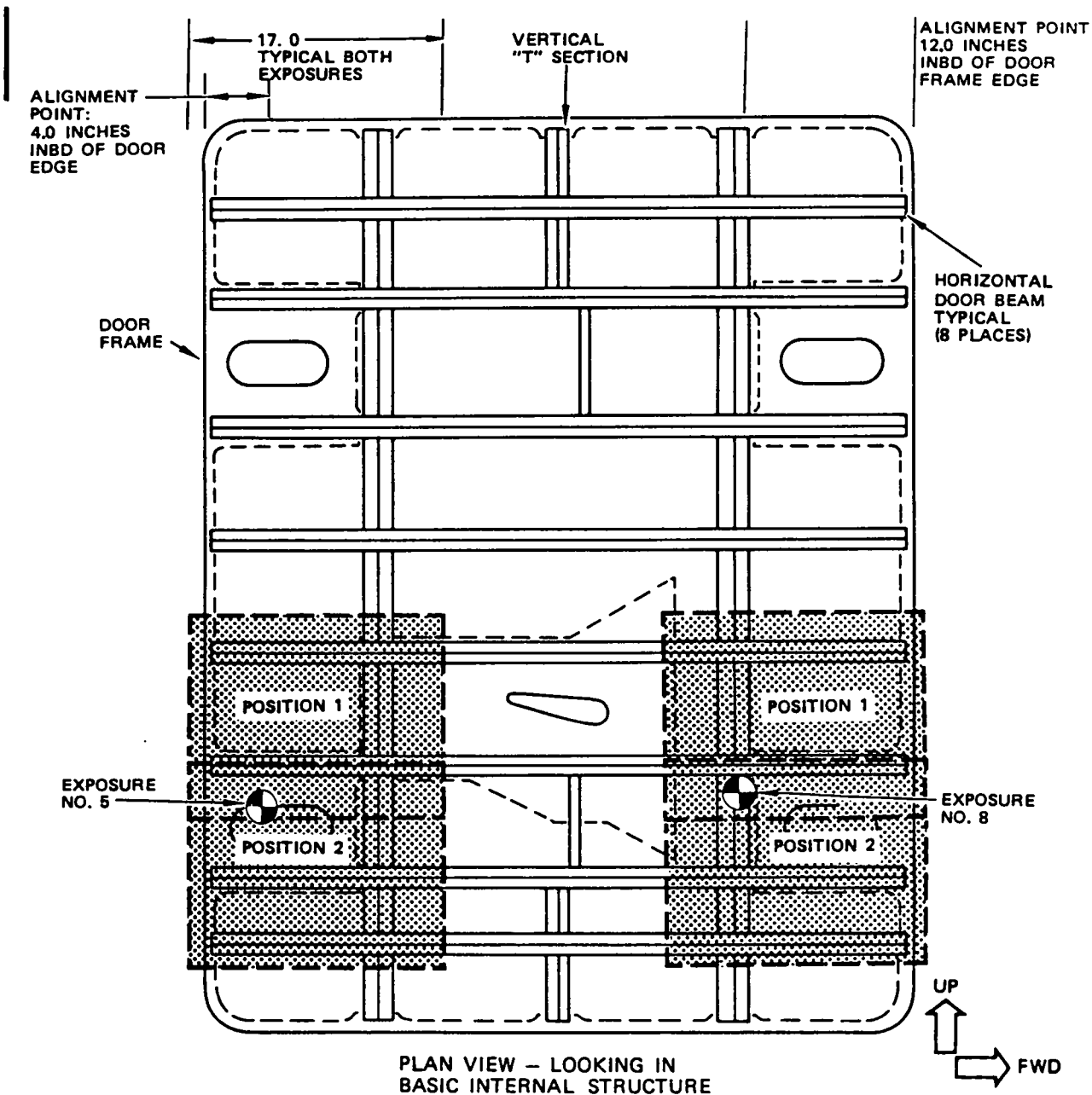

Cargo Door Beams  
 Figure 3 (Sheet 13)

**BOEING**   
**COMMERCIAL JET**  
**NONDESTRUCTIVE TEST**



PLAN VIEW - LOOKING IN  
 BASIC INTERNAL STRUCTURE

**NOTES**

- ALL DIMENSIONS ARE IN INCHES
- SEE DETAIL I  FOR A/P EFFECTIVITY
- SEE TABLE II FOR X-RAY PARAMETERS
-  X-RAY GENERATOR
-  14 X 17 FILM COVERAGE



CENTER CARGO DOOR FILM  
 POSITIONS AND ALIGNMENT POINTS  
 DETAIL IV (CONT)

Cargo Door Beams  
 Figure 3 (Sheet 14)

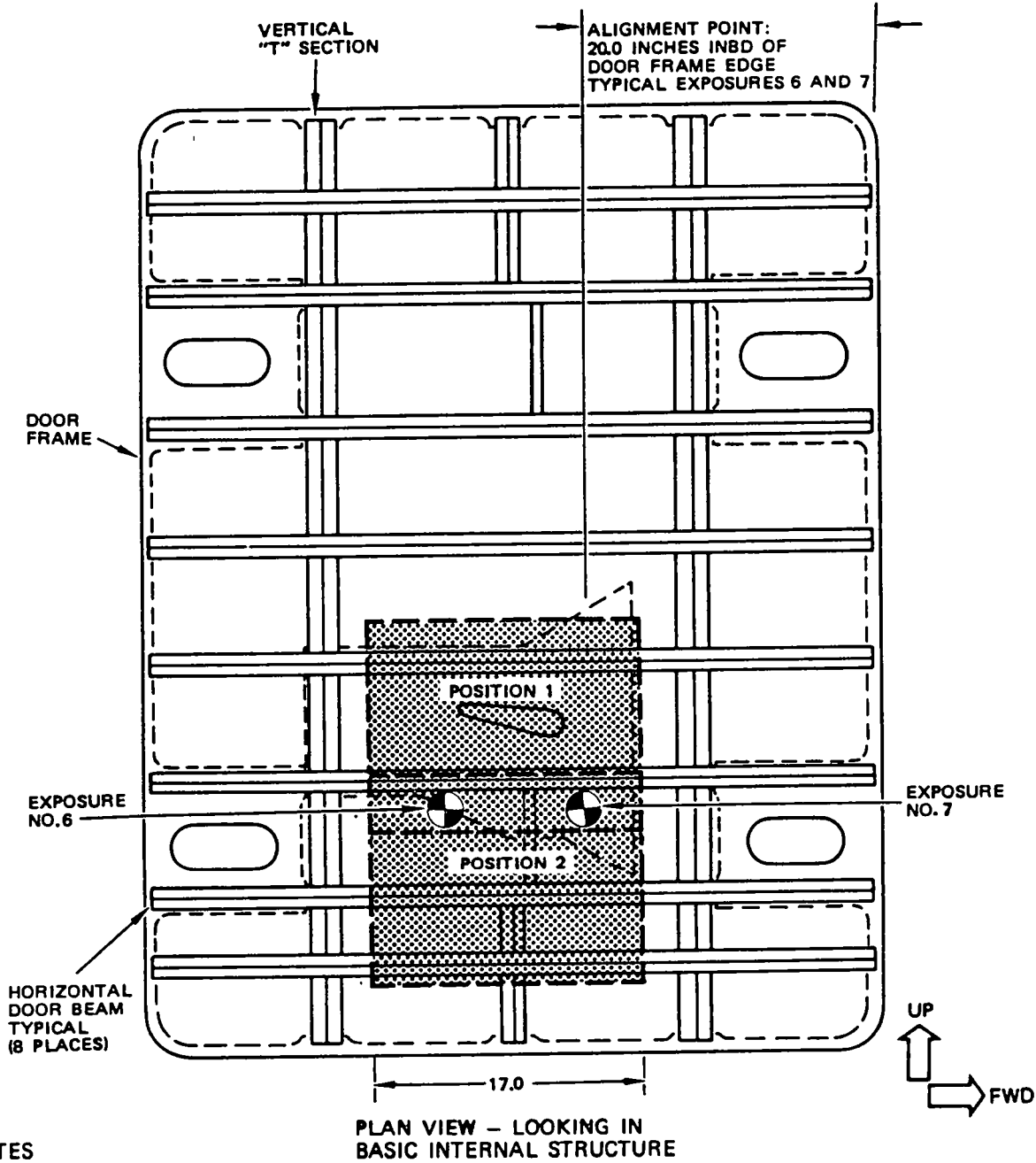
**BOEING**   
**COMMERCIAL JET**  
**NONDESTRUCTIVE TEST**



**NOTES**

- ALL DIMENSIONS ARE IN INCHES
- SEE DETAIL I  FOR A/P EFFECTIVITY
- SEE TABLE II FOR X-RAY PARAMETERS
-  X-RAY GENERATOR LOCATION
-  14 X 17 FILM COVERAGE

**CENTER CARGO DOOR FILM  
 POSITIONS AND ALIGNMENT POINTS  
 DETAIL IV (CONT)**

Cargo Door Beams  
 Figure 3 (Sheet 15)

**BOEING**   
**COMMERCIAL JET**  
**NONDESTRUCTIVE TEST**

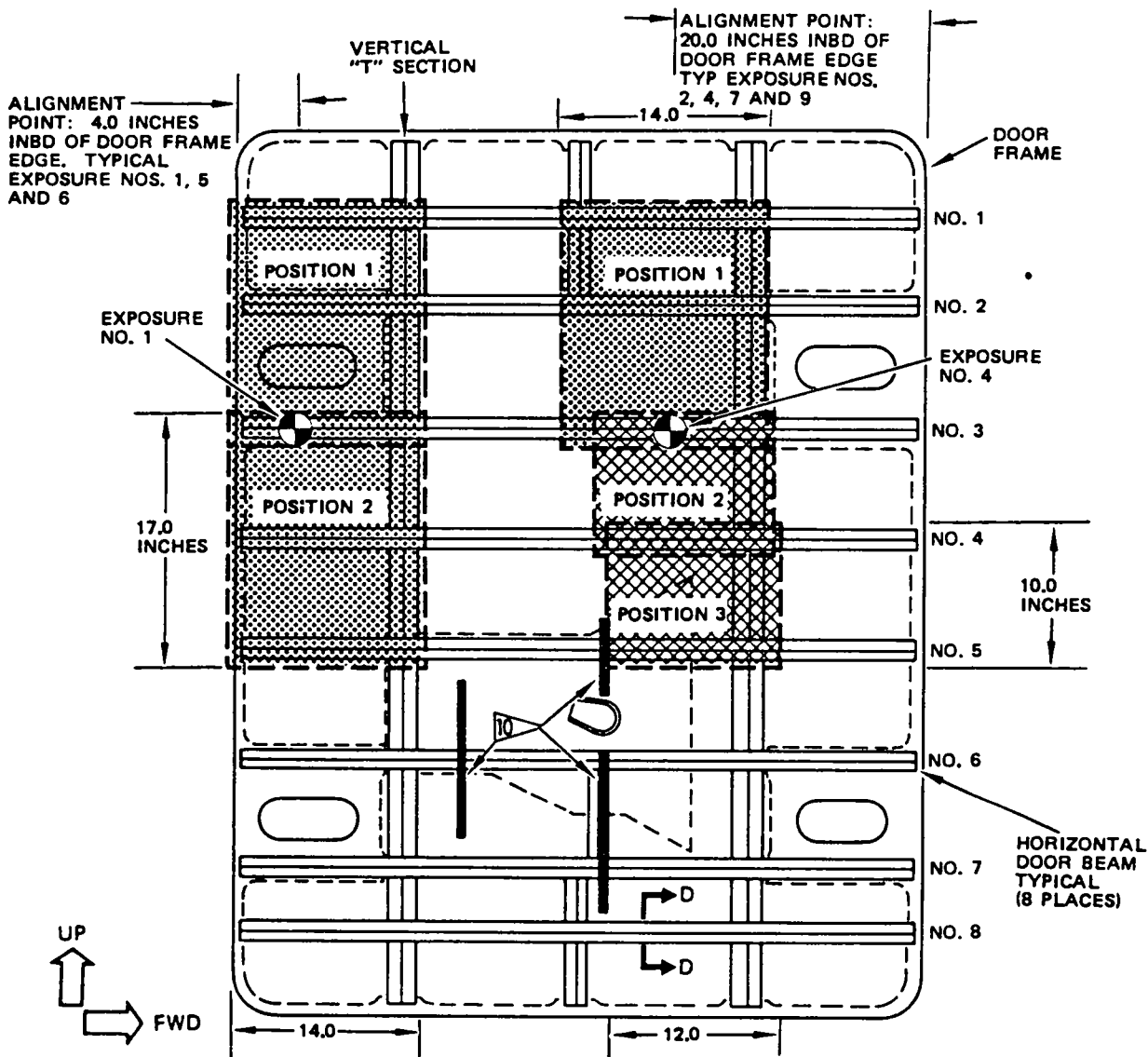



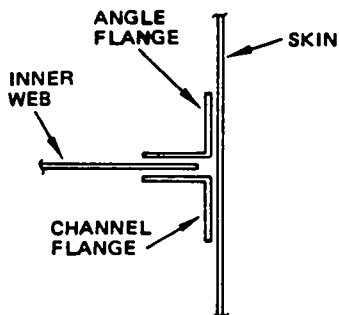

PLAN VIEW - LOOKING IN  
BASIC INTERNAL STRUCTURE



SECTION D-D

**NOTES**

- ALL DIMENSIONS ARE IN INCHES
- SEE DETAIL I  FOR A/P EFFECTIVITY
- SEE TABLE III FOR X-RAY PARAMETERS
-  X-RAY GENERATOR
-  14 X 17 FILM COVERAGE
-  10 X 12 FILM COVERAGE
-  EXTERNAL FAIRING SUPPORTS

CENTER CARGO DOOR FILM  
POSITIONS AND ALIGNMENT POINTS  
DETAIL V

Cargo Door Beams  
Figure 3 (Sheet 16)

**BOEING**  
**COMMERCIAL JET**  
**NONDESTRUCTIVE TEST**

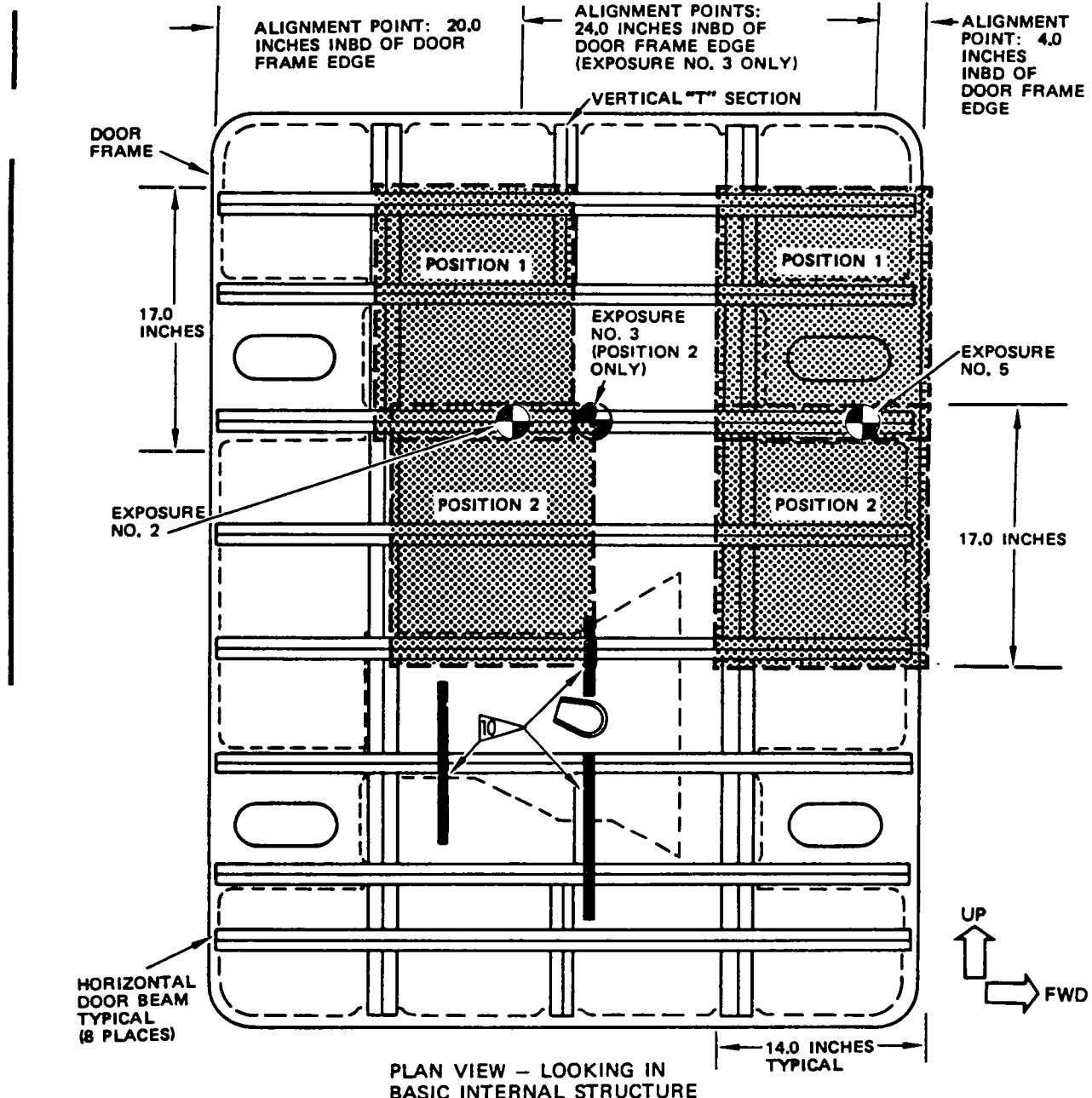

PLAN VIEW - LOOKING IN  
 BASIC INTERNAL STRUCTURE

**NOTES**

- ALL DIMENSIONS ARE IN INCHES
- SEE DETAIL I  FOR A/P EFFECTIVITY
- SEE TABLE III FOR X-RAY PARAMETERS
-  X-RAY GENERATOR
-  14 X 17 FILM COVERAGE
-  EXTERNAL FAIRING SUPPORT





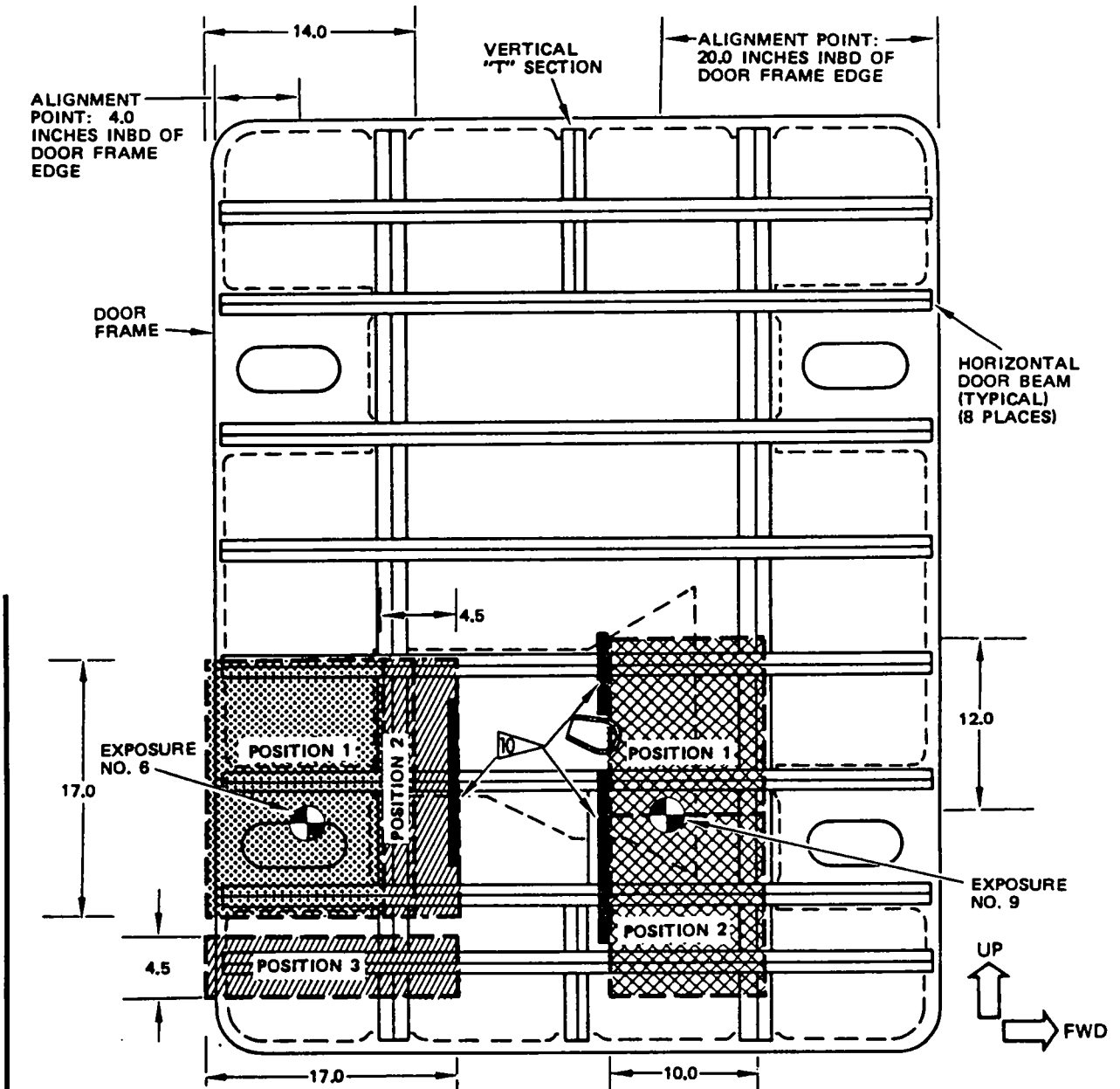

CENTER CARGO DOOR FILM  
 POSITIONS AND ALIGNMENT POINTS  
 DETAIL V (CONT)

Cargo Door Beams  
 Figure 3 (Sheet 17)

**BOEING**   
**COMMERCIAL JET**  
**NONDESTRUCTIVE TEST**



**NOTES**

- ALL DIMENSIONS ARE IN INCHES
- SEE DETAIL I  FOR A/P EFFECTIVITY
- SEE TABLE III FOR X-RAY PARAMETERS
-  X-RAY GENERATOR
-  4.5 X 17 FILM COVERAGE
-  14 X 17 FILM COVERAGE
-  10 X 12 FILM COVERAGE
-  EXTERNAL FAIRING SUPPORT

PLAN VIEW - LOOKING IN  
BASIC INTERNAL STRUCTURE

CENTER CARGO DOOR FILM  
POSITIONS AND ALIGNMENT POINTS  
DETAIL V (CONT)

Cargo Door Beams  
Figure 3 (Sheet 18)

**BOEING**  
**COMMERCIAL JET**  
**NONDESTRUCTIVE TEST**

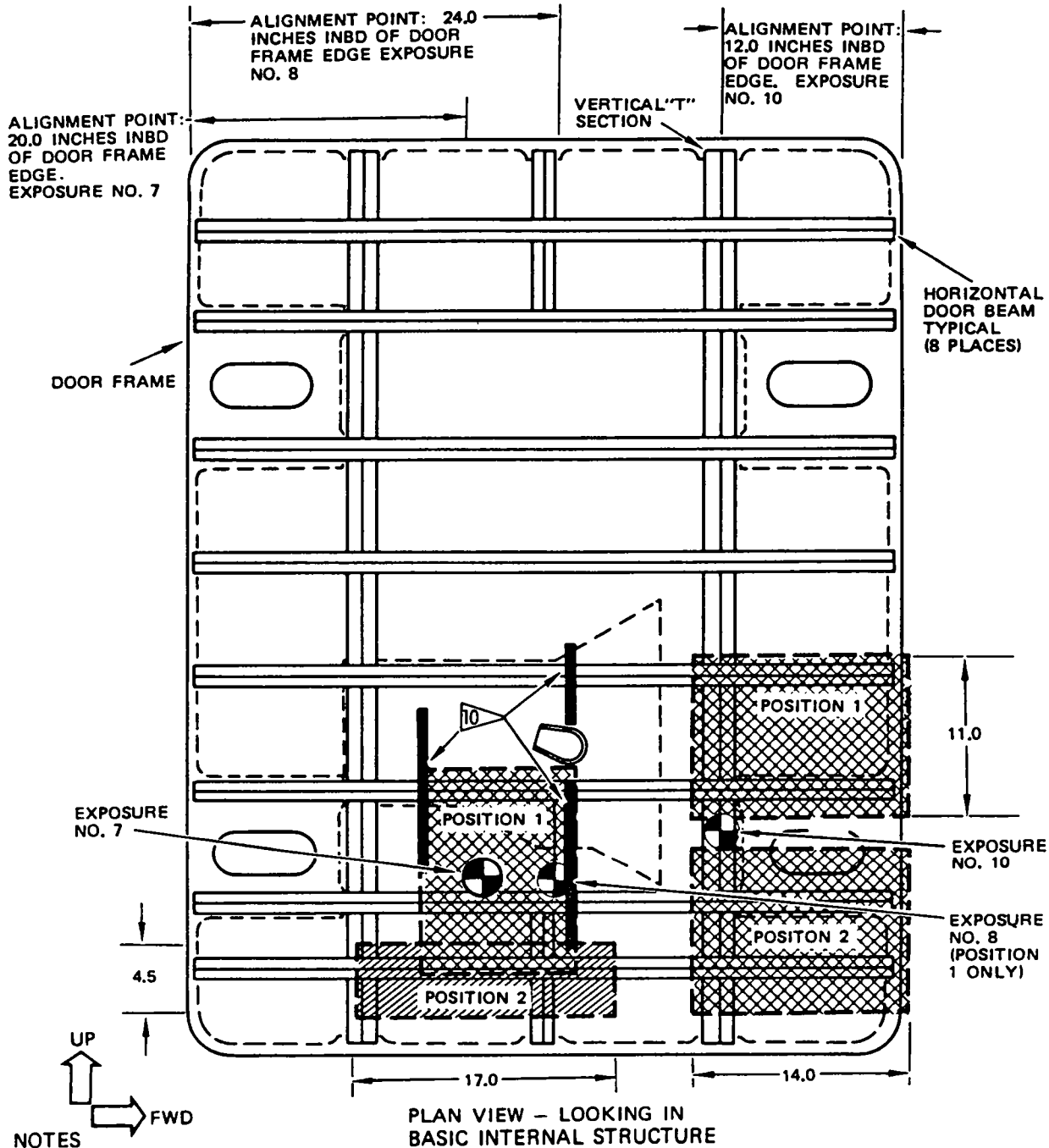

**NOTES**

● ALL DIMENSIONS ARE IN INCHES

● SEE DETAIL 19 FOR A/P EFFECTIVITY

● SEE TABLE III FOR X-RAY PARAMETERS

⊙ X-RAY GENERATOR

⊗ 11 X 14 FILM COVERAGE

▨ 4 1/2 X 17 FILM COVERAGE

▷ EXTERNAL FAIRING SUPPORT

CENTER CARGO DOOR FILM  
 POSITIONS AND ALIGNMENT POINTS  
 DETAIL V (CONT)

Cargo Door Beams  
 Figure 3 (Sheet 19)

**BOEING**   
**COMMERCIAL JET**  
**NONDESTRUCTIVE TEST**

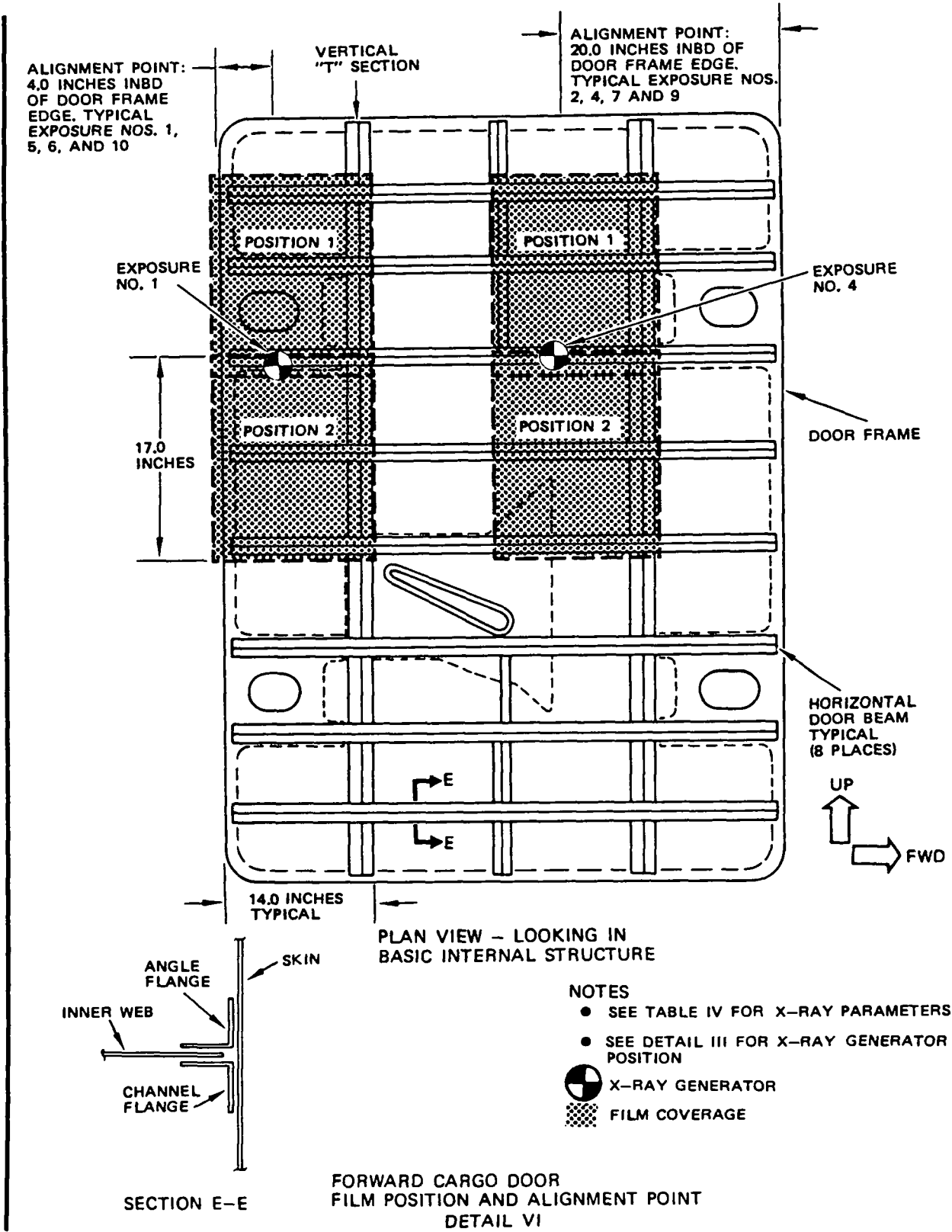

Cargo Door Beams  
 Figure 3 (Sheet 20)

**BOEING**   
**COMMERCIAL JET**  
**NONDESTRUCTIVE TEST**

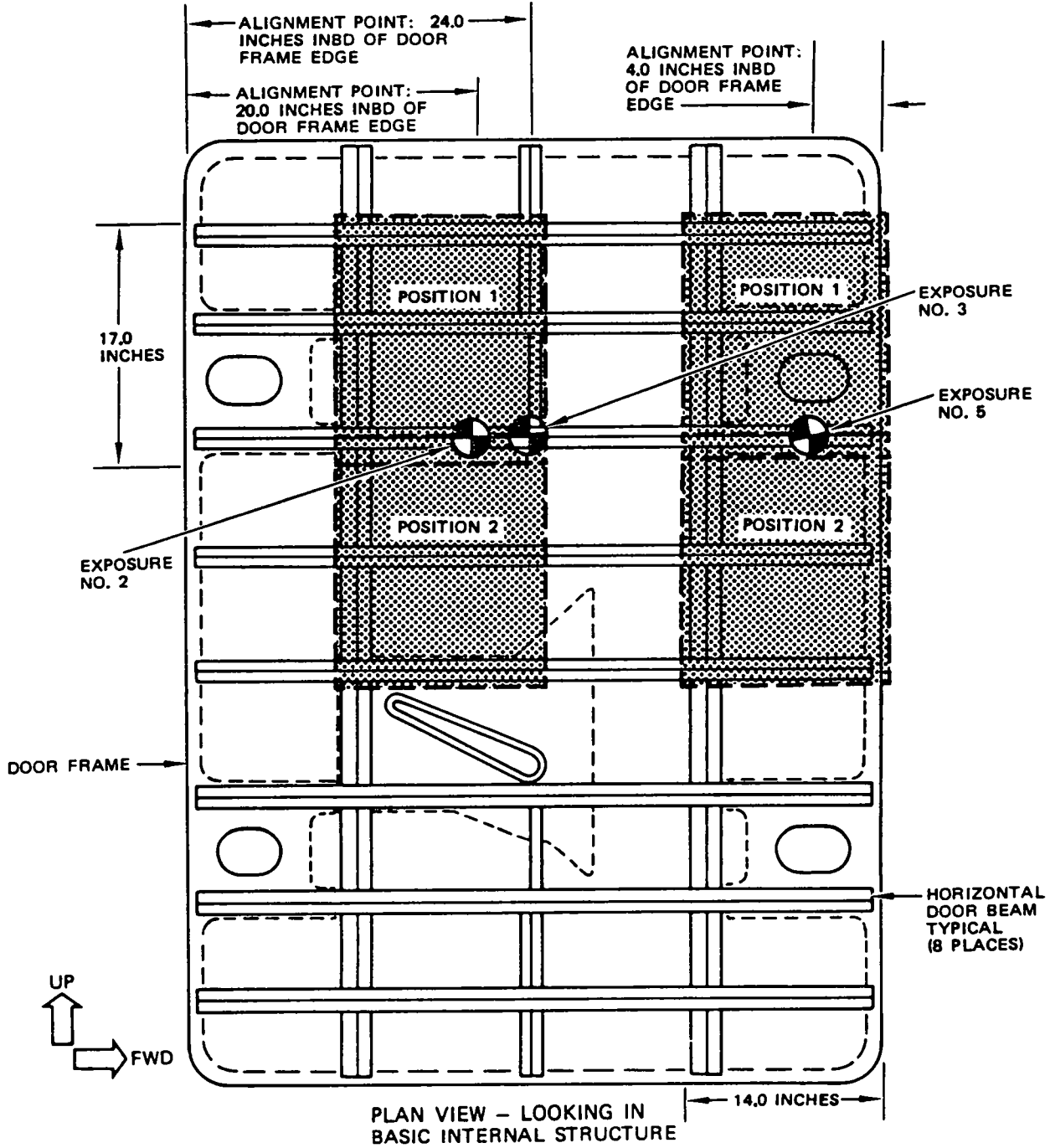

**NOTES**

- SEE TABLE IV FOR X-RAY PARAMETERS
- SEE DETAIL III FOR X-RAY GENERATOR POSITIONING

 X-RAY GENERATOR

 FILM COVERAGE

FORWARD CARGO DOOR FILM  
 POSITION AND ALIGNMENT POINT  
 DETAIL VI (CONT)

Cargo Door Beams  
 Figure 3 (Sheet 21)

**BOEING**   
**COMMERCIAL JET**  
**NONDESTRUCTIVE TEST**

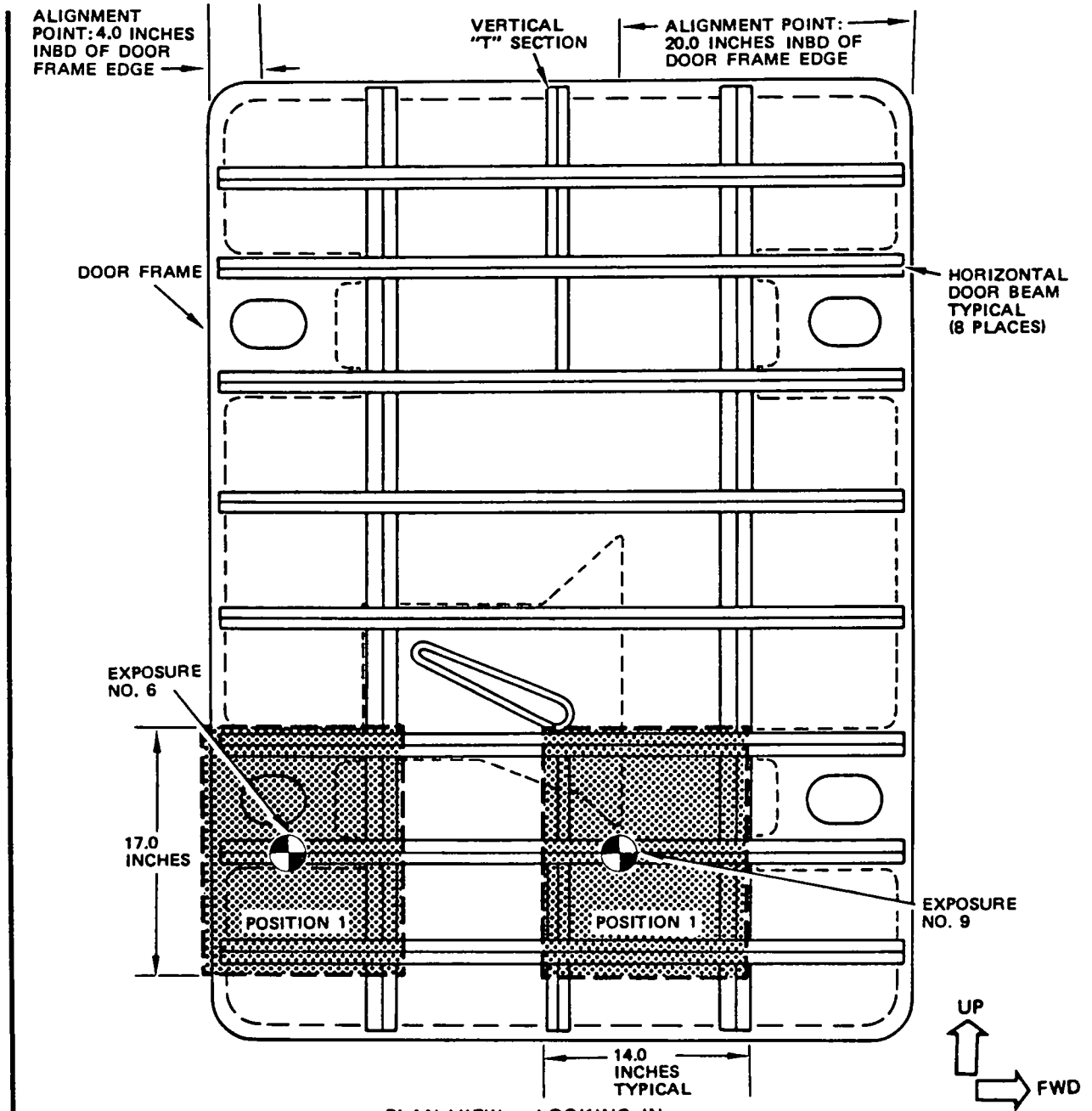

PLAN VIEW - LOOKING IN  
 BASIC INTERNAL STRUCTURE

**NOTES**

- SEE DETAIL III FOR X-RAY GENERATOR POSITIONING
- SEE TABLE IV FOR X-RAY PARAMETERS

-  X-RAY GENERATOR
-  FILM COVERAGE

FORWARD CARGO DOOR FILM  
 POSITION AND ALIGNMENT POINT  
 DETAIL VI (CONT)

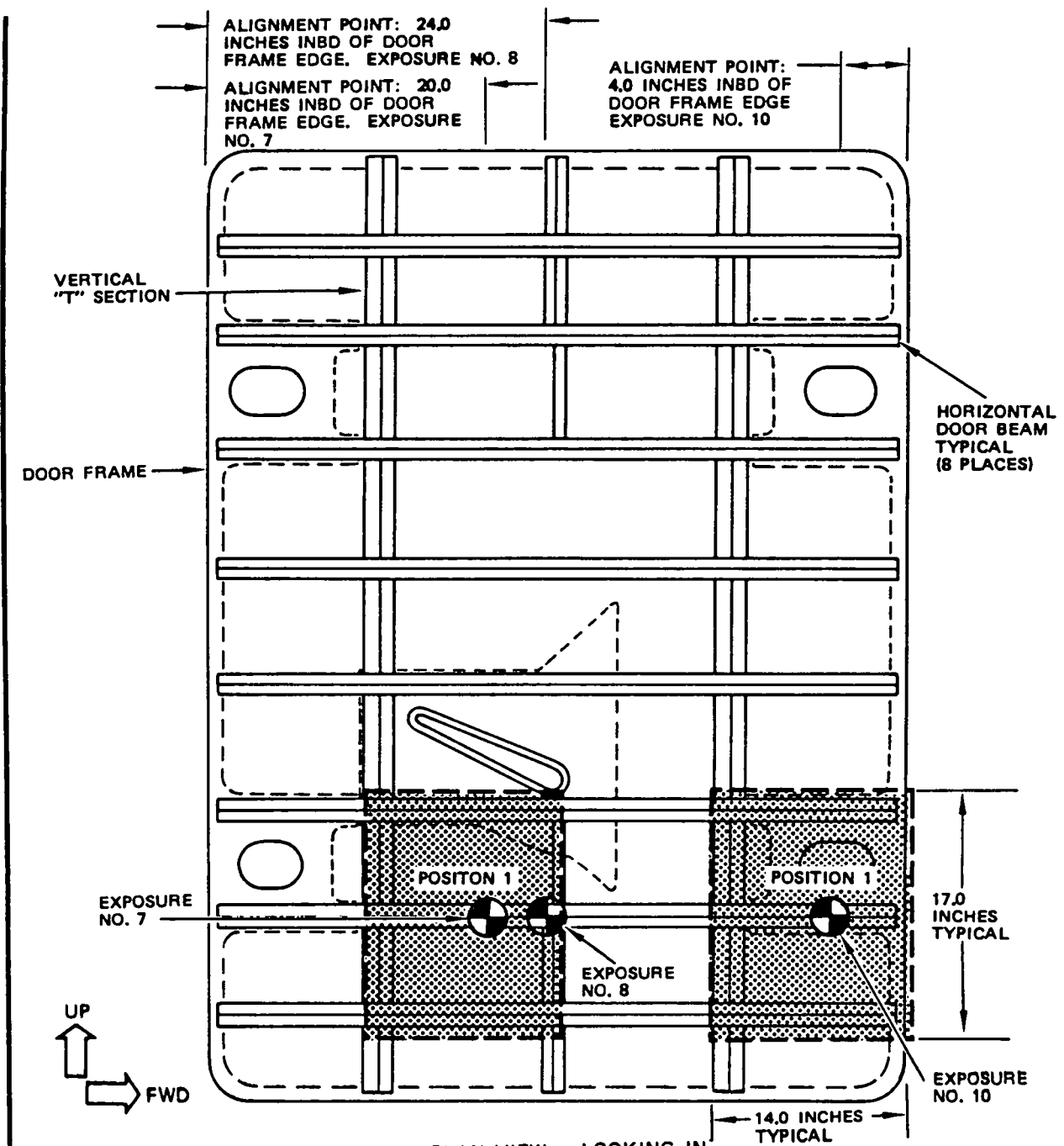

Cargo Door Beams  
 Figure 3 (Sheet 22)

**BOEING**   
**COMMERCIAL JET**  
**NONDESTRUCTIVE TEST**



PLAN VIEW - LOOKING IN  
 BASIC INTERNAL STRUCTURE

**NOTES**

- SEE DETAIL III FOR X-RAY GENERATOR POSITIONING
- SEE TABLE IV FOR X-RAY PARAMETERS
-  X-RAY GENERATOR
-  FILM COVERAGE

FORWARD CARGO DOOR FILM  
 POSITION AND ALIGNMENT POINT  
 DETAIL VI

Cargo Door Beams  
 Figure 3 (Sheet 23)