



sabena B707	Module: LWR FUS / EMPENA	A/C Reg :	Check :	 21F1000500
	Oper. : RT-MP LC			
	Type : REI-INSP	Issuer : A59513	Cert.St.: 45379	Page 1 of 2
Spec. : ELECTRICIAN	Release Date: 11.09.2008			

MAIN BATTERY CHECK

Execution / Start Date:	
End Date:	

MAINT	RII/INSP

sabena B707	Module: LWR FUS / EMPENA	A/C Reg :	Check :	 21F1000500 Page 2 of 2
	Oper. : RT-MP LC			
	Type : REI-INSP	Issuer : A59513	Cert.St.: 45379	
	Spec. : ELECTRICIAN	Release Date: 11.09.2008		

MAIN BATTERY CHECK

					MAINT	RII/INSP
Nr.	Hardtime	Task	Spec.	Related Documents		
1.		E3 S	REI	MMS-328 243001 00200 rev 16/03/06		
Check: A						
Zones: 131						
Access:						
NRC YES <input type="radio"/> NO <input type="radio"/>		IF YES, NUMBER(S):				

MAIN BATTERY:

PERFORM MAIN BATTERY WATER LEVEL CHECK (LEAD ACID)

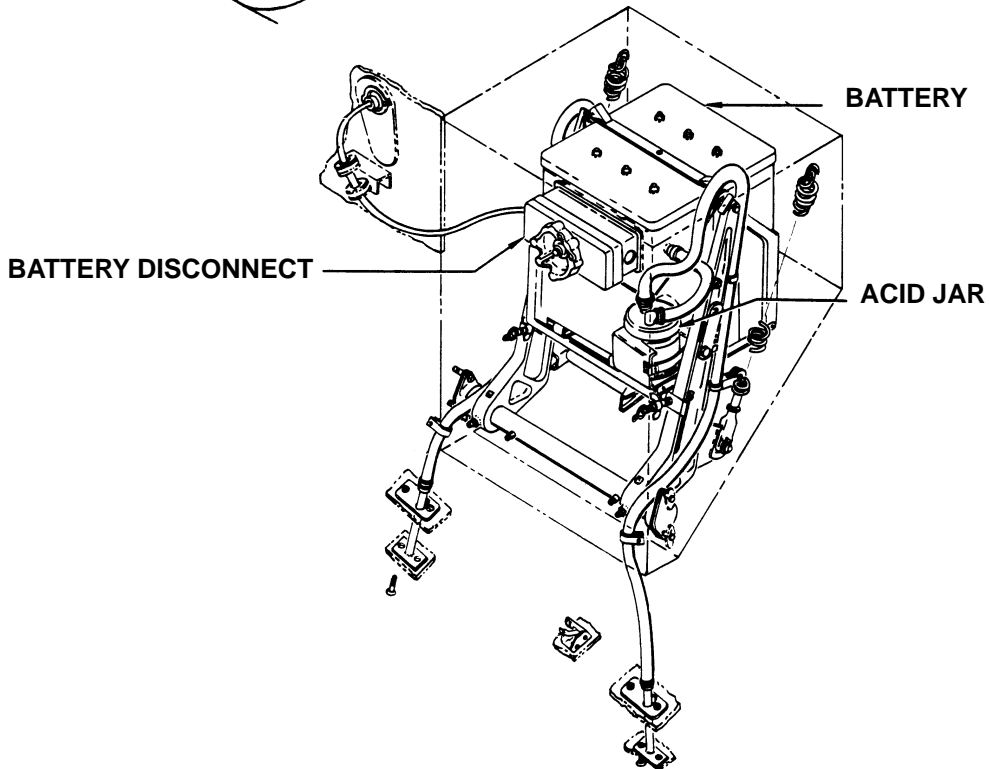
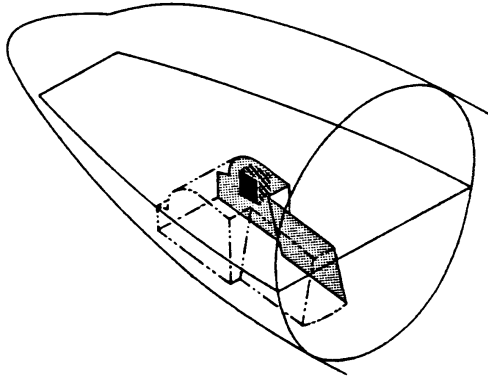

MAIN BATTERY CHECK