



sabena [®] B707	Module: LWR FUS / EMPENA	A/C Reg :	Check :	 21H1000500
	Oper. : RT-MP LC			
	Type : SERVICING	Issuer : A43710	Cert.St.: 24828	
Spec. : MECHANIC	Release Date: 10.10.2001		Page 1 of 2	

AIR CYCLE MACH. OIL LEVEL CHECK

Execution / Start Date:	
End Date:	

MAINT	RII/INSP

sabena B707	Module: LWR FUS / EMPENA	A/C Reg :	Check :	 21H1000500 Page 2 of 2
	Oper. : RT-MP LC	Issuer : A43710	Cert.St.: 24828	
	Type : SERVICING	Release Date: 10.10.2001		
	Spec. : MECHANIC			

AIR CYCLE MACH. OIL LEVEL CHECK

					MAINT	RII/INSP
Nr.	Hardtime	Task	Spec.	Related Documents		
1.		S	MEC	MMS-328 215001 00100 rev 15/05/01		
Check: A						
Zones: 133, 134						
Access: 1124 L, 1124 R						

AIR CYCLE MACHINE

1. CHECK: AIR CYCLE MACHINE OIL LEVEL ON LH & RH SIDE.

LH.SIDE.

RH.SIDE.

NOTE: IF NECESSARY SERVICE AIR CYCLE MACHINE WITH OIL MIL-L-6085 TO FULL MARK ON DRIPSTICK.

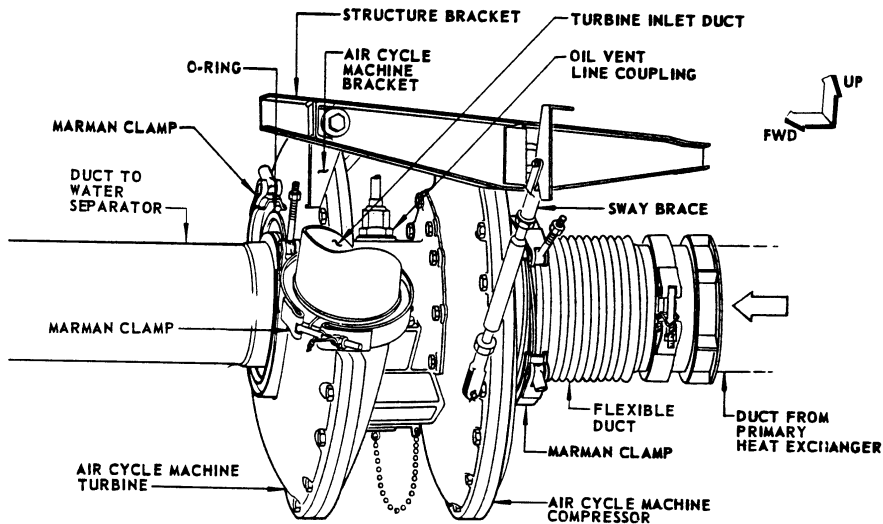
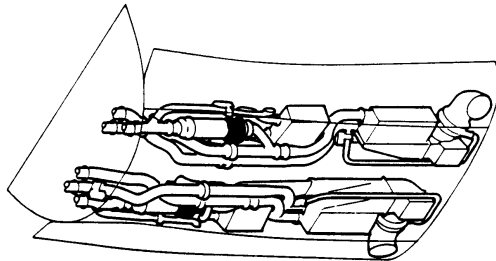

AIR CYCLE MACH. OIL LEVEL CHECK