

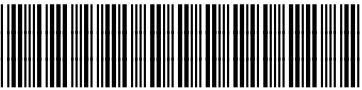

sabena [®] B707	Module: LH WING + FL CTR	A/C Reg :	Check :	
	Oper. : RT-MP LC			
	Type : * ZONAL INSP*	Issuer : A59513	Cert.St.: 45379	31E0000503
Spec. : MECHANIC	Release Date: 11.09.2008		Page 1 of 3	

AD 04-22-24 rev . LH WING R/S CHORD INSP (1/4)

		MAINT	RII/INSP
Execution / Start Date:			
End Date:			

AD 04-22-24 rev . LH WING R/S CHORD INSP (1/4)

sabena B707	Module: LH WING + FL CTR	A/C Reg :	Check :	 31E0000503 Page 2 of 3
	Oper. : RT-MP LC	Issuer : A59513	Cert.St.: 45379	
	Type : * ZONAL INSP*	Release Date: 11.09.2008		
Spec. : MECHANIC				

AD 04-22-24 rev . LH WING R/S CHORD INSP (1/4)

					MAINT	RII/INSP									
Nr.	Hardtime	Task	Spec.	Related Documents											
1.		E3 S	MEC	AD 01-08-02 rev . AD 04-22-24 rev . AD 92-03-12 rev . MMS-328 575040 01001 rev 09.08.06 SB 57-3240 rev 4											
Check: C															
Zones: 500															
Access:															
NRC YES <input type="radio"/> NO <input type="radio"/> IF YES, NUMBER(S):															
<p>CONDITIONS: – Trailing edge flaps full extended position & spoilers to full-up position. – Upper & lower chord externally exposed surfaces from wing-to-body joint to the wing tip = CLEAN.</p> <p>LH WING REAR SPAR CHORDS INSPECTION.</p> <p>NOTE: Added annex for removal/installation parts on pt 1.</p> <p>1. Remove acces panels, covers, doors & any other removal components to get acces to the entire length of the rear spar chords.</p> <p>2. Detailed visual inspection of the entire length of the external surfaces for corrosion & cracks, with special attention around the heads of fasteners, around the edges of fittings, brackets & stiffeners attached to the chord, & in the radius between the vertical & horizontal flange of chord.</p> <p>3. If paint discoloration, blistering, raised or rough spots in the paint finish are found, scrape off the paint to determine extend of damage. Check suspect crack indications with a mirror, magnifying lenses etc...</p> <p>If cracks: Report to engineering as crack, do not drill cracks or install repair given in rev 3 of SB 3240.</p> <p>4. If no corrosion or cracks are found apply AV 30 to the exposed surfaces of the upper & lower chords on rear spar.</p> <table border="1" data-bbox="263 1668 949 1848"> <thead> <tr> <th colspan="3">FINDINGS</th> </tr> </thead> <tbody> <tr> <td>OK</td> <td>CT:</td> <td></td> </tr> <tr> <td>NOT OK</td> <td>CT:</td> <td>DR.nr:</td> </tr> </tbody> </table> <p>5. Install acces panels, covers, doors & any other components removed at pt 1, (see annex).</p>					FINDINGS			OK	CT:		NOT OK	CT:	DR.nr:		
FINDINGS															
OK	CT:														
NOT OK	CT:	DR.nr:													

AD 04-22-24 rev . LH WING R/S CHORD INSP (1/4)

sabena B707	Module: LH WING + FL CTR	A/C Reg :	Check :	
	Oper. : RT-MP LC			
	Type : * ZONAL INSP*	Issuer : A59513	Cert.St.: 45379	31E0000503
	Spec. : MECHANIC	Release Date: 11.09.2008		Page 3 of 3

AD 04-22-24 rev . LH WING R/S CHORD INSP (1/4)

MAINT RII/INSP

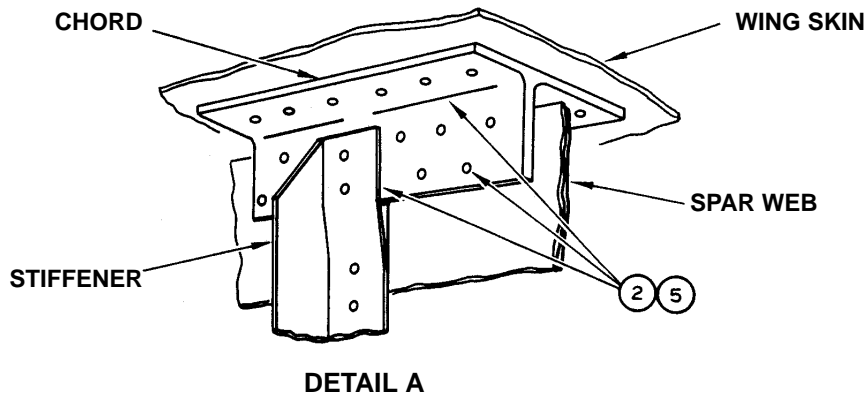
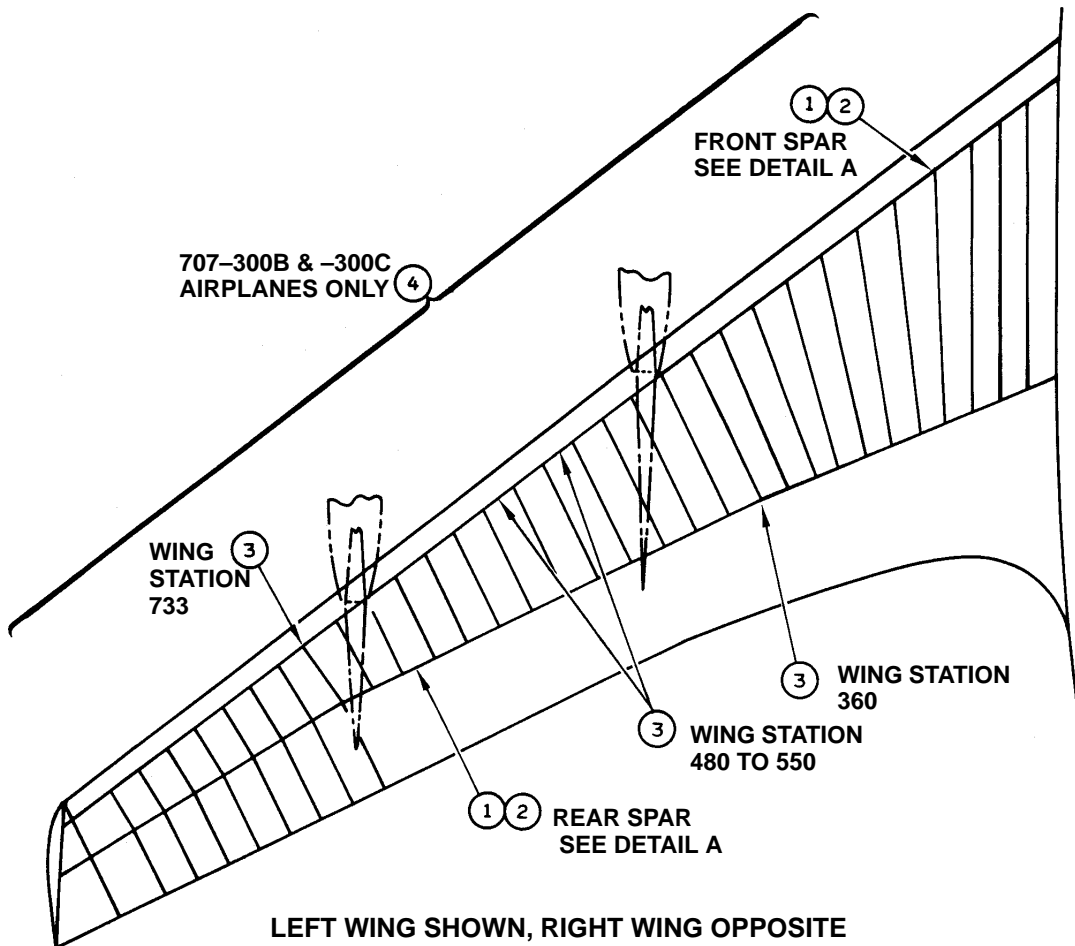

FIGURE 1. SPAR CHORD INSPECTION