



sabena [®] B707	Module: LH WING + FL CTR	A/C Reg :	Check :	 31F2000519
	Oper. : RT-MP LC			
	Type : MEC-INSP	Issuer : A43710	Cert.St.: 24828	
Spec. : MECHANIC	Release Date: 11.10.2001		Page 1 of 4	

LH WING INB & OUTB SPOIL CTRL VLV FILTER INSP

Execution / Start Date:	
End Date:	

MAINT	RII/INSP

sabena B707	Module: LH WING + FL CTR	A/C Reg :	Check :	
	Oper. : RT-MP LC			
	Type : MEC-INSP	Issuer : A43710	Cert.St.: 24828	31F2000519
Spec. : MECHANIC	Release Date: 11.10.2001		Page 2 of 4	

LH WING INB & OUTB SPOIL CTRL VLV FILTER INSP

					MAINT	RII/INSP
Nr.	Hardtime	Task	Spec.	Related Documents		
1.		E3	MEC	MM 27-4-21 rev REV MS MM 27-4-31 rev REV MS MMS-328 276004 00101 rev 05/02/01		
Check: C						
Zones: 582, 584						
Access: 1356L, 1358L						

INB & OUTB SPOILER CTRL VLV FILTER INSP.

1. Inspection of INB spoiler control valve.

1. Flaps to DOWN position.
2. Remove spoiler control valve cover (1, Figure 001).
3. Check control valve filter for foreign matter.
4. Install spoiler control valve cover.

2. Inspection of OUTB spoiler control valve.

1. Flaps to DOWN position.
2. Check control valve filter for foreign matter. (Figure 002.).

sabena B707	Module: LH WING + FL CTR	A/C Reg :	Check :	 31F2000519 Page 3 of 4
	Oper. : RT-MP LC	Issuer : A43710	Cert.St.: 24828	
	Type : MEC-INSP	Release Date: 11.10.2001		
Spec. : MECHANIC				

LH WING INB & OUTB SPOIL CTRL VLV FILTER INSP

MAINT RII/INSP

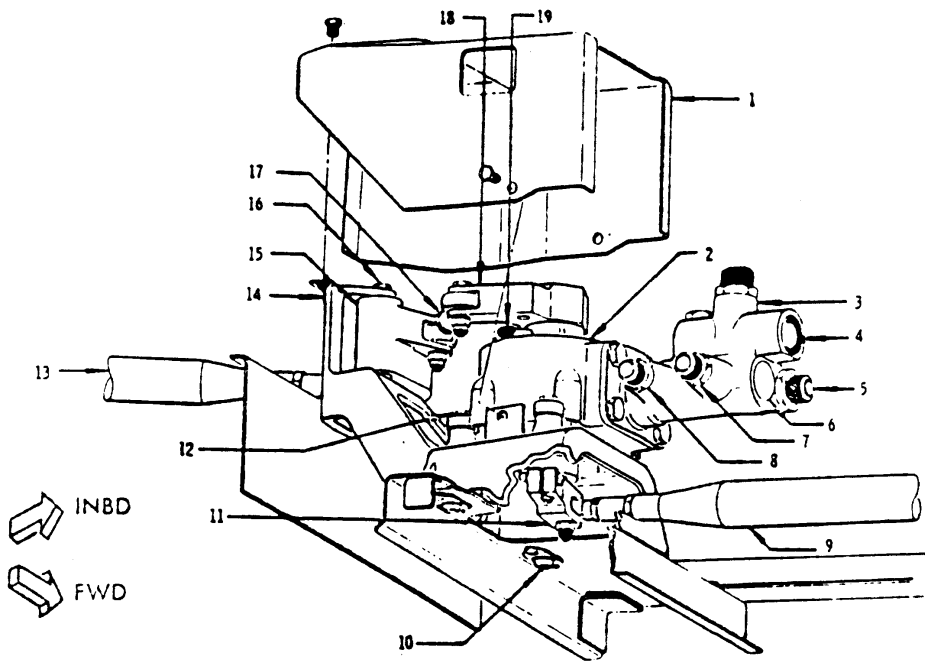
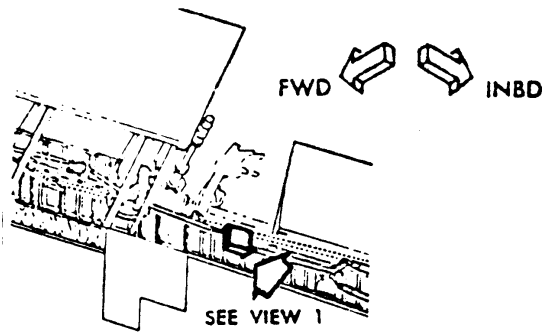

- | | | |
|---------------------------------|------------------------------------|---------------------------|
| 1 CONTROL VALVE COVER | 8 UP PORT | 15 PUSH ROD CONTROL CRANK |
| 2 CONTROL VALVE | 9 CONTROL VALVE FOLLOW-UP PUSH ROD | 16 CONTROL CRANK BOLT |
| 3 PRESSURE PORT | 10 VALVE ASSEMBLY MOUNTING BOLTS | 17 CRANK CONNECTING ROD |
| 4 FILTER PLUG | 11 FOLLOW-UP ARM | 18 VALVE CRANK |
| 5 RETURN PORT | 12 CONTROL VALVE MOUNTING BOLTS | 19 VENT PLUG |
| 6 CONTROL VALVE METERING PISTON | 13 CONTROL VALVE PUSH ROD | 20 COTTER PIN |
| 7 DOWN PORT | 14 VALVE SUPPORT | 21 VERNIER SLEEVE |

FIGURE 001.

sabena B707	Module: LH WING + FL CTR	A/C Reg :	Check :	 31F2000519
	Oper. : RT-MP LC	Issuer : A43710	Cert.St.: 24828	
	Type : MEC-INSP	Release Date: 11.10.2001	Page 4 of 4	
Spec. : MECHANIC				

LH WING INB & OUTB SPOIL CTRL VLV FILTER INSP

MAINT RII/INSP

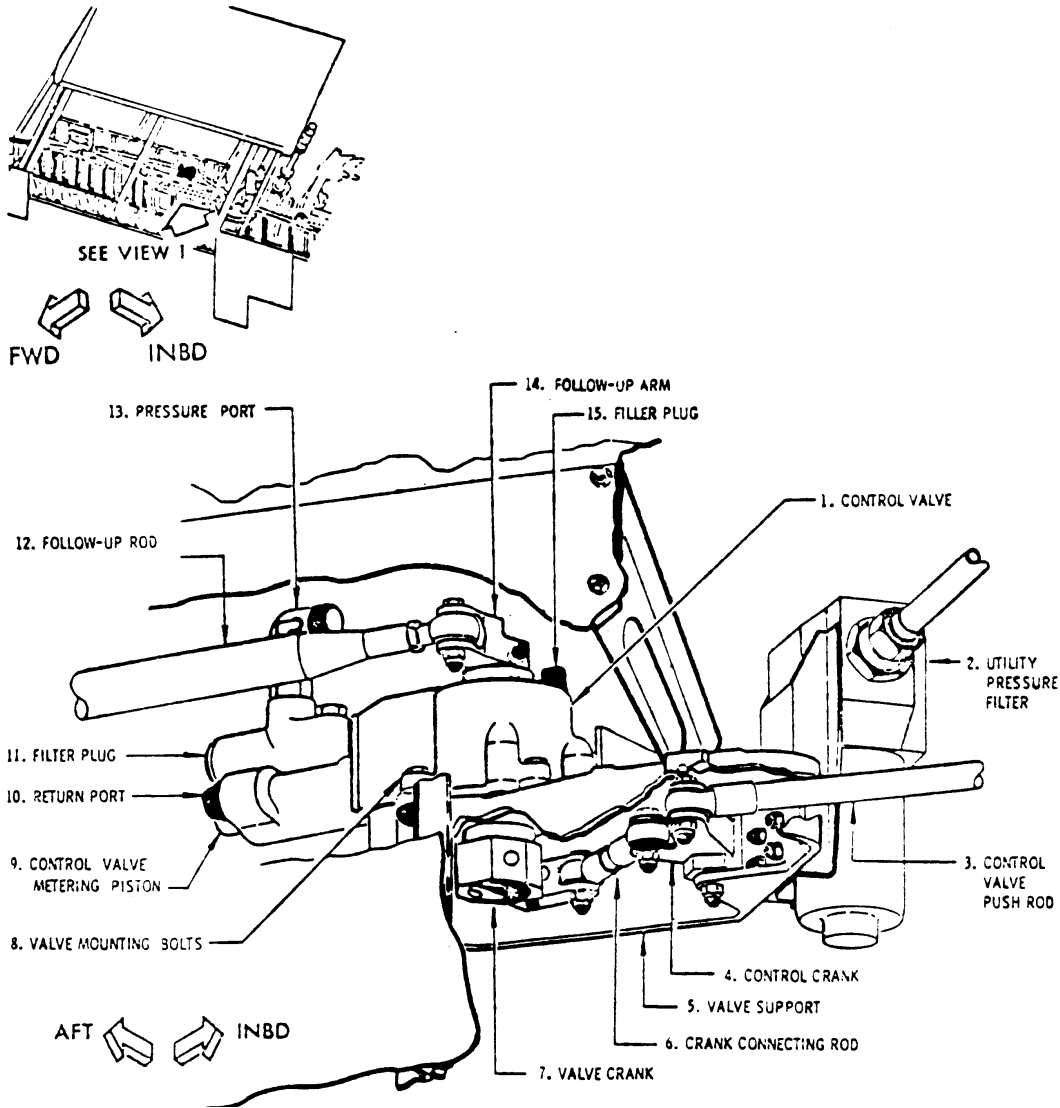

FIGURE 002.