

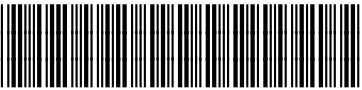

sabena [®] B707	Module: LH WING + FL CTR	A/C Reg :	Check :	 31F4000516
	Oper. : RT-MP LC			
	Type : NDT INSP	Issuer : A59513	Cert.St.: 46928	Page 1 of 7
Spec. : NDT INSP	Release Date: 24.11.2005			

LH WING LWR SURF HFEC INSP

Execution / Start Date:	
End Date:	

MAINT	RII/INSP

sabena B707	Module: LH WING + FL CTR	A/C Reg :	Check :	 31F4000516 Page 2 of 7
	Oper. : RT-MP LC	Issuer : A59513	Cert.St.: 46928	
	Type : NDT INSP	Release Date: 24.11.2005		
Spec. : NDT INSP				

LH WING LWR SURF HFEC INSP

					MAINT	RII/INSP
Nr.	Hardtime	Task	Spec.	Related Documents		
1.	16527 CYC	E4	NDT	AD 81-11-06 R1 rev 4178 MMS-328 570150 02003 rev 15.07.05 SB 57A3395 rev .		
Check: C1						
Zones: 571, 572						
Access: 1325L, 1326L, 1327L, 1328L						
NRC YES <input type="radio"/> NO <input type="radio"/>		IF YES, NUMBER(S):				

PREPARATION FOR INSPECTION:

1. Defuel & purge tank.
2. Remove sealant as required from the FWD & AFT side of all fasteners comon to the lower flanges of all stringers from F/S TO R/S, BETWEEN WBL 59.24 & 40 INCHES OUTBD.

HFEC INSPECTION OF WING LWR SURFACE WBL 59.24, F/S TO R/S.

DO A HFEC INTERNAL INSPECTION OF WING LOWER SURFACE ALL STRINGERS FROM F/S TO R/S, BETWEEN WBL 59.24 & 40 INCHES OUTBOARD: INSPECT FOR CRACKS IN FILLET RADII OF ALL STRINGERS WITH WEEP HOLES, AS SPECIFIED IN SB 3395 FIG 2 (Refer. Doc. ,D6-48023, PART 6, 57-10-07, FIG 75).

RESTORE AIRPLANE:

1. Reapply sealant removed.
2. Refuel tank.

Nr.	Hardtime	Task	Spec.	Related Documents		
2.	16636 CYC	E4	NDT	AD 81-11-06 R1 rev 4178 MMS-328 570150 02003 rev 15.07.05 SB 57A3395 rev .		
Check: C1						
Zones: 571, 572						
Access: 1325L, 1326L, 1327L, 1328L						
NRC YES <input type="radio"/> NO <input type="radio"/>		IF YES, NUMBER(S):				

LH WING LWR SURF HFEC INSP

sabena B707	Module: LH WING + FL CTR	A/C Reg :	Check :	 31F4000516 Page 3 of 7
	Oper. : RT-MP LC			
	Type : NDT INSP	Issuer : A59513	Cert.St.: 46928	
	Spec. : NDT INSP	Release Date: 24.11.2005		

LH WING LWR SURF HFEC INSP

MAINT RII/INSP

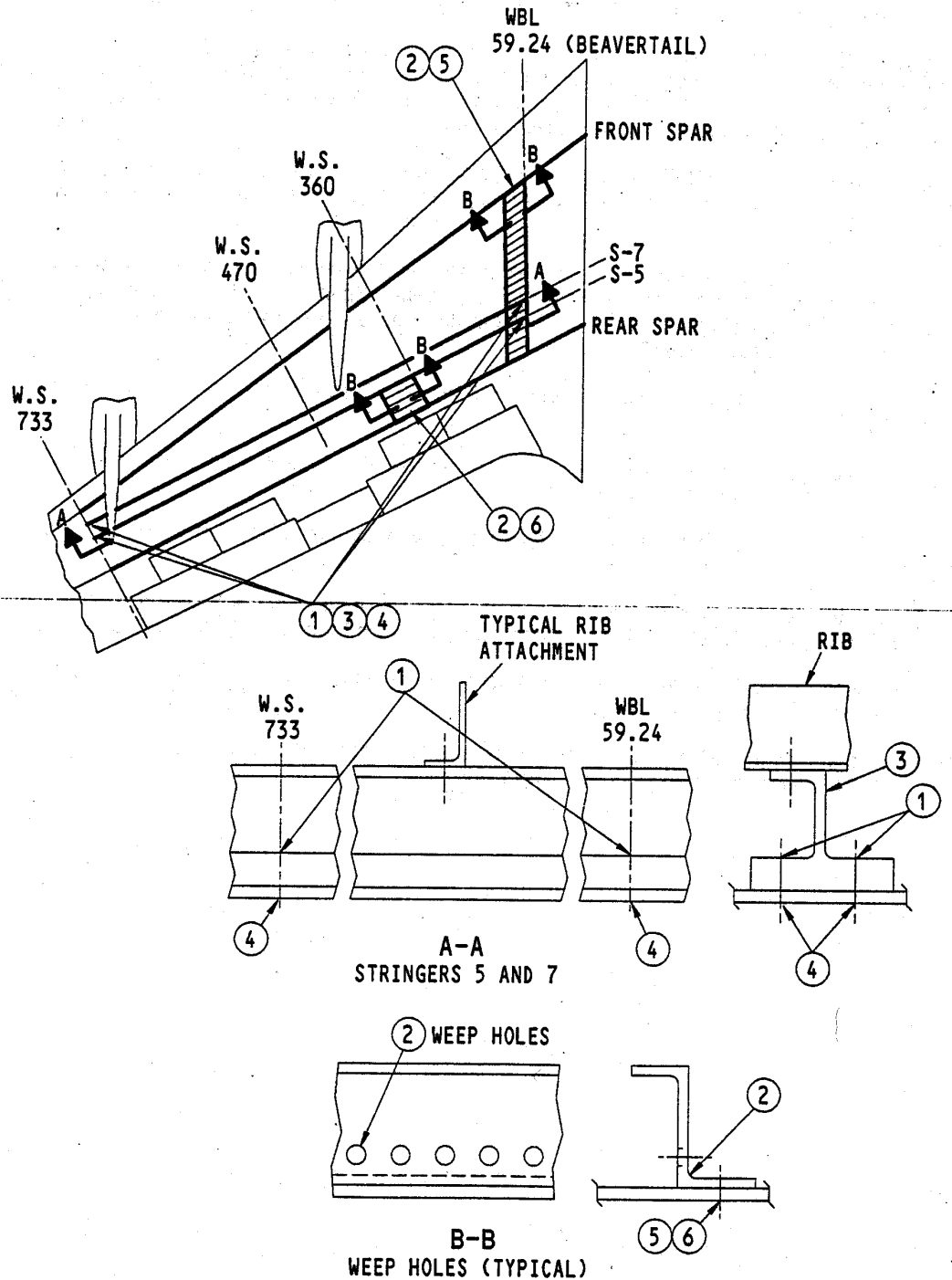
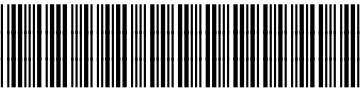

FIGURE 2. 707 SERIES INSPECTIONS OF WING LOWER SKIN AND STRINGERS

sabena B707	Module: LH WING + FL CTR	A/C Reg :	Check :	 31F4000516 Page 4 of 7
	Oper. : RT-MP LC	Issuer : A59513	Cert.St.: 46928	
	Type : NDT INSP	Release Date: 24.11.2005		
Spec. : NDT INSP				

LH WING LWR SURF HFEC INSP

PREPARATION FOR INSPECTION:

1. Defuel & purge tank.
2. Remove sealant as required from the FWD & AFT side of all fasteners comon to the lower flanges of all stringers from F/S TO R/S, BETWEEN WBL 59.24 & 40 INCHES OUTBD.

HFEC INSPECTION OF WING LWR SURFACE WBL 59.24, F/S TO R/S.

DO A HFEC INTERNAL INSPECTION OF WING LOWER SURFACE ALL STRINGERS FROM F/S TO R/S, BETWEEN WBL 59.24 & 40 INCHES OUTBOARD: INSPECT FOR CRACKS IN FILLET RADII OF ALL STRINGERS WITH WEEP HOLES, AS SPECIFIED IN SB 3395 FIG 2 (Refer. Doc. ,D6-48023, PART 6, 57-10-07, FIG 75).

RESTORE AIRPLANE:

1. Reapply sealant removed.
2. Refuel tank.

MAINT **RII/INSP**

Nr.	Hardtime	Task	Spec.	Related Documents
3.		E4	NDT	AD 81-11-06 R1 rev 4178 MMS-328 570150 02003 rev 15.07.05 SB 57A3395 rev .
Check: C1				
Zones: 571, 572				
Access: 1325L, 1326L, 1327L, 1328L				
NRC YES <input type="radio"/> NO <input type="radio"/>		IF YES, NUMBER(S):		

PREPARATION FOR INSPECTION:

1. Defuel & purge tank.
2. Remove sealant as required from the FWD & AFT side of all fasteners comon to the lower flanges of all stringers from F/S TO R/S, BETWEEN WBL 59.24 & 40 INCHES OUTBD.

HFEC INSPECTION OF WING LWR SURFACE WBL 59.24, F/S TO R/S.

LH WING LWR SURF HFEC INSP

sabena B707	Module: LH WING + FL CTR	A/C Reg :	Check :	 31F4000516 Page 5 of 7
	Oper. : RT-MP LC			
	Type : NDT INSP	Issuer : A59513	Cert.St.: 46928	
	Spec. : NDT INSP	Release Date: 24.11.2005		

LH WING LWR SURF HFEC INSP

MAINT RII/INSP

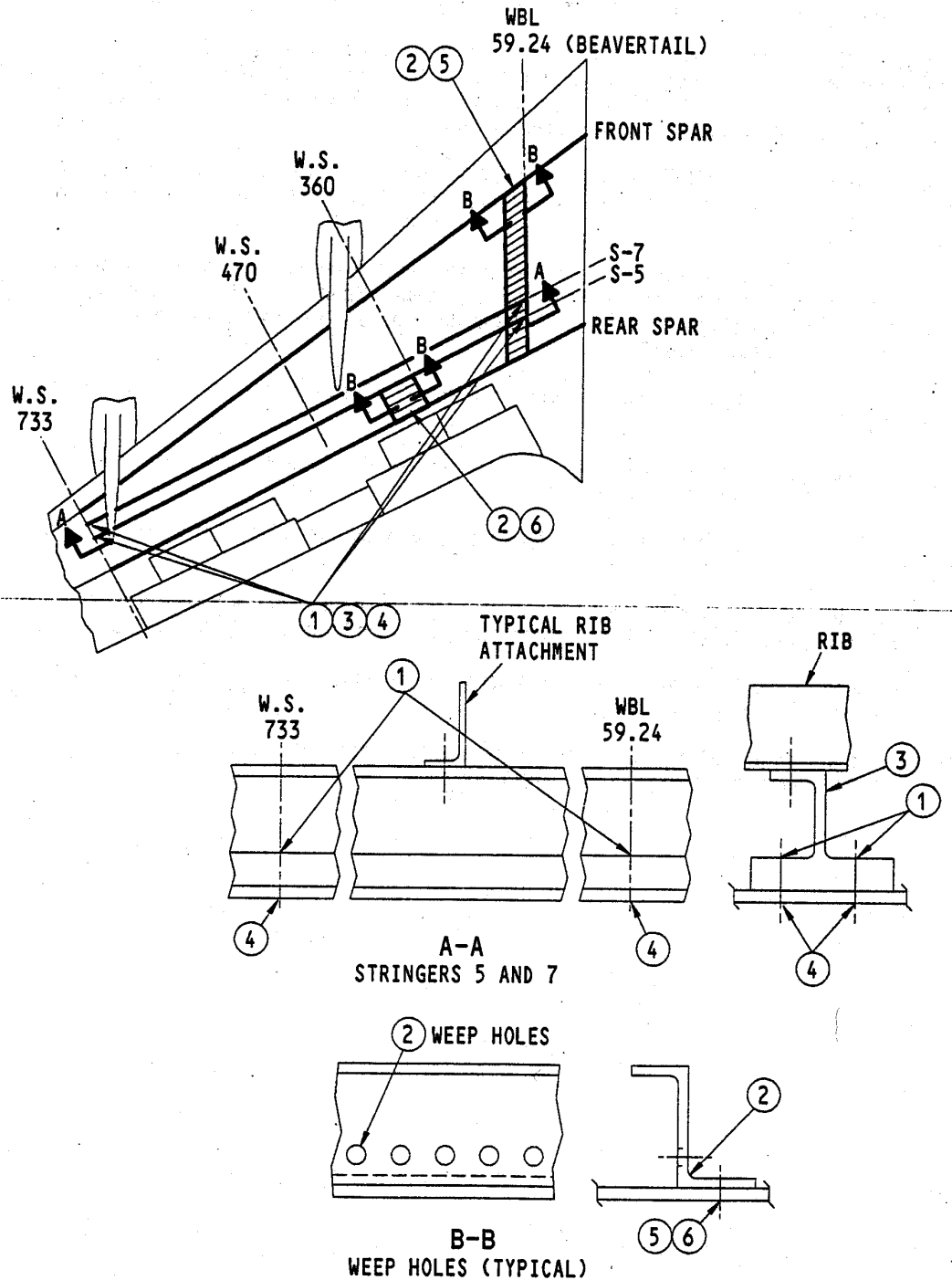



FIGURE 2. 707 SERIES INSPECTIONS OF WING LOWER SKIN AND STRINGERS

sabena B707	Module: LH WING + FL CTR	A/C Reg :	Check :	 31F4000516 Page 7 of 7
	Oper. : RT-MP LC			
	Type : NDT INSP	Issuer : A59513	Cert.St.: 46928	
	Spec. : NDT INSP	Release Date: 24.11.2005		

LH WING LWR SURF HFEC INSP

MAINT RII/INSP

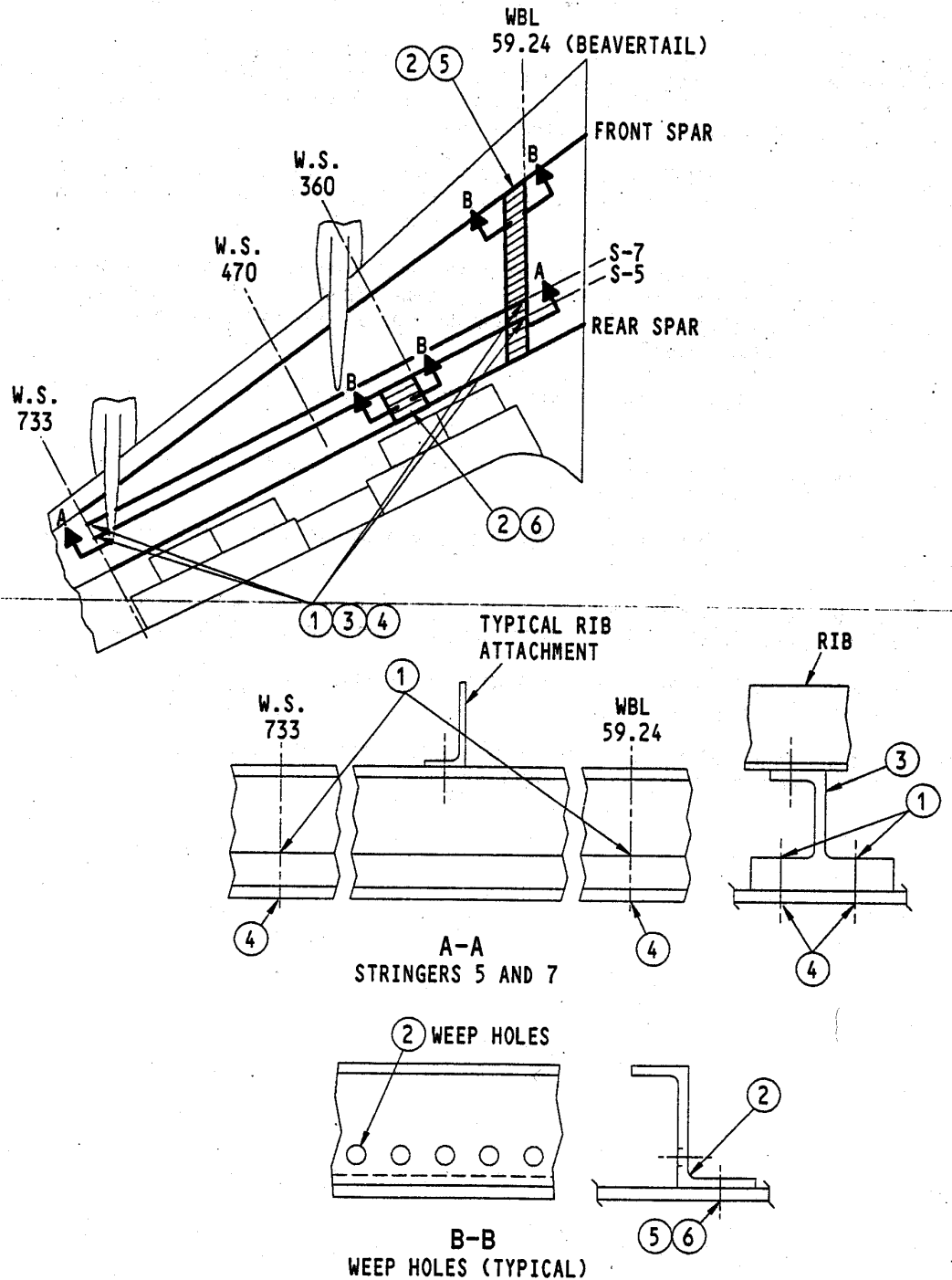

FIGURE 2. 707 SERIES INSPECTIONS OF WING LOWER SKIN AND STRINGERS