

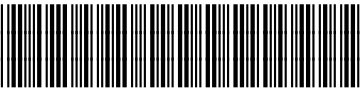

sabena [®] B707	Module: LH WING + FL CTR	A/C Reg :	Check :	 31F4000518
	Oper. : RT-MP LC			
	Type : NDT INSP	Issuer : A59513	Cert.St.: 45379	Page 1 of 3
Spec. : NDT INSP	Release Date: 11.09.2008			

AD 04-22-24 rev . LH WING R/S CHORD HFEC INSP (2/4)

		MAINT	RII/INSP
Execution / Start Date:			
End Date:			

sabena B707	Module: LH WING + FL CTR	A/C Reg :	Check :	 31F4000518 Page 2 of 3
	Oper. : RT-MP LC	Issuer : A59513	Cert.St.: 45379	
	Type : NDT INSP	Release Date: 11.09.2008		
Spec. : NDT INSP				

AD 04-22-24 rev . LH WING R/S CHORD HFEC INSP (2/4)

					MAINT	RII/INSP									
Nr.	Hardtime	Task	Spec.	Related Documents											
1.		E4 S	MEC	AD 01-08-02 rev . AD 04-22-24 rev . AD 92-03-12 rev . MMS-328 575040 01001 rev 09.08.06 SB 57-3240 rev 4											
Check: C															
Zones: 500															
Access:															
NRC YES <input type="radio"/> NO <input type="radio"/> IF YES, NUMBER(S):															
<p>CONDITIONS: – L.E flaps, slats & trailing edge flaps full extended position & spoilers to full-up position.</p> <p>– Upper & lower chord externally exposed surfaces from wing-to-body joint to the wing tip = CLEAN.</p> <p>LH WING REAR SPAR CHORDS INSPECTION.</p> <p>NOTE: Added annex for removal/installation parts on pt 1.</p> <p>1 Remove acces panels, covers, doors & any other removal components to get acces to the entire length of the rear spar chords.</p> <p>2. Perform inspection HFEC of the entire length of the chords for corrosion & cracks, with special attention around the heads of fasteners, around the edges of fittings, brackets & stiffeners attached to the chord, & in the radius between the vertical & horizontal flange of chord.</p> <p>3. If paint discoloration, blistering, raised or rough spots in the paint finish are found, scrape off the paint to determine extend of damage. Check suspect crack indications with a mirror, magnifying lenses etc...</p> <p>If cracks: Report to engineering as crack, do not drill cracks or install repair given in rev 3 of SB 3240.</p> <p>4. If no corrosion or cracks are found apply AV 30 to the exposed surfaces of the upper & lower chords on rear spar.</p>															
<table border="1" style="margin-left: auto; margin-right: auto;"> <thead> <tr> <th colspan="3">FINDINGS</th> </tr> </thead> <tbody> <tr> <td>OK</td> <td>CT:</td> <td></td> </tr> <tr> <td>NOT OK</td> <td>CT:</td> <td>DR.nr:</td> </tr> </tbody> </table>					FINDINGS			OK	CT:		NOT OK	CT:	DR.nr:		
FINDINGS															
OK	CT:														
NOT OK	CT:	DR.nr:													
5. Install acces panels, covers, doors & any other components removed at pt 1, (see annex).															

AD 04-22-24 rev . LH WING R/S CHORD HFEC INSP (2/4)

sabena B707	Module: LH WING + FL CTR	A/C Reg :	Check :	 31F4000518 Page 3 of 3
	Oper. : RT-MP LC	Issuer : A59513	Cert.St.: 45379	
	Type : NDT INSP	Release Date: 11.09.2008		
Spec. : NDT INSP				

AD 04-22-24 rev . LH WING R/S CHORD HFEC INSP (2/4)

MAINT RII/INSP

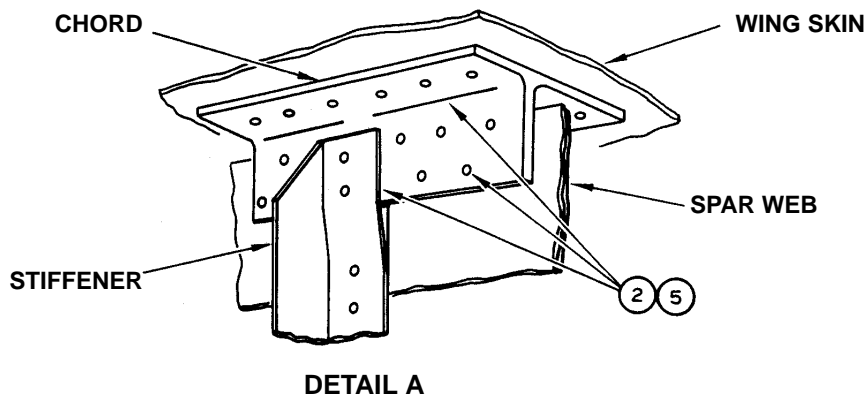
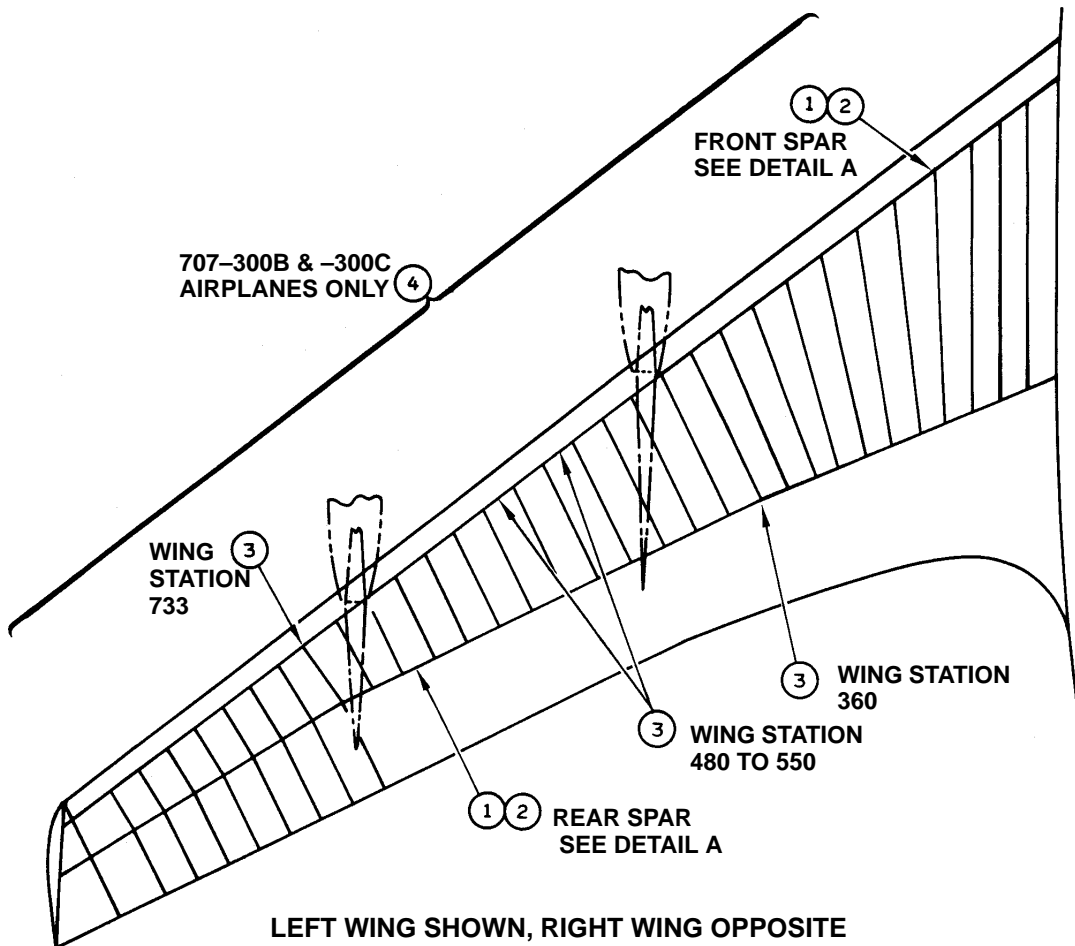

FIGURE 1. SPAR CHORD INSPECTION