



sabena [®] B707	Module: LH WING + FL CTR	A/C Reg :	Check :	 31F4000526
	Oper. : RT-MP LC			
	Type : NDT INSP	Issuer : A59513	Cert.St.: 46928	Page 1 of 7
Spec. : NDT INSP	Release Date: 22.11.2006			

LH WING REAR SPAR LOWER CHORD NDI INSPECTION

Execution / Start Date:	
End Date:	

MAINT	RII/INSP

sabena B707	Module: LH WING + FL CTR	A/C Reg :	Check :	 31F4000526 Page 2 of 7
	Oper. : RT-MP LC	Issuer : A59513	Cert.St.: 46928	
	Type : NDT INSP	Release Date: 22.11.2006		
	Spec. : NDT INSP			

LH WING REAR SPAR LOWER CHORD NDI INSPECTION

					MAINT	RII/INSP
Nr.	Hardtime	Task	Spec.	Related Documents		
1.	22083 CYC	E4	NDT	AD 85-12-01 R1 rev 5439 MMS-328 572080 02004 rev 15.07.05 SSID 57-A45-05/C3 rev P		
Check: C1						
Zones: 135, 572, 584						
Access: 1324 L						
NRC YES <input type="radio"/> NO <input type="radio"/>		IF YES, NUMBER(S):				

LH WING REAR SPAR LOWER CHORD

LH WING REAR SPAR LOWER CHORD, WEB TERMINAL FITTING / SPAR CHORD & WING LOWER SKIN BBL 70.50 TO WBL 59.24.

Do an H.F.E.C. or X-RAY internal inspection (as required) terminal fitting horizontal surfaces (including splice members).

Refer. X-RAY, DOC D6-48023, Part 2, 57-10-07, Fig 21

Refer. HFEC, DOC D6-48023, Part 2, 57-10-07, Fig 53.

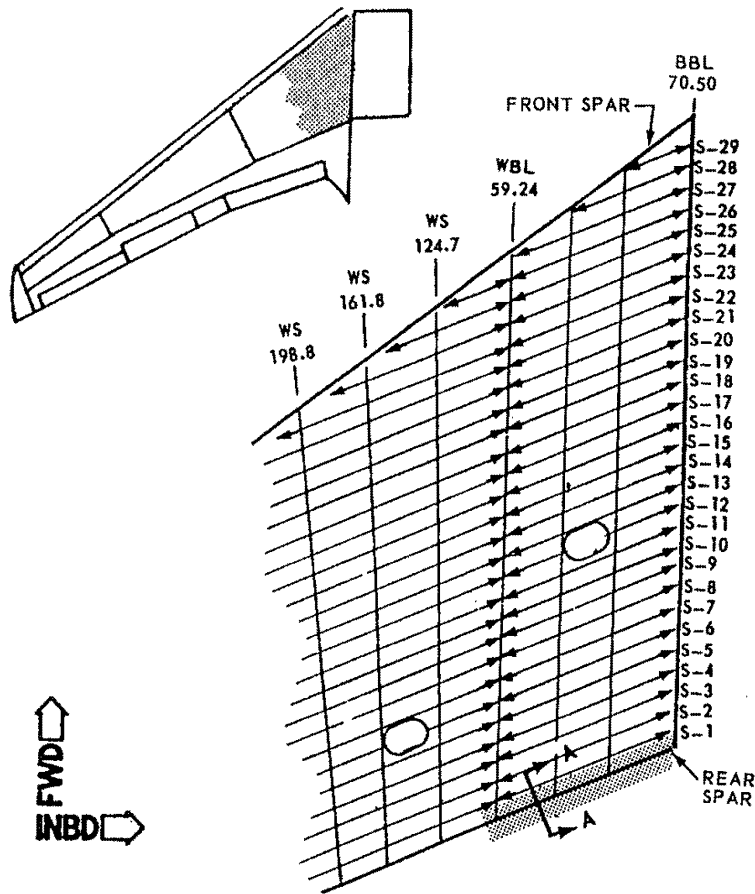

MODEL 707-300/-400 SERIES

REAR SPAR LOWER CHORD AND WING LOWER SKIN INSPECTION
BBL 70.50 THRU WBL 129.62/59.24

 INSPECTION AREA

LH WING REAR SPAR LOWER CHORD NDI INSPECTION

sabena B707	Module: LH WING + FL CTR	A/C Reg :	Check :	 31F4000526 Page 3 of 7
	Oper. : RT-MP LC	Issuer : A59513	Cert.St.: 46928	
	Type : NDT INSP	Release Date: 22.11.2006		
Spec. : NDT INSP				

LH WING REAR SPAR LOWER CHORD NDI INSPECTION

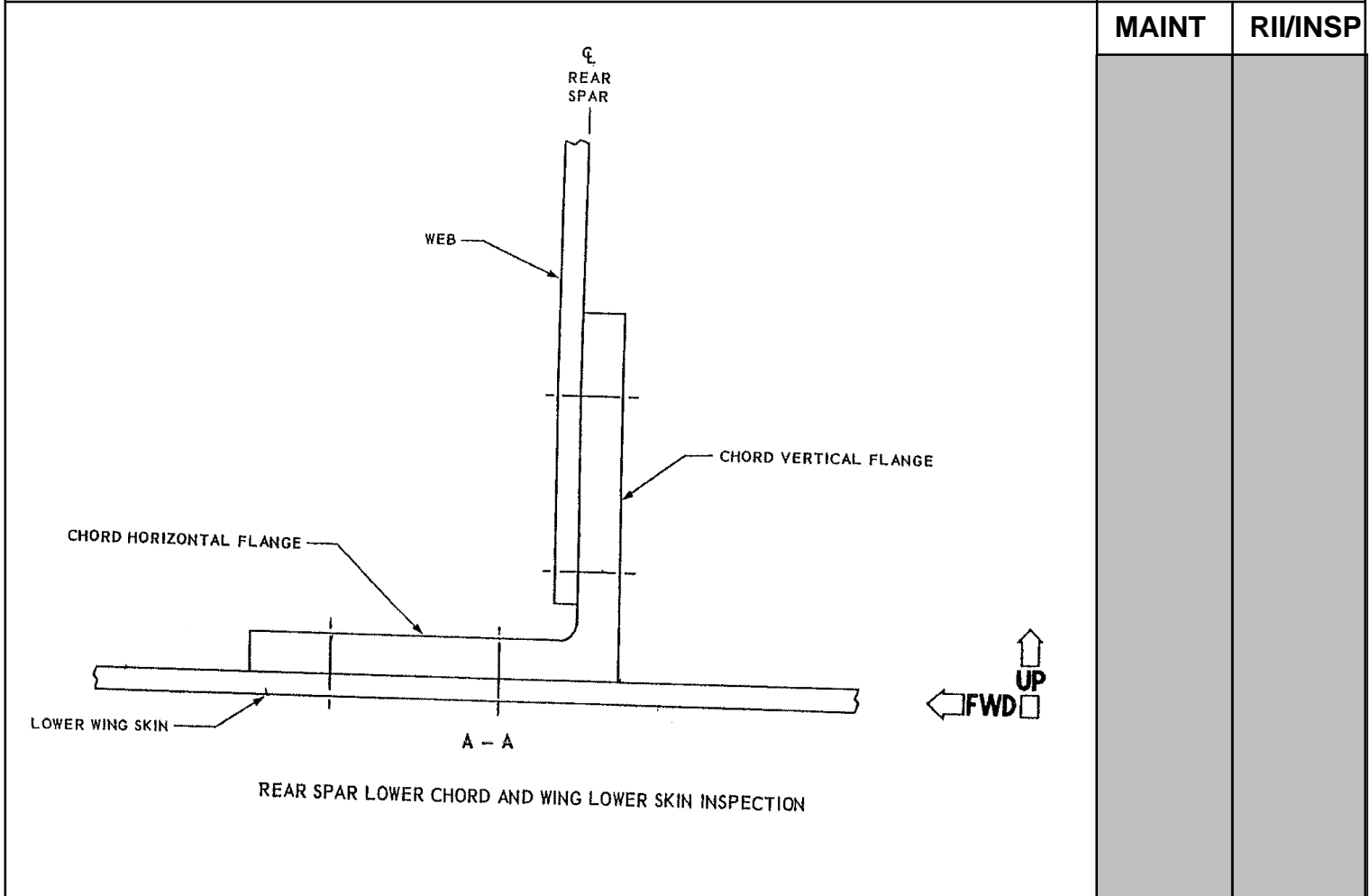

MAINT	RII/INSP

Nr.	Hardtime	Task	Spec.	Related Documents
2.	22192 CYC	E4	INS	AD 85-12-01 R1 rev 5439 MMS-328 572080 02004 rev 15.07.05 SSID 57-A45-05/C3 rev P

Check: C1
Zones: 135, 572, 584
Access: 1324 L

NRC YES NO IF YES, NUMBER(S):

LH WING REAR SPAR LOWER CHORD

LH WING REAR SPAR LOWER CHORD, WEB TERMINAL FITTING / SPAR CHORD & WING LOWER SKIN BBL 70.50 TO WBL 59.24.

Do an H.F.E.C. or X-RAY internal inspection (as required) terminal fitting horizontal surfaces (including splice members).

Refer. X-RAY, DOC D6-48023, Part 2, 57-10-07, Fig 21
Refer. HFEC, DOC D6-48023, Part 2, 57-10-07, Fig 53.

LH WING REAR SPAR LOWER CHORD NDI INSPECTION

sabena B707	Module: LH WING + FL CTR	A/C Reg :	Check :	 31F4000526 Page 4 of 7
	Oper. : RT-MP LC	Issuer : A59513	Cert.St.: 46928	
	Type : NDT INSP	Release Date: 22.11.2006		
Spec. : NDT INSP				

LH WING REAR SPAR LOWER CHORD NDI INSPECTION

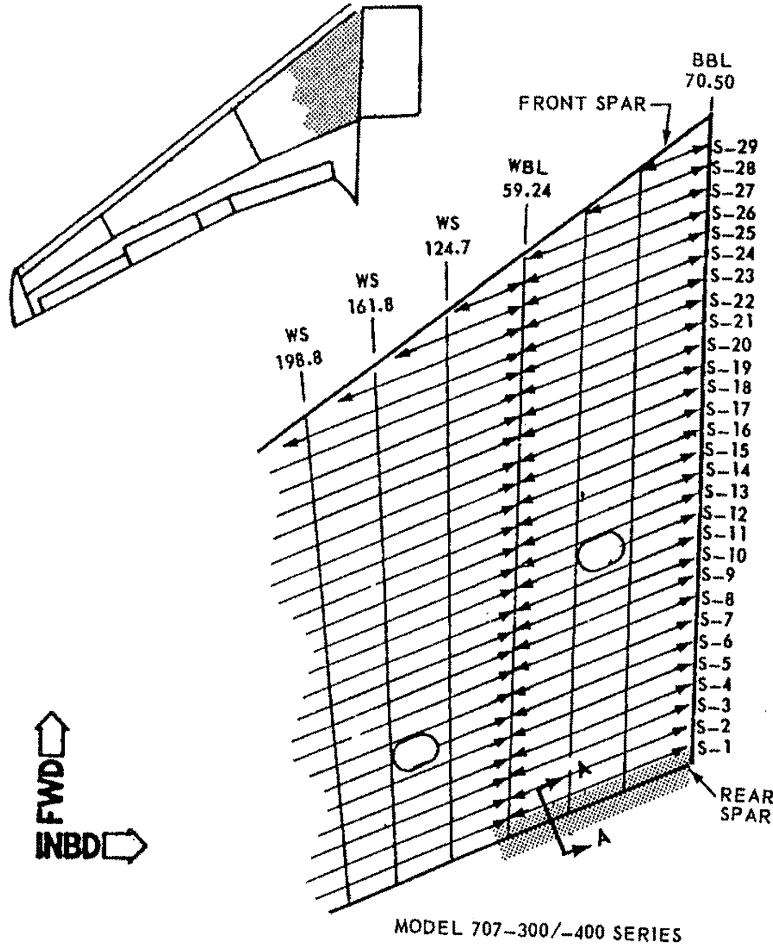

REAR SPAR LOWER CHORD AND WING LOWER SKIN INSPECTION
 BBL 70.50 THRU WBL 129.62/59.24

 INSPECTION AREA

MAINT **RII/INSP**

sabena B707	Module: LH WING + FL CTR	A/C Reg :	Check :	 31F4000526 Page 5 of 7
	Oper. : RT-MP LC	Issuer : A59513	Cert.St.: 46928	
	Type : NDT INSP	Release Date: 22.11.2006		
Spec. : NDT INSP				

LH WING REAR SPAR LOWER CHORD NDI INSPECTION

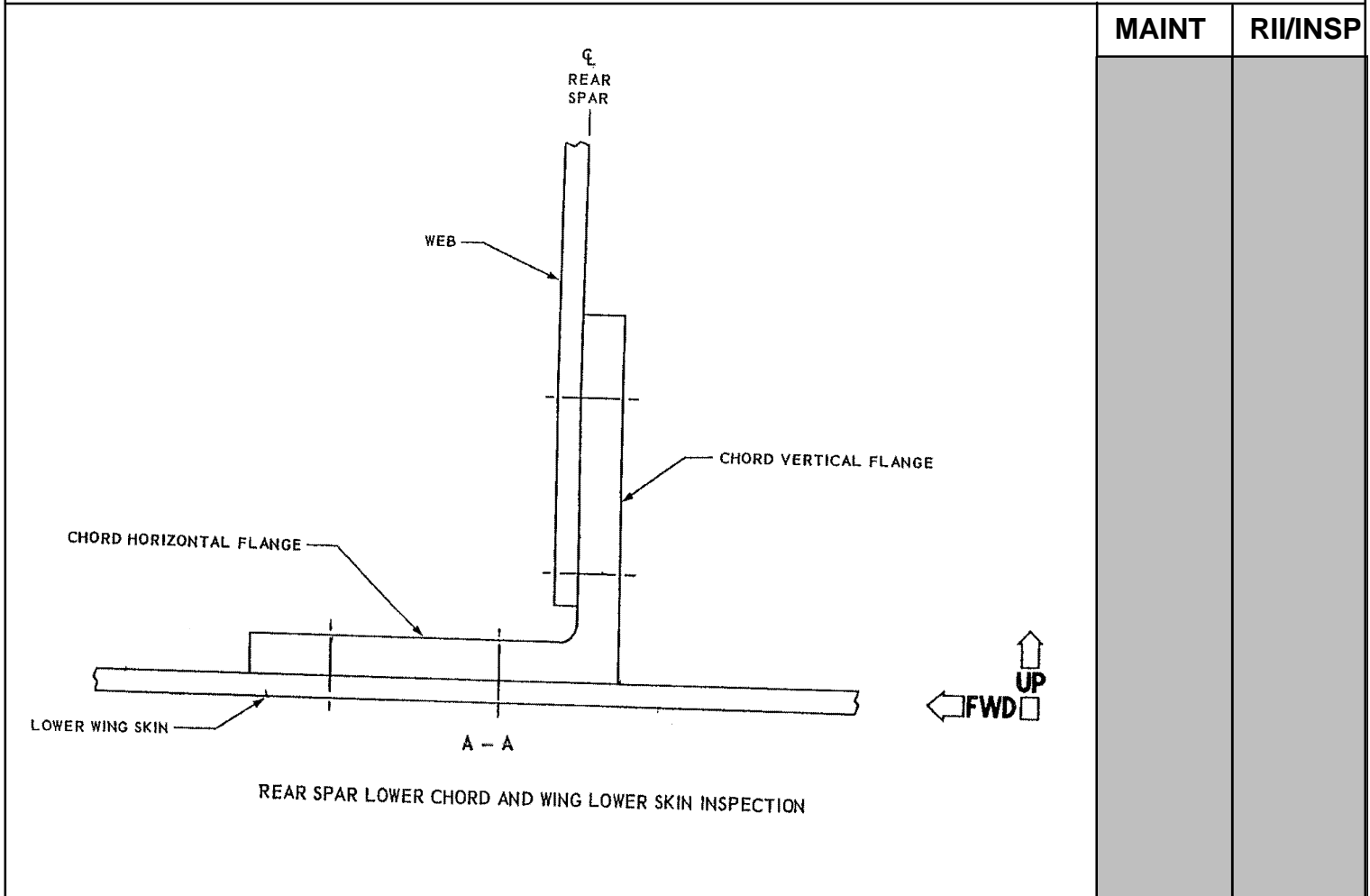

MAINT	RII/INSP

Nr.	Hardtime	Task	Spec.	Related Documents
3.		E4	INS	AD 85-12-01 R1 rev 5439 MMS-328 572080 02004 rev 15.07.05 SSID 57-A45-05/C3 rev P

Check: C1

Zones: 135, 572, 584

Access: 1324 L

NRC YES NO IF YES, NUMBER(S):

LH WING REAR SPAR LOWER CHORD

LH WING REAR SPAR LOWER CHORD, WEB TERMINAL FITTING / SPAR CHORD & WING LOWER SKIN BBL 70.50 TO WBL 59.24.

Do an H.F.E.C. or X-RAY internal inspection (as required) terminal fitting horizontal surfaces (including splice members).

Refer. X-RAY, DOC D6-48023, Part 2, 57-10-07, Fig 21
Refer. HFEC, DOC D6-48023, Part 2, 57-10-07, Fig 53.

LH WING REAR SPAR LOWER CHORD NDI INSPECTION

sabena B707	Module: LH WING + FL CTR	A/C Reg :	Check :	 31F4000526 Page 6 of 7
	Oper. : RT-MP LC	Issuer : A59513	Cert.St.: 46928	
	Type : NDT INSP	Release Date: 22.11.2006		
Spec. : NDT INSP				

LH WING REAR SPAR LOWER CHORD NDI INSPECTION

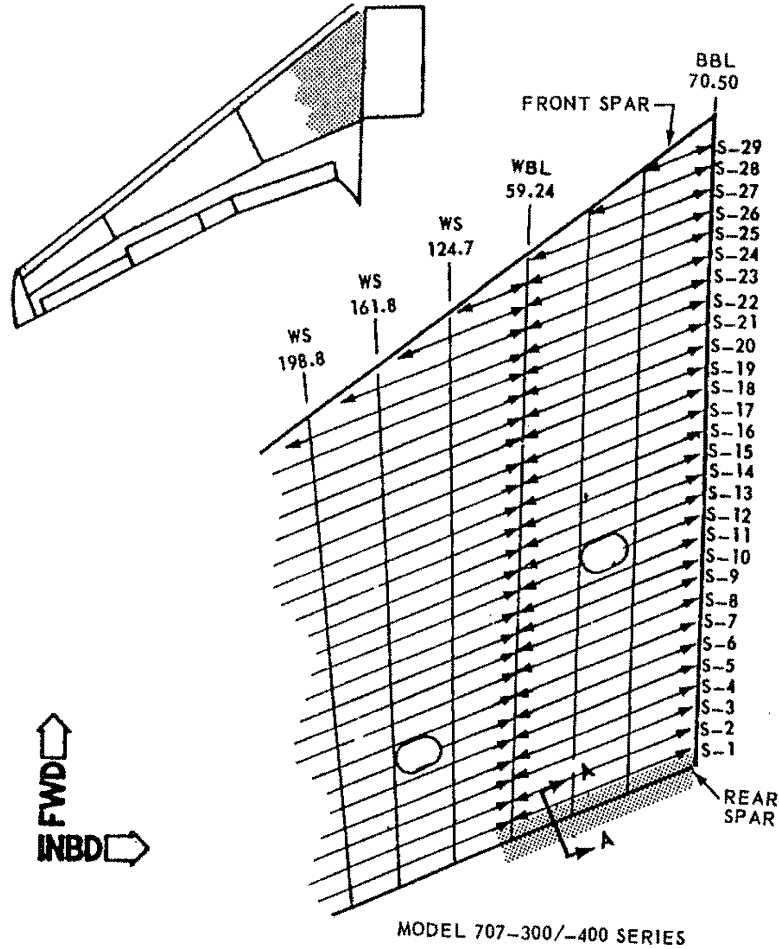

REAR SPAR LOWER CHORD AND WING LOWER SKIN INSPECTION
 BBL 70.50 THRU WBL 129.62/59.24

MAINT	RII/INSP

sabena B707	Module: LH WING + FL CTR	A/C Reg :	Check :	 31F4000526
	Oper. : RT-MP LC	Issuer : A59513	Cert.St.: 46928	
	Type : NDT INSP	Release Date: 22.11.2006	Page 7 of 7	
Spec. : NDT INSP				

LH WING REAR SPAR LOWER CHORD NDI INSPECTION

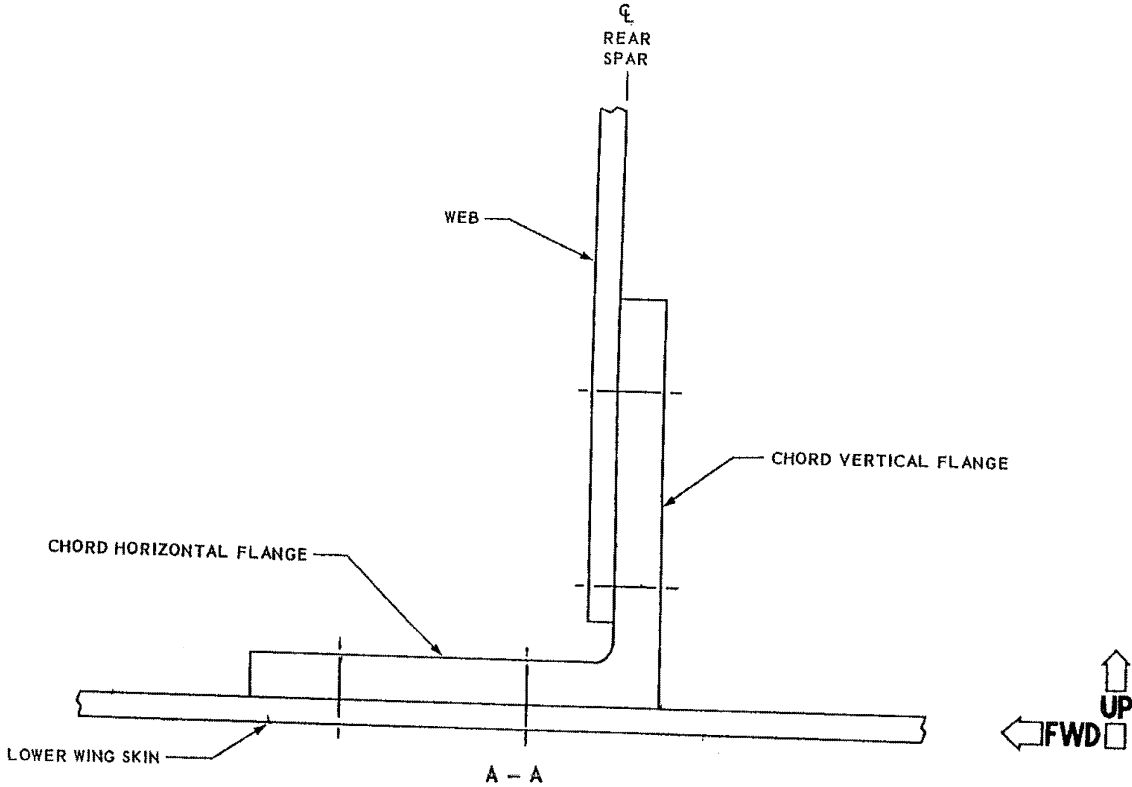

REAR SPAR LOWER CHORD AND WING LOWER SKIN INSPECTION

MAINT	RII/INSP

LH WING REAR SPAR LOWER CHORD NDI INSPECTION