



<b>sabena</b> <sup>®</sup> <b>B707</b>	Module: RH WING + FL CTR	A/C Reg :	Check :	 <b>41F2000520</b>
	Oper. : RT-MP LC			
	Type : MEC-INSP	Issuer : A59513	Cert.St.: 46928	<b>Page 1 of 7</b>
Spec. : MECH. INSP	Release Date: 22.11.2006			

**RH WING REAR SPAR LOWER CHORD INSPECTION**

Execution / Start Date:	
End Date:	

MAINT	RII/INSP

<b>sabena</b> B707	Module: RH WING + FL CTR	A/C Reg :	Check :	 <b>41F2000520</b> Page 2 of 7
	Oper. : RT-MP LC	Issuer : A59513	Cert.St.: 46928	
	Type : MEC-INSP	Release Date: 22.11.2006		
Spec. : MECH. INSP				

**RH WING REAR SPAR LOWER CHORD INSPECTION**

					<b>MAINT</b>	<b>RII/INSP</b>
Nr.	Hardtime	Task	Spec.	Related Documents		
1.	22083 CYC	E3	INS	AD 85-12-01 R1 rev 5439 MMS-328 572080 02001 rev 15.07.05 SSID 57-A45-05/A rev P		
Check: C1						
Zones: 136, 673, 685						
Access: 1324R						
NRC YES <input type="radio"/> NO <input type="radio"/>		IF YES, NUMBER(S): .....				

**RH WING REAR SPAR LOWER CHORD**

**RH WING REAR SPAR LOWER CHORD, WEB TERMINAL FITTING / SPAR CHORD & WING LOWER SKIN BBL 70.50 TO WBL 59.24.**

Do a close visual external & internal inspection of rear spar web, lower chord vertical & horizontal flanges terminal fitting/spar chord (at side of body splice) & wing lower skin in area of rear spar

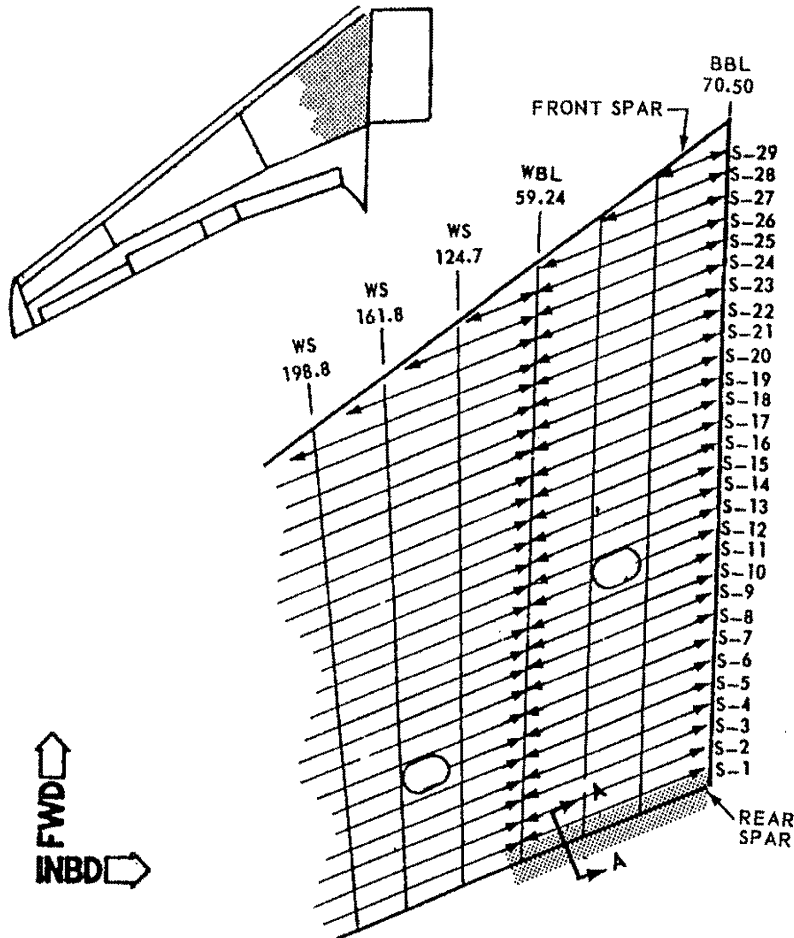

MODEL 707-300/-400 SERIES

REAR SPAR LOWER CHORD AND WING LOWER SKIN INSPECTION  
BBL 70.50 THRU WBL 129.62/59.24

 INSPECTION AREA

**RH WING REAR SPAR LOWER CHORD INSPECTION**



<b>sabena</b> <b>B707</b>	Module: RH WING + FL CTR	A/C Reg :	Check :	 <b>41F2000520</b>
	Oper. : RT-MP LC			
	Type : MEC-INSP	Issuer : A59513	Cert.St.: 46928	
Spec. : MECH. INSP	Release Date: 22.11.2006			

**RH WING REAR SPAR LOWER CHORD INSPECTION**

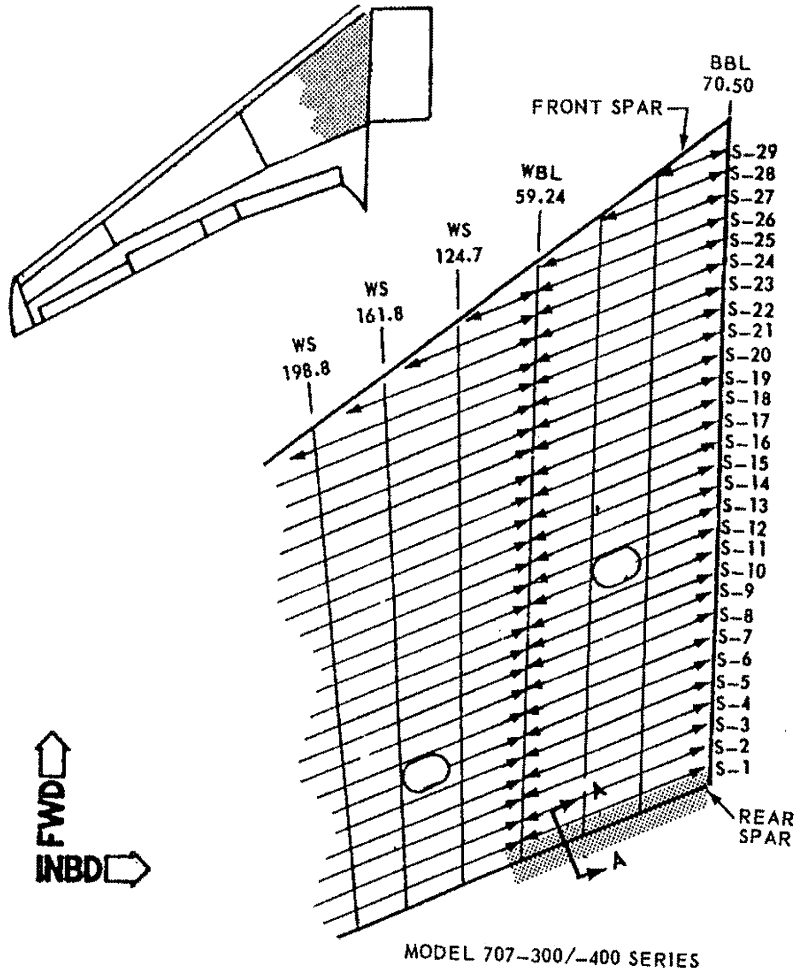

REAR SPAR LOWER CHORD AND WING LOWER SKIN INSPECTION  
 BBL 70.50 THRU WBL 129.62/59.24

 INSPECTION AREA

**MAINT**      **RII/INSP**

--	--

<b>sabena</b> B707	Module: RH WING + FL CTR	A/C Reg :	Check :	
	Oper. : RT-MP LC	Issuer : A59513	Cert.St.: 46928	
	Type : MEC-INSP	Release Date: 22.11.2006	Page 5 of 7	

**RH WING REAR SPAR LOWER CHORD INSPECTION**

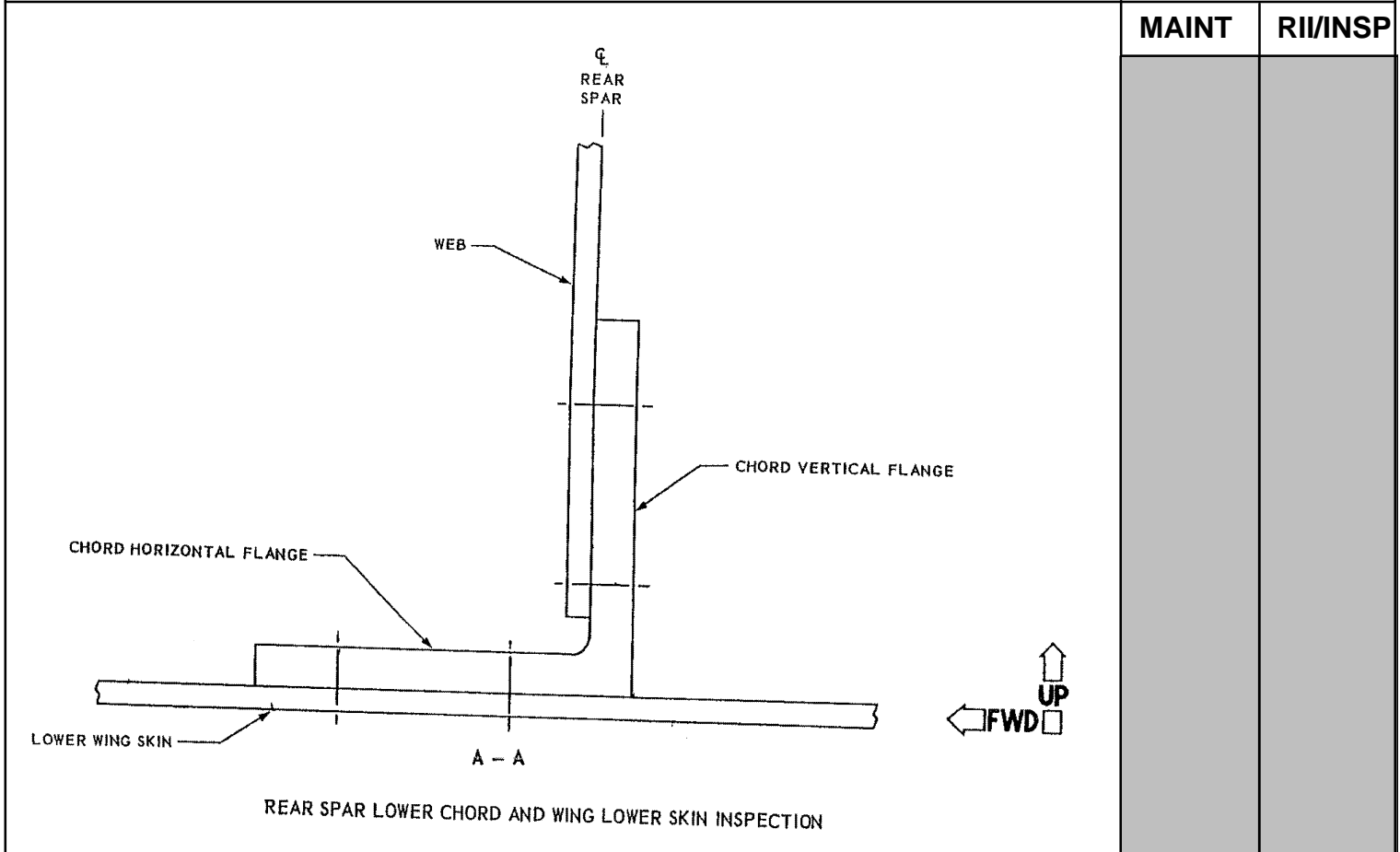

MAINT	RII/INSP

Nr.	Hardtime	Task	Spec.	Related Documents
3.		E3	INS	AD 85-12-01 R1 rev 5439 MMS-328 572080 02001 rev 15.07.05 SSID 57-A45-05/A rev P

<b>Check:</b>	C1
<b>Zones:</b>	136, 673, 685
<b>Access:</b>	1324R

NRC YES  NO  IF YES, NUMBER(S): .....

**RH WING REAR SPAR LOWER CHORD**

**RH WING REAR SPAR LOWER CHORD, WEB TERMINAL FITTING / SPAR CHORD & WING LOWER SKIN BBL 70.50 TO WBL 59.24.**

Do a close visual external & internal inspection of rear spar web, lower chord vertical & horizontal flanges terminal fitting/spar chord (at side of body splice) & wing lower skin in area of rear spar

<b>sabena</b> <b>B707</b>	Module: RH WING + FL CTR	A/C Reg :	Check :	 <b>41F2000520</b> <b>Page 6 of 7</b>
	Oper. : RT-MP LC			
	Type : MEC-INSP	Issuer : A59513	Cert.St.: 46928	
Spec. : MECH. INSP	Release Date: 22.11.2006			

**RH WING REAR SPAR LOWER CHORD INSPECTION**

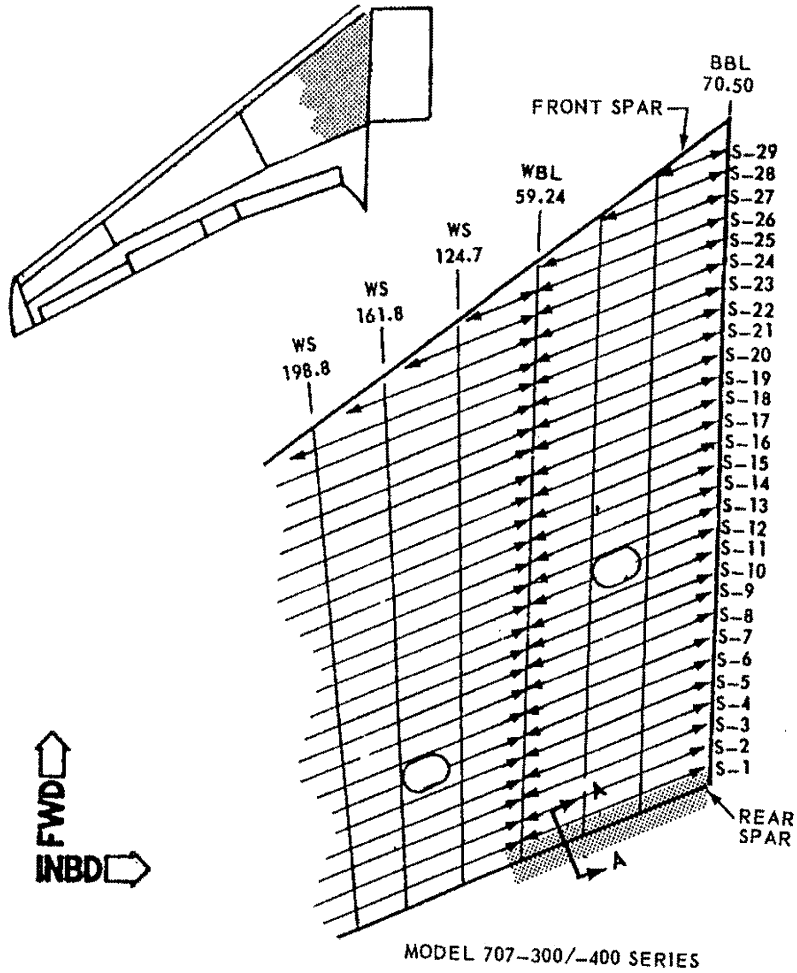

MODEL 707-300/-400 SERIES

REAR SPAR LOWER CHORD AND WING LOWER SKIN INSPECTION  
 BBL 70.50 THRU WBL 129.62/59.24

 INSPECTION AREA

**MAINT**      **RII/INSP**

<b>sabena</b> B707	Module: RH WING + FL CTR	A/C Reg :	Check :	 41F2000520
	Oper. : RT-MP LC	Issuer : A59513	Cert.St.: 46928	
	Type : MEC-INSP	Release Date: 22.11.2006	Page 7 of 7	
Spec. : MECH. INSP				

**RH WING REAR SPAR LOWER CHORD INSPECTION**

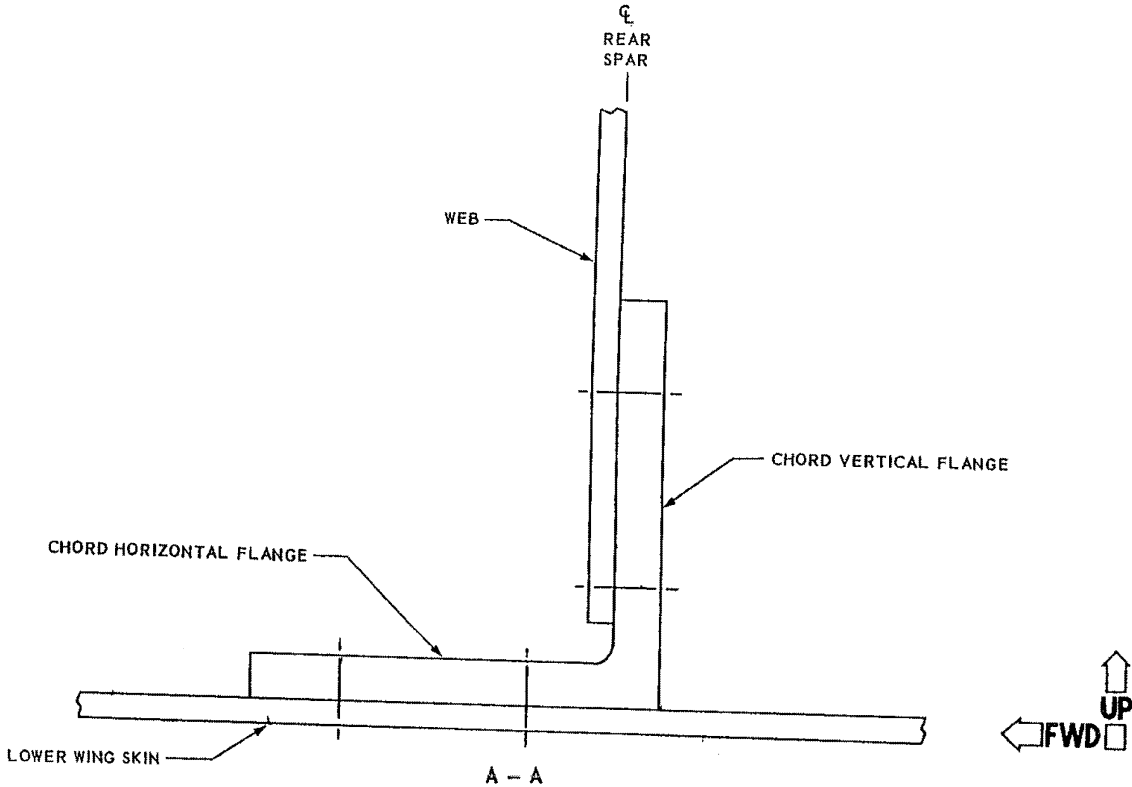
	MAINT	RII/INSP
 <p style="text-align: center;">REAR SPAR LOWER CHORD AND WING LOWER SKIN INSPECTION</p>		

**RH WING REAR SPAR LOWER CHORD INSPECTION**