

sabena B707	Module: RH WING + FL CTR	A/C Reg :	Check :	 41F3000508
	Oper. : RT-MP LC	Issuer : A43710	Cert.St.: 24828	
	Type : STRUCT-INSP	Release Date: 09.10.2001		
Spec. : MECHANIC				

AD 90-25-07 rev 6788 RH WING INT STRUCT L/E CAV FWD INSP

					MAINT	RII/INSP
Nr.	Hardtime	Task	Spec.	Related Documents		
1.		E3	MEC	AD 90-25-07 rev 6788 CPCP C57-562-01P2 rev E MMS-328 574000 02000 rev 23/04/01 SB 57-3240 rev D		
Check: C1						
Zones: 562, 563, 564						
Access: 1260 R, 1268 R, 1269 R, 1270 R, 1271 R						

RH WING INTERNAL STRUCTURE, LEADING EDGE CAVITY FWD OF FRONT SPAR INSPECTION.

- Perform inspection of exposed of internal structure of RH wing leading edge cavity fwd of front spar including the front spar and skins (except inb of L.E devices and above the engine strut area engine attachments and support fittings) with particular attention to:
 - Front spar chords.
 - Leading edge flaps and slats.
- SB 3240:** Inspect close visual the entire length of front spar lower chord for corrosion and cracks with particular attention to FS lower chord at WS 733, between WS 480 & 550 at attachment of slat actuator support fittings at WS 917, 865, 812, 760 and 711 to lower chord, inboard and outboard of the chord joint at WS 360.

CORROSION INSPECTION SUMMARY.

DESCRIPTION:	HIGHEST CORROSION LEVEL.				DR Nr.
	NO	1	2	3	
– Front spar chords.					
– Leading edge flaps and slats.					

- Clear any blocked holes or gaps that may hinder drainage.
- Apply DINITROL (in area RH wing leading edge cavity interior).

sabena B707	Module: RH WING + FL CTR	A/C Reg :	Check :	 41F3000508 Page 3 of 5
	Oper. : RT-MP LC	Issuer : A43710	Cert.St.: 24828	
	Type : STRUCT-INSP	Release Date: 09.10.2001		
	Spec. : MECHANIC			

AD 90-25-07 rev 6788

RH WING INT STRUCT L/E CAV FWD INSP

MAINT RII/INSP

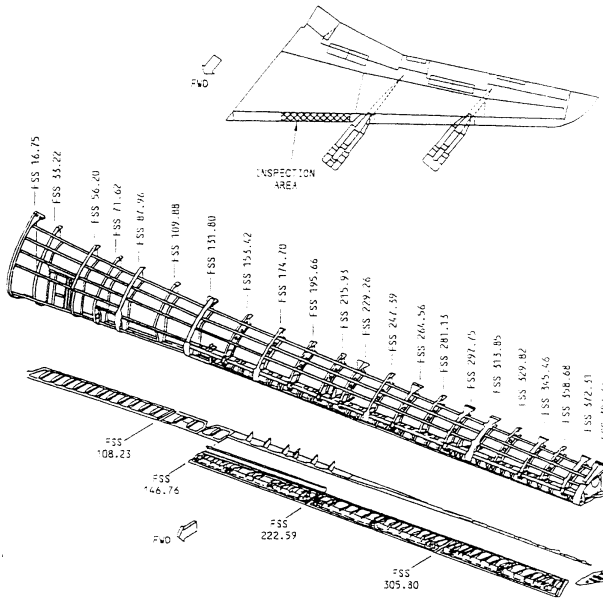

LEFT INBOARD WING LEADING EDGE STRUCTURE

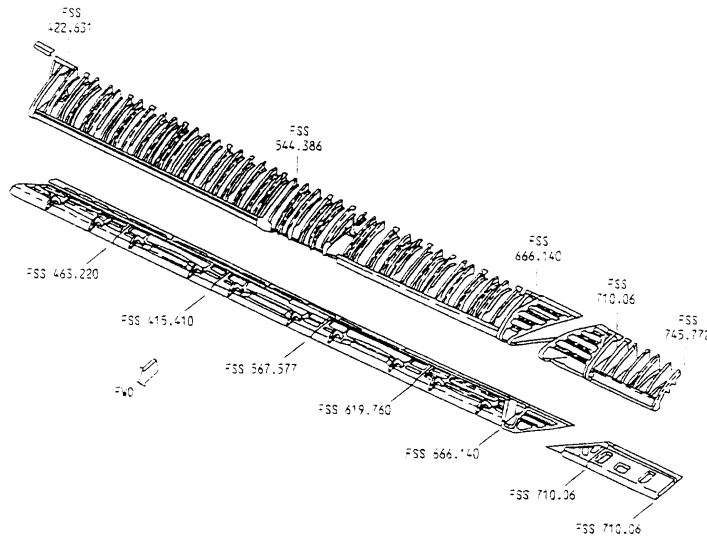
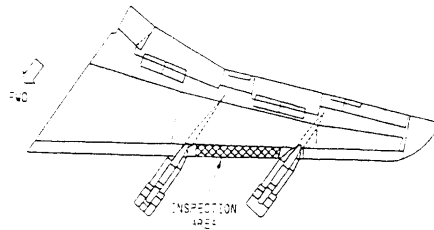

LEFT OUTBOARD WING LEADING EDGE STRUCTURE

AD 90-25-07 rev 6788

RH WING INT STRUCT L/E CAV FWD INSP

sabena B707	Module: RH WING + FL CTR	A/C Reg :	Check :	 41F3000508 Page 4 of 5
	Oper. : RT-MP LC	Issuer : A43710	Cert.St.: 24828	
	Type : STRUCT-INSP	Release Date: 09.10.2001		
Spec. : MECHANIC				

AD 90-25-07 rev 6788

RH WING INT STRUCT L/E CAV FWD INSP

MAINT RII/INSP

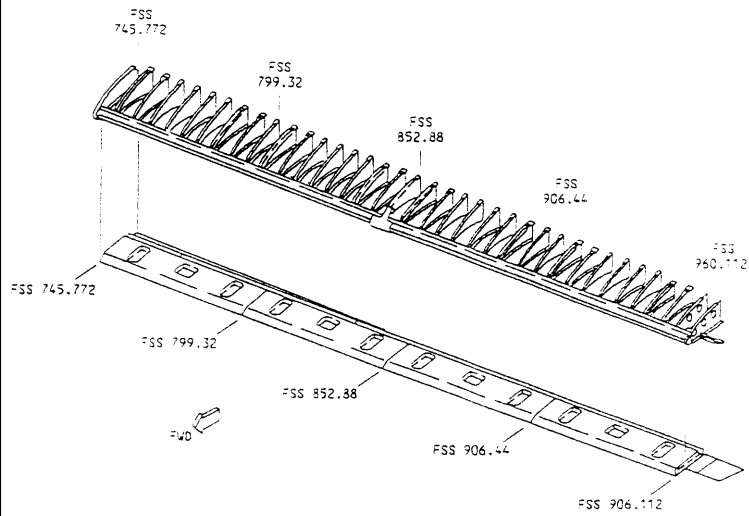
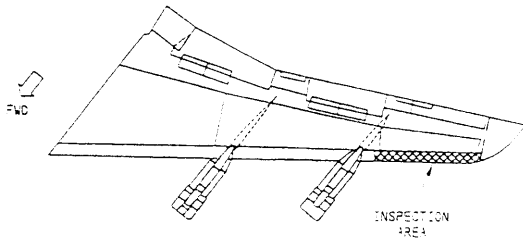

LEFT OUTBOARD WING LEADING EDGE STRUCTURE

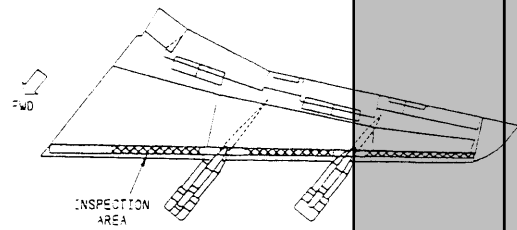

LH SIDE SHOWN
RH SIDE OPPOSITE

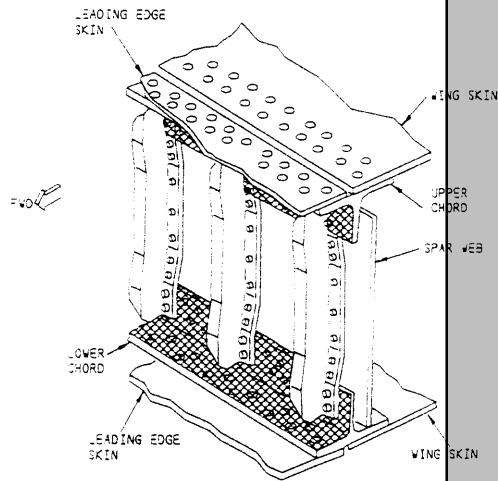

TYPICAL LEFT WING FRONT SPAR

812871

AD 90-25-07 rev 6788

RH WING INT STRUCT L/E CAV FWD INSP

sabena B707	Module: RH WING + FL CTR	A/C Reg :	Check :	 41F3000508
	Oper. : RT-MP LC	Issuer : A43710	Cert.St.: 24828	
	Type : STRUCT-INSP	Release Date: 09.10.2001	Page 5 of 5	
Spec. : MECHANIC				

AD 90-25-07 rev 6788

RH WING INT STRUCT L/E CAV FWD INSP

MAINT	RII/INSP
-------	----------

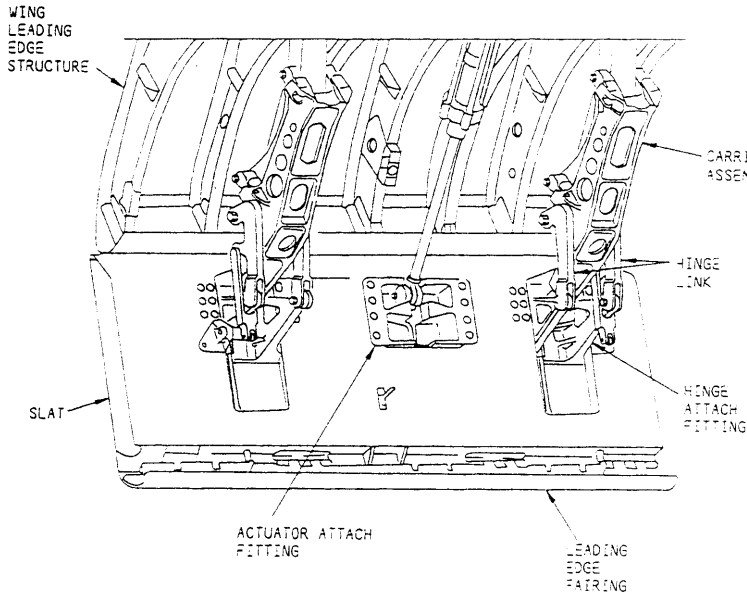

OUTBOARD SLAT SHOWN
INBOARD SLAT SIMILAR

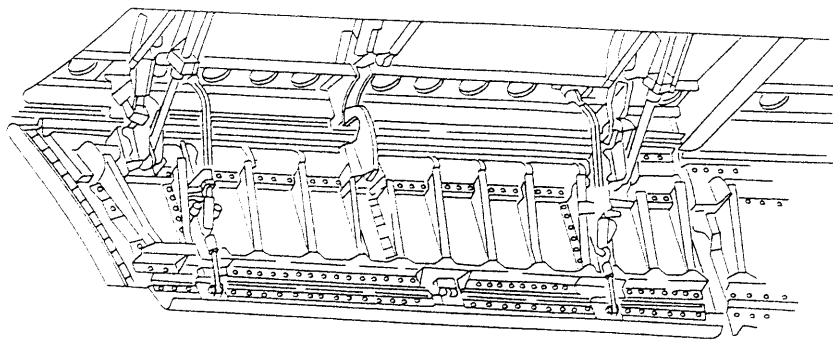

WING LEADING EDGE FLAP