



sabena [®] B707	Module: RH WING + FL CTR	A/C Reg :	Check :	 41F4000512
	Oper. : RT-MP LC			
	Type : NDT INSP	Issuer : A59513	Cert.St.: 45379	Page 1 of 3
Spec. : MECH. INSP	Release Date: 11.09.2008			

AD 04-22-24 rev . RH WING F/S CHORD HFEC INSP (4/4)

		MAINT	RII/INSP
Execution / Start Date:			
End Date:			

sabena B707	Module: RH WING + FL CTR	A/C Reg :	Check :	 41F4000512 Page 2 of 3
	Oper. : RT-MP LC	Issuer : A59513	Cert.St.: 45379	
	Type : NDT INSP	Release Date: 11.09.2008		
Spec. : MECH. INSP				

AD 04-22-24 rev . RH WING F/S CHORD HFEC INSP (4/4)

					MAINT	RII/INSP									
Nr.	Hardtime	Task	Spec.	Related Documents											
1.		E4 S	MEC	AD 01-08-02 rev 12179 AD 04-22-24 rev . AD 86-11-06 rev . MMS-328 574040 01001 rev 09.08.06 SB 57-3240 rev 4											
Check: C															
Zones: 600															
Access:															
NRC YES <input type="radio"/> NO <input type="radio"/> IF YES, NUMBER(S):															
<p>CONDITIONS: – L.E flaps, slats & trailing edge flaps full extended position.</p> <p>–Upper & lower chord externally exposed surfaces from wing-to-body joint to the wing tip = CLEAN.</p> <p><u>RH WING FRONT SPAR CHORDS INSPECTION.</u></p> <p><u>NOTE: Added annex for removal/installation parts on pt 1.</u></p> <ol style="list-style-type: none"> Remove acces panels, covers, doors & any other removal components to get acces to the entire length of the front spar chords. Perform inspection HFEC of the entire length of the external surfaces of the front wing spar & of the internal surfaces of the front spar chords in the wing dry bays for corrosion & cracks, with special attention around the heads of fasteners, around the edges of fittings, brackets & stiffeners attached to the chord, & in the radius between the vertical & horizontal flange of chord. In dry bay, do the inspection in the radius of the upper & lower chords to the edge of spar web. If paint discoloration, blistering, raised or rough spots in the paint finish are found, scrape off the paint to determine extend of damage. Check suspect crack indications with a mirror, magnifying lenses etc... <p><u>If cracks:</u> Report to engineering as crack, do not drill cracks or install repairs given in rev 3 of SB 3240.</p> <ol style="list-style-type: none"> If no corrosion or cracks are found apply AV 30 to the exposed surfaces of the upper & lower chords on front spar. 															
<table border="1" style="margin-left: auto; margin-right: auto;"> <thead> <tr> <th colspan="3">FINDINGS</th> </tr> </thead> <tbody> <tr> <td>OK</td> <td>CT:</td> <td></td> </tr> <tr> <td>NOT OK</td> <td>CT:</td> <td>DR.nr:</td> </tr> </tbody> </table>					FINDINGS			OK	CT:		NOT OK	CT:	DR.nr:		
FINDINGS															
OK	CT:														
NOT OK	CT:	DR.nr:													
6. Install acces panels, covers, doors & any components removed at pt 1 (see annex).															

AD 04-22-24 rev . RH WING F/S CHORD HFEC INSP (4/4)

sabena B707	Module: RH WING + FL CTR	A/C Reg :	Check :	 41F4000512 Page 3 of 3
	Oper. : RT-MP LC	Issuer : A59513	Cert.St.: 45379	
	Type : NDT INSP	Release Date: 11.09.2008		
Spec. : MECH. INSP				

AD 04-22-24 rev . RH WING F/S CHORD HFEC INSP (4/4)

MAINT RII/INSP

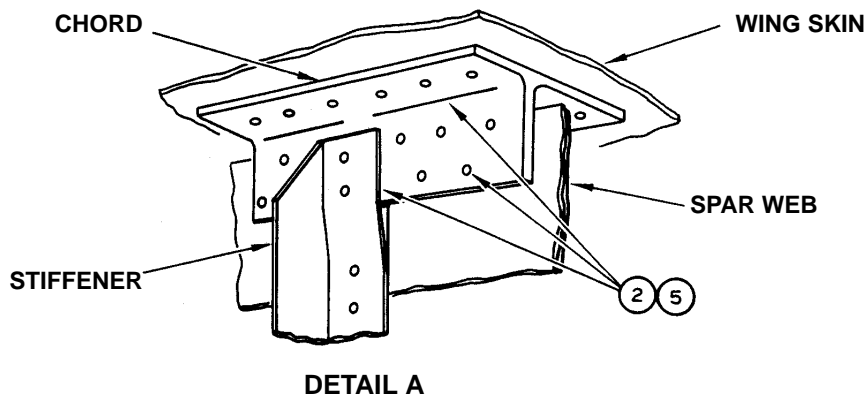
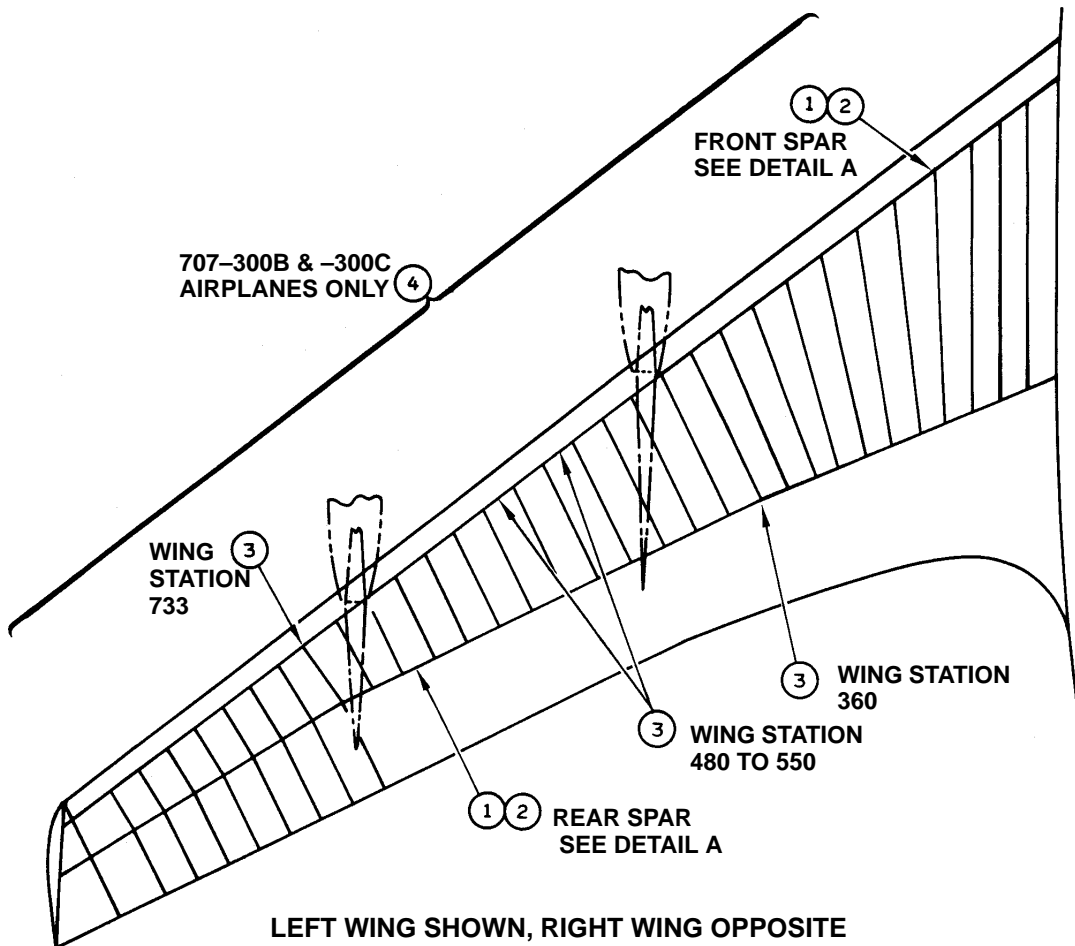

TYPICAL UPPER & LOWER CHORD

FIGURE 1. SPAR CHORD INSPECTION