

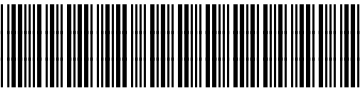

sabena B707	Module: RH WING + FL CTR	A/C Reg :	Check :	 41F4000515
	Oper. : RT-MP LC			
	Type : NDT INSP	Issuer : A59513	Cert.St.: 46928	Page 1 of 7
Spec. : NDT INSP	Release Date: 22.11.2006			

RH WING REAR SPAR LOWER CHORD NDI INSPECTION

Execution / Start Date:	
End Date:	

MAINT	RII/INSP

sabena B707	Module: RH WING + FL CTR	A/C Reg :	Check :	 41F4000515
	Oper. : RT-MP LC	Issuer : A59513	Cert.St.: 46928	
	Type : NDT INSP	Release Date: 22.11.2006	Page 2 of 7	
Spec. : NDT INSP				

RH WING REAR SPAR LOWER CHORD NDI INSPECTION

					MAINT	RII/INSP
Nr.	Hardtime	Task	Spec.	Related Documents		
1.	22083 CYC	E4	NDT	AD 85-12-01 R1 rev 5439 MMS-328 572080 02002 rev 15.07.05 SSID 57-A45-05/C1 rev P		
Check: C1						
Zones: 136, 673, 685						
Access: 1324R						
NRC YES <input type="radio"/> NO <input type="radio"/>		IF YES, NUMBER(S):				

RH WING REAR SPAR LOWER CHORD

RH WING REAR SPAR LOWER CHORD, WEB TERMINAL FITTING / SPAR CHORD & WING LOWER SKIN BBL 70.50 TO WBL 59.24.

Do an X-RAY internal inspection of rear spar chord horizontal flange at all fastener locations.
Refer. DOC D6-48023, Part 2, 57-10-07, Fig 21.

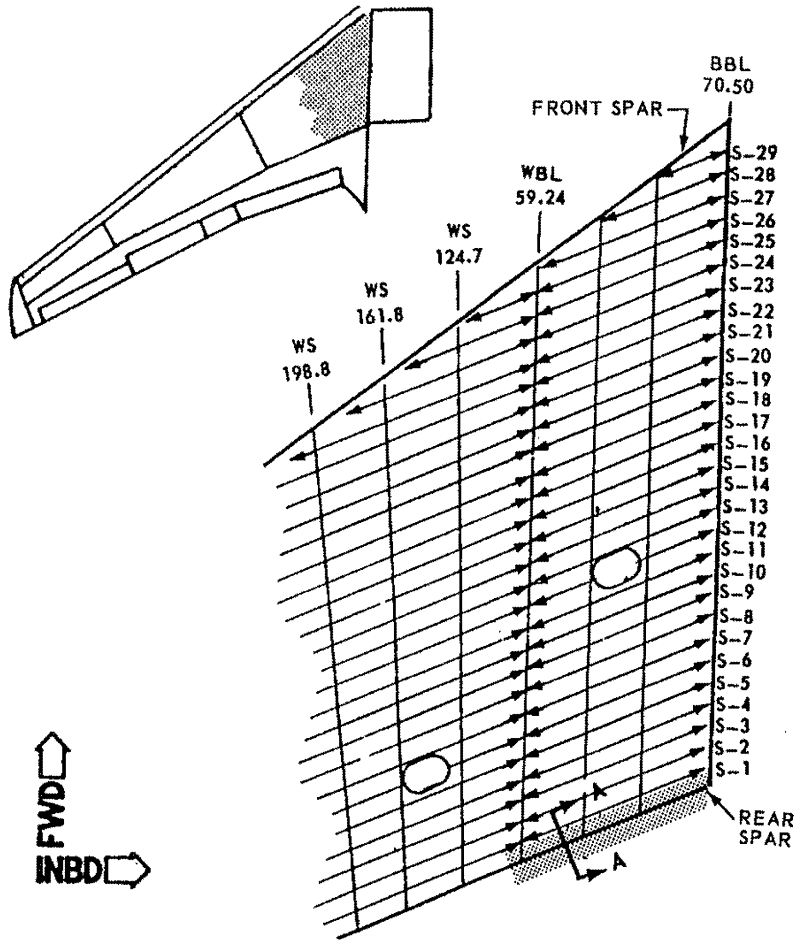

MODEL 707-300/-400 SERIES

REAR SPAR LOWER CHORD AND WING LOWER SKIN INSPECTION
BBL 70.50 THRU WBL 129.62/59.24

 INSPECTION AREA

RH WING REAR SPAR LOWER CHORD NDI INSPECTION

sabena B707	Module: RH WING + FL CTR	A/C Reg :	Check :	 41F4000515 Page 3 of 7
	Oper. : RT-MP LC	Issuer : A59513	Cert.St.: 46928	
	Type : NDT INSP	Release Date: 22.11.2006		
Spec. : NDT INSP				

RH WING REAR SPAR LOWER CHORD NDI INSPECTION

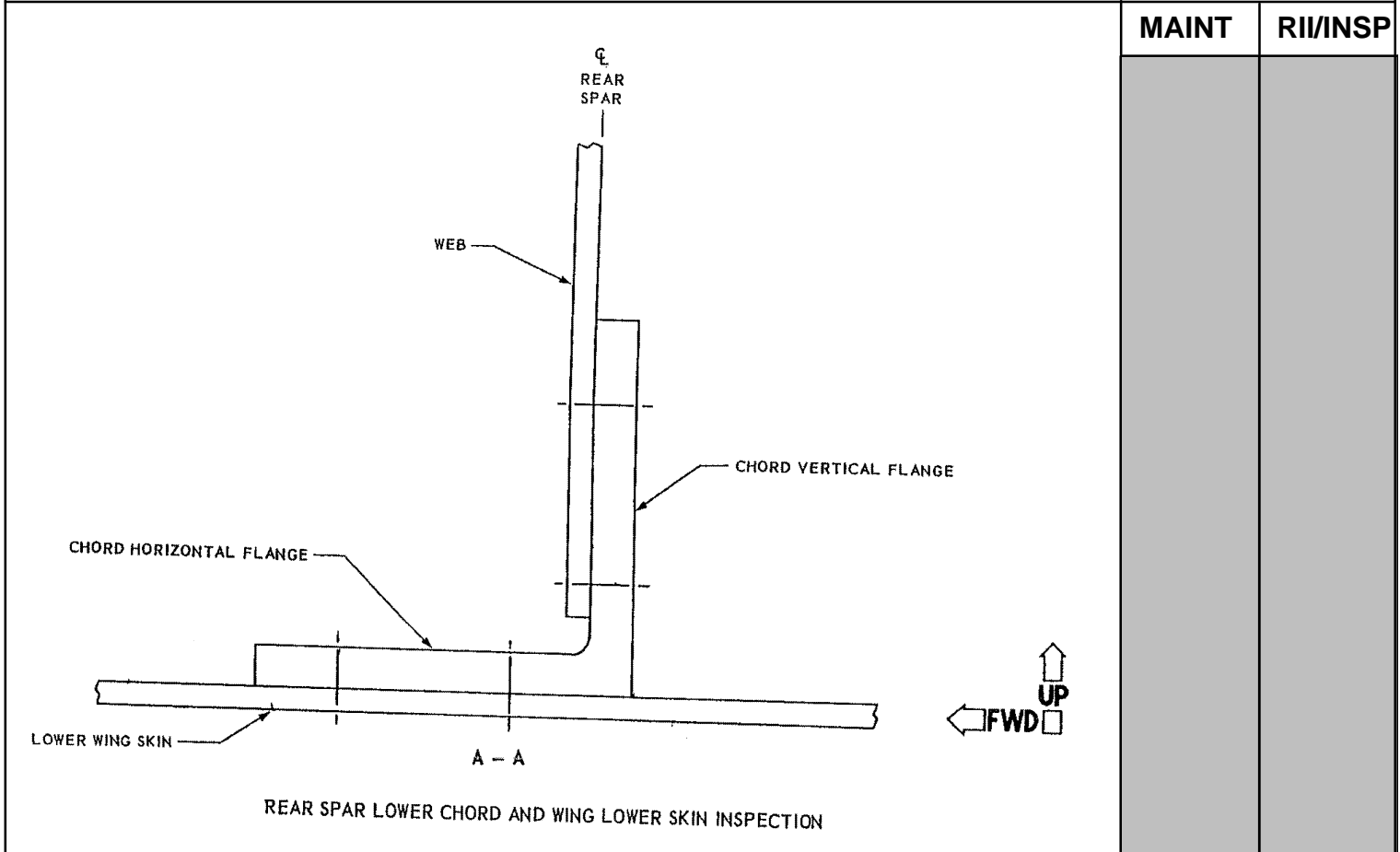

MAINT	RII/INSP

Nr.	Hardtime	Task	Spec.	Related Documents
2.	22192 CYC	E4	INS	AD 85-12-01 R1 rev 5439 MMS-328 572080 02002 rev 15.07.05 SSID 57-A45-05/C1 rev P

Check: C1

Zones: 136, 673, 685

Access: 1324R

NRC YES NO IF YES, NUMBER(S):

RH WING REAR SPAR LOWER CHORD

RH WING REAR SPAR LOWER CHORD, WEB TERMINAL FITTING / SPAR CHORD & WING LOWER SKIN BBL 70.50 TO WBL 59.24.

Do an X-RAY internal inspection of rear spar chord horizontal flange at all fastener locations.
Refer. DOC D6-48023, Part 2, 57-10-07, Fig 21.

sabena B707	Module: RH WING + FL CTR	A/C Reg :	Check :	 41F4000515 Page 4 of 7
	Oper. : RT-MP LC	Issuer : A59513	Cert.St.: 46928	
	Type : NDT INSP	Release Date: 22.11.2006		
Spec. : NDT INSP				

RH WING REAR SPAR LOWER CHORD NDI INSPECTION

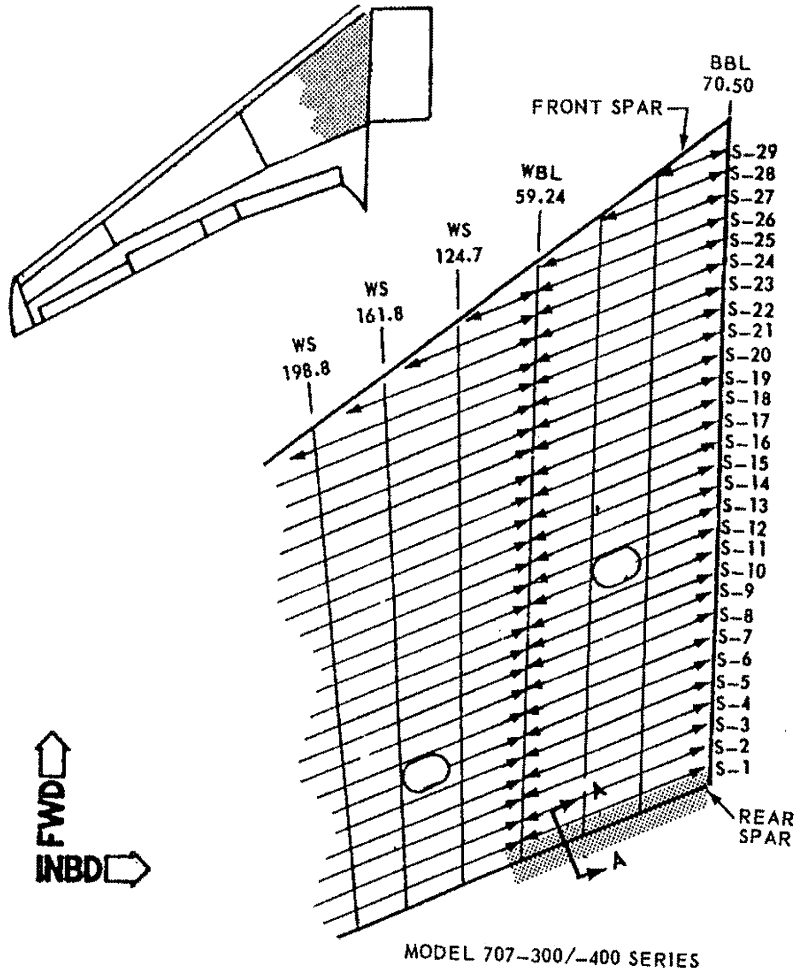

REAR SPAR LOWER CHORD AND WING LOWER SKIN INSPECTION
BBL 70.50 THRU WBL 129.62/59.24

 INSPECTION AREA

MAINT	RII/INSP

sabena B707	Module: RH WING + FL CTR	A/C Reg :	Check :	 41F4000515 Page 6 of 7
	Oper. : RT-MP LC	Issuer : A59513	Cert.St.: 46928	
	Type : NDT INSP	Release Date: 22.11.2006		
Spec. : NDT INSP				

RH WING REAR SPAR LOWER CHORD NDI INSPECTION

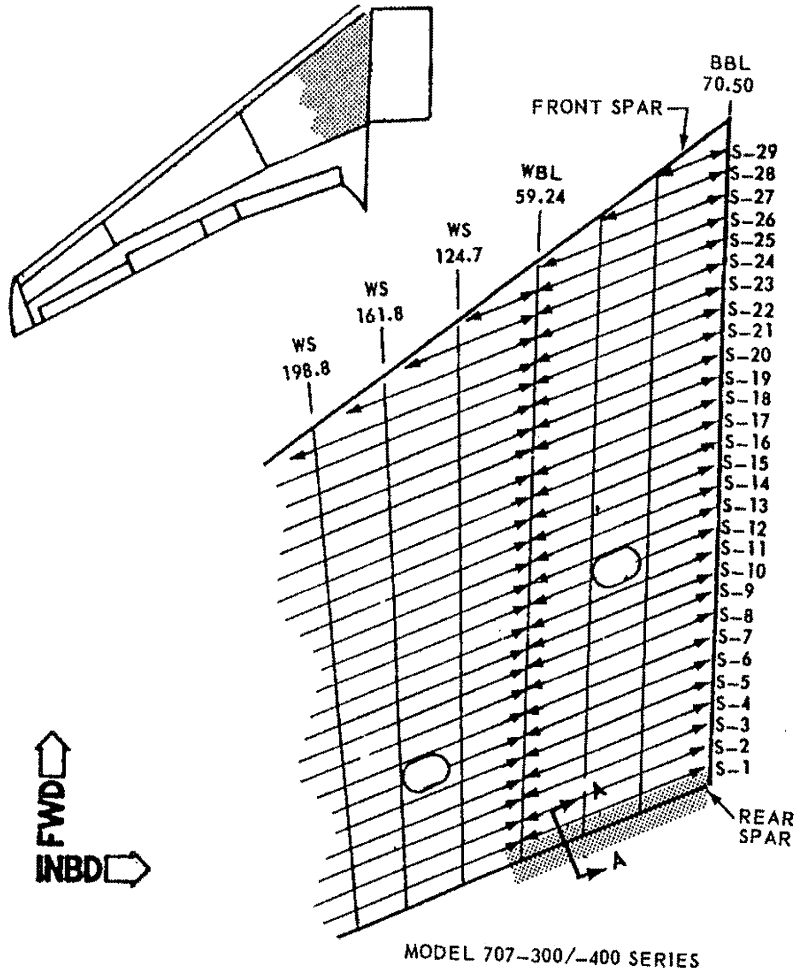

MODEL 707-300/-400 SERIES
 REAR SPAR LOWER CHORD AND WING LOWER SKIN INSPECTION
 BBL 70.50 THRU WBL 129.62/59.24

MAINT	RII/INSP

sabena B707	Module: RH WING + FL CTR	A/C Reg :	Check :	 41F4000515
	Oper. : RT-MP LC	Issuer : A59513	Cert.St.: 46928	
	Type : NDT INSP	Release Date: 22.11.2006	Page 7 of 7	
Spec. : NDT INSP				

RH WING REAR SPAR LOWER CHORD NDI INSPECTION

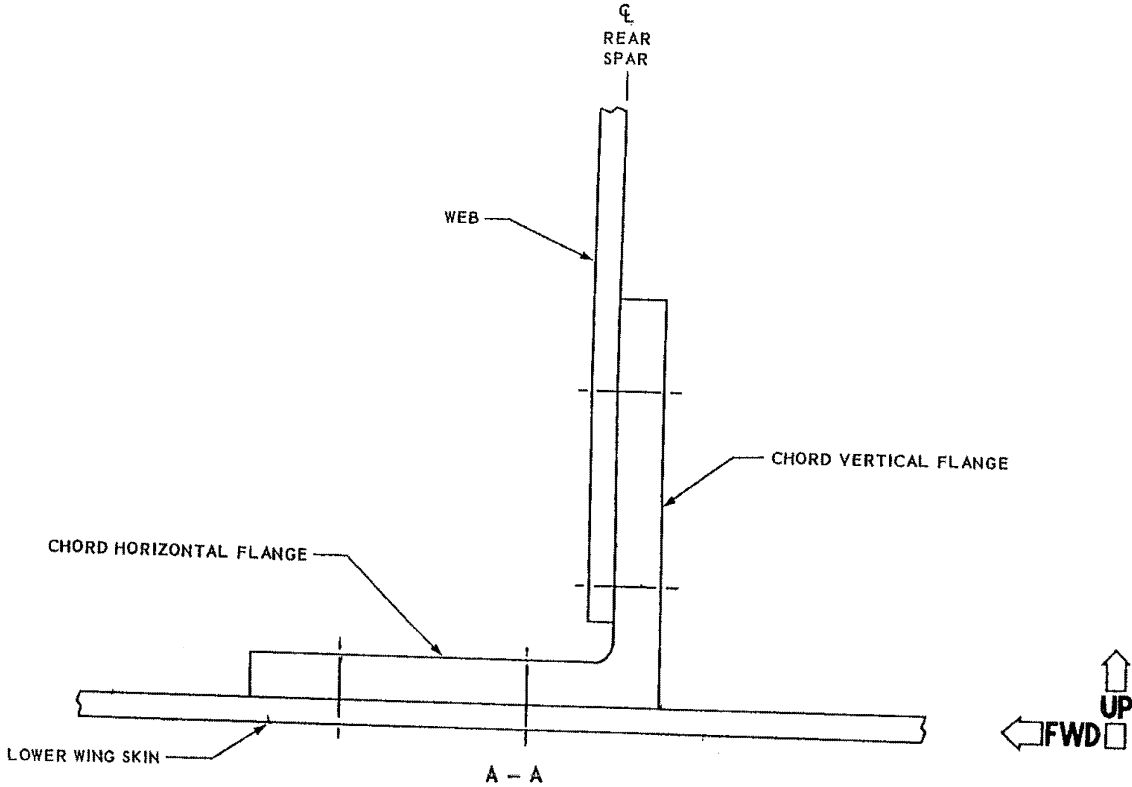

REAR SPAR LOWER CHORD AND WING LOWER SKIN INSPECTION

MAINT	RII/INSP

RH WING REAR SPAR LOWER CHORD NDI INSPECTION