

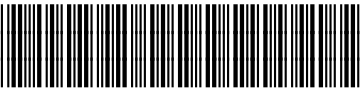

<b>sabena</b> <b>B707</b>	Module: RH WING + FL CTR	A/C Reg :	Check :	 <b>41F4000516</b>
	Oper. : RT-MP LC			
	Type : NDT INSP	Issuer : A59513	Cert.St.: 46928	<b>Page 1 of 7</b>
Spec. : NDT INSP	Release Date: 22.11.2006			

**RH WING REAR SPAR LOWER CHORD NDI INSPECTION**

Execution / Start Date:	
End Date:	

MAINT	RII/INSP

<b>sabena</b> <b>B707</b>	Module: RH WING + FL CTR	A/C Reg :	Check :	 <b>41F4000516</b> <b>Page 2 of 7</b>
	Oper. : RT-MP LC	Issuer : A59513	Cert.St.: 46928	
	Type : NDT INSP	Release Date: 22.11.2006		
Spec. : NDT INSP				

**RH WING REAR SPAR LOWER CHORD NDI INSPECTION**

					<b>MAINT</b>	<b>RII/INSP</b>
Nr.	Hardtime	Task	Spec.	Related Documents		
1.	22083 CYC	E4	NDT	AD 85-12-01 R1 rev 5439 MMS-328 572080 02003 rev 15.07.05 SSID 57-A45-05/C2 rev P		
<b>Check:</b> C1						
<b>Zones:</b> 136, 674, 685						
<b>Access:</b> 1324R						
NRC YES <input type="radio"/> NO <input type="radio"/>		IF YES, NUMBER(S): .....				

**RH WING REAR SPAR LOWER CHORD**

**RH WING REAR SPAR LOWER CHORD, WEB TERMINAL FITTING / SPAR CHORD & WING LOWER SKIN BBL 70.50 TO WBL 59.24.**

Do an H.F.E.C. internal inspection of wing lower skin, chord splice & all areas where presence of secondary structure impaired external inspection.  
Refer. DOC D6-48023, Part 6, 57-10-07, Fig 53

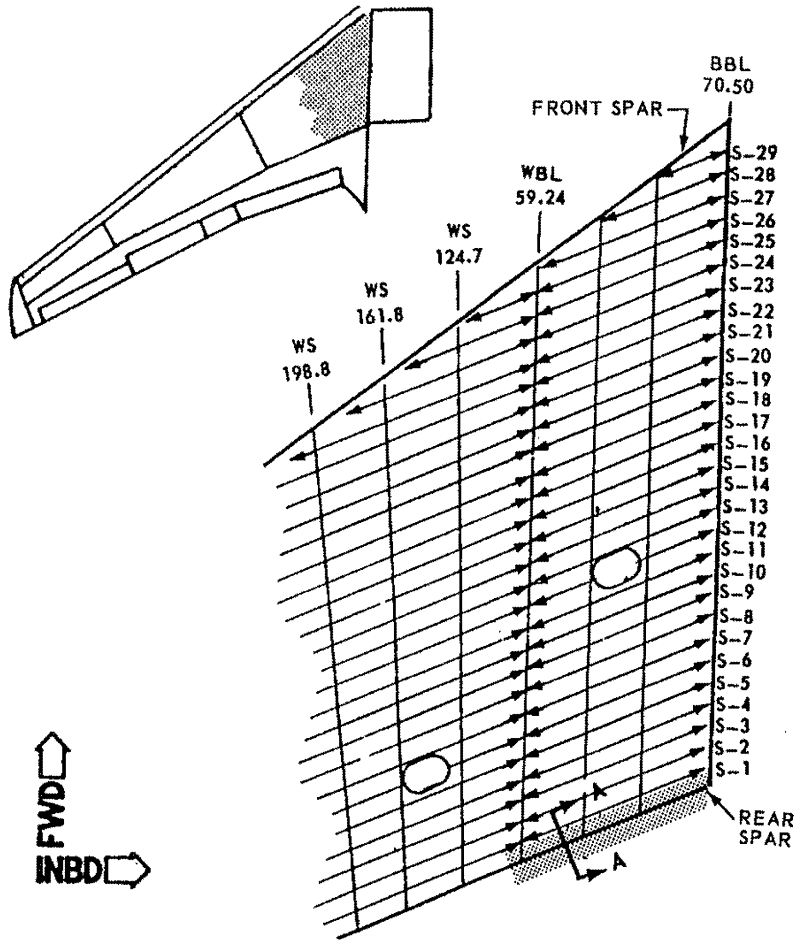

REAR SPAR LOWER CHORD AND WING LOWER SKIN INSPECTION  
BBL 70.50 THRU WBL 129.62/59.24

 INSPECTION AREA

**RH WING REAR SPAR LOWER CHORD NDI INSPECTION**

<b>sabena</b> B707	Module: RH WING + FL CTR	A/C Reg :	Check :	 41F4000516 Page 3 of 7
	Oper. : RT-MP LC	Issuer : A59513	Cert.St.: 46928	
	Type : NDT INSP	Release Date: 22.11.2006		
Spec. : NDT INSP				

**RH WING REAR SPAR LOWER CHORD NDI INSPECTION**

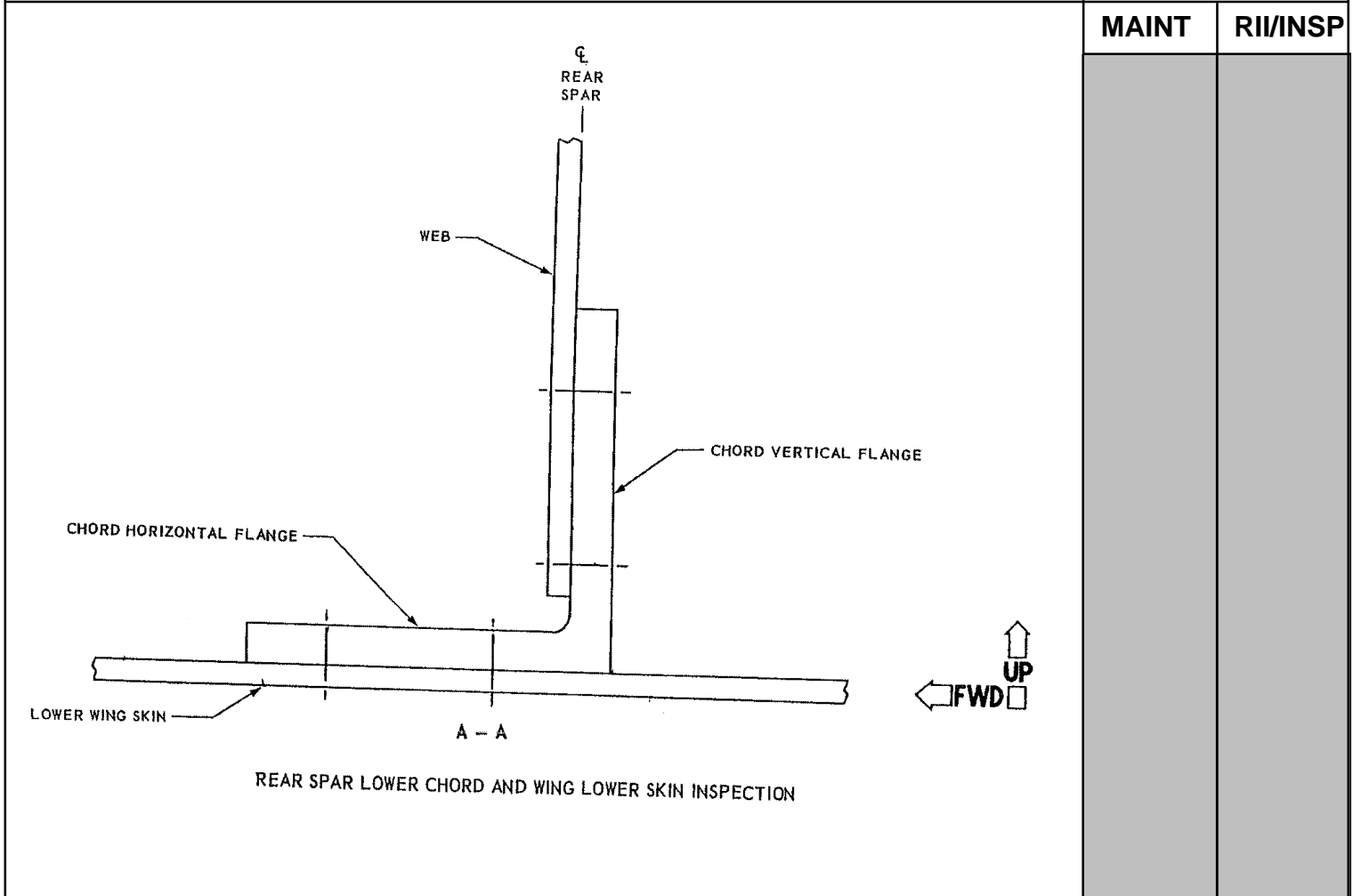

MAINT	RII/INSP

Nr.	Hardtime	Task	Spec.	Related Documents
2.	22192 CYC	E4	INS	AD 85-12-01 R1 rev 5439 MMS-328 572080 02003 rev 15.07.05 SSID 57-A45-05/C2 rev P

**Check:** C1

**Zones:** 136, 673, 685

**Access:** 1324R

NRC YES  NO  IF YES, NUMBER(S): .....

**RH WING REAR SPAR LOWER CHORD**

**RH WING REAR SPAR LOWER CHORD, WEB TERMINAL FITTING / SPAR CHORD & WING LOWER SKIN BBL 70.50 TO WBL 59.24.**

Do an H.F.E.C. internal inspection of wing lower skin, chord splice & all areas where presence of secondary structure impaired external inspection.

Refer. DOC D6-48023, Part 6, 57-10-07, Fig 53

**RH WING REAR SPAR LOWER CHORD NDI INSPECTION**

<b>sabena</b> B707	Module: RH WING + FL CTR	A/C Reg :	Check :	 <b>41F4000516</b> Page 4 of 7
	Oper. : RT-MP LC	Issuer : A59513	Cert.St.: 46928	
	Type : NDT INSP	Release Date: 22.11.2006		
Spec. : NDT INSP				

**RH WING REAR SPAR LOWER CHORD NDI INSPECTION**

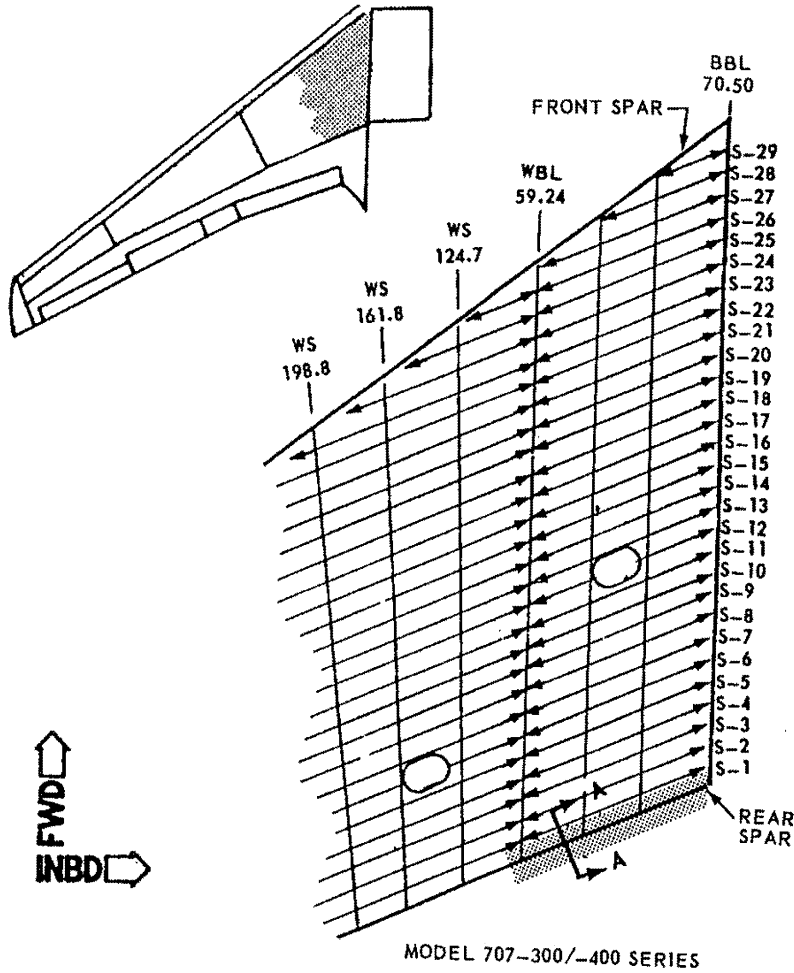

REAR SPAR LOWER CHORD AND WING LOWER SKIN INSPECTION  
 BBL 70.50 THRU WBL 129.62/59.24

 INSPECTION AREA

MAINT	RII/INSP

<b>sabena</b> B707	Module: RH WING + FL CTR	A/C Reg :	Check :	
	Oper. : RT-MP LC			
	Type : NDT INSP	Issuer : A59513	Cert.St.: 46928	41F4000516
Spec. : NDT INSP	Release Date: 22.11.2006		Page 5 of 7	

**RH WING REAR SPAR LOWER CHORD NDI INSPECTION**

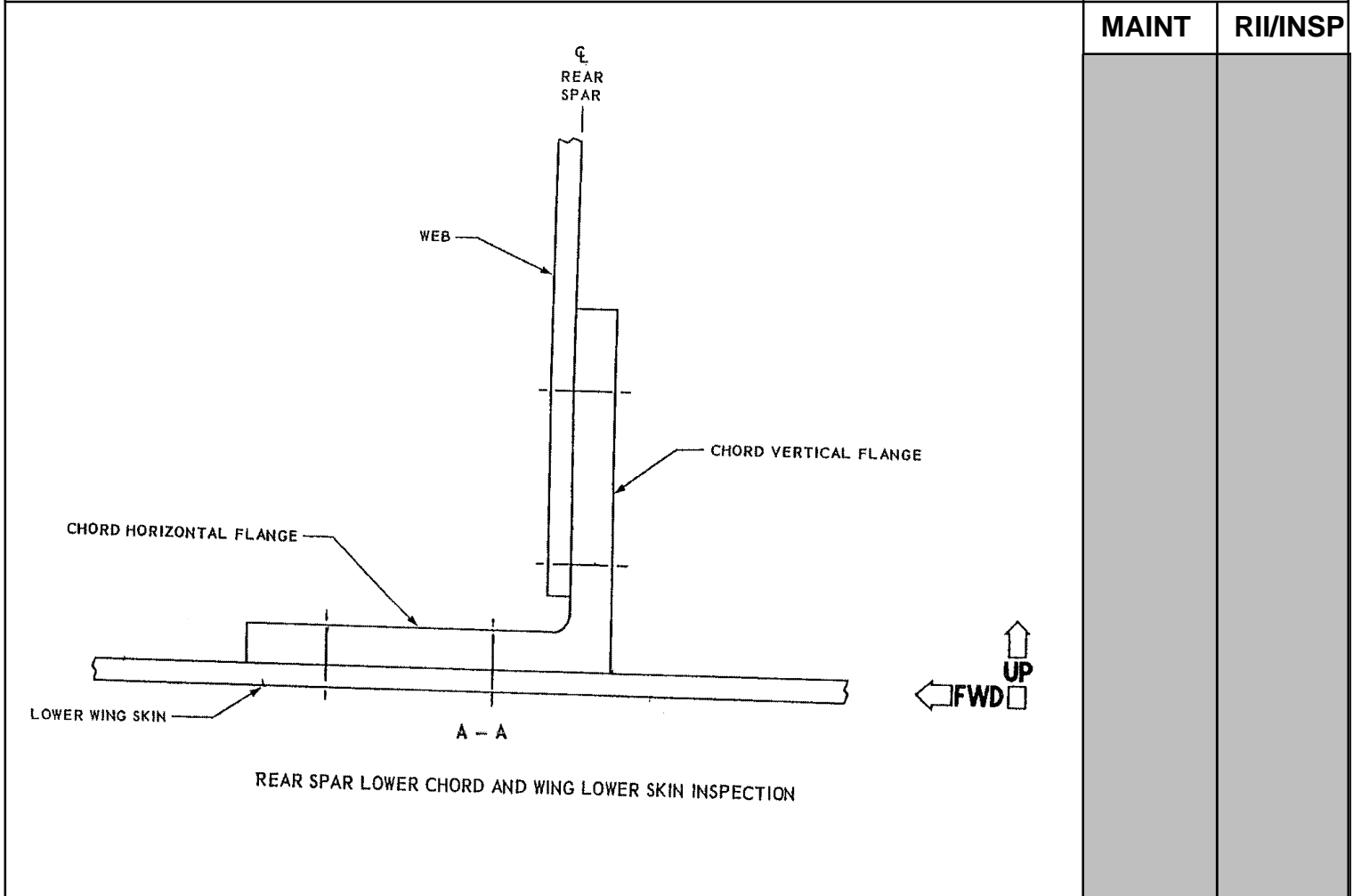

MAINT	RII/INSP

Nr.	Hardtime	Task	Spec.	Related Documents
3.		E4	INS	AD 85-12-01 R1 rev 5439 MMS-328 572080 02003 rev 15.07.05 SSID 57-A45-05/C2 rev P

**Check:** C1

**Zones:** 136, 673, 685

**Access:** 1324R

NRC YES  NO  IF YES, NUMBER(S): .....

**RH WING REAR SPAR LOWER CHORD**

**RH WING REAR SPAR LOWER CHORD, WEB TERMINAL FITTING / SPAR CHORD & WING LOWER SKIN BBL 70.50 TO WBL 59.24.**

Do an H.F.E.C. internal inspection of wing lower skin, chord splice & all areas where presence of secondary structure impaired external inspection.

Refer. DOC D6-48023, Part 6, 57-10-07, Fig 53

**RH WING REAR SPAR LOWER CHORD NDI INSPECTION**

<b>sabena</b> B707	Module: RH WING + FL CTR	A/C Reg :	Check :	 41F4000516 Page 6 of 7
	Oper. : RT-MP LC	Issuer : A59513	Cert.St.: 46928	
	Type : NDT INSP	Release Date: 22.11.2006		
Spec. : NDT INSP				

**RH WING REAR SPAR LOWER CHORD NDI INSPECTION**

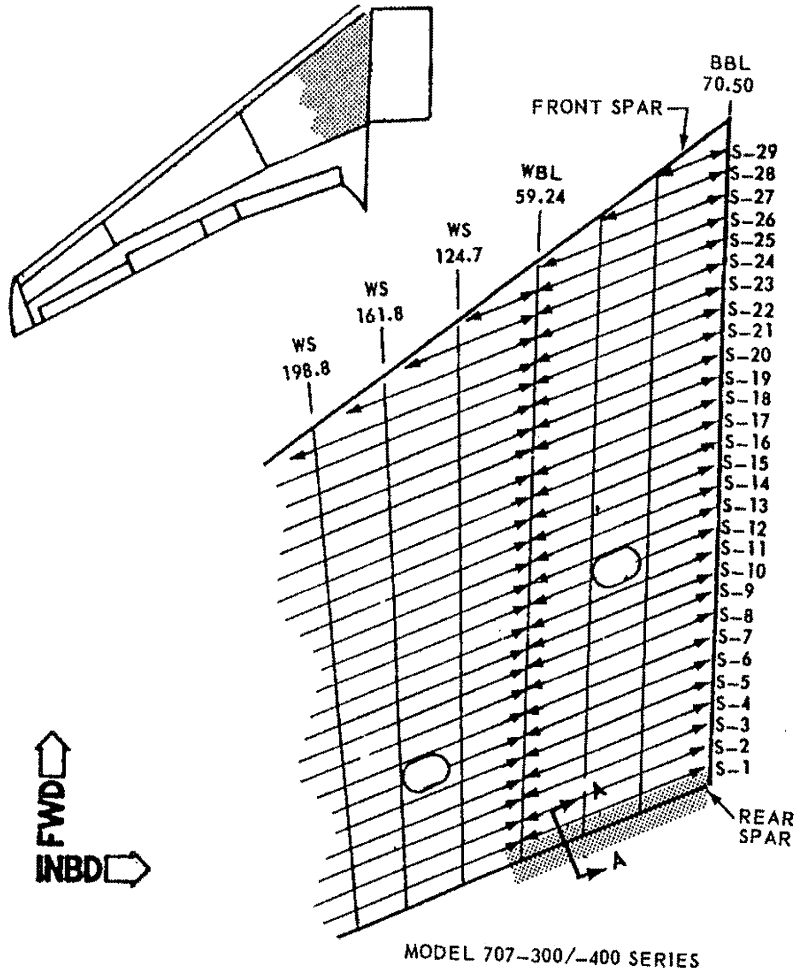

MODEL 707-300/-400 SERIES  
REAR SPAR LOWER CHORD AND WING LOWER SKIN INSPECTION  
BBL 70.50 THRU WBL 129.62/59.24

MAINT	RII/INSP

<b>sabena</b> B707	Module: RH WING + FL CTR	A/C Reg :	Check :	 <b>41F4000516</b>
	Oper. : RT-MP LC	Issuer : A59513	Cert.St.: 46928	
	Type : NDT INSP	Release Date: 22.11.2006	Page 7 of 7	

**RH WING REAR SPAR LOWER CHORD NDI INSPECTION**

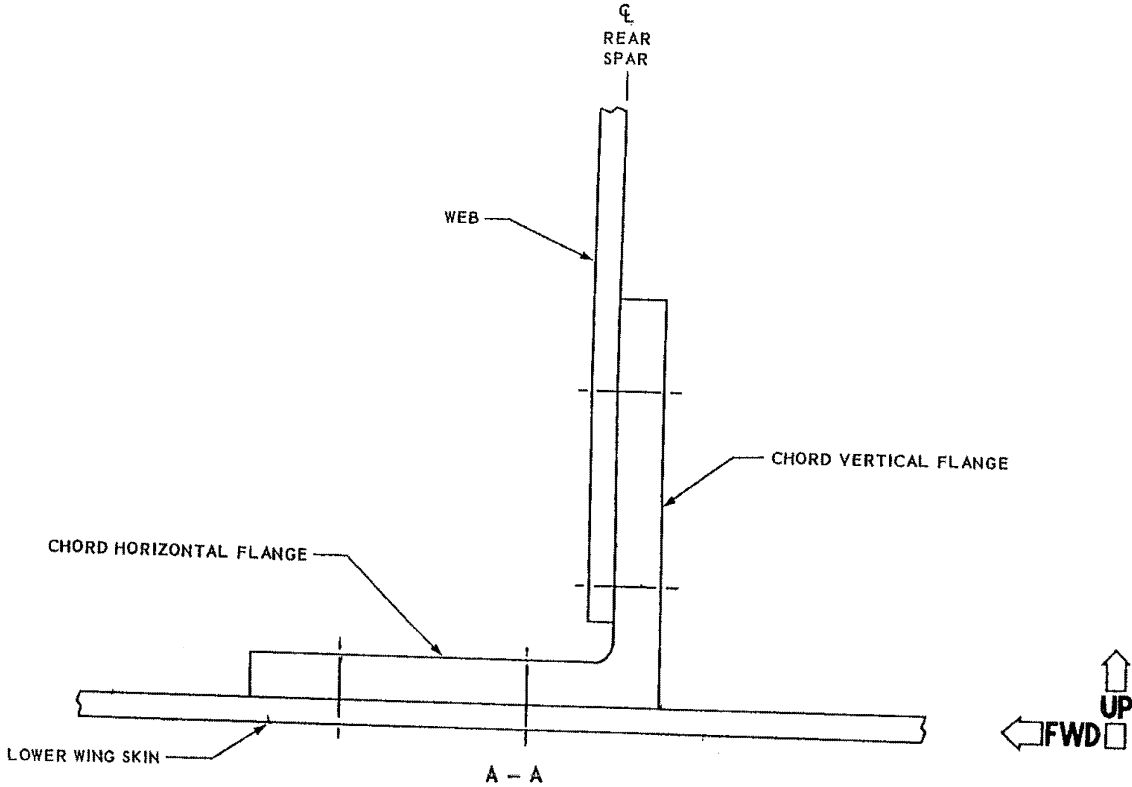

REAR SPAR LOWER CHORD AND WING LOWER SKIN INSPECTION

MAINT	RII/INSP

**RH WING REAR SPAR LOWER CHORD NDI INSPECTION**