



sabena [®] B707	Module: HOR STAB + FL CT	A/C Reg :	Check :	 61E0000502
	Oper. : RT-MP LC			
	Type : * ZONAL INSP*	Issuer : A59513	Cert.St.: 50516	Page 1 of 3
Spec. : MECHANIC	Release Date: 04.05.2011			

AD 94-10-06 rev . RH HOR STAB FRONT SPAR SPLICE & CHORD INSP

		MAINT	RII/INSP
Execution / Start Date:			
End Date:			

AD 94-10-06 rev . RH HOR STAB FRONT SPAR SPLICE & CHORD INSP

sabena B707	Module: HOR STAB + FL CT	A/C Reg :	Check :	 61E0000502
	Oper. : RT-MP LC	Issuer : A59513	Cert.St.: 50516	
	Type : * ZONAL INSP*	Release Date: 04.05.2011		
Spec. : MECHANIC				

AD 94-10-06 rev . RH HOR STAB FRONT SPAR SPLICE & CHORD INSP

					MAINT	RII/INSP
Nr.	Hardtime	Task	Spec.	Related Documents		
1.		E3 E4	MEC	AD 94-10-06 rev 8913 MMS-328 551140 01003 rev 15/06/09 SB 55-3145 rev .		
Check: C						
Zones: 392						
Access:						
<u>RH HORIZONTAL STABILIZER UPPER FRONT SPAR SPLICE & CHORD STA. 11.55 INSPECTION.</u>						
1. Visually inspect both the upper and lower front spar chord splice plate for corrosion and cracking. Typical cracks reported are shown in det. 1. The outboard leg of the splice is the only area easily accessible. The inboard leg can be viewed through an access opening in the stabilizer lower skin immediately aft of the inboard end of the front spar (3).						
2. Between st. 11.55 and the inboard end of the front spar, visually inspect for skin bulges around and between the fasteners attaching the skin to the upper and lower spar chord forward and aft flanges. Bulges are indicative of corrosion and laminar cracks in the flange (6).						
3. If no bulges are found, do a LOW FREQUENCY EDDY CURRENT inspection of the front spar upper chord fwd flange and the lower chord forward and aft flanges per Boeing NTM D6-48023 p6. sub 55-10-07 fig 8. The inspection will detect corrosion and cracks that have not developed enough to cause bulging (7).						
4. In addition to the foregoing inspections, inspect the raised portion of the chord between the fwd edge of the interspar skins and the aft edges of the leading edge of skin (9).						
5. Inspect for surface cracks at the fwd and aft edges, using a HIGH FREQUENCY EDDY CURRENT inspection surface probe per D6-48023 p6, sub 51-00-00 fig 4 and ultrasonically inspect for laminar cracks per D6-48023 p4, sub 57-10-07 fig 12 (9).						
6. Visually inspect the front surface and the exposed area of the aft surface of the vertical flange of the upper and lower chord for cracks and corrosion. Also check the spar web for bulges at and between the fasteners attaching the web to the vertical flanges (10).						
7. If no corrosion or cracking is found, or minor surface corrosion is cleaned up, apply a liberal coating of water inhibiting compound AV 30 to the plates. See structural repair manual subject 51-8-0.						

AD 94-10-06 rev . RH HOR STAB FRONT SPAR SPLICE & CHORD INSP

sabena B707	Module: HOR STAB + FL CT	A/C Reg :	Check :	
	Oper. : RT-MP LC			
	Type : * ZONAL INSP*	Issuer : A59513	Cert.St.: 50516	61E0000502
	Spec. : MECHANIC	Release Date: 04.05.2011		Page 3 of 3

AD 94-10-06 rev .

RH HOR STAB FRONT SPAR SPLICE & CHORD INSP

MAINT RII/INSP

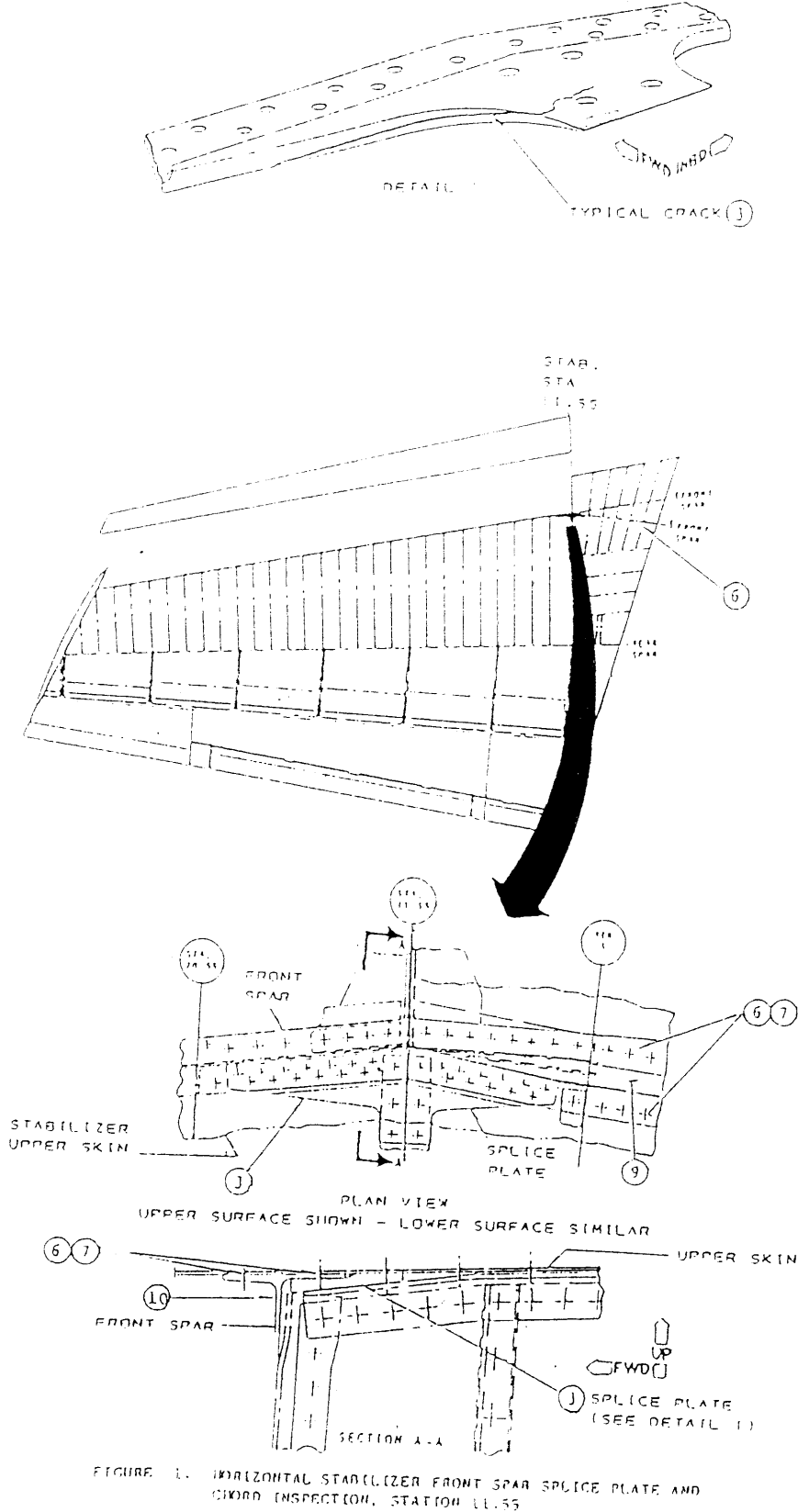

AD 94-10-06 rev .

RH HOR STAB FRONT SPAR SPLICE & CHORD INSP