



<b>sabena</b> <sup>®</sup> <b>B707</b>	Module: HOR STAB + FL CT	A/C Reg :	Check :	 <b>61F2000501</b>
	Oper. : RT-MP LC	Issuer : A43710	Cert.St.: 24828	
	Type : MEC-INSP	Release Date: 11.10.2001		Page 1 of 3
Spec. : MECHANIC				

AD 91-07-07 rev 6493

**STAB CENTER SECT INSP**

Execution / Start Date:	
End Date:	

<b>MAINT</b>	<b>RII/INSP</b>
--------------	-----------------

<b>sabena</b> <b>B707</b>	Module: HOR STAB + FL CT	A/C Reg :	Check :	
	Oper. : RT-MP LC			
	Type : MEC-INSP	Issuer : A43710	Cert.St.: 24828	<b>61F2000501</b>
Spec. : MECHANIC	Release Date: 11.10.2001		<b>Page 2 of 3</b>	

AD 91-07-07 rev 6493                      STAB CENTER SECT INSP

					MAINT	RII/INSP
Nr.	Hardtime	Task	Spec.	Related Documents		
1.		E3 E4 S	MEC	AD 91-07-07 rev 6493 AD 92-04-01 rev 8170 MMS-328 551440 01000 rev 15/05/01 SB 55-2959 rev 4. SB 55-3067 rev . SB 55A3482 rev 1.		
<b>Check: C</b>						
<b>Zones:</b>						
<b>Access: 1185 L</b>						

**OUTBOARD SECTION FRONT SPAR UPPER CLEVIS UPPER LUG OF STABILIZER CENTER SECTION INSPECTION.**

1. Close visual inspection of the safety strap and clevis lugs for cracks, special attention should be given to the FWD inboard and AFT outboard areas of the lugs.
2. If no cracks are found: Ultrasonic inspection (DOC. D6-48023 p4, subj 55-10-07 fig 1 & 2) of the lugs.
3. After inspection apply BMS 3-23.

<b>sabena</b> B707	Module: HOR STAB + FL CT	A/C Reg :	Check :	 <b>61F2000501</b>
	Oper. : RT-MP LC	Issuer : A43710	Cert.St.: 24828	
	Type : MEC-INSP	Release Date: 11.10.2001	<b>Page 3 of 3</b>	
Spec. : MECHANIC				

AD 91-07-07 rev 6493

STAB CENTER SECT INSP

MAINT	RII/INSP
-------	----------

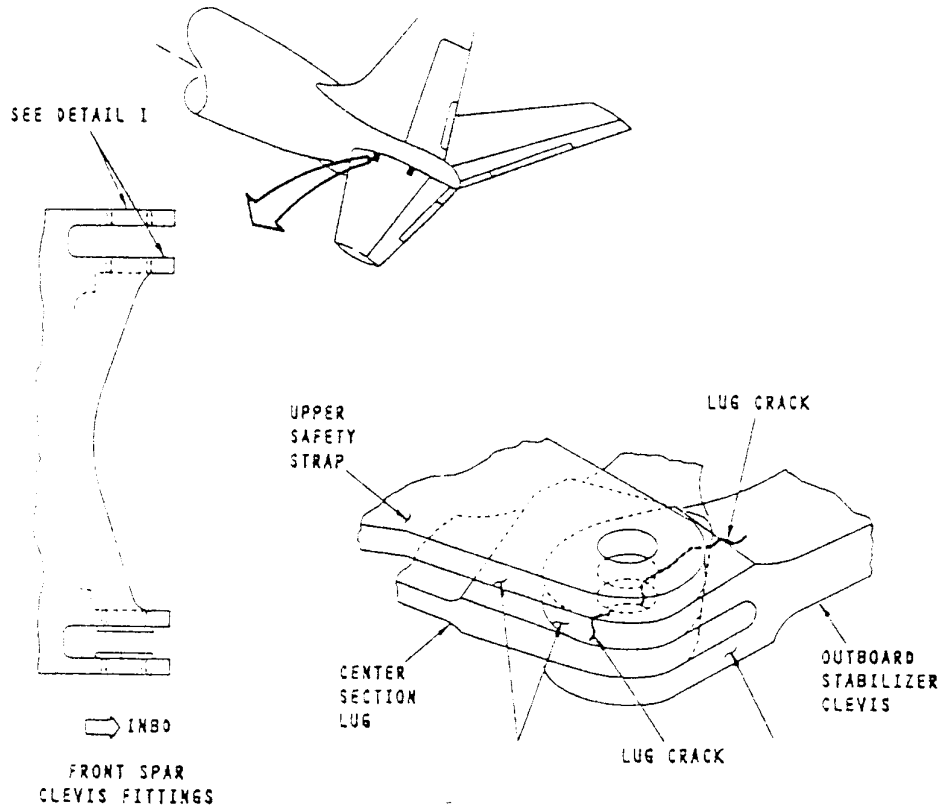

FIGURE 3. UPPER CLEVIS UPPER LUG INSPECTION