



sabena [®] B707	Module: HOR STAB + FL CT	A/C Reg :	Check :	 61F2000505
	Oper. : RT-MP LC			
	Type : MEC-INSP	Issuer : A59513	Cert.St.: 50516	
Spec. : MECHANIC	Release Date: 03.05.2011		Page 1 of 2	

AD 85-12-01 rev . **HOR STAB R/S UP LUG INSP**

		MAINT	RII/INSP
Execution / Start Date:			
End Date:			

AD 85-12-01 rev . **HOR STAB R/S UP LUG INSP**

sabena B707	Module: HOR STAB + FL CT	A/C Reg :	Check :	 61F2000505 Page 2 of 2
	Oper. : RT-MP LC	Issuer : A59513	Cert.St.: 50516	
	Type : MEC-INSP	Release Date: 03.05.2011		
Spec. : MECHANIC				

AD 85-12-01 rev . **HOR STAB R/S UP LUG INSP**

					MAINT	RII/INSP	
Nr.	Hardtime	Task	Spec.	Related Documents			
1.		E3	MEC	AD 85-12-01 R1 rev 5439 MMS-328 533580 04001 rev 30.10.08 SB 55-3243 rev . SB 55-3331 rev . SB A3516 rev 0 SSID 55-A45-01/A rev N.			
Check: C							
Zones: 137							
Access: 1185 L							
NRC YES <input type="radio"/> NO <input type="radio"/>		IF YES, NUMBER(S):					

CONDITION: HORIZONTAL STABILIZER L.E IN DOWN POSITION.

HORIZONTAL STABILIZER REAR SPAR UPPER LUG INSPECTION.

1. Close visual inspection of all exposed surfaces of the fail-safe strap for cracks.
2. Apply BMS 3-23 on center section upper rear spar lugs.

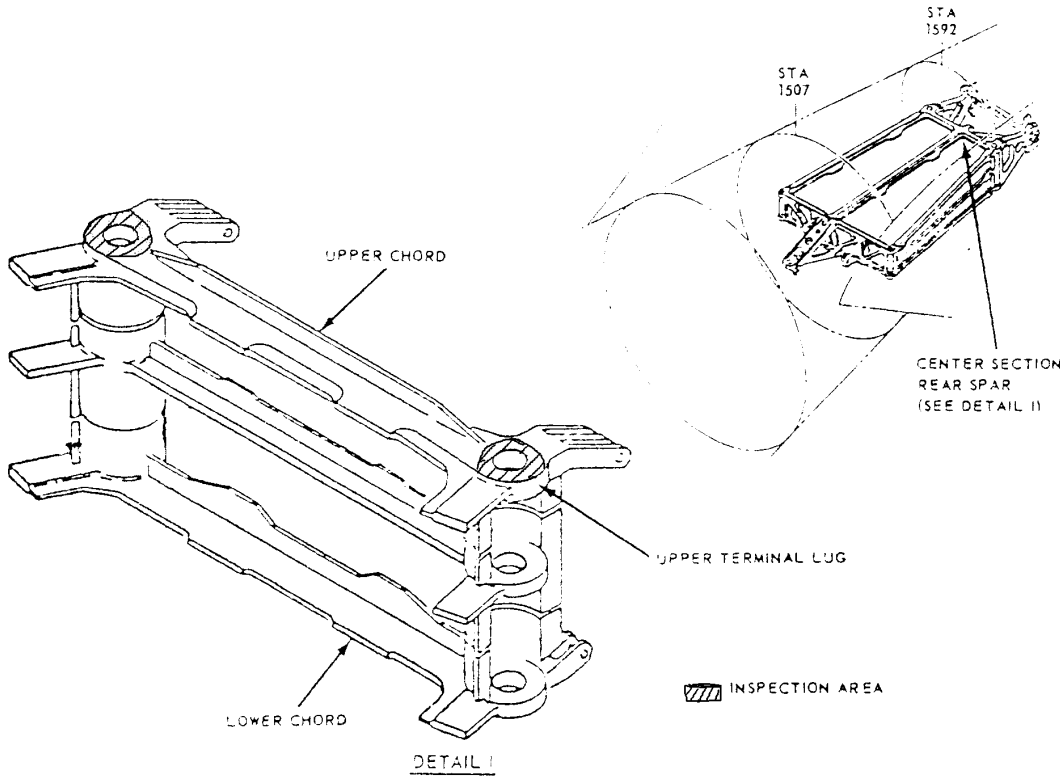

HORIZONTAL STABILIZER CENTER SECTION REAR SPAR LUG INSPECTION

AD 85-12-01 rev . **HOR STAB R/S UP LUG INSP**