



sabena [®] B707	Module: HOR STAB + FL CT	A/C Reg :	Check :	 61F400004
	Oper. : RT-MP LC			
	Type : NDT INSP	Issuer : A59513	Cert.St.: 50516	Page 1 of 3
Spec. : NDT INSP	Release Date: 04.05.2011			

LH HOR. STAB. CHORD NDT INSPECTION

Execution / Start Date:	
End Date:	

MAINT	RII/INSP

sabena B707	Module: HOR STAB + FL CT	A/C Reg :	Check :	 61F400004 Page 2 of 3
	Oper. : RT-MP LC	Issuer : A59513	Cert.St.: 50516	
	Type : NDT INSP	Release Date: 04.05.2011		
	Spec. : NDT INSP			

LH HOR. STAB. CHORD NDT INSPECTION

					MAINT	RII/INSP	
Nr.	Hardtime	Task	Spec.	Related Documents			
1.		E4	NDT	MMS-328 551150 01002 rev 25/11/08 SB 707-55-A3515 rev 19/12/2007			
Check: B							
Zones:							
Access:							
NRC YES <input type="radio"/> NO <input type="radio"/>		IF YES, NUMBER(S):					

Special Detailed Inspection of the Upper Chord on the inboard side of the rear spar of the Left Horizontal Stabilizer (STA 13.179 TO 92.55).

Inspect for cracks in the space between the inspar skin & the forward edge of the exposed upper face of the upper chord of the rear spar. Inspect from the side of the body outboard towards Stabilizer Station 92.55.

Refer to 707, 720 NDT, Part 6, 55-10-07, Figure 2, as an accepted procedure.

Inspects for cracks in the space between the trailing edge skin & the aft edge of the exposed upper surface of the upper chord of the rear spar. Inspect from the side of the body outboard to Stabilizer Station 92.55.

Refer to 707, 720 NDT, Part 6, 55-10-07, Figure 2, as an accepted procedure.

Note : If a crack is found DO NOT perform repair per SB A3313. Contact Engineering Department (ESEC) for instructions.

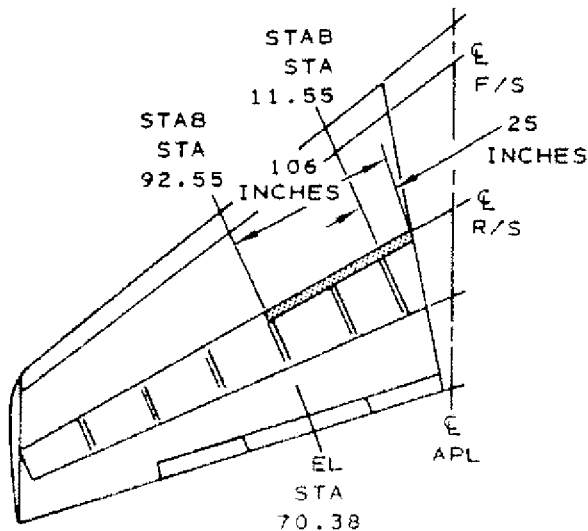

 INSPECTION AND MODIFICATION AREAS

PLAN VIEW HOR. STAB

LH HOR. STAB. CHORD NDT INSPECTION

LH HOR. STAB. CHORD NDT INSPECTION

MAINT RII/INSP

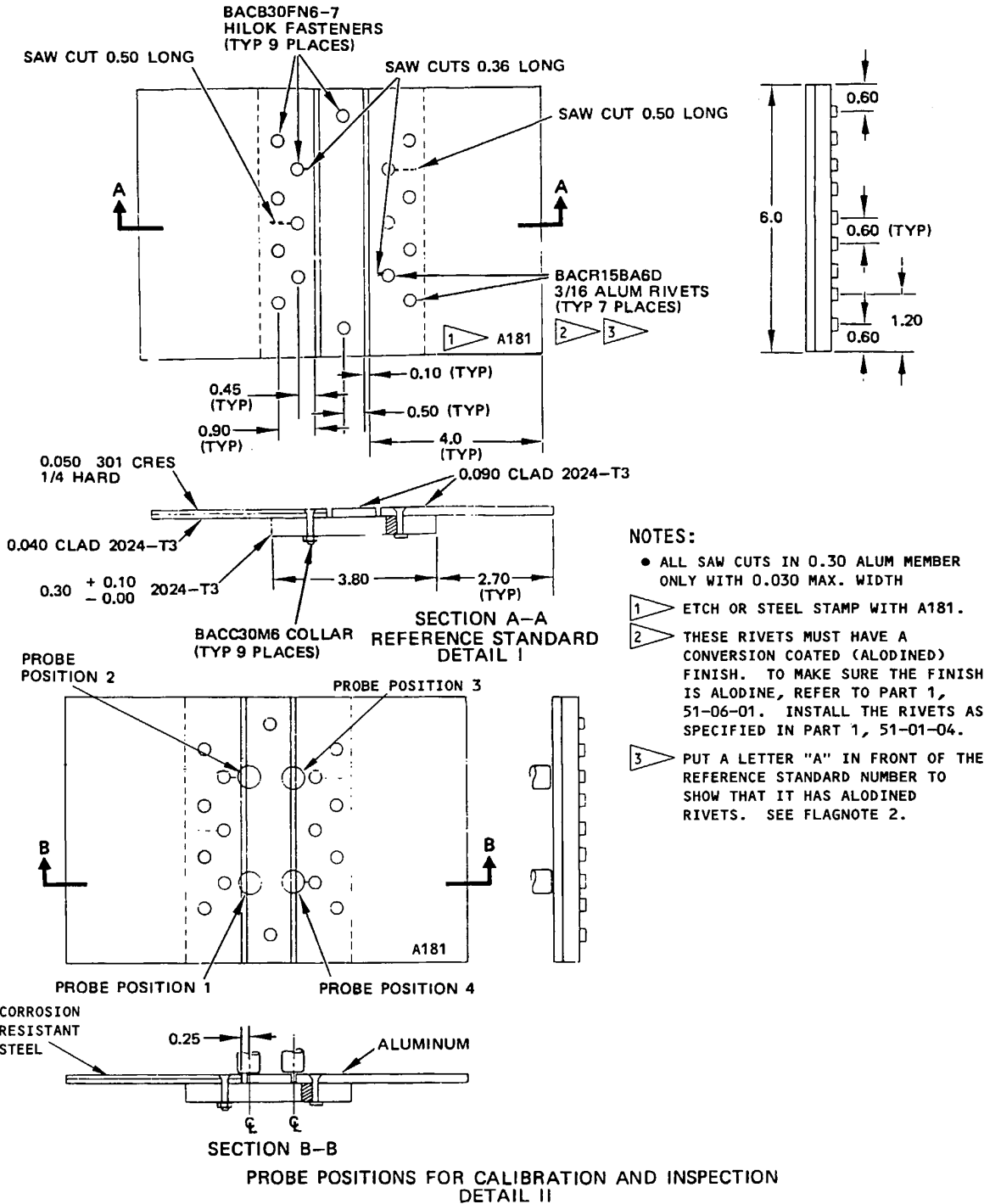

NOTES:

- ALL SAW CUTS IN 0.30 ALUM MEMBER ONLY WITH 0.030 MAX. WIDTH
- 1 ▽ ETCH OR STEEL STAMP WITH A181.
- 2 ▽ THESE RIVETS MUST HAVE A CONVERSION COATED (ALODINED) FINISH. TO MAKE SURE THE FINISH IS ALODINE, REFER TO PART 1, 51-06-01. INSTALL THE RIVETS AS SPECIFIED IN PART 1, 51-01-04.
- 3 ▽ PUT A LETTER "A" IN FRONT OF THE REFERENCE STANDARD NUMBER TO SHOW THAT IT HAS ALODINED RIVETS. SEE FLAGNOTE 2.