



<b>sabena</b> <sup>®</sup> <b>B707</b>	Module: HOR STAB + FL CT	A/C Reg :	Check :	 <b>61F4000012</b>
	Oper. : RT-MP LC			
	Type : NDT INSP	Issuer : A59513	Cert.St.: 50516	<b>Page 1 of 4</b>
Spec. : NDT INSP	Release Date: 11.05.2011			

**LH STAB REAR SPAR UPPER CHORD INSPECTION**

Execution / Start Date:	
End Date:	

MAINT	RII/INSP

<b>sabena</b> B707	Module: HOR STAB + FL CT	A/C Reg :	Check :	
	Oper. : RT-MP LC			
	Type : NDT INSP	Issuer : A59513	Cert.St.: 50516	61F4000012
Spec. : NDT INSP	Release Date: 11.05.2011		Page 2 of 4	

**LH STAB REAR SPAR UPPER CHORD INSPECTION**

					MAINT	RII/INSP
Nr.	Hardtime	Task	Spec.	Related Documents		
1.		E4	NDT	MMS-328 551190 01002 rev 01/11/10		
Check: B						
Zones: 391						
Access:						
NRC YES <input type="radio"/> NO <input type="radio"/>		IF YES, NUMBER(S): .....				

**PERFORM HFEC INSPECTION ON LH STABILIZER REAR SPAR UPPER CHORD AFT FLANGE.**

- Clean sealant before inspection.
- Perform HFEC surface inspection on LH stabilizer rear spar upper chord aft flange around the periphery of the repair strap (between SSTA 101.55 & SSTA 128.55), including flange free edge.  
This inspection was requested by Boeing due to crack repair in this area.  
See NCR CG-00063.
- Reapply sealant after inspection.

<b>sabena</b> B707	Module: HOR STAB + FL CT	A/C Reg :	Check :	 61F400012 Page 3 of 4
	Oper. : RT-MP LC	Issuer : A59513	Cert.St.: 50516	
	Type : NDT INSP	Release Date: 11.05.2011		
	Spec. : NDT INSP			

**LH STAB REAR SPAR UPPER CHORD INSPECTION**

MAINT      RII/INSP

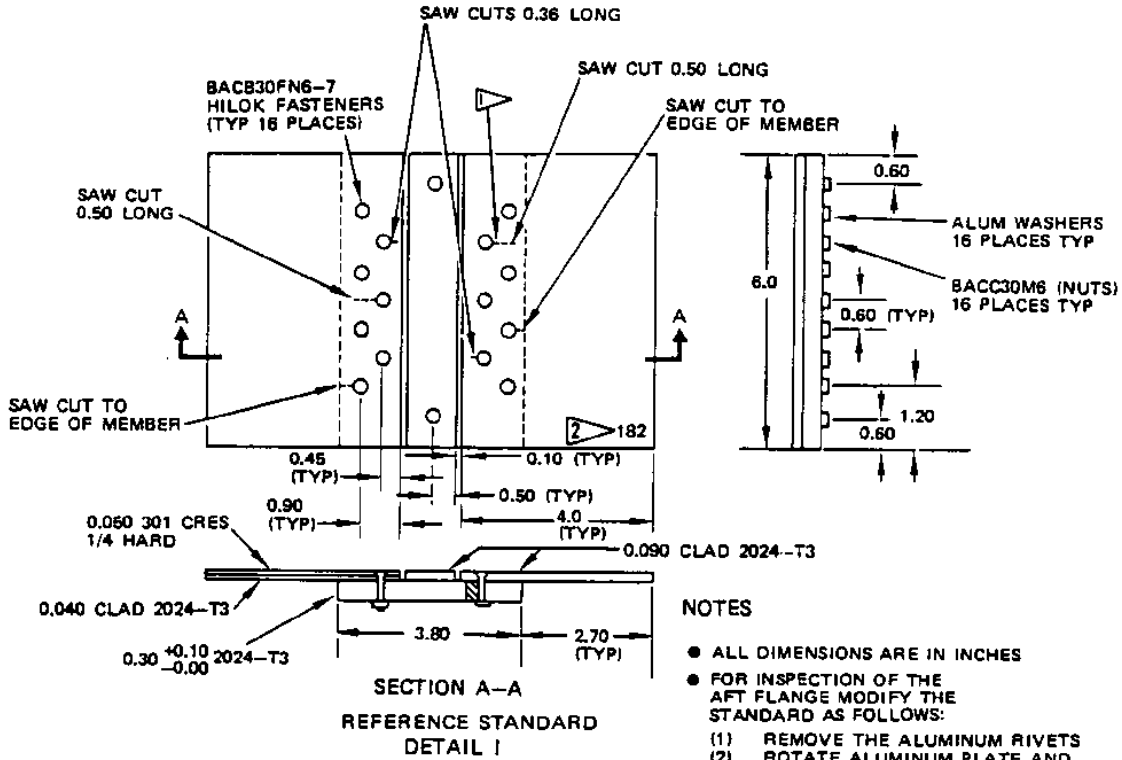

**NOTES**

- ALL DIMENSIONS ARE IN INCHES
- FOR INSPECTION OF THE AFT FLANGE MODIFY THE STANDARD AS FOLLOWS:
  - (1) REMOVE THE ALUMINUM RIVETS
  - (2) ROTATE ALUMINUM PLATE AND DRILL NEW HOLES TO MATCH EXISTING HOLES IN LOWER PLATE
  - (3) COUNTERSINK HOLES TO SUIT HILOK FASTENERS
  - (4) ASSEMBLE USING HILOK FASTENERS

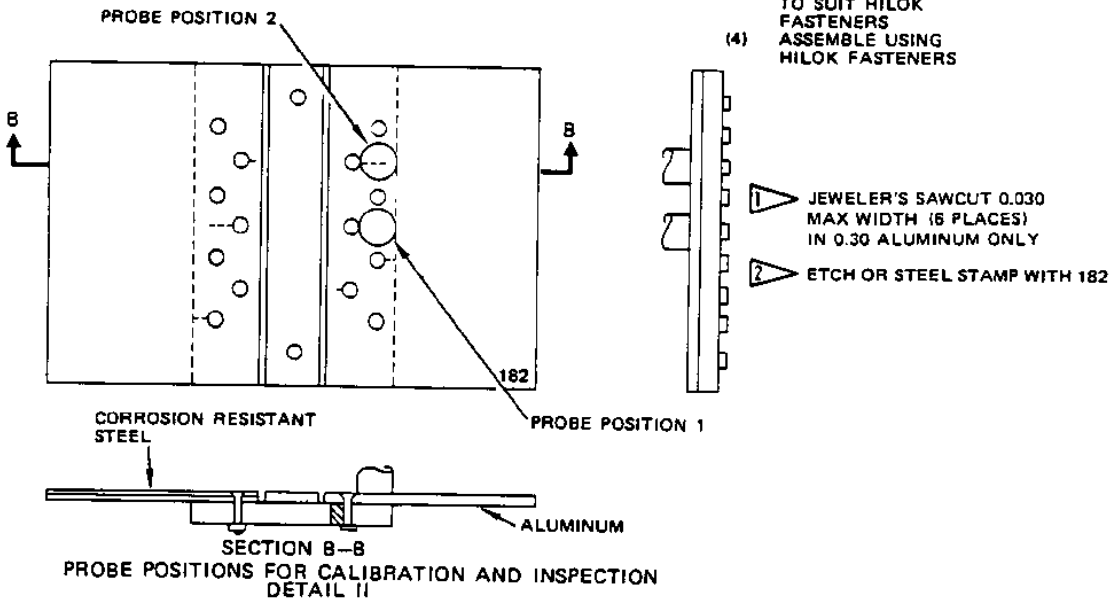

Horizontal Stabilizer Upper and Lower Forward and Rear Spar Chord Flanges  
Figure 8 (Sheet 4) Part 6

<b>sabena</b> B707	Module: HOR STAB + FL CT	A/C Reg :	Check :	
	Oper. : RT-MP LC			
	Type : NDT INSP	Issuer : A59513	Cert.St.: 50516	61F400012
	Spec. : NDT INSP	Release Date: 11.05.2011		Page 4 of 4

LH STAB REAR SPAR UPPER CHORD INSPECTION

MAINT	RII/INSP
-------	----------

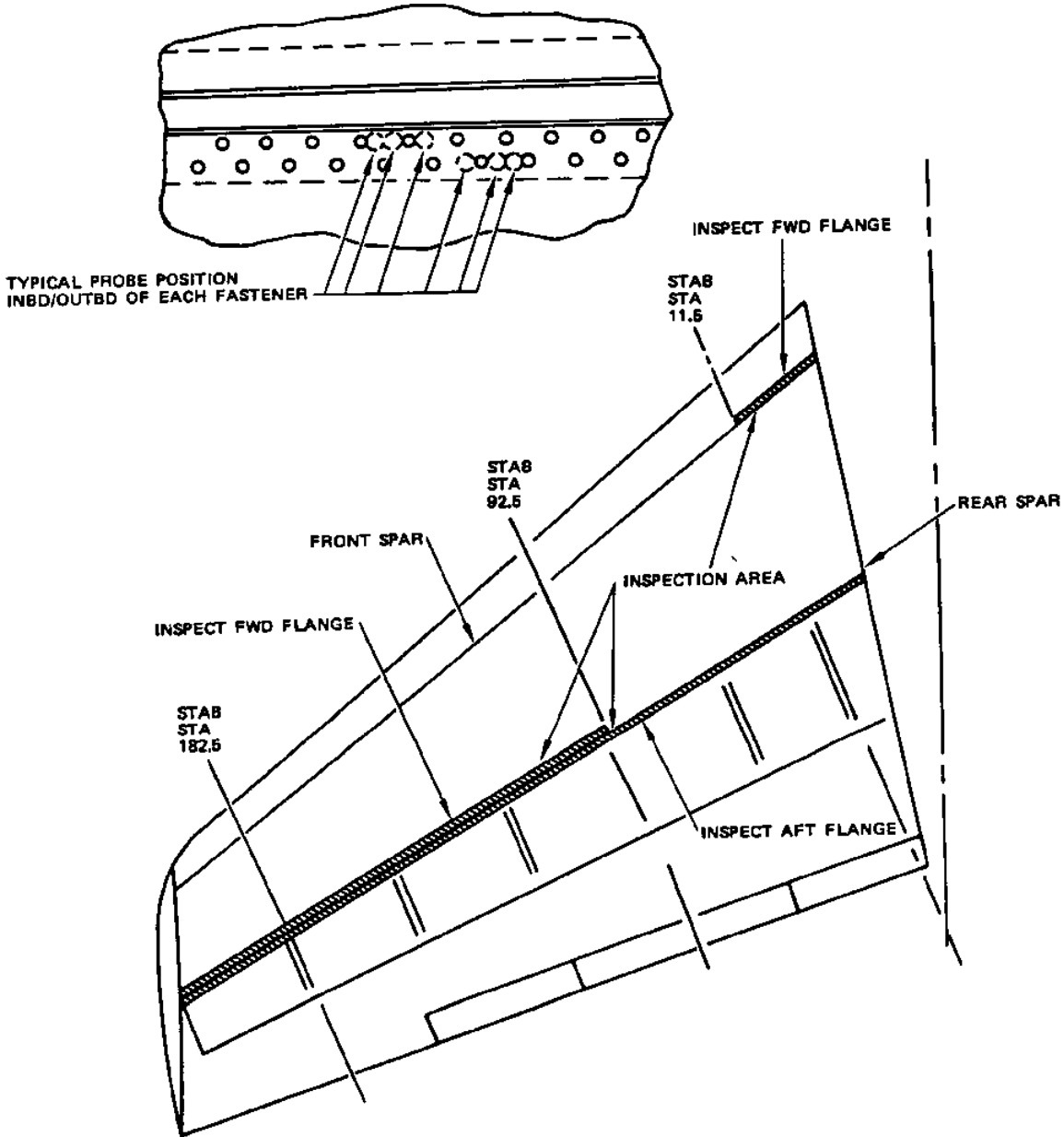

DETAIL III INSPECTION AREA

Horizontal Stabilizer Upper and Lower Forward and Rear Spar Chord Flanges  
Figure 8 (Sheet 5)

LH STAB REAR SPAR UPPER CHORD INSPECTION