

sabena B707	Module: HOR STAB + FL CT	A/C Reg :	Check :	
	Oper. : RT-MP LC			
	Type : *LUBE*	Issuer : A43710	Cert.St.: 24828	6110000502
Spec. : MECHANIC	Release Date: 16.10.2001		Page 1 of 3	

AD 64-09-02 rev . LH ELEV BAL PAN LUB

			MAINT	RII/INSP
Execution / Start Date:				
End Date:				

Pos	Mat. Type	P/N	IDN	Description	Qty	Unit
1	FL & CH	MIL-G-23827		GREASE	0.00	

--	--	--	--	--	--	--

AD 64-09-02 rev . LH ELEV BAL PAN LUB

sabena B707	Module: HOR STAB + FL CT	A/C Reg :	Check :	 6110000502
	Oper. : RT-MP LC	Issuer : A43710	Cert.St.: 24828	
	Type : *LUBE*	Spec. : MECHANIC	Release Date: 16.10.2001	Page 2 of 3

AD 64-09-02 rev . LH ELEV BAL PAN LUB

					MAINT	RII/INSP
Nr.	Hardtime	Task	Spec.	Related Documents		
1.		S	MEC	AD 64-09-02 rev 717 MMS-328 273008 00101 rev 15/05/01 SB 27-1865 rev .		
Check: C1 Zones: 393 Access:						

LH ELEVATOR BALANCE PANEL AND PIANO HINGES LUBRICATION.

(Mark with 'X' at each lube location)

NOTE: Remove excess of grease & clean contamination areas in the immediate vicinity.

Lubricate the LH elevator balance panel and piano hinges.

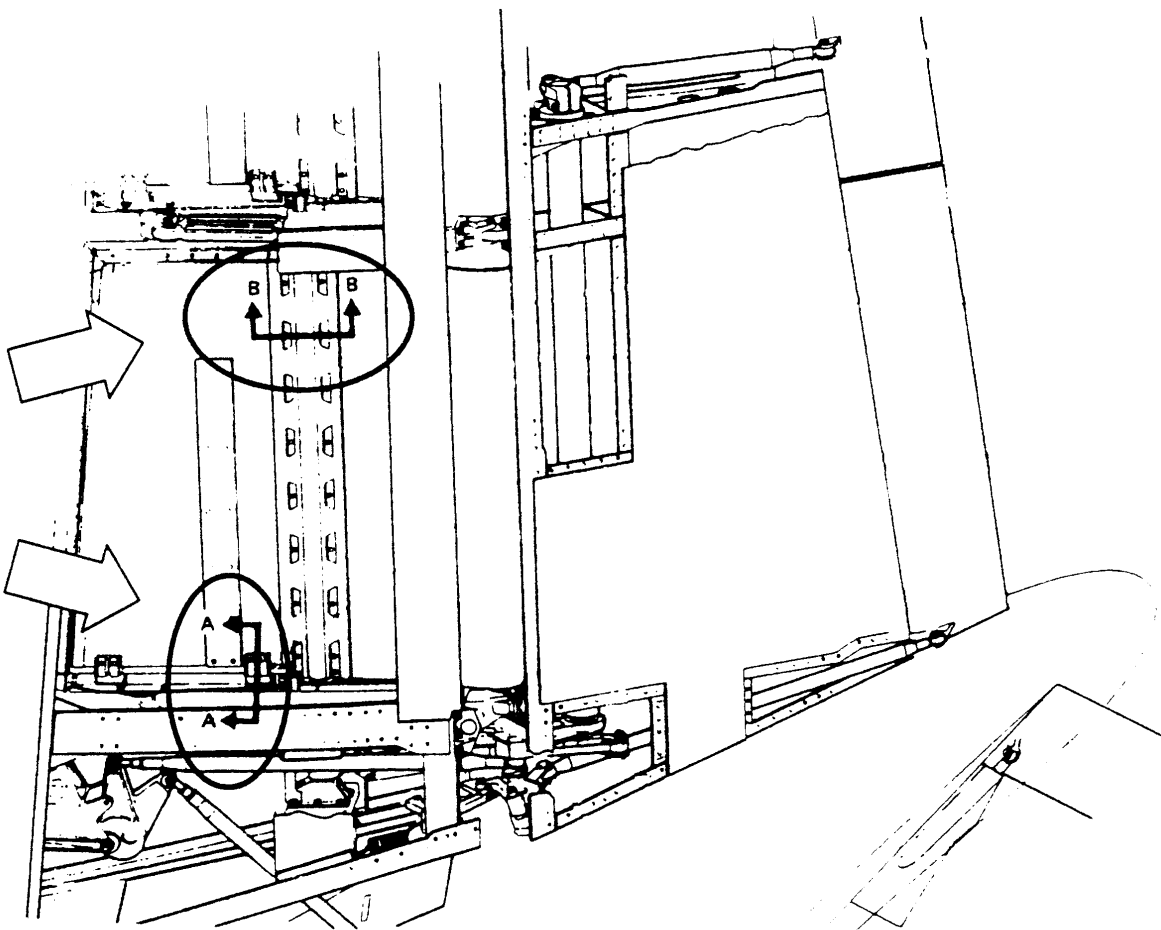

sabena B707	Module: HOR STAB + FL CT	A/C Reg :	Check :	 6110000502
	Oper. : RT-MP LC	Issuer : A43710	Cert.St.: 24828	
	Type : *LUBE*	Release Date: 16.10.2001	Page 3 of 3	
Spec. : MECHANIC				

AD 64-09-02 rev . LH ELEV BAL PAN LUB

MAINT RII/INSP

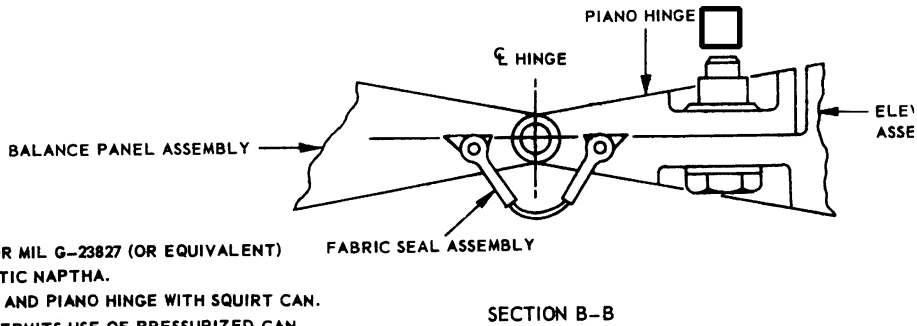
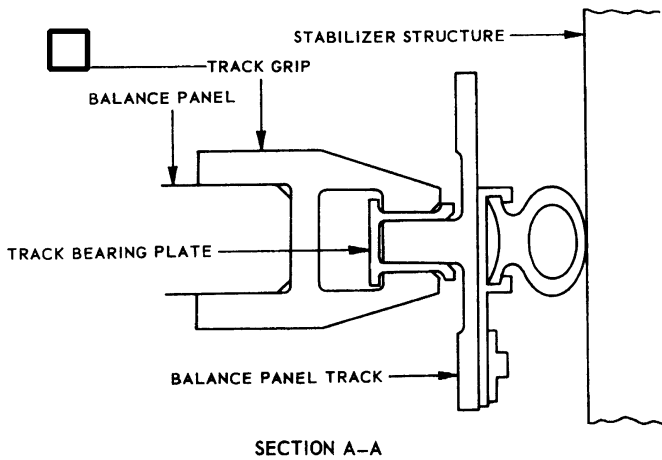

NOTE 1:
MIX GREASE BMS 3-24 OR MIL G-23827 (OR EQUIVALENT)
WITH M.E.K. OR ALIPHATIC NAPHTHA.
APPLY TO TRACK GRIP AND PIANO HINGE WITH SQUIRT CAN.
ALTERNATE METHOD PERMITS USE OF PRESSURIZED CAN
FILLED WITH GREASE MIL G-21164 (OR EQUIVALENT).

▶ LUBRICATION INTERVAL NOT TO EXCEED 1,200 FLIGHT HOURS
PER FAA AIRWORTHINESS DIRECTIVE 64-09-02