



sabena [®] B707	Module: MAIN CARGO CMPT	A/C Reg :	Check :	 A1F4000503
	Oper. : RT-MP LC			
	Type : NDT INSP	Issuer : A59513	Cert.St.: 46928	Page 1 of 4
Spec. : NDT INSP	Release Date: 15.06.2006			

AD 85-12-01 MAIN CARGO DOOR CAM SPT FTG HFEC INSP

		MAINT	RII/INSP
Execution / Start Date:			
End Date:			

AD 85-12-01 MAIN CARGO DOOR CAM SPT FTG HFEC INSP

sabena B707	Module: MAIN CARGO CMPT	A/C Reg :	Check :	 A1F4000503 Page 2 of 4
	Oper. : RT-MP LC			
	Type : NDT INSP	Issuer : A59513	Cert.St.: 46928	
	Spec. : NDT INSP	Release Date: 15.06.2006		

AD 85-12-01 MAIN CARGO DOOR CAM SPT FTG HFEC INSP

					MAINT	RII/INSP
Nr.	Hardtime	Task	Spec.	Related Documents		
1.		E4	NDT	AD 85-12-01 rev 5439 MMS-328 523280 02000 rev 15.07.05 SB 52A3387 rev . SSID 52-A45-03/A rev .		
Check: C						
Zones: 249						
Access:						
NRC YES <input type="radio"/> NO <input type="radio"/>		IF YES, NUMBER(S):				

MAIN CARGO DOOR CAM SUPPORT FITTING INSP.

Clean the inspection area.
 Inspect cam support fitting assies (8 places) for cracks in area around fitting flanged bushing & in fitting lower curved flange by using a HIGH FREQUENCY EDDY CURRENT inspection per D6-48023 p6, SUB 51-00-00 FIG. 4. Pay particular attention to area of lube fitting.

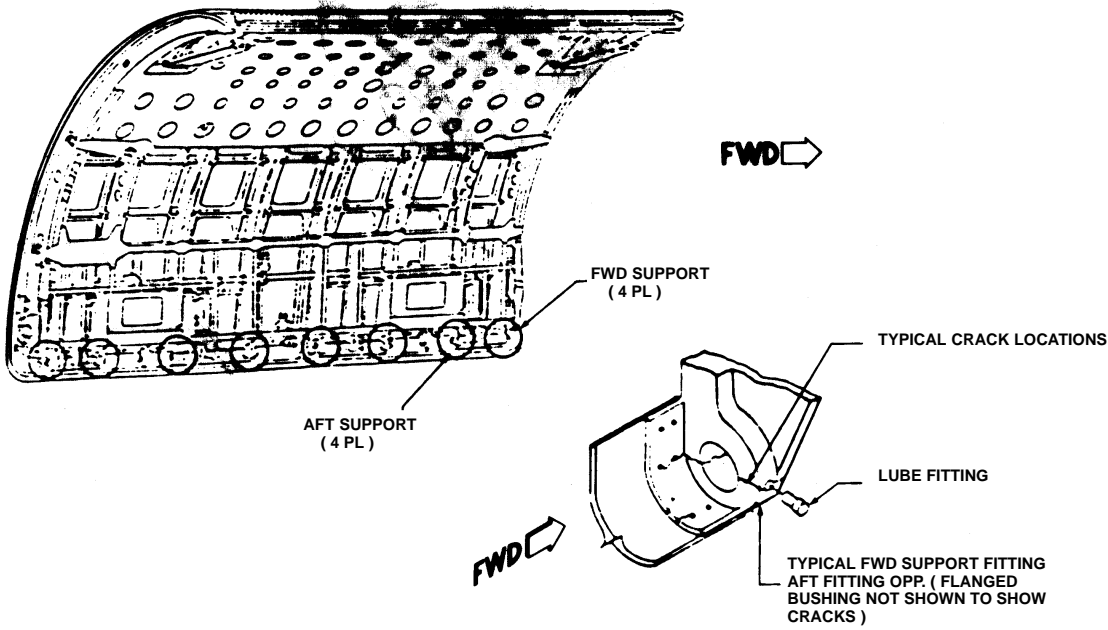

**UPPER DECK MAIN CARGO DOOR
CAM SUPPORT FITTING INSPECTION**

sabena B707	Module: MAIN CARGO CMPT	A/C Reg :	Check :	 A1F4000503 Page 3 of 4
	Oper. : RT-MP LC	Issuer : A59513	Cert.St.: 46928	
	Type : NDT INSP	Release Date: 15.06.2006		
Spec. : NDT INSP				

AD 85-12-01 MAIN CARGO DOOR CAM SPT FTG HFEC INSP

					MAINT	RII/INSP
Nr.	Hardtime	Task	Spec.	Related Documents		
2.	23236 CYC	E4	INS	AD 85-12-01 R1 rev 5439 MMS-328 523280 02000 rev 15.07.05 SB 52A3387 rev . SSID 52-A45-03/A rev .		
Check:						
Zones: 249						
Access:						
NRC YES <input type="radio"/> NO <input type="radio"/>		IF YES, NUMBER(S):				

MAIN CARGO DOOR CAM SUPPORT FITTING INSP.

Clean the inspection area.

Inspect cam support fitting assies (8 places) for cracks in area around fitting flanged bushing & in fitting lower curved flange by using a HIGH FREQUENCY EDDY CURRENT inspection per D6-48023 p6, SUB 51-00-00 FIG. 4. Pay particular attention to area of lube fitting.

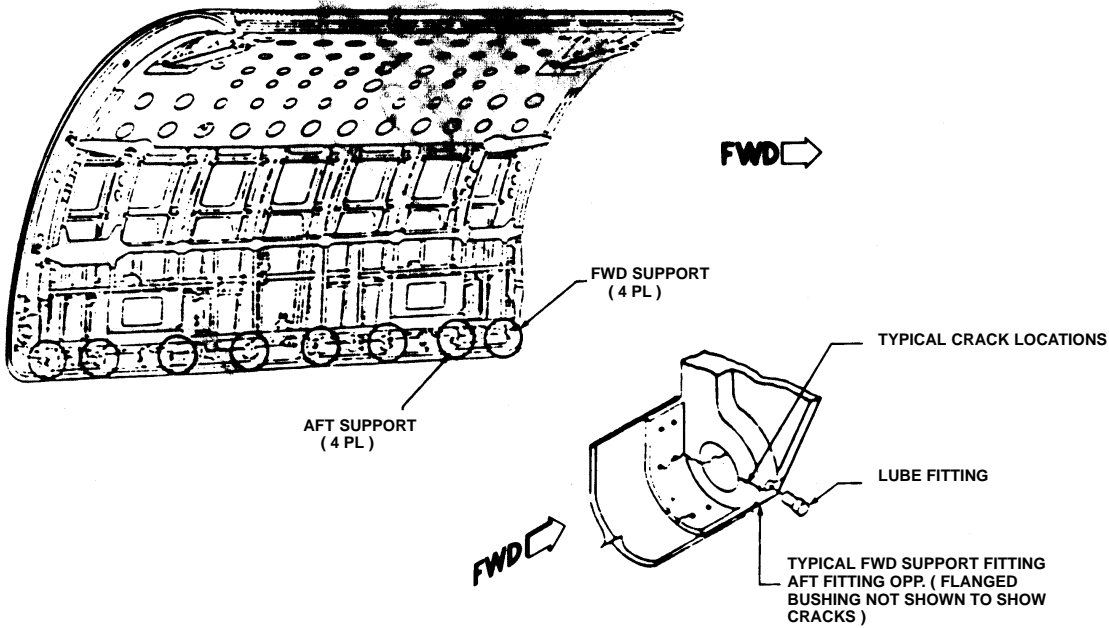

**UPPER DECK MAIN CARGO DOOR
CAM SUPPORT FITTING INSPECTION**

sabena B707	Module: MAIN CARGO CMPT	A/C Reg :	Check :	 A1F4000503 Page 4 of 4
	Oper. : RT-MP LC	Issuer : A59513	Cert.St.: 46928	
	Type : NDT INSP	Release Date: 15.06.2006		
Spec. : NDT INSP				

AD 85-12-01 MAIN CARGO DOOR CAM SPT FTG HFEC INSP

					MAINT	RII/INSP	
Nr.	Hardtime	Task	Spec.	Related Documents			
3.	23137 CYC	E4	INS	AD 85-12-01 R1 rev 5439 MMS-328 523280 02000 rev 15.07.05 SB 52A3387 rev . SSID 52-A45-03/A rev .			
Check:							
Zones: 249							
Access:							
NRC YES <input type="radio"/> NO <input type="radio"/>		IF YES, NUMBER(S):					

MAIN CARGO DOOR CAM SUPPORT FITTING INSPECTION.

Clean the inspection area.

Inspect cam support fitting assies (8 places) for cracks in area around fitting flanged bushing & in fitting lower curved flange by using a HIGH FREQUENCY EDDY CURRENT inspection per D6-48023 p6, SUB 51-00-00 FIG. 4. Pay particular attention to area of lube fitting.

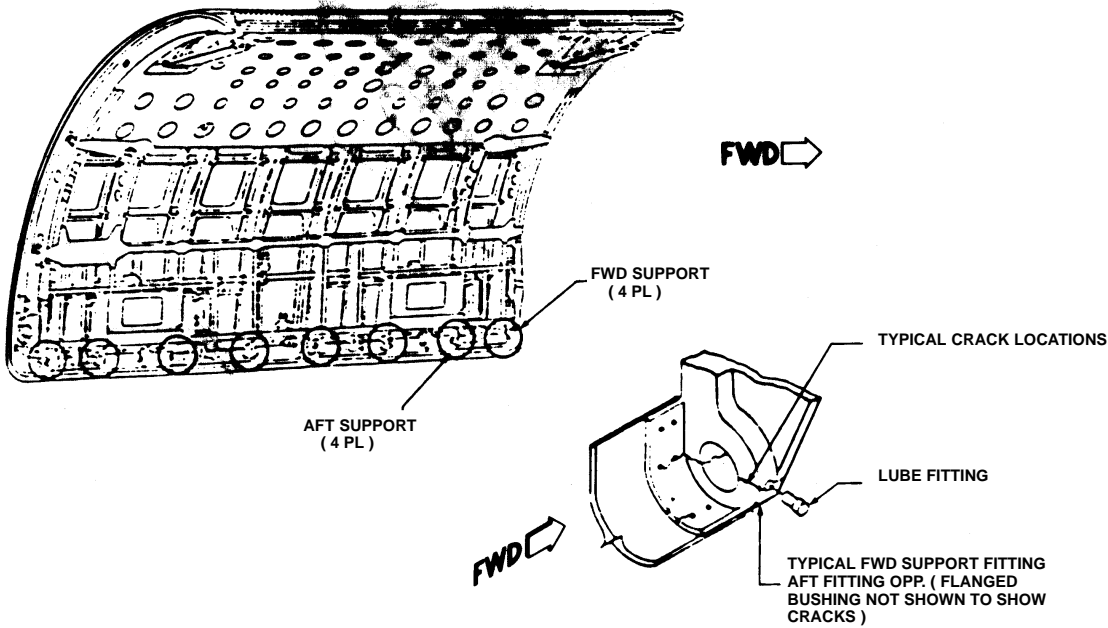

**UPPER DECK MAIN CARGO DOOR
CAM SUPPORT FITTING INSPECTION**