

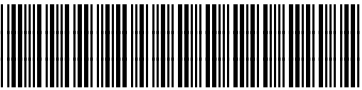

sabena [®] B707	Module: E&E + LWR NOSE C	A/C Reg :	Check :	 D1F1000505
	Oper. : RT-MP LC			
	Type : REI-INSP	Issuer : A43710	Cert.St.: 24828	
Spec. : ELECTRICIAN	Release Date: 15.10.2001		Page 1 of 2	

E&E COMP DOOR WARN SW INSP

Execution / Start Date:	
End Date:	

MAINT	RII/INSP

sabena B707	Module: E&E + LWR NOSE C	A/C Reg :	Check :	 D1F1000505
	Oper. : RT-MP LC			
	Type : REI-INSP	Issuer : A43710	Cert.St.: 24828	Page 2 of 2
Spec. : ELECTRICIAN	Release Date: 15.10.2001			

E&E COMP DOOR WARN SW INSP

					MAINT	RII/INSP
Nr.	Hardtime	Task	Spec.	Related Documents		
1.		E3 I1 W1	REI	MMS-328 527010 03010 rev 15/05/01		
Check: C						
Zones: 112						
Access:						

E & E COMPARTMENT DOOR WARNING SWITCH INSTALLATION INSPECTION.

1. Remove cover above door warning switch.
2. Detailed visual inspection for condition obvious defects and security of installation of the microswitches, pins, plungers, brackets, clamp and associated wiring of the E & E access door.
3. Reinstall cover above switch.

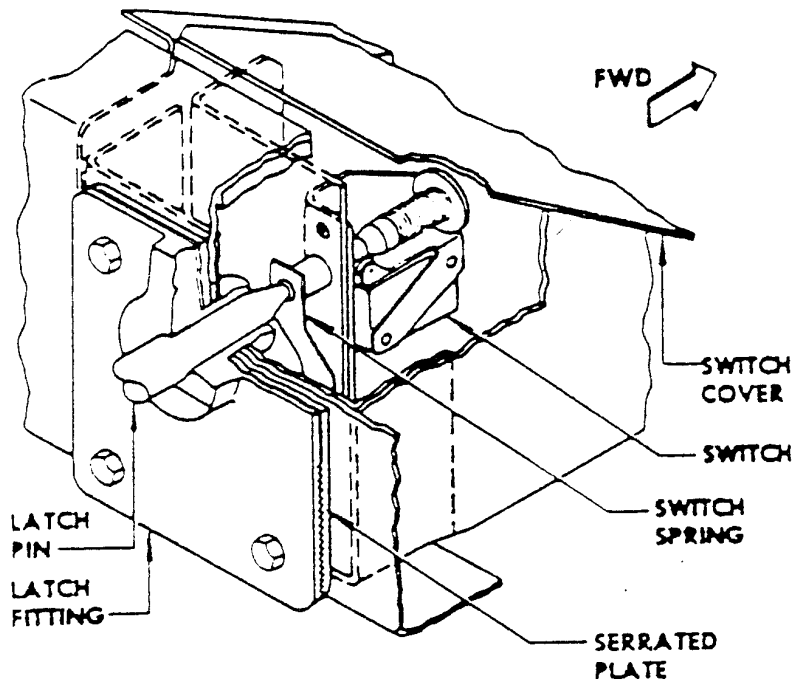

**ELECTRONIC COMPARTMENT
EXTERNAL DOOR SWITCH
INSTALLATION**