

sabena [®] B707	Module: NLG / TAIL LDG	A/C Reg :	Check :	 F1F2000001
	Oper. : RT-MP LC	Issuer : A59513	Cert.St.: 45379	
	Type : MEC-INSP	Release Date: 11.09.2008		Page 1 of 5
Spec. : MECHANIC				

DFW B707-32-0001

NOSE GEAR WHEEL SNUBBER BRAKE CRACK AT CLAMP SECTION INSP

		MAINT	RII/INSP
Execution / Start Date:			
End Date:			

DFW B707-32-0001

NOSE GEAR WHEEL SNUBBER BRAKE CRACK AT CLAMP SECTION INSP

sabena B707	Module: NLG / TAIL LDG	A/C Reg :	Check :	 F1F200001 Page 2 of 5
	Oper. : RT-MP LC	Issuer : A59513	Cert.St.: 45379	
	Type : MEC-INSP	Release Date: 11.09.2008		
Spec. : MECHANIC				

DFW B707-32-0001 NOSE GEAR WHEEL SNUBBER BRAKE CRACK AT CLAMP SECTION INSP

					MAINT	RII/INSP
Nr.	Hardtime	Task	Spec.	Related Documents		
1.		E4	MEC	DFW B707-32-0001 rev 1 SB 707-32-001 rev -		
Check: C1, C2						
Zones: 131						
Access:						
NRC YES <input type="radio"/> NO <input type="radio"/>		IF YES, NUMBER(S):				

NOSE GEAR WHEEL SNUBBER BRAKE CRACKS

1. Gain access to the nose landing gear wheel snubber brake assemblies.
2. Remove the nose gear wheel snubber filler, 66-13388-2.
3. Perform a high frequency eddy current inspection of the bores and surface around the four (4) attaching fastener holes i.a.w. Chapter 51-06-00 of D6-48023 "Non Destructive Test Manual".

Cracked nose gear wheel snubber brake bands should be immediately repaired, replaced, or removed from the airplane. Operation of the airplane without the nose gear wheel snubber assembly installed is allowed, but the flight crew may hear additional noise coming from the nose wheel well as the nose gear wheels gradually spin down.

If findings are found => Repair per DFW-B707-32-0001.

4. Install the nose gear wheel snubber filler, 66-13388-2.

sabena B707	Module: NLG / TAIL LDG	A/C Reg :	Check :	 F1F200001
	Oper. : RT-MP LC	Issuer : A59513	Cert.St.: 45379	
	Type : MEC-INSP	Release Date: 11.09.2008	Page 3 of 5	
Spec. : MECHANIC				

DFW B707-32-0001

NOSE GEAR WHEEL SNUBBER BRAKE CRACK AT CLAMP SECTION INSP

T.O. ~~MM1E-3A-4-32-1~~

MAINT RII/INSP

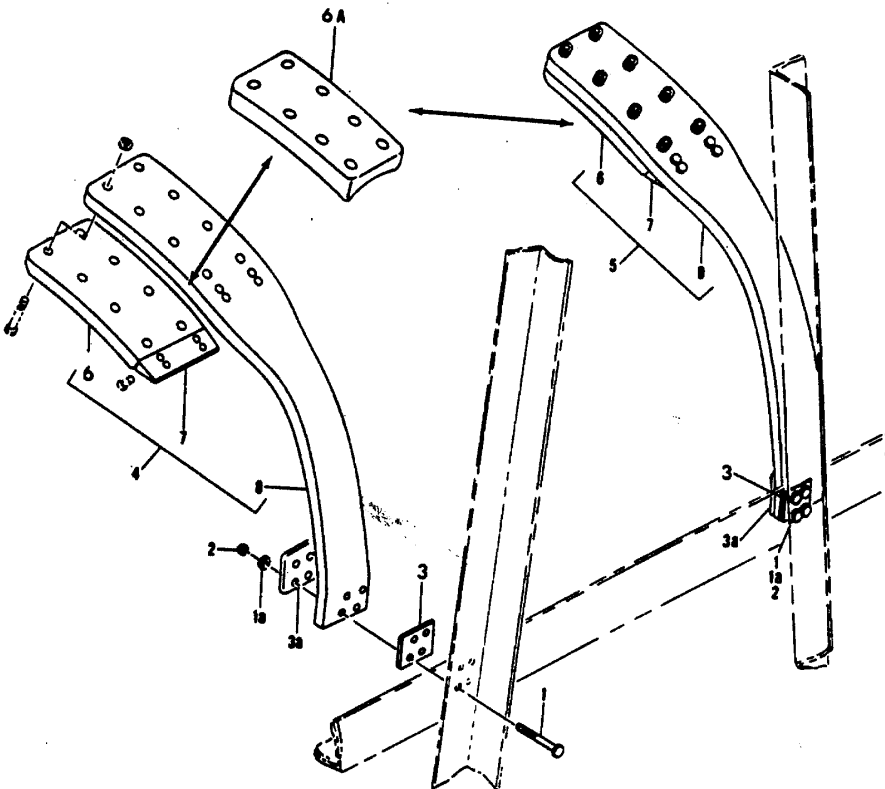
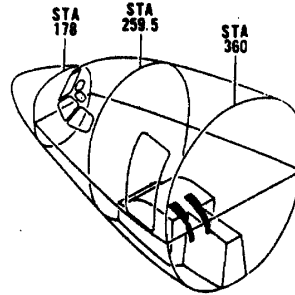

SEE NOTE ON PARTS LIST PAGES
 FIGURE 19. BRAKE INSTL, NOSE GEAR WHEEL SNUBBER

DETAILED PARTS LIST
 32-03-19
 PAGE 0

32-03-19

MAR 1/90

DFW B707-32-0001

NOSE GEAR WHEEL SNUBBER BRAKE CRACK AT CLAMP SECTION INSP

sabena B707	Module: NLG / TAIL LDG	A/C Reg :	Check :	 F1F200001
	Oper. : RT-MP LC	Issuer : A59513	Cert.St.: 45379	
	Type : MEC-INSP	Release Date: 11.09.2008		Page 4 of 5
Spec. : MECHANIC				

DFW B707-32-0001 NOSE GEAR WHEEL SNUBBER BRAKE CRACK AT CLAMP SECTION INSP

					MAINT	RII/INSP
Nr.	Hardtime	Task	Spec.	Related Documents		
2.		E3	MEC	DFW B707-32-0001 rev 1 MMS-328 533230 01000 rev 25.01.08 SB 707-32-001 rev -		
Check: C						
Zones: 131						
Access:						
NRC YES <input type="radio"/> NO <input type="radio"/>		IF YES, NUMBER(S):				

NOSE GEAR WHEEL SNUBBER BRAKE CRACKS

1. Gain access to the nose landing gear wheel snubber brake assemblies.
2. Remove the nose gear wheel snubber filler, 66-13388-2.
3. Perform a close visual inspection of the four (4) attaching fasteners & the area around the fasteners for corrosion or cracks.
If findings are found => Repair per DFW-B707-32-0001.
4. Install the nose gear wheel snubber filler, 66-13388-2.

sabena B707	Module: NLG / TAIL LDG	A/C Reg :	Check :	 F1F200001
	Oper. : RT-MP LC	Issuer : A59513	Cert.St.: 45379	
	Type : MEC-INSP	Release Date: 11.09.2008	Page 5 of 5	
Spec. : MECHANIC				

DFW B707-32-0001

NOSE GEAR WHEEL SNUBBER BRAKE CRACK AT CLAMP SECTION INSP

T.O. ~~MM1E-3A-4-32-1~~

MAINT RII/INSP

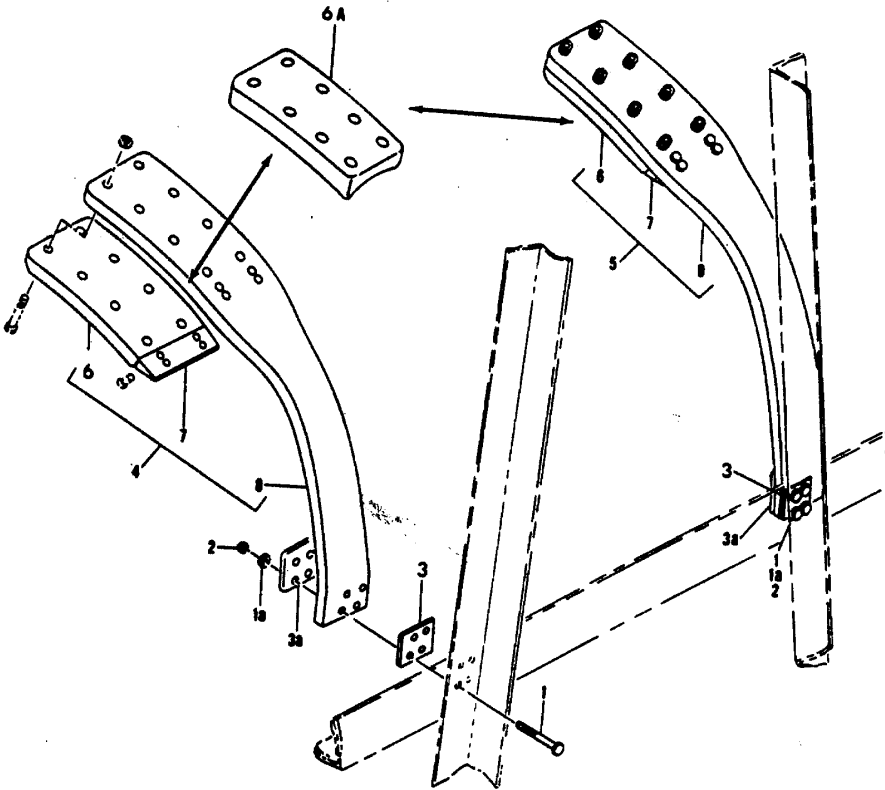
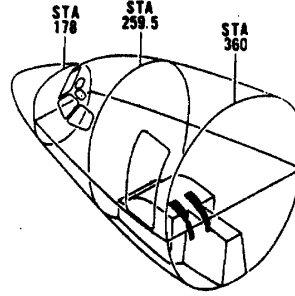

SEE NOTE ON PARTS LIST PAGES
 FIGURE 19. BRAKE INSTL, NOSE GEAR WHEEL SNUBBER

DETAILED PARTS LIST
 32-03-19
 PAGE 0

32-03-19

MAR 1/90

DFW B707-32-0001

NOSE GEAR WHEEL SNUBBER BRAKE CRACK AT CLAMP SECTION INSP