

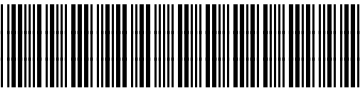

sabena [®] B707	Module: NLG WW + DOORS	A/C Reg :	Check :	 G1F3000501
	Oper. : RT-MP LC			
	Type : STRUCT-INSP	Issuer : A43710	Cert.St.: 24828	Page 1 of 4
Spec. : MECH. INSP	Release Date: 15.10.2001			

NWW SIDEWALL FASTENERS INSP

Execution / Start Date:	
End Date:	

MAINT	RII/INSP

sabena B707	Module: NLG WW + DOORS	A/C Reg :	Check :	 G1F3000501 Page 2 of 4
	Oper. : RT-MP LC	Issuer : A43710	Cert.St.: 24828	
	Type : STRUCT-INSP	Release Date: 15.10.2001		
Spec. : MECH. INSP				

NWW SIDEWALL FASTENERS INSP

					MAINT	RII/INSP
Nr.	Hardtime	Task	Spec.	Related Documents		
1.		E3	INS	AD 94-10-06 rev 8913 MMS-328 533240 02000 rev 15/05/01 SB 707-53-2838 rev 1		
Check: C						
Zones: 131						
Access:						

NWW SIDEWALL FASTENERS INSPECTION.

Visually inspect the areas of the NWW side panels along horizontal rivet rows between WL 175 + 150 from BS 322 to 294.5 & along the vertical rivet rows between upper edge of panel & WL 150 from BS 330 to 312 per SB 2838 Rev 1. PARA C & section 2 accomplishment instructions A-E & Fig 2 + 3.

- 1 NOT APPLICABLE TO AV 720-059B; CO 707-321C AND 707-324C; AND PA 707-121B, 707-321, 707-321B AND 707-321C.
- 2 WASHER STRIP "A" CUT TO LENGTH (INSTALL)
- 3 RETAIN IMPREG SHIM
- 4 NO PARTS OR FASTENER PATTERNS SHOWN FOR CLARITY ALONG STATION PLANES

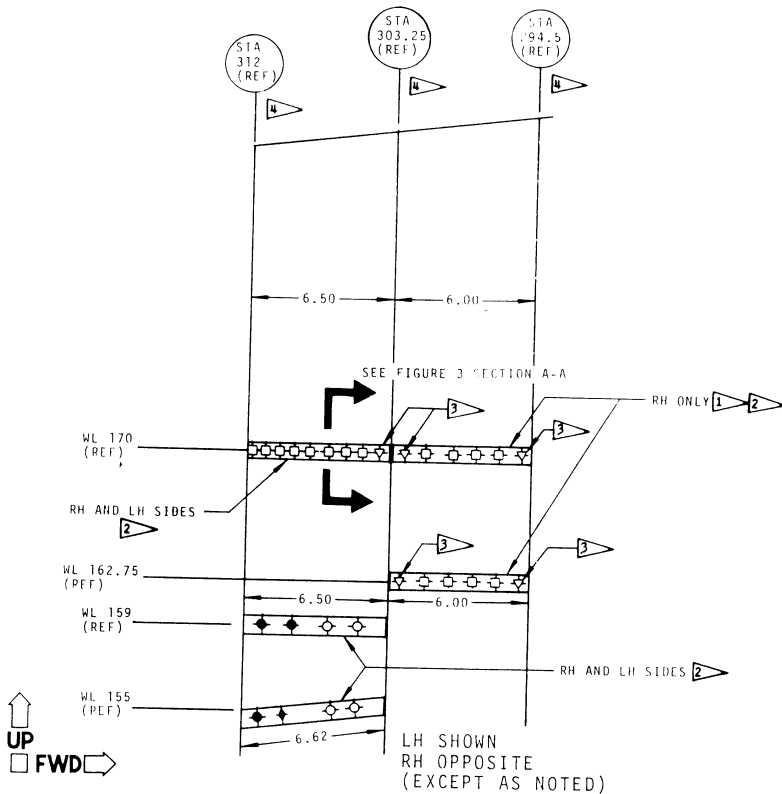



FIGURE 2.

sabena B707	Module: NLG WW + DOORS	A/C Reg :	Check :	 G1F3000501 Page 3 of 4
	Oper. : RT-MP LC	Issuer : A43710	Cert.St.: 24828	
	Type : STRUCT-INSP	Release Date: 15.10.2001		
Spec. : MECH. INSP				

NWW SIDEWALL FASTENERS INSP

MAINT RII/INSP

- 1 WASHER STRIP "A": CUT TO LENGTH (INSTALL)
- 2 WASHER STRIP "B": CUT TO LENGTH (INSTALL)
- 3 RETAIN TAPERED SHIM
- 4 NO PARTS OR FASTENER PATTERNS SHOWN ALONG STATION PLANES FOR CLARITY

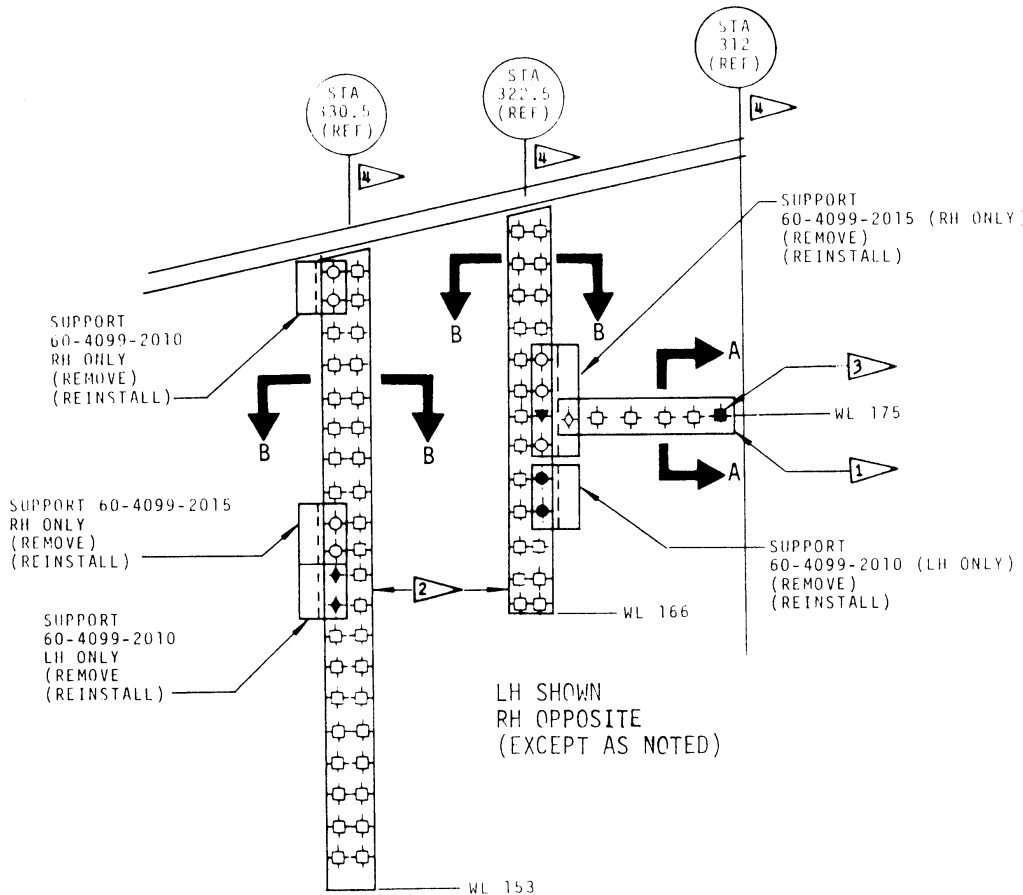



FIGURE 3.

sabena B707	Module: NLG WW + DOORS	A/C Reg :	Check :	 G1F300501
	Oper. : RT-MP LC	Issuer : A43710	Cert.St.: 24828	
	Type : STRUCT-INSP	Release Date: 15.10.2001		Page 4 of 4
	Spec. : MECH. INSP			

NWW SIDEWALL FASTENERS INSP

MAINT RII/INSP

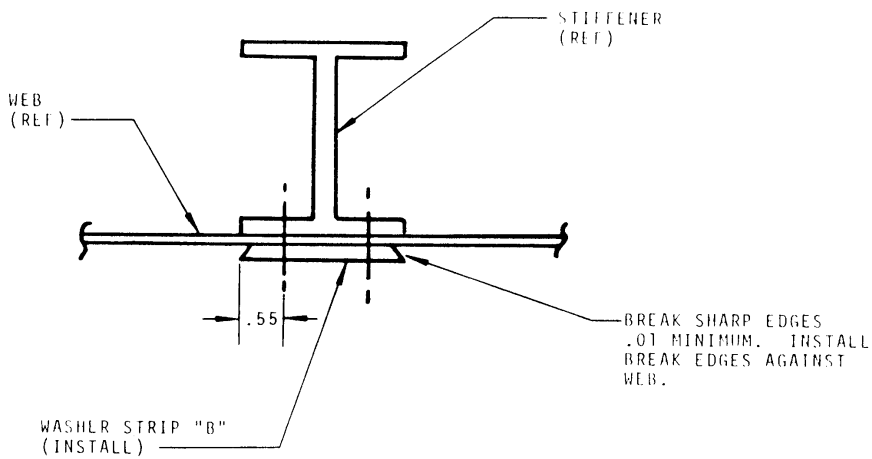
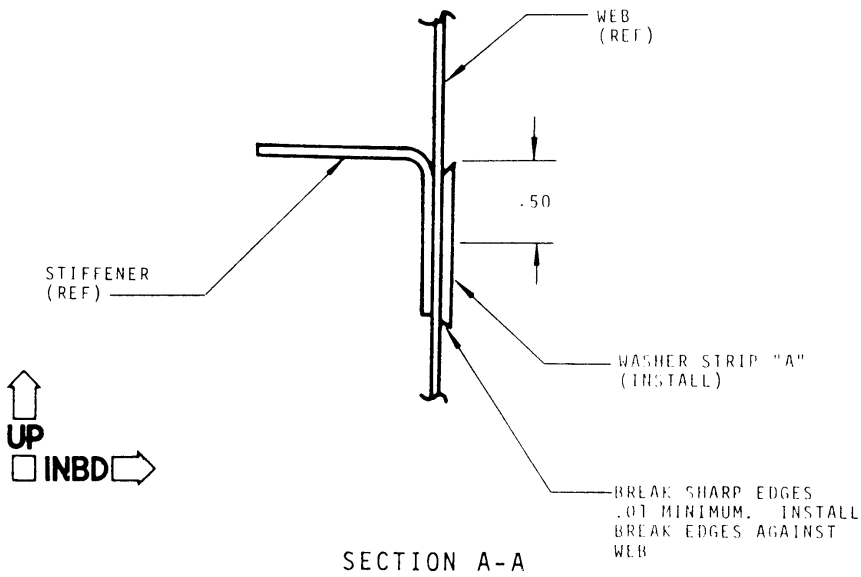

FIGURE 3.