

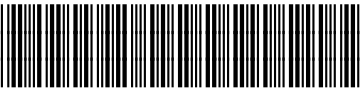

sabena [®] B707	Module: MLG / CLG	A/C Reg :	Check :	 H1F4000505
	Oper. : RT-MP LC			
	Type : NDT INSP	Issuer : A59513	Cert.St.: 46928	Page 1 of 6
Spec. : MECH. INSP	Release Date: 29.11.2005			

LH WING MLG TORQUE BOX & STEEL RIB HFEC INSP

Execution / Start Date:	
End Date:	

MAINT	RII/INSP

sabena B707	Module: MLG / CLG	A/C Reg :	Check :	 H1F4000505 Page 2 of 6
	Oper. : RT-MP LC			
	Type : NDT INSP	Issuer : A59513	Cert.St.: 46928	
	Spec. : MECH. INSP	Release Date: 29.11.2005		

LH WING MLG TORQUE BOX & STEEL RIB HFEC INSP

					MAINT	RII/INSP
Nr.	Hardtime	Task	Spec.	Related Documents		
1.		BT2 E4	INS	CPCP-TC C57-581-02 P3 rev 25 AUG 95 DEI 57-A3510 rev 07/06/2004 MMS-328 575000 07001 rev 09.07.04		
Check: C						
Zones: 584						
Access: 1234 L, 1254 L, 1324 L, 1346L, 1347L, 1350L, 1453L, 1454L						
NRC YES <input type="radio"/> NO <input type="radio"/>		IF YES, NUMBER(S):				

LH wing MLG torque box & steel rib inspection.

1. Remove all corrosion inhibiting compound and/or sealant from both sides of the rib flanges, web radius & around all bolt heads/nuts & fasteners heads/collars.
Do not use a pressure water.

2. Do a HFEC inspection on both sides of the web flange, the flange radius & around all bolt heads/nuts & fastener heads/collars for both upper & lower chords & on the rib around the edge of the MLG trunnion support fitting.
Refer to 707 NDT Manual, Part 6, 51-00-00, Figure 24.

If cracks of any length are found during the HFEC inspection contact Boeing for instruction for a FAA approved repair procedure.

DR number

3. Apply BMS 3-23 to all exposed surfaces of the MLG trunnion support fitting, both sides of the flange radius of the upper & lower chords & the rib support.

NOTE: For the treatment of areas where a scraper was used to remove the finish & the finish was blended smooth to bare metal refer to BSOPM 20-10-01.

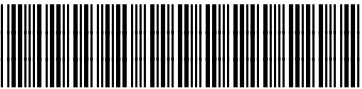
sabena B707	Module: MLG / CLG	A/C Reg :	Check :	 H1F4000505
	Oper. : RT-MP LC			
	Type : NDT INSP	Issuer : A59513	Cert.St.: 46928	Page 3 of 6
	Spec. : MECH. INSP	Release Date: 29.11.2005		

LH WING MLG TORQUE BOX & STEEL RIB HFEC INSP

MAINT	RII/INSP

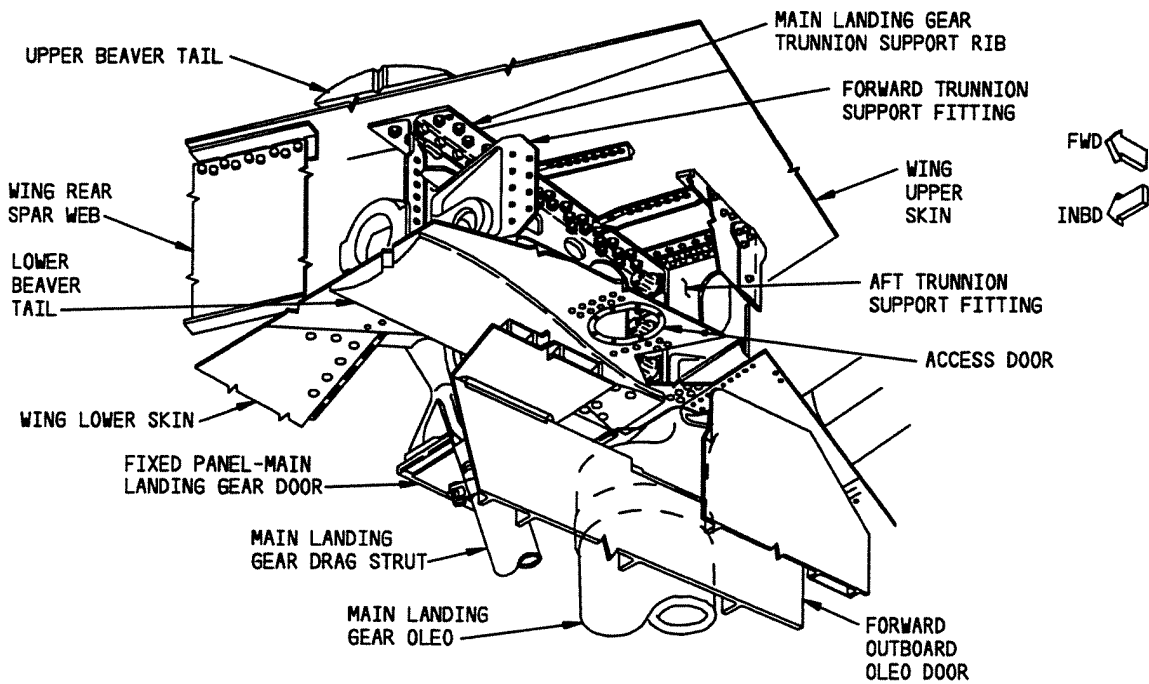
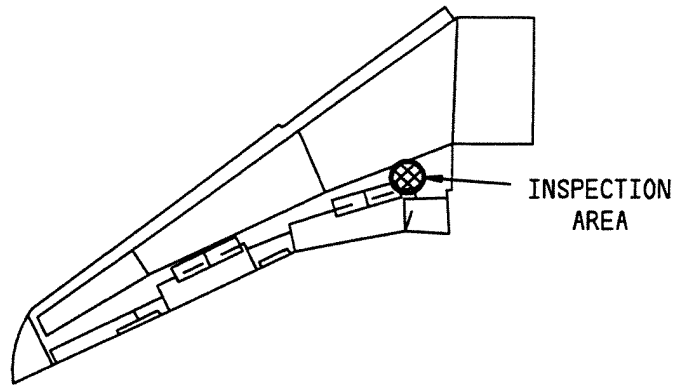

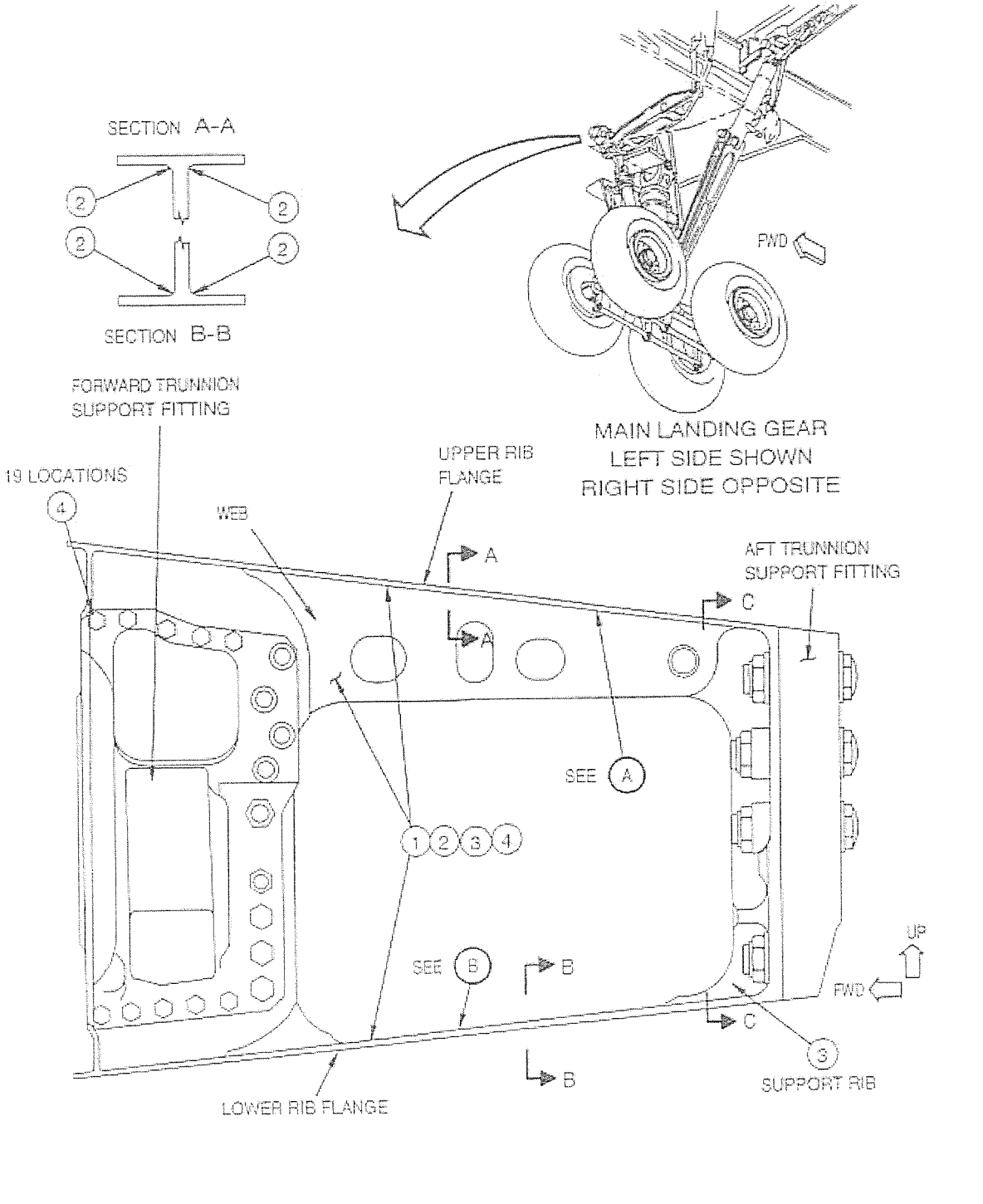



fig 01

sabena B707	Module: MLG / CLG	A/C Reg :	Check :	
	Oper. : RT-MP LC			
	Type : NDT INSP	Issuer : A59513	Cert.St.: 46928	H1F4000505
	Spec. : MECH. INSP	Release Date: 29.11.2005		Page 4 of 6

LH WING MLG TORQUE BOX & STEEL RIB HFEC INSP

	MAINT	RII/INSP
		

LH WING MLG TORQUE BOX & STEEL RIB HFEC INSP

sabena B707	Module: MLG / CLG	A/C Reg :	Check :	 H1F4000505
	Oper. : RT-MP LC			
	Type : NDT INSP	Issuer : A59513	Cert.St.: 46928	Page 5 of 6
	Spec. : MECH. INSP	Release Date: 29.11.2005		

LH WING MLG TORQUE BOX & STEEL RIB HFEC INSP

MAINT	RII/INSP

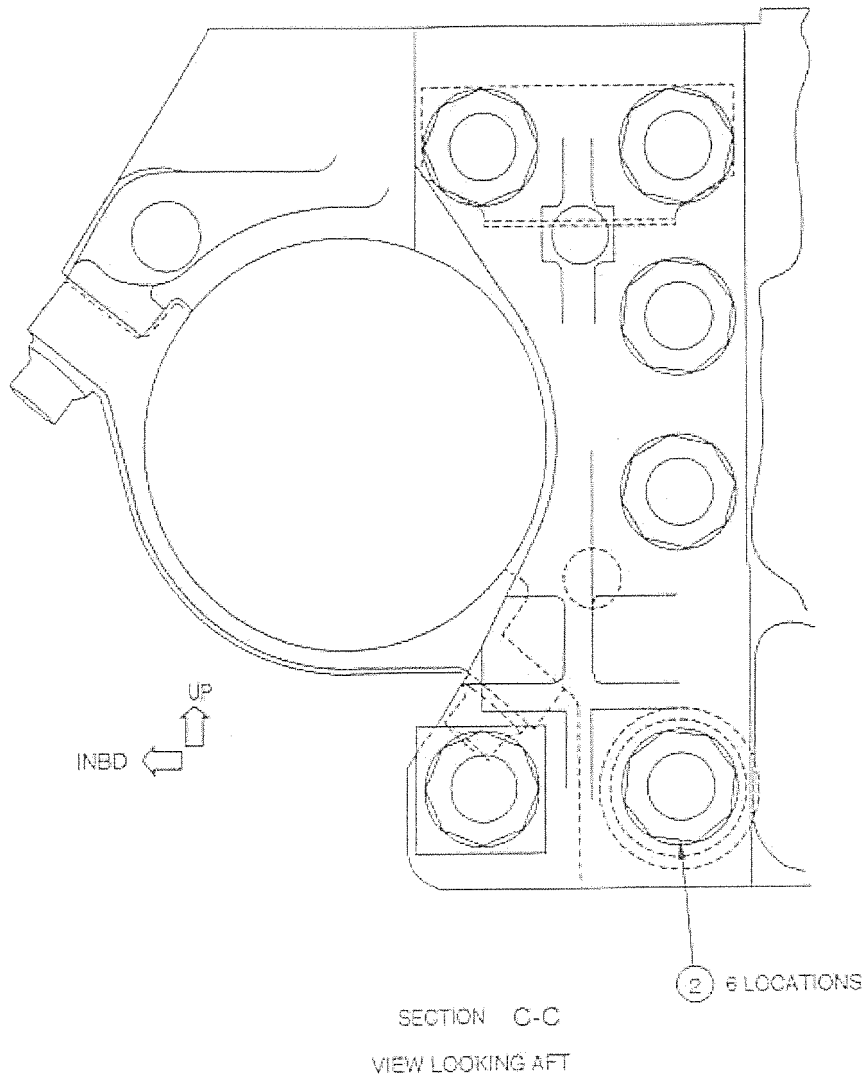

LH WING MLG TORQUE BOX & STEEL RIB HFEC INSP

sabena B707	Module: MLG / CLG	A/C Reg :	Check :	 H1F4000505
	Oper. : RT-MP LC			
	Type : NDT INSP	Issuer : A59513	Cert.St.: 46928	Page 6 of 6
	Spec. : MECH. INSP	Release Date: 29.11.2005		

LH WING MLG TORQUE BOX & STEEL RIB HFEC INSP

MAINT RII/INSP

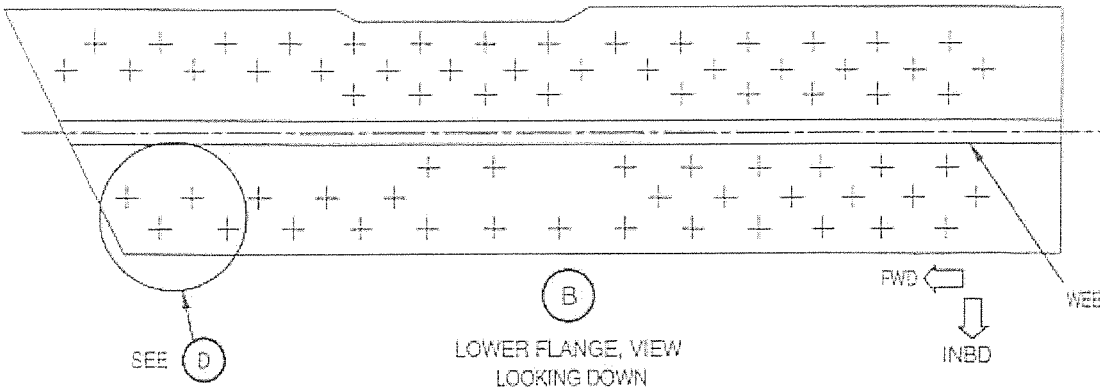
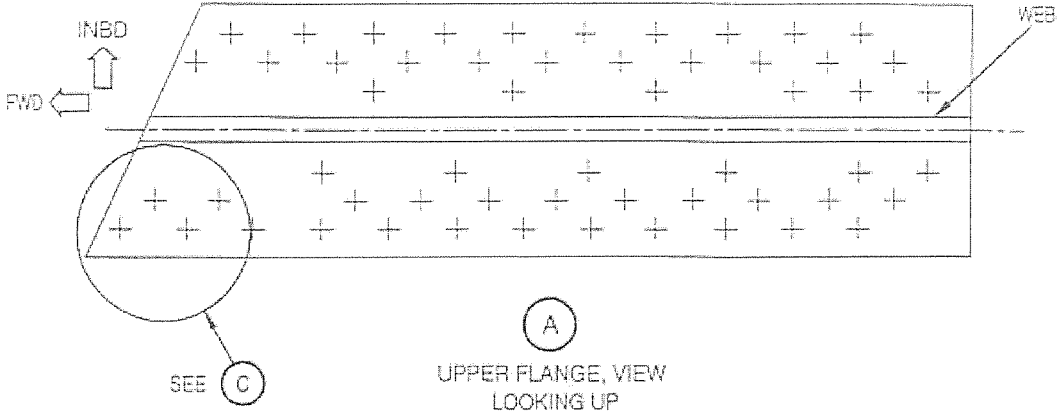

56 LOCATIONS (APPROXIMATE)

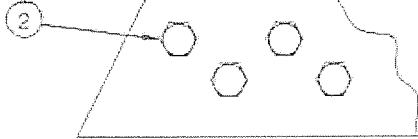

70 LOCATIONS (APPROXIMATE)

