



|                              |                          |                 |                    |  |
|------------------------------|--------------------------|-----------------|--------------------|--|
| <b>sabena</b><br><b>B707</b> | Module: MLG WW + DOORS   | A/C Reg :       | Check :            |  |
|                              | Oper. : RT-MP LC         |                 |                    |  |
|                              | Type : *LUBE*            | Issuer : A59513 | Cert.St.: 45379    | <b>I110000500</b>  |
| Spec. : MECHANIC             | Release Date: 14.07.2008 |                 | <b>Page 1 of 7</b> |  |

**LH MLG LUB**

|                         |  |
|-------------------------|--|
| Execution / Start Date: |  |
| End Date:               |  |

**MAINT**      **RII/INSP**

| Pos | Mat. Type | P/N           | IDN | Description    | Qty  | Unit |
|-----|-----------|---------------|-----|----------------|------|------|
| 1   | FL & CH   | MIL-PRF-23827 |     | BMS3-33        | 1.00 | EA   |
| 1   | FL & CH   | MIL-L-7870    |     | INSTRUMENT OIL | 1.00 | EA   |

|                       |                        |                          |                    |   |
|-----------------------|------------------------|--------------------------|--------------------|---|
| <b>sabena</b><br>B707 | Module: MLG WW + DOORS | A/C Reg :                | Check :            | <br><b>I110000500</b> |
|                       | Oper. : RT-MP LC       | Issuer : A59513          | Cert.St.: 45379    |   |
|                       | Type : *LUBE*          | Release Date: 14.07.2008 | <b>Page 2 of 7</b> |   |
| Spec. : MECHANIC      |                        |                          |                    |   |

**LH MLG LUB**

|  |          |                          |       |                                   | MAINT | RII/INSP |  |
|--|----------|--------------------------|-------|-----------------------------------|-------|----------|--|
| Nr.  | Hardtime | Task                     | Spec. | Related Documents                 |       |          |  |
| 1.   |          | S                        | MEC   | MMS-328 321010 00101 rev 15/05/01 |       |          |  |
| Check: C   |          |                          |       |                                   |       |          |  |
| Zones: 135   |          |                          |       |                                   |       |          |  |
| Access:  |          |                          |       |                                   |       |          |  |
| NRC YES <input type="radio"/> NO <input type="radio"/> |          | IF YES, NUMBER(S): ..... |       |                                   |       |          |  |

**LUBRICATE LH MAIN LANDING GEAR.**

(Mark with 'X' at each lube location)

Lubrication of the LH MAIN LANDING GEAR I.A.W following figures.

NOTE: Remove excess of grease & clean contamination areas in the immediate vicinity

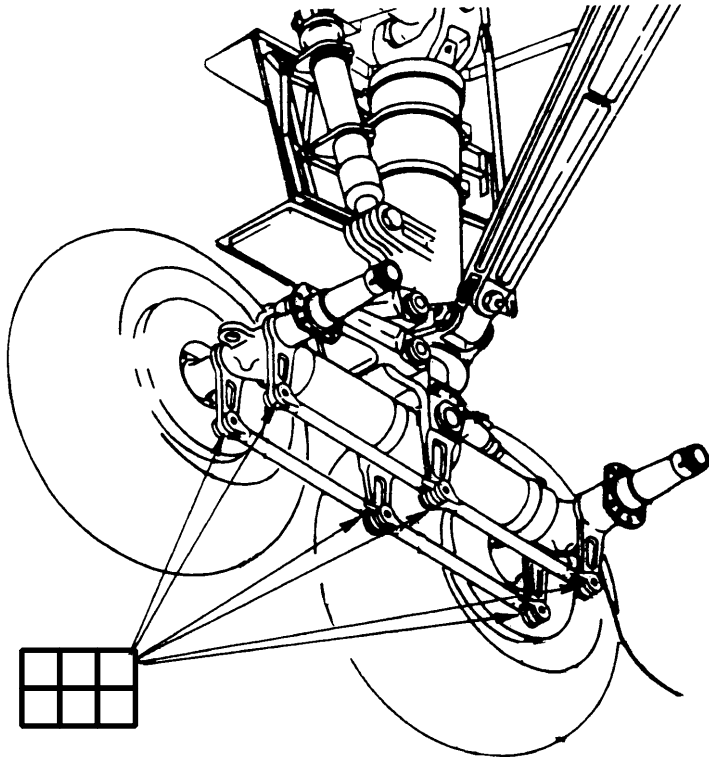

|                       |                        |                          |                 |  |
|-----------------------|------------------------|--------------------------|-----------------|--|
| <b>sabena</b><br>B707 | Module: MLG WW + DOORS | A/C Reg :                | Check :         | <br>1110000500 |
|                       | Oper. : RT-MP LC       | Issuer : A59513          | Cert.St.: 45379 |  |
|                       | Type : *LUBE*          | Release Date: 14.07.2008 | Page 3 of 7     |  |
| Spec. : MECHANIC      |                        |                          |                 |  |

LH MLG LUB

| MAINT | RII/INSP |
|-------|----------|
|       |          |

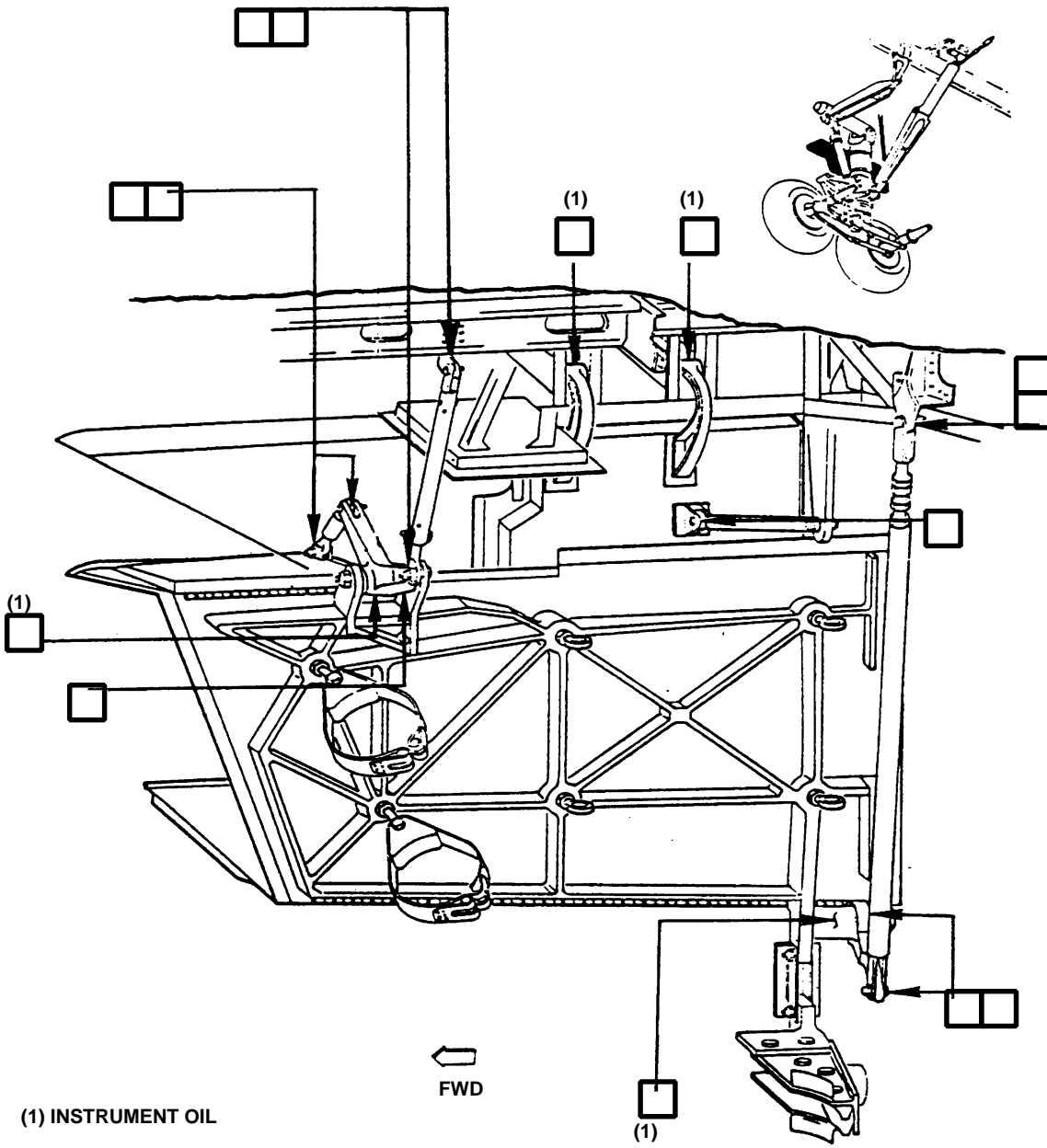

|                       |                        |                          |                    |   |
|-----------------------|------------------------|--------------------------|--------------------|---|
| <b>sabena</b><br>B707 | Module: MLG WW + DOORS | A/C Reg :                | Check :            | <br><b>1110000500</b> |
|                       | Oper. : RT-MP LC       | Issuer : A59513          | Cert.St.: 45379    |   |
|                       | Type : *LUBE*          | Release Date: 14.07.2008 | <b>Page 4 of 7</b> |   |
| Spec. : MECHANIC      |                        |                          |                    |   |

LH MLG LUB

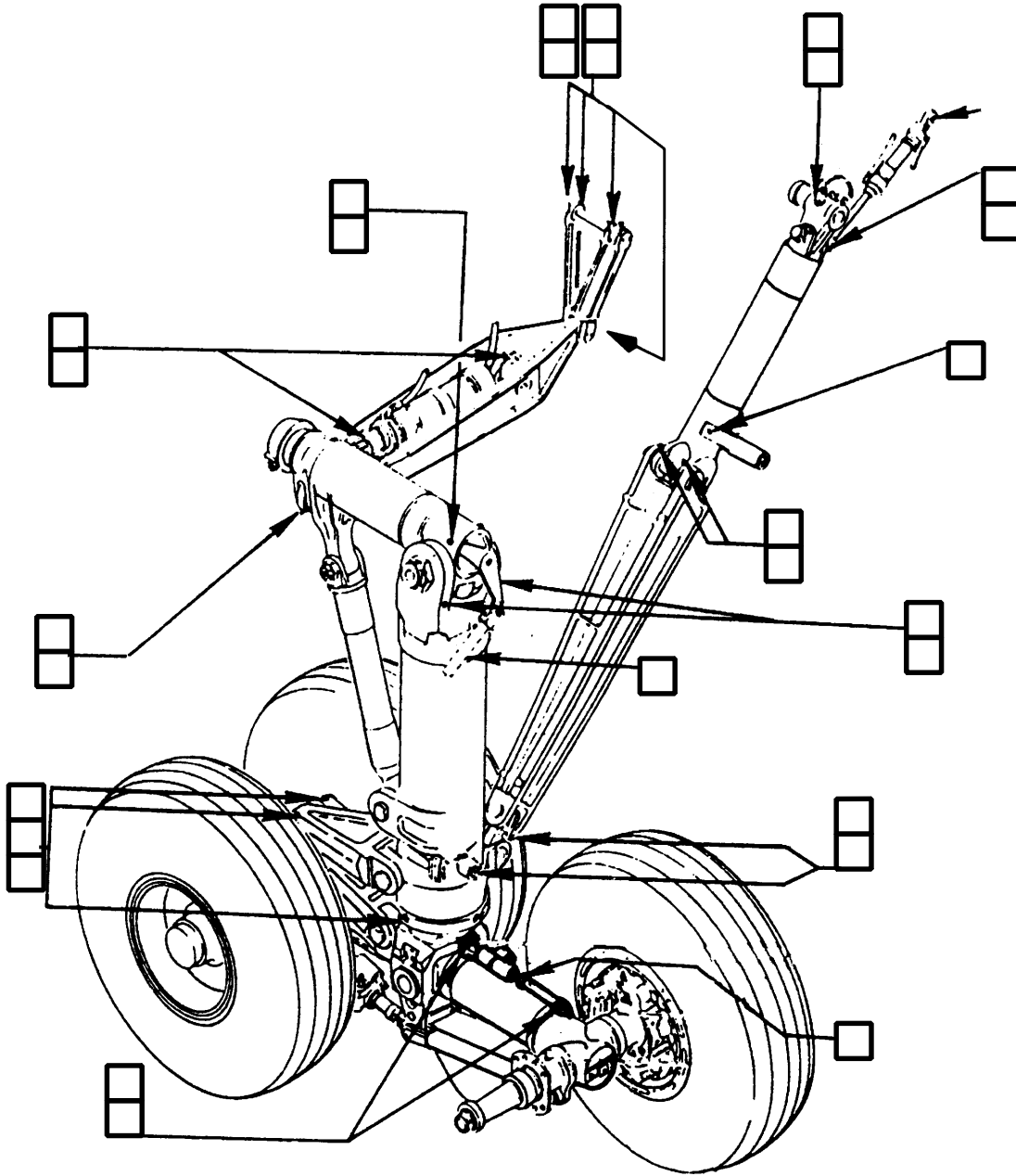

| MAINT | RII/INSP |
|-------|----------|
|       |          |

|                       |                        |                          |                 |   |
|-----------------------|------------------------|--------------------------|-----------------|---|
| <b>sabena</b><br>B707 | Module: MLG WW + DOORS | A/C Reg :                | Check :         | <br><b>I110000500</b> |
|                       | Oper. : RT-MP LC       |                          |                 |   |
|                       | Type : *LUBE*          | Issuer : A59513          | Cert.St.: 45379 | <b>Page 5 of 7</b>  |
|                       | Spec. : MECHANIC       | Release Date: 14.07.2008 |                 |   |

LH MLG LUB

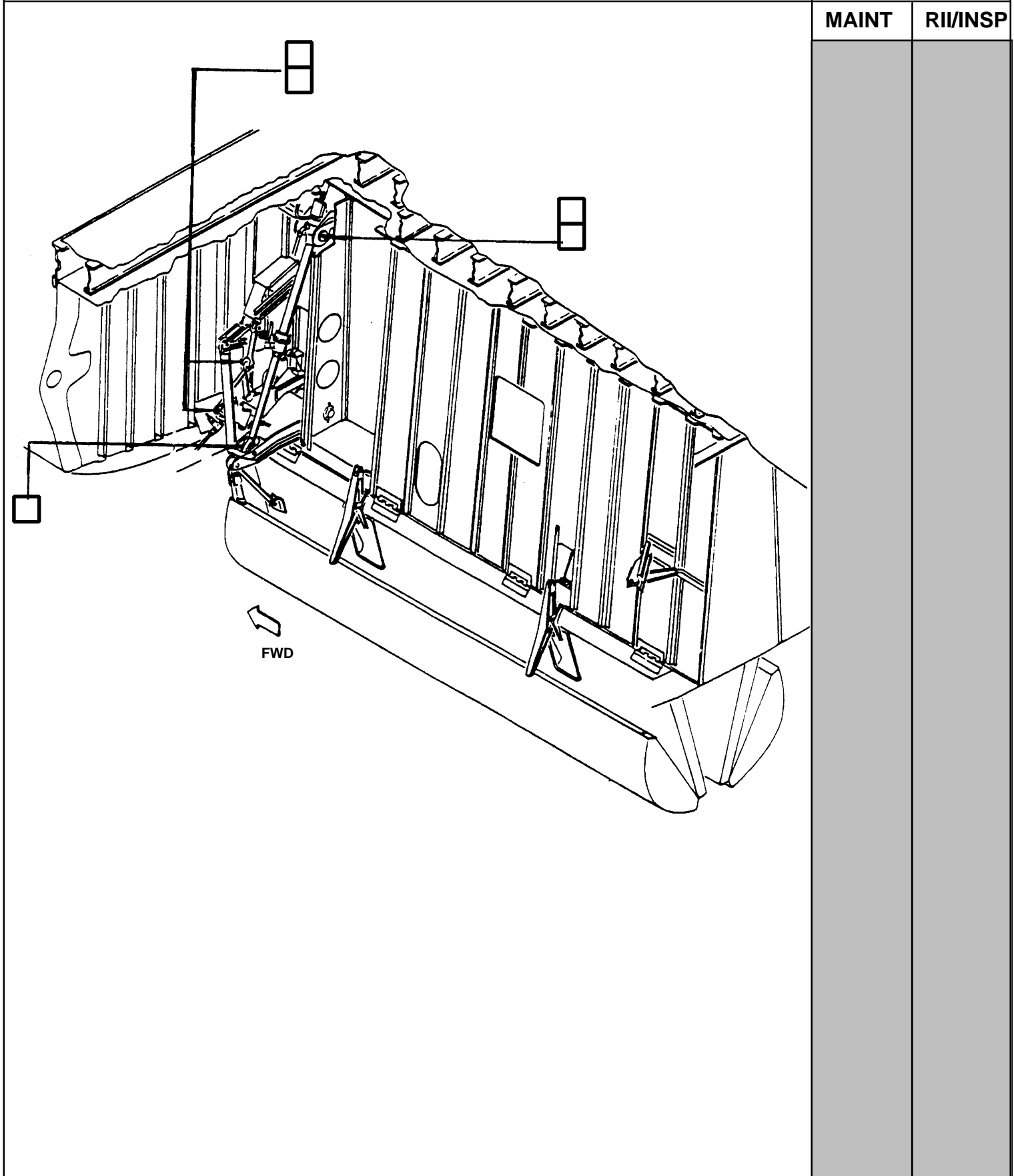

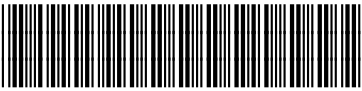

LH MLG LUB

|                       |                        |                          |                    |   |
|-----------------------|------------------------|--------------------------|--------------------|---|
| <b>sabena</b><br>B707 | Module: MLG WW + DOORS | A/C Reg :                | Check :            | <br><b>1110000500</b> |
|                       | Oper. : RT-MP LC       | Issuer : A59513          | Cert.St.: 45379    |   |
|                       | Type : *LUBE*          | Release Date: 14.07.2008 | <b>Page 6 of 7</b> |   |
| Spec. : MECHANIC      |                        |                          |                    |   |

LH MLG LUB

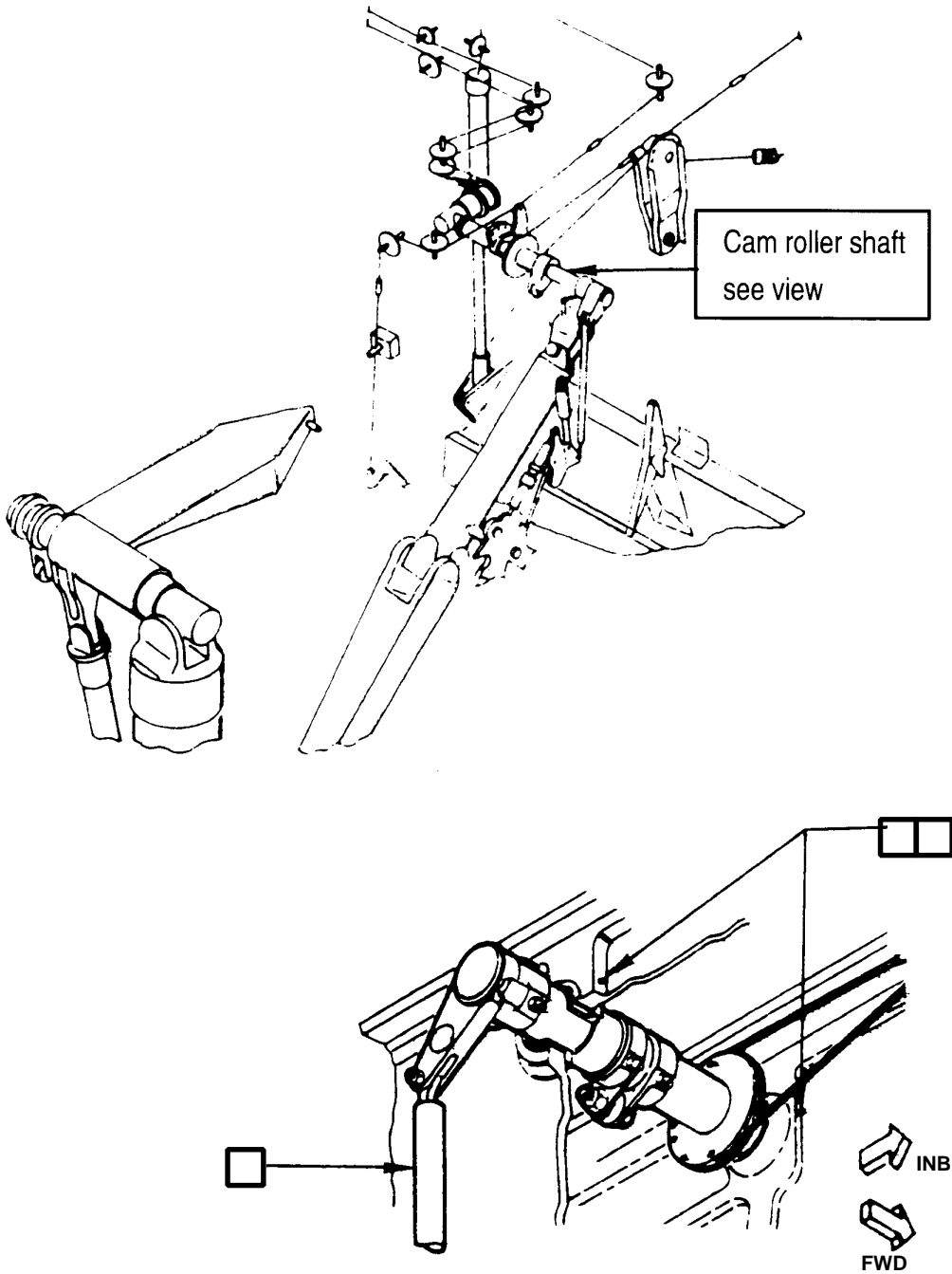
| MAINT | RII/INSP |
|-------|----------|
|       |          |



|                       |                        |                          |                 |  |
|-----------------------|------------------------|--------------------------|-----------------|--|
| <b>sabena</b><br>B707 | Module: MLG WW + DOORS | A/C Reg :                | Check :         |  |
|                       | Oper. : RT-MP LC       |                          |                 |  |
|                       | Type : *LUBE*          | Issuer : A59513          | Cert.St.: 45379 | 1110000500   |
|                       | Spec. : MECHANIC       | Release Date: 14.07.2008 |                 | Page 7 of 7  |

LH MLG LUB

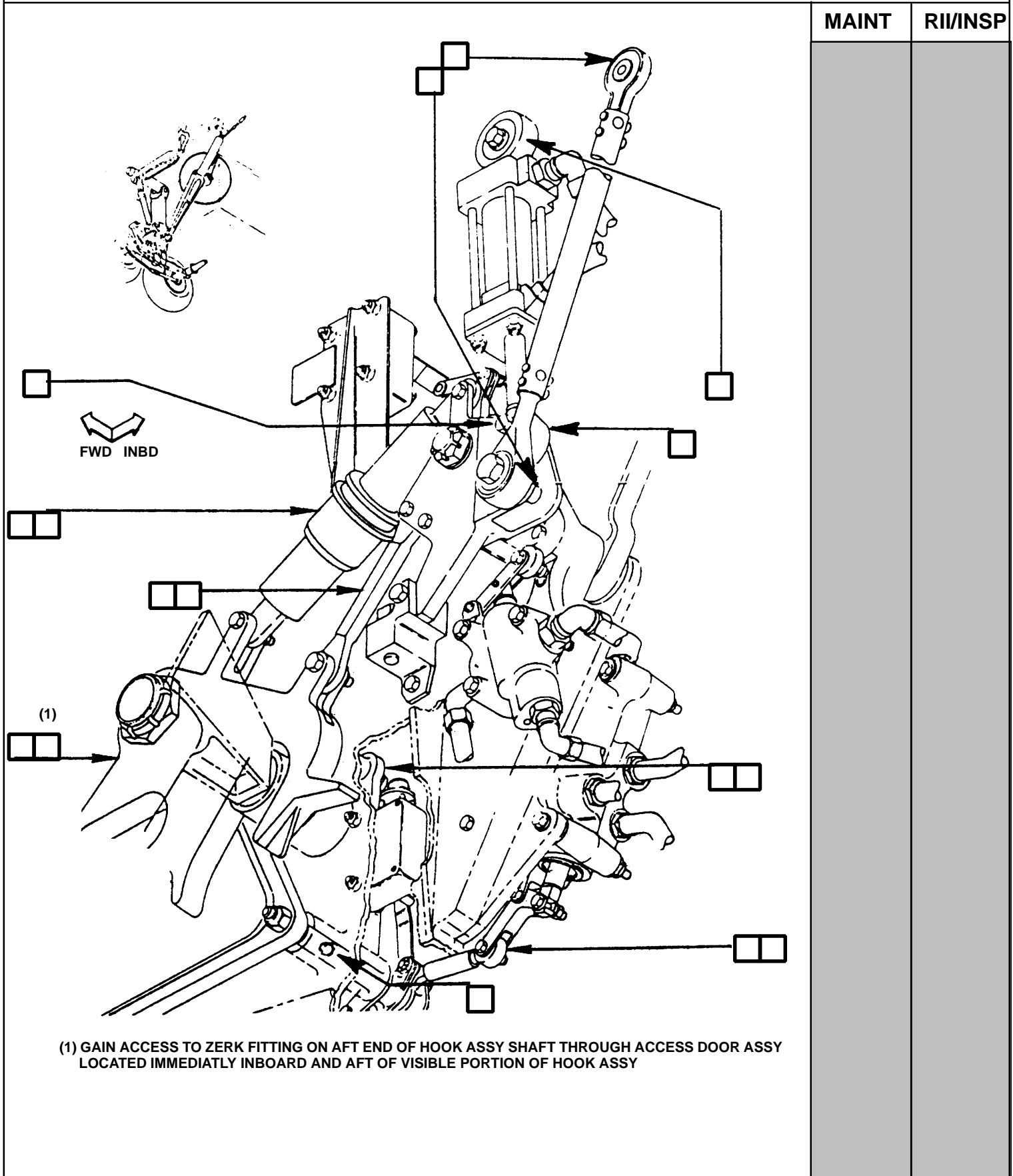

| MAINT | RII/INSP |
|-------|----------|
|       |          |

(1) GAIN ACCESS TO ZERK FITTING ON AFT END OF HOOK ASSY SHAFT THROUGH ACCESS DOOR ASSY LOCATED IMMEDIATLY INBOARD AND AFT OF VISIBLE PORTION OF HOOK ASSY

LH MLG LUB