



sabena [®] B707	Module: TAIL CMPT	A/C Reg :	Check :	 M1E0000502
	Oper. : RT-MP LC			
	Type : * ZONAL INSP*	Issuer : A43710	Cert.St.: 24828	Page 1 of 3
Spec. : MECHANIC	Release Date: 15.10.2001			

HOR STAB CTR SECT FRONT SPAR INSP

Execution / Start Date:	
End Date:	

MAINT	RII/INSP

sabena B707	Module: TAIL CMPT	A/C Reg :	Check :	
	Oper. : RT-MP LC			
	Type : * ZONAL INSP*	Issuer : A43710	Cert.St.: 24828	M1E0000502
	Spec. : MECHANIC	Release Date: 15.10.2001		Page 2 of 3

HOR STAB CTR SECT FRONT SPAR INSP

					MAINT	RII/INSP
Nr.	Hardtime	Task	Spec.	Related Documents		
1.		E3 E4	MEC	AD 70-02-11 rev . AD 91-07-07 rev . AD 92-04-01 rev 8170 MMS-328 533550 01000 rev 15/05/01 SB 707-55-2959 rev 4 SB 707-55-3067 rev . SB 707-55A3482 rev .		
Check: C						
Zones:						
Access: 1185 L						

HORIZONTAL STAB CTR SECTION FRONT SPAR INSPECTION.

1. Close visual inspection of the front spar lower lug.
2. Perform a ultrasonic inspection of the front spar lower lug.
3. Close visual inspection of the front spar chord flange at the fasteners attaching the upper & lower skin panel to the flange.

sabena B707	Module: TAIL CMPT	A/C Reg :	Check :	
	Oper. : RT-MP LC	Issuer : A43710	Cert.St.: 24828	
	Type : * ZONAL INSP*	Release Date: 15.10.2001	Page 3 of 3	
Spec. : MECHANIC				

HOR STAB CTR SECT FRONT SPAR INSP

MAINT RII/INSP

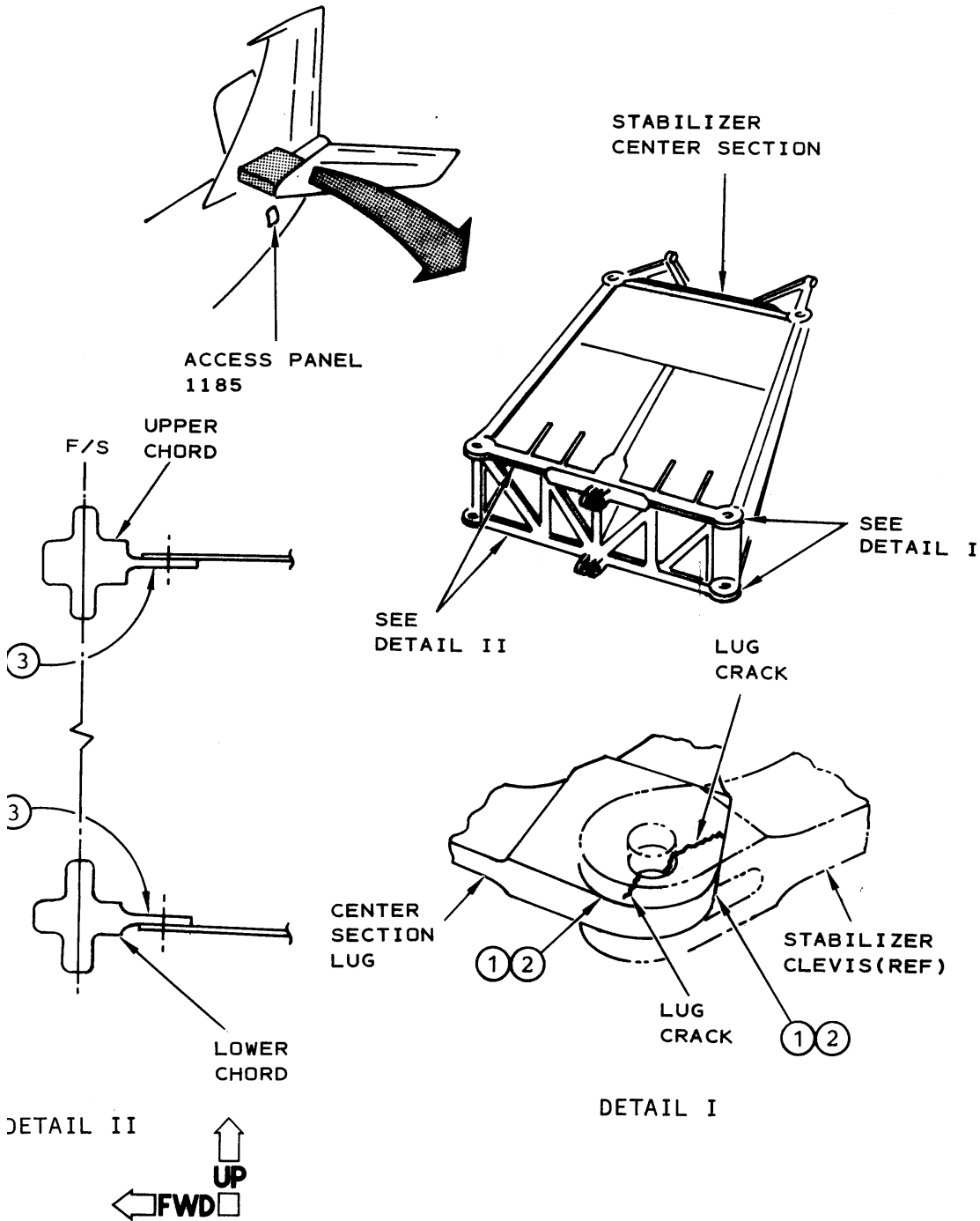

FIGURE 1. LUG AND FLANGE INSPECTION