



sabena B707	Module: ENGINE 1	A/C Reg :	Check :	
	Oper. : RT-MP LC			
	Type : SERVICING	Issuer : A43710	Cert.St.: 24828	N1H1000504
	Spec. : MECHANIC	Release Date: 17.10.2001		Page 1 of 3

ENG #1 CSD OIL FILTER REPL

Execution / Start Date:	
End Date:	

MAINT **RII/INSP**

Pos	Mat. Type	P/N	IDN	Description	Qty	Unit
1	CONSUM	7578137-101	347239	FILTER	1.00	EA
1	CONSUM	7583142	346746	FILTER	1.00	EA
1	CONSUM	M 83248-1-014	421691	O RING	1.00	EA
1	CONSUM	M 83248-1-018	287842	O RING	1.00	EA
1	CONSUM	M 83248-1-128	287810	O RING	1.00	EA
1	CONSUM	MS 28782-19	863540	O RING	1.00	EA
1	CONSUM	MS 9388-214	548335	O RING	1.00	EA
1	CONSUM	MS 9388-228	291425	O RING	1.00	EA
1	FL & CH	28 075 3442		ACRYLOID HF 825	0.00	
1	FL & CH	28 033 1002		VASELINE	0.00	
1	TOOL	L-452A	150510	TORQUEMETER	1.00	EA
1	TOOL	L-465A	150508	TORQUEMETER	0.00	

sabena B707	Module: ENGINE 1	A/C Reg :	Check :	 N1H1000504 Page 2 of 3
	Oper. : RT-MP LC			
	Type : SERVICING	Issuer : A43710	Cert.St.: 24828	
	Spec. : MECHANIC	Release Date: 17.10.2001		

ENG #1 CSD OIL FILTER REPL

					MAINT	RII/INSP
Nr.	Hardtime	Task	Spec.	Related Documents		
1.		S	MEC	MMS-328 241003 00101 rev 15/05/01		
Check: C						
Zones: 451						
Access:						

NOTE: FILTER REPLACEMENT MUST BE PERFORMED TOGETHER WITH CSD OIL CHANGE REF. MS: 241002 00101

CSD OIL FILTERS REPLACEMENT.

CSD LINE FILTER REPLACEMENT:

1. Remove LINE OIL FILTER.
 - Remove locking wire.
 - Unscrew filter case & discard case O-ring.
 - Remove filter element & discard filter O-ring.
2. Install LINE OIL FILTER.
 - Replace filter O-ring inside mounth of filter element.
 - Replace filter element.
 - Coat filter thread with small amount of VASELINE.
 - Using new case O-ring, install filter case & tighten to 120-360 pound-inches & lockwire.

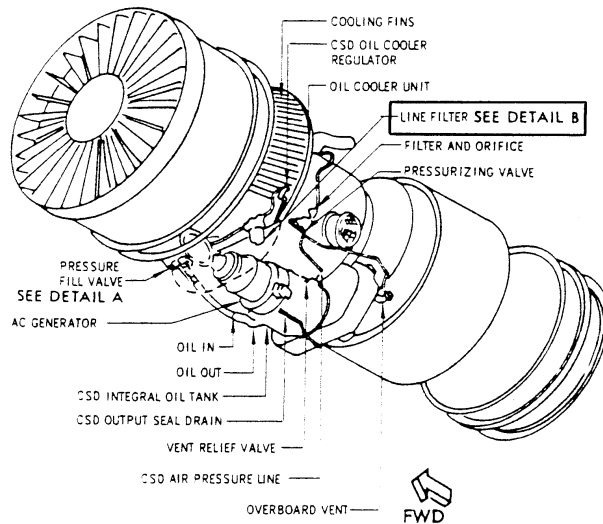
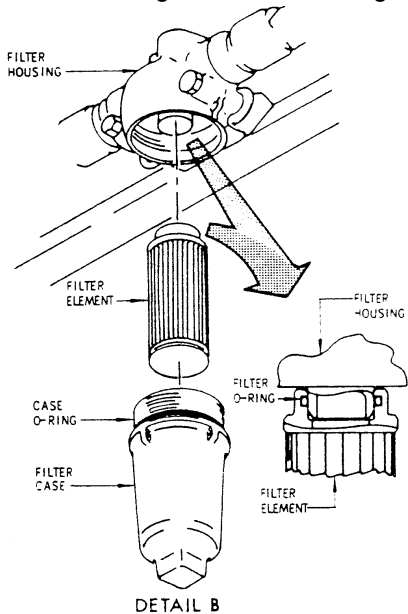

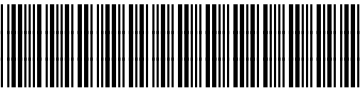
sabena B707	Module: ENGINE 1	A/C Reg :	Check :	 N1H1000504
	Oper. : RT-MP LC			
	Type : SERVICING	Issuer : A43710	Cert.St.: 24828	Page 3 of 3
	Spec. : MECHANIC	Release Date: 17.10.2001		

ENG #1 CSD OIL FILTER REPL

CSD INTEGRAL OIL FILTER REPLACEMENT.

1. Remove INTEGRAL OIL FILTER.

- Remove socket head cap screws & washers from filter cap.
- Remove filter cap & filter cartridge, discarding cap O-ring.
- Separate cartridge from cap.
- Discard the packing O-rings.
- Insert tapered teflon plug or equivalent into opening in ends of dirty filter.
- Clean filter cavity of CSD using lint-free cloth & oil.

2. Install INTEGRAL OIL FILTER.

- Wet the packing O-ring sparingly with ACRYLOID HF825 & install O-ring on filter cartridge.
- Wet the filter cap O-ring sparingly with ACRYLOID HF825 & install O-ring on filter cap.
- Insert filter cartridge in filter cap.
- Insert assembled filter into transmission housing until the flange on the filter cap is in contact with the filter mounting pad.
- Install socket head cap screws & washers, torque to 44-49 pound-inches.

NOTE: AFTER REPLACEMENT OF THE TWO FILTERS, MOTOR ENGINE & CHECK CSD OIL SYSTEM FOR LEAKS.

MAINT	RII/INSP

