



sabena [®] B707	Module: ENGINE 1	A/C Reg :	Check :	 N2F4000504
	Oper. : RT-MP HT			
	Type : NDT INSP	Issuer : A59513	Cert.St.: 46928	
Spec. : NDT INSP	Release Date: 23.11.2005		Page 1 of 4	

MMS-328 544180 03000 ENG 1 STRUT F/S LUGS ULTRASONIC

		MAINT	RII/INSP
Execution / Start Date:			
End Date:			

MMS-328 544180 03000 ENG 1 STRUT F/S LUGS ULTRASONIC

sabena B707	Module: ENGINE 1	A/C Reg :	Check :	 N2F4000504
	Oper. : RT-MP HT	Issuer : A59513	Cert.St.: 46928	
	Type : NDT INSP	Release Date: 23.11.2005	Page 2 of 4	
Spec. : NDT INSP				

MMS-328 544180 03000 **ENG 1 STRUT F/S LUGS ULTRASONIC**

					MAINT	RII/INSP
Nr.	Hardtime	Task	Spec.	Related Documents		
1.	17000 CYC	E4	NDT	AD 85-12-01 R1 rev 5439 MMS-328 544180 03000 rev 15.07.05 SSID 54-A45-04/A rev ..		
Check: 400 CYC						
Zones: 455						
Access:						
NRC YES <input type="radio"/> NO <input type="radio"/>		IF YES, NUMBER(S):				

ENG 1 STRUT F/S FTG LUGS:

CONDITION: OVERWING SUPPORT FITTING FAIRING = REMOVED.

1. STRUT F/S FTG LUGS: ULTRASONIC, INTERNAL: INSPECT THE FITTING LUGS FOR CRACKS. REFER.DOC D6-48023, PART 4, 54-40-07, FIG 1.

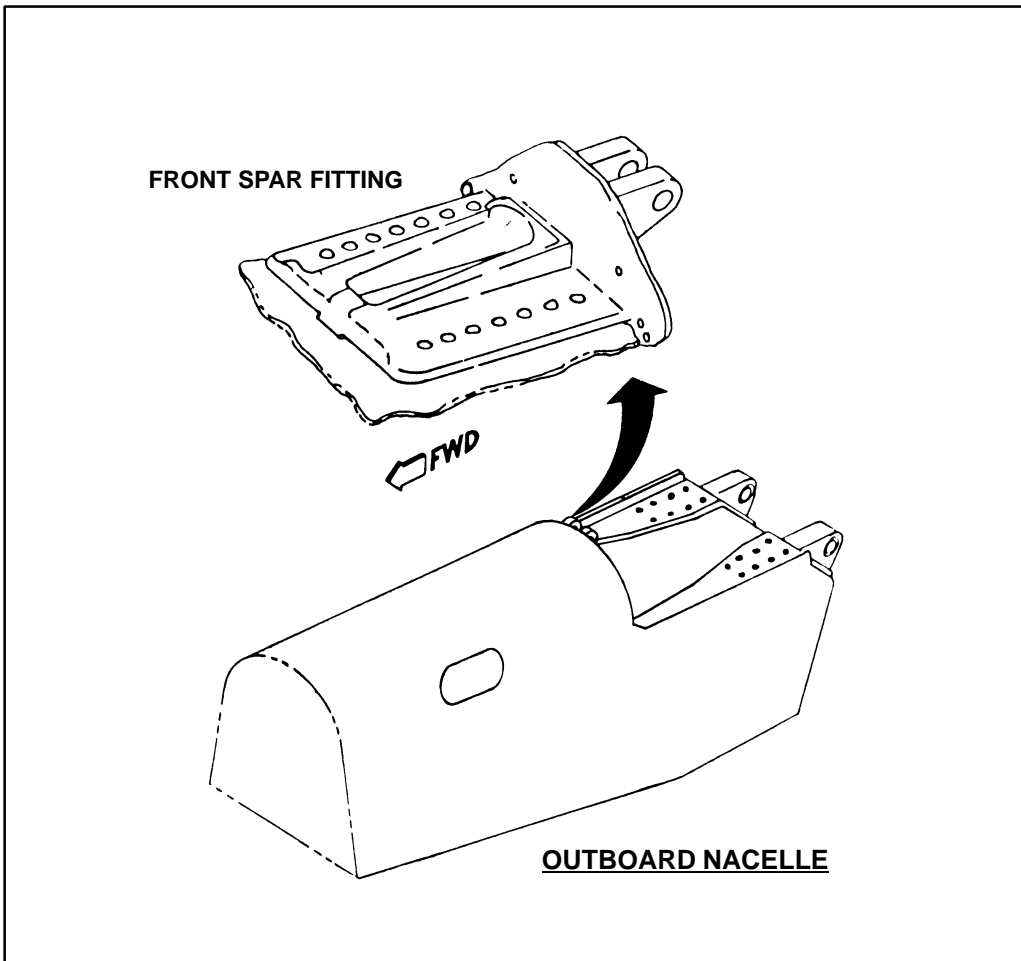

sabena B707	Module: ENGINE 1	A/C Reg :	Check :	 N2F4000504
	Oper. : RT-MP HT			
	Type : NDT INSP	Issuer : A59513	Cert.St.: 46928	Page 3 of 4
Spec. : NDT INSP	Release Date: 23.11.2005			

MMS-328 544180 03000 **ENG 1 STRUT F/S LUGS ULTRASONIC**

					MAINT	RII/INSP
Nr.	Hardtime	Task	Spec.	Related Documents		
2.	17000 CYC	E4	NDT	AD 85-12-01 R1 rev 5439 MMS-328 544180 03000 rev 15.07.05 SSID 54-A45-04/A rev ..		
Check: 400 CYC						
Zones: 455						
Access:						
NRC YES <input type="radio"/> NO <input type="radio"/>		IF YES, NUMBER(S):				

ENG 1 STRUT F/S FTG LUGS:

CONDITION: OVERWING SUPPORT FITTING FAIRING = REMOVED.

1. STRUT F/S FTG LUGS: ULTRASONIC, INTERNAL: INSPECT THE FITTING LUGS FOR CRACKS. REFER.DOC D6-48023, PART 4, 54-40-07, FIG 1.

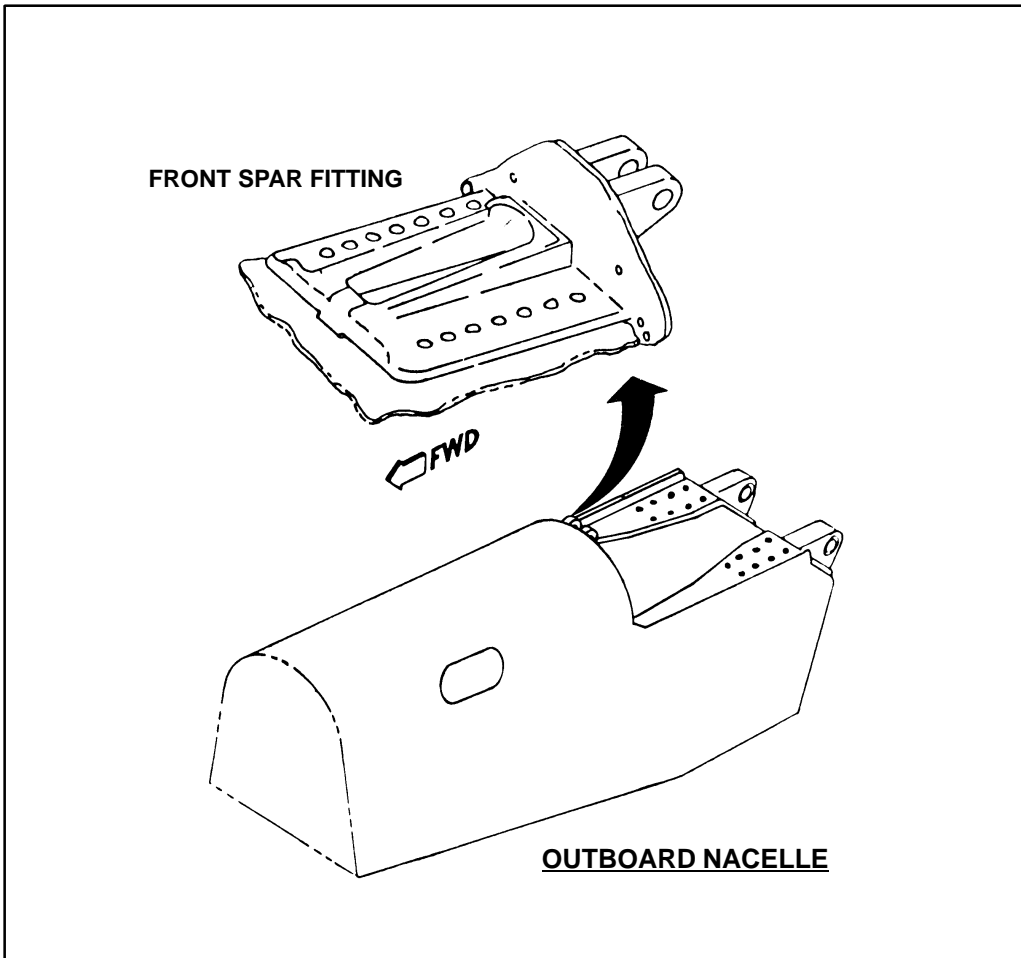

sabena B707	Module: ENGINE 1	A/C Reg :	Check :	 N2F4000504
	Oper. : RT-MP HT	Issuer : A59513	Cert.St.: 46928	
	Type : NDT INSP	Release Date: 23.11.2005	Page 4 of 4	
Spec. : NDT INSP				

MMS-328 544180 03000 **ENG 1 STRUT F/S LUGS ULTRASONIC**

					MAINT	RII/INSP	
Nr.	Hardtime	Task	Spec.	Related Documents			
3.		E4	NDT	AD 85-12-01 R1 rev 5439 MMS-328 544180 03000 rev 15.07.05 SSID 54-A45-04/A rev ..			
Check: 400 CYC							
Zones: 455							
Access:							
NRC YES <input type="radio"/> NO <input type="radio"/>		IF YES, NUMBER(S):					

ENG 1 STRUT F/S FTG LUGS:

CONDITION: OVERWING SUPPORT FITTING FAIRING = REMOVED.

1. STRUT F/S FTG LUGS: ULTRASONIC, INTERNAL: INSPECT THE FITTING LUGS FOR CRACKS. REFER.DOC D6-48023, PART 4, 54-40-07, FIG 1.

