



|   |                          |                 |                 |   |
|---|--------------------------|-----------------|-----------------|---|
| <b>sabena</b> <sup>®</sup><br><b>B707</b> | Module: ENGINE 1         | A/C Reg :       | Check :         | <br><b>N4G2000514</b> |
|   | Oper. : NRT              |                 |                 |   |
|   | Type : MODIF             | Issuer : A47085 | Cert.St.: 46928 |   |
| Spec. : MECH. INSP                        | Release Date: 12.07.2005 |                 | Page 1 of 7     |   |

**SB A3514 rev – FRONT SPAR FITTING–INSPECTION AND REPLACEMENT**

|                         |  | MAINT | RII/INSP |
|-------------------------|--|-------|----------|
| Execution / Start Date: |  |       |          |
| End Date:               |  |       |          |

|                              |                    |                          |                 |   |
|------------------------------|--------------------|--------------------------|-----------------|---|
| <b>sabena</b><br><b>B707</b> | Module: ENGINE 1   | A/C Reg :                | Check :         | <br><b>N4G2000514</b><br><b>Page 2 of 7</b> |
|                              | Oper. : NRT        |                          |                 |   |
|                              | Type : MODIF       | Issuer : A47085          | Cert.St.: 46928 |   |
|                              | Spec. : MECH. INSP | Release Date: 12.07.2005 |                 |   |

**SB A3514 rev – FRONT SPAR FITTING–INSPECTION AND REPLACEMENT**

|                           |          |      |       |                   | MAINT | RII/INSP |
|---------------------------|----------|------|-------|-------------------|-------|----------|
| Nr.                       | Hardtime | Task | Spec. | Related Documents |       |          |
| 1.                        |          |      | INS   | SB A3514 rev –    |       |          |
| <b>Check:</b>             |          |      |       |                   |       |          |
| <b>Zones:</b>             |          |      |       |                   |       |          |
| <b>Access: 1708, 1742</b> |          |      |       |                   |       |          |

**Accomplishment instructions.**

- 1: Install warning tag to not move flap or deactivate following AMM 27–16–202/201
- 2: install warning tag to not move reversers or deactivate following AMM 78–5–0/201
- 3: a) Remove access 1742/1708 LH&RH Nacelle #1–2–3–4 door on left side of the strut nearest to the front spar fitting. Or, if the airplane was manufactured with removable inspection hole caps, see fig 1, remove the inspection hole caps on both side of the strut.  
b) Do a detailed inspection of the upper surface of the front spar fitting as shown in fig 2. If crack are found during inspection, then remove the cracked front spar fitting. Refer to para 2.C of SB A 3514.  
Perform this inspection on nacelle:

–Nacelle 1

|              |
|--------------|
| STAMP FOR OK |
|              |

|                  |
|------------------|
| STAMP FOR NOT OK |
|                  |

|           |
|-----------|
| DR NUMBER |
|           |

–Nacelle 2

|              |
|--------------|
| STAMP FOR OK |
|              |

|                              |                  |                          |                    |   |
|------------------------------|------------------|--------------------------|--------------------|---|
| <b>sabena</b><br><b>B707</b> | Module: ENGINE 1 | A/C Reg :                | Check :            | <br><b>N4G2000514</b> |
|                              | Oper. : NRT      | Issuer : A47085          | Cert.St.: 46928    |   |
|                              | Type : MODIF     | Release Date: 12.07.2005 | <b>Page 3 of 7</b> |   |
| Spec. : MECH. INSP           |                  |                          |                    |   |

**SB A3514 rev - FRONT SPAR FITTING-INSPECTION AND REPLACEMENT**

|   | MAINT | RII/INSP |
|---|-------|----------|
| <p>STAMP FOR NOT OK</p> <p>DR NUMBER</p> <p>-Nacelle 3</p> <p>STAMP FOR OK</p> <p>STAMP FOR NOT OK</p> <p>DR NUMBER</p> <p>-Nacelle 4</p> <p>STAMP FOR OK</p> <p>STAMP FOR NOT OK</p> <p>DR NUMBER</p> <p>4:Install access 1742/1708 LH&amp;RH Nacelle #1-2-3-4 door on left side of the strut nearest to the front spar fitting. Or, if the airplane was manufactured with removable inspection hole caps, see fig 1, install the inspection hole caps on both side of the strut.</p> <p>5: remove warning tag to not move flap or reactivate following AMM 27-16-202/201.</p> |       |          |

|   |                    |                          |                 |  |
|---|--------------------|--------------------------|-----------------|--|
| <b>sabena</b> <sup>®</sup><br><b>B707</b> | Module: ENGINE 1   | A/C Reg :                | Check :         |  |
|   | Oper. : NRT        |                          |                 |  |
|   | Type : MODIF       | Issuer : A47085          | Cert.St.: 46928 | <b>N4G2000514</b>  |
|   | Spec. : MECH. INSP | Release Date: 12.07.2005 |                 | <b>Page 4 of 7</b>   |

**SB A3514 rev – FRONT SPAR FITTING–INSPECTION AND REPLACEMENT**

|   | MAINT | RII/INSP |
|---|-------|----------|
| 6: Remove warning tag to not move reversers or reactivate following AMM 78-5-0/201. |       |          |
| 7: Put airplane back to a serviceable configuration.                                |       |          |
| 8: Fill accomplishment report and attach it to CDLR30 (DLM report)..                |       |          |

|                       |                  |                          |                    |   |
|-----------------------|------------------|--------------------------|--------------------|---|
| <b>sabena</b><br>B707 | Module: ENGINE 1 | A/C Reg :                | Check :            | <br><b>N4G2000514</b> |
|                       | Oper. : NRT      | Issuer : A47085          | Cert.St.: 46928    |   |
|                       | Type : MODIF     | Release Date: 12.07.2005 | <b>Page 5 of 7</b> |   |
| Spec. : MECH. INSP    |                  |                          |                    |   |

SB A3514 rev - FRONT SPAR FITTING-INSPECTION AND REPLACEMENT

MAINT RII/INSP

**BOEING SERVICE BULLETIN A3514**

**ALERT**

**FRONT SPAR FITTING - ALL NACELLES**

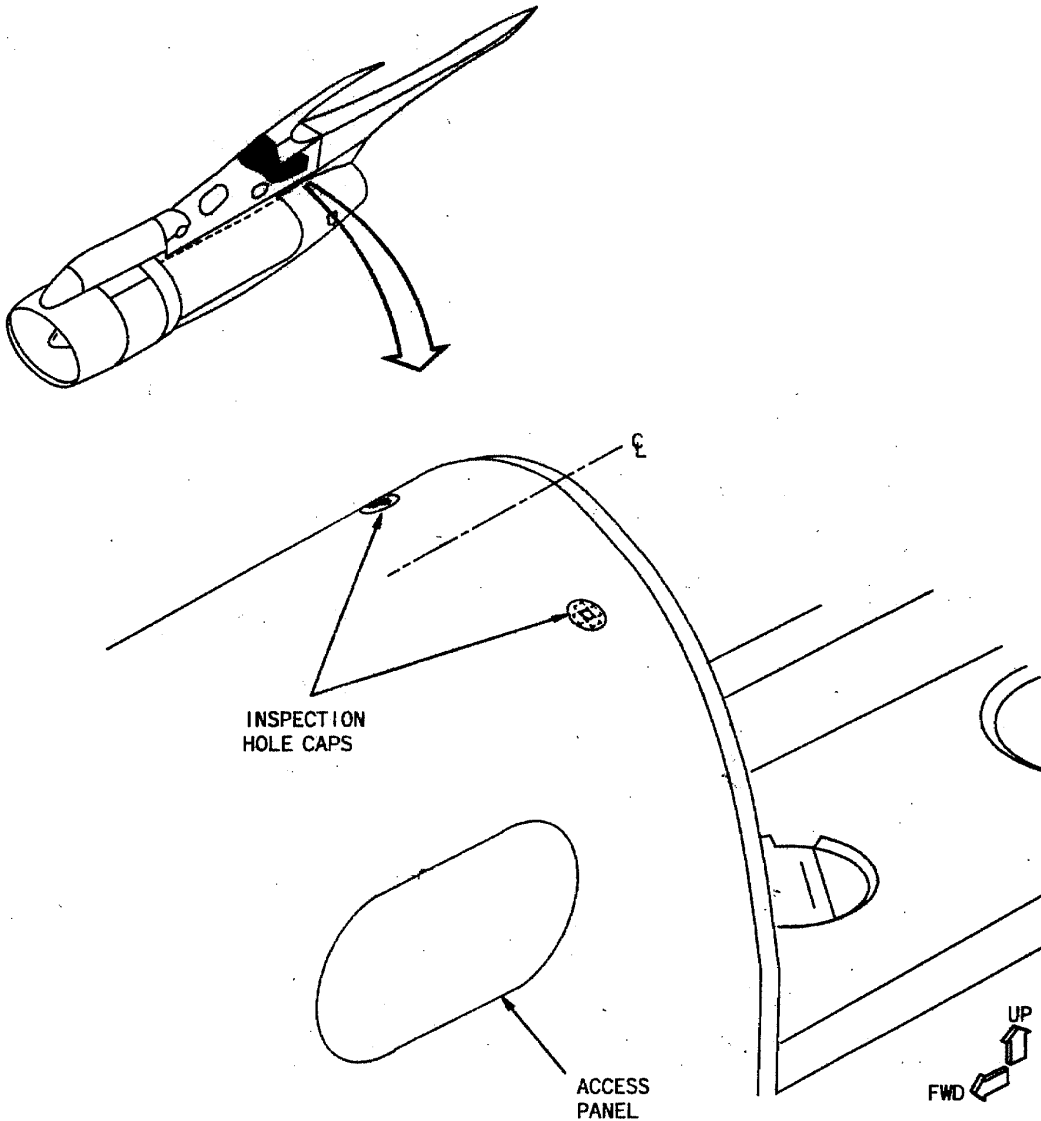

**FIGURE 1: NACELLE ACCESS - FRONT SPAR FITTING - ALL NACELLES  
(SHEET 1 OF 1)**

July 29, 2004

A3514

SB A3514 rev - FRONT SPAR FITTING-INSPECTION AND REPLACEMENT

|                              |                          |                 |                 |   |
|------------------------------|--------------------------|-----------------|-----------------|---|
| <b>sabena</b><br><b>B707</b> | Module: ENGINE 1         | A/C Reg :       | Check :         | <br><b>N4G2000514</b> |
|                              | Oper. : NRT              |                 |                 |   |
|                              | Type : MODIF             | Issuer : A47085 | Cert.St.: 46928 | <b>Page 6 of 7</b>  |
| Spec. : MECH. INSP           | Release Date: 12.07.2005 |                 |                 |   |

SB A3514 rev – FRONT SPAR FITTING–INSPECTION AND REPLACEMENT

MAINT RII/INSP

**BOEING SERVICE BULLETIN A3514**

**ALERT**

**ALERT**

**FIGURE 2: NACELLE NUMBER 1 - FRONT SPAR FITTING - INSPECTION**

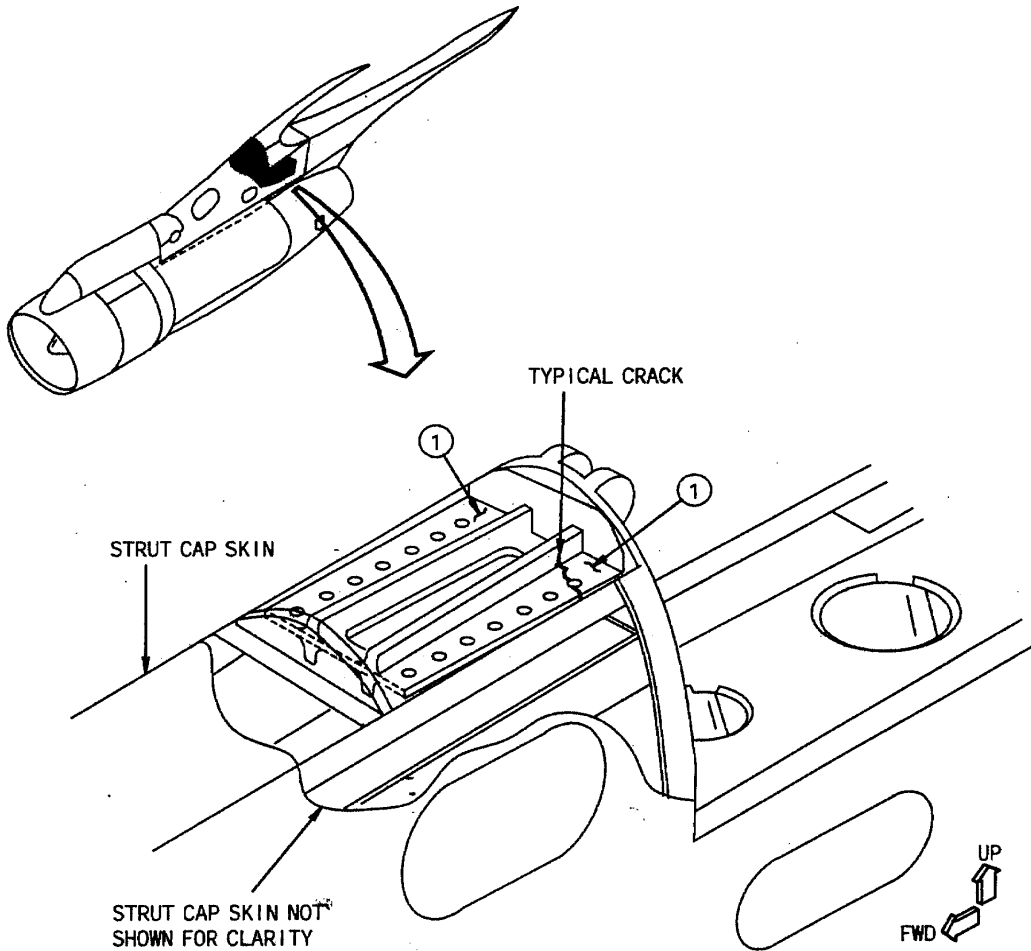

The step numbers shown below agree with the numbers shown in the circle symbols in the figure.

| STEP | TASK    | NAME               | PROCEDURE           | REFERENCES | MORE DATA |
|------|---------|--------------------|---------------------|------------|-----------|
| 1    | Inspect | Front Spar Fitting | Detailed Inspection | -          | (a)       |

(a) Do a detailed inspection of the upper surface of the front spar fitting. Pay particular attention to the front spar fitting surface around the fasteners.

**FIGURE 2: NACELLE NUMBER 1 - FRONT SPAR FITTING - INSPECTION**  
(SHEET 1 OF 1)

July 29, 2004

A3514

|                       |                    |                          |                 |  |                 |
|-----------------------|--------------------|--------------------------|-----------------|--|-----------------|
| <b>sabena</b><br>B707 | Module: ENGINE 1   | A/C Reg :                | Check :         | <br><b>N4G2000514</b><br>Page 7 of 7 |                 |
|                       | Oper. : NRT        | Type : MODIF             | Issuer : A47085 |  | Cert.St.: 46928 |
|                       | Spec. : MECH. INSP | Release Date: 12.07.2005 |                 |  |                 |

SB A3514 rev - FRONT SPAR FITTING-INSPECTION AND REPLACEMENT

MAINT RII/INSP

|  |   |  |
|--|---|--|
|  | TAMCO SORL ITALY/TOM A/ESSE<br><b>ENGINEERING INSTRUCTION</b> | NR. 030<br>Ref.:<br>Revision:<br>Rev. Date:<br>ATA chap.: 54<br>Date: 18.10.2004<br>Page: 9 of 9 |
|--|---|--|

**Accomplishment Report**

**Subject:** Nacelles - Nacelle Strut- Front Spar Fitting- Inspection and Replacement

**Model:** B707

**Accomplished at (Tailnumber):**

**Date of Accomplishment:**

**Description of Deviations:**

**Findings:**

**Carry Overs:**

**SOR Statements:**

Attach this Accomplishment Report to CDRL30 (DLM Report)

|   |  |   |
|---|--|---|
| <b>Executed/performed by:</b><br>Name:<br>Signature:<br>Date:<br>SOR: | <b>SOR Engineering Representative:</b><br>Name:<br>Signature:<br>Date: | <b>SOR Quality Assurance:</b><br>Name:<br>Signature:<br>Date: |
|---|--|---|

SB A3514 rev - FRONT SPAR FITTING-INSPECTION AND REPLACEMENT