



sabena [®] B707	Module: ENGINE 2	A/C Reg :	Check :	 O1F3000502
	Oper. : RT-MP LC			
	Type : STRUCT-INSP	Issuer : A43710	Cert.St.: 24828	Page 1 of 2
Spec. : MECH. INSP	Release Date: 16.10.2001			

ENG#2 NOSE COWL SEC AIR INL DOOR INSP

Execution / Start Date:	
End Date:	

MAINT	RII/INSP

sabena B707	Module: ENGINE 2	A/C Reg :	Check :	 O1F3000502
	Oper. : RT-MP LC	Issuer : A43710	Cert.St.: 24828	
	Type : STRUCT-INSP	Release Date: 16.10.2001	Page 2 of 2	
Spec. : MECH. INSP				

ENG#2 NOSE COWL SEC AIR INL DOOR INSP

					MAINT	RII/INSP
Nr.	Hardtime	Task	Spec.	Related Documents		
1.		E3	INS	CPM 54-10-07 rev . MMS-328 541210 02000 rev 15/05/01 MPD 4-71-4 rev .		
Check: C1						
Zones: 452						
Access:						

ENGINE #2 NOSE COWL SECONDARY AIR INLET DOORS INSPECTION.

Perform inspection of nose cowl secondary air inlet doors. Inspect skin in vicinity of air inlet doors for deterioration of finish and evidence of corrosion.

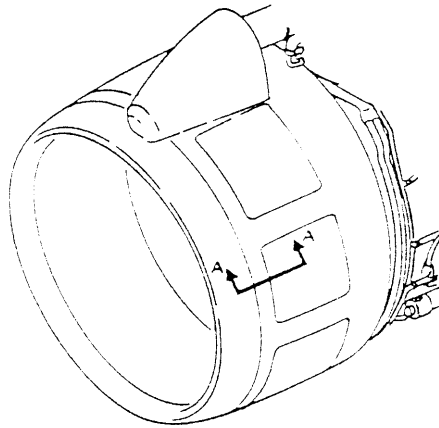

NOSE COWL WITH LARGE SECONDARY AIR INLET DOORS

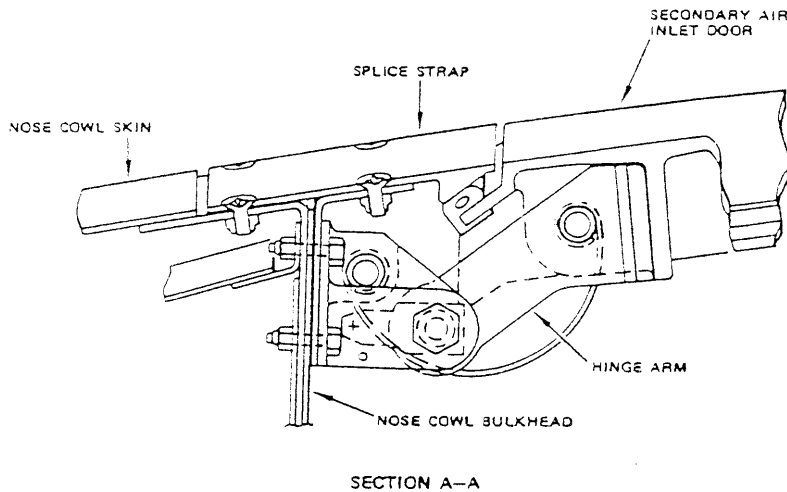

Nose Cowl Secondary Air Inlet Door Hinges
Figure 2 (Sheet 1)