

sabena [®] B707	Module: ENGINE 4	A/C Reg :	Check :	 Q2F4000504
	Oper. : RT-MP HT			
	Type : NDT INSP	Issuer : A45559	Cert.St.: 46928	
Spec. : NDT INSP	Release Date: 13.12.2006		Page 1 of 4	

MMS-328 544480 03000

ENG 4 STRUT F/S LUGS ULTRASONIC

		MAINT	RII/INSP
Execution / Start Date:			
End Date:			

MMS-328 544480 03000

ENG 4 STRUT F/S LUGS ULTRASONIC

sabena B707	Module: ENGINE 4	A/C Reg :	Check :	 Q2F4000504
	Oper. : RT-MP HT			
	Type : NDT INSP	Issuer : A45559	Cert.St.: 46928	Page 2 of 4
Spec. : NDT INSP	Release Date: 13.12.2006			

MMS-328 544480 03000 **ENG 4 STRUT F/S LUGS ULTRASONIC**

					MAINT	RII/INSP	
Nr.	Hardtime	Task	Spec.	Related Documents			
1.	17000 CYC	E4	NDT	AD 85-12-01 R1 rev 5439 MMS-328 544480 03000 rev 15.07.05 SSID 54-A45-04/A rev N			
Check: 400 CYC							
Zones: 458							
Access:							
NRC YES <input type="radio"/> NO <input type="radio"/>		IF YES, NUMBER(S):					

ENG 4 STRUT F/S FTG LUGS:

CONDITION: OVERWING SUPPORT FITTING FAIRING = REMOVED.

1. STRUT F/S FTG LUGS: ULTRASONIC, INTERNAL: INSPECT THE FITTING LUGS FOR
CRACKS.REFER.DOC D6-48023,PART 4,54-40-07,FIG1.

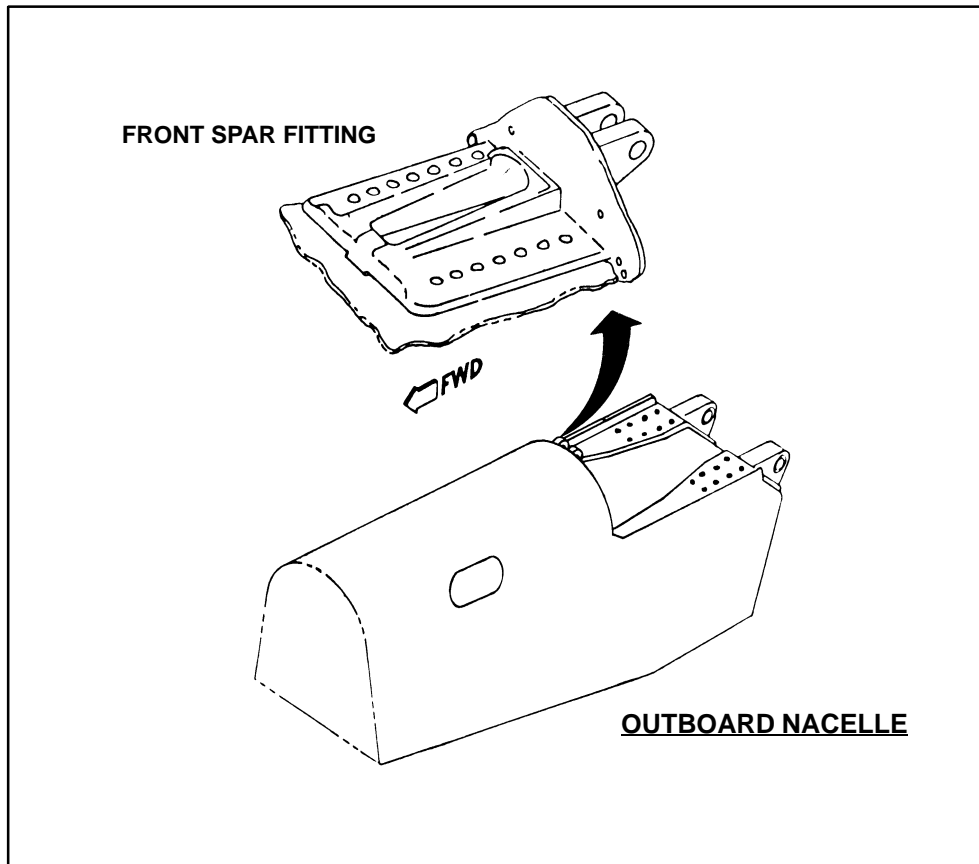

sabena B707	Module: ENGINE 4	A/C Reg :	Check :	 Q2F4000504
	Oper. : RT-MP HT	Issuer : A45559	Cert.St.: 46928	
	Type : NDT INSP	Release Date: 13.12.2006	Page 3 of 4	
Spec. : NDT INSP				

MMS-328 544480 03000 **ENG 4 STRUT F/S LUGS ULTRASONIC**

					MAINT	RII/INSP	
Nr.	Hardtime	Task	Spec.	Related Documents			
2.	17000 CYC	E4	NDT	AD 85-12-01 R1 rev 5439 MMS-328 544480 03000 rev 15.07.05 SSID 54-A45-04/A rev N			
Check: 400 CYC							
Zones: 458							
Access:							
NRC YES <input type="radio"/> NO <input type="radio"/>		IF YES, NUMBER(S):					

ENG 4 STRUT F/S FTG LUGS:

CONDITION: OVERWING SUPPORT FITTING FAIRING = REMOVED.

1. STRUT F/S FTG LUGS: ULTRASONIC, INTERNAL: INSPECT THE FITTING LUGS FOR CRACKS.REFER.DOC D6-48023,PART 4,54-40-07,FIG1.

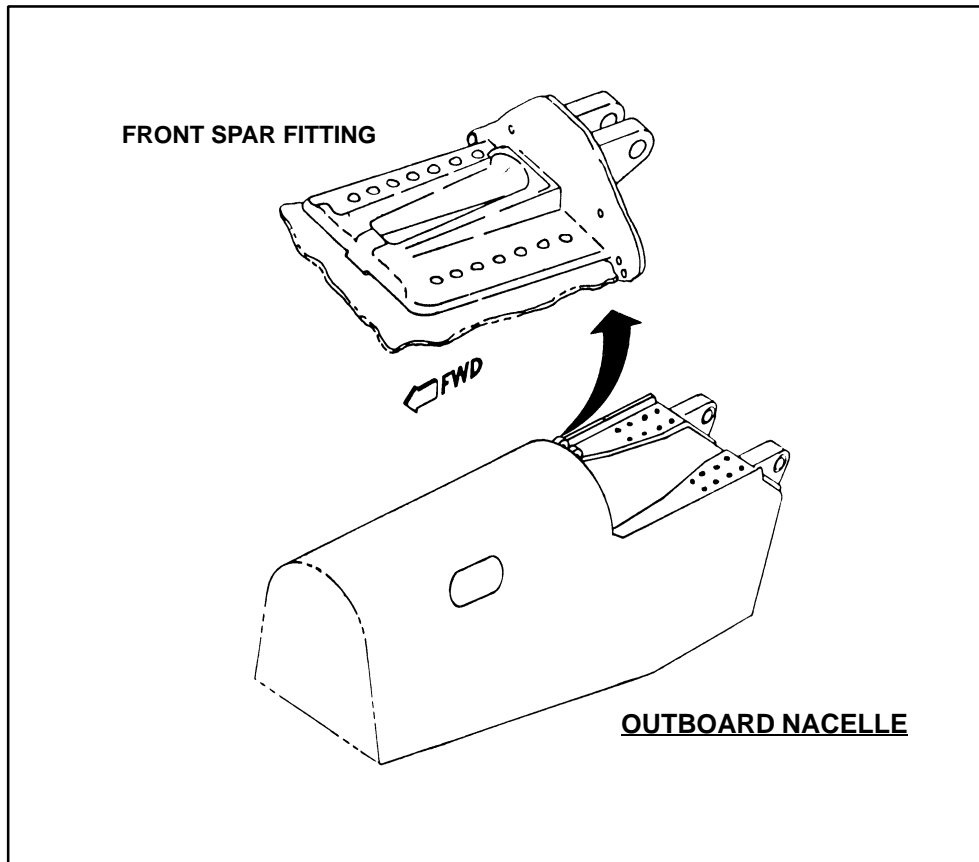

sabena B707	Module: ENGINE 4	A/C Reg :	Check :	 Q2F4000504
	Oper. : RT-MP HT			
	Type : NDT INSP	Issuer : A45559	Cert.St.: 46928	Page 4 of 4
Spec. : NDT INSP	Release Date: 13.12.2006			

MMS-328 544480 03000 **ENG 4 STRUT F/S LUGS ULTRASONIC**

					MAINT	RII/INSP
Nr.	Hardtime	Task	Spec.	Related Documents		
3.		E4	NDT	AD 85-12-01 R1 rev 5439 MMS-328 544480 03000 rev 15.07.05 SSID 54-A45-04/A rev N		
Check: 400 CYC						
Zones: 458						
Access:						
NRC YES <input type="radio"/> NO <input type="radio"/>		IF YES, NUMBER(S):				

ENG 4 STRUT F/S FTG LUGS:

CONDITION: OVERWING SUPPORT FITTING FAIRING = REMOVED.

1. STRUT F/S FTG LUGS: ULTRASONIC, INTERNAL: INSPECT THE FITTING LUGS FOR
CRACKS.REFER.DOC D6-48023,PART 4,54-40-07,FIG1.

