



|                              |                          |                 |                 |   |
|------------------------------|--------------------------|-----------------|-----------------|---|
| <b>sabena</b><br><b>B707</b> | Module: PYLON 1          | A/C Reg :       | Check :         | <br><b>S1F3000502</b> |
|                              | Oper. : RT-MP LC         |                 |                 |   |
|                              | Type : STRUCT-INSP       | Issuer : A59513 | Cert.St.: 46928 | <b>Page 1 of 4</b>  |
| Spec. : MECH. INSP           | Release Date: 22.11.2005 |                 |                 |   |

**NACELLE STRUT # 1 STRUCT EXTERNAL INSP**

|                         |  |
|-------------------------|--|
| Execution / Start Date: |  |
| End Date:               |  |

| MAINT | RII/INSP |
|-------|----------|
|       |          |

|                              |                    |                          |                 |  |
|------------------------------|--------------------|--------------------------|-----------------|--|
| <b>sabena</b><br><b>B707</b> | Module: PYLON 1    | A/C Reg :                | Check :         | <br><b>S1F3000502</b><br>Page 2 of 4 |
|                              | Oper. : RT-MP LC   | Issuer : A59513          | Cert.St.: 46928 |  |
|                              | Type : STRUCT-INSP | Release Date: 22.11.2005 |                 |  |
| Spec. : MECH. INSP           |                    |                          |                 |  |

**NACELLE STRUT # 1 STRUCT EXTERNAL INSP**

|  |           |                    |       |  | MAINT | RII/INSP |
|--|-----------|--------------------|-------|--|-------|----------|
| Nr.  | Hardtime  | Task               | Spec. | Related Documents  |       |          |
| 1.   | 19000 CYC | E3                 | INS   | AD 85-12-01 R1 rev 5439<br>MMS-328 541170 01001 rev 15.07.05<br>SSID 54-A40-03/A rev . |       |          |
| <b>Check:</b> B  |           |                    |       |  |       |          |
| <b>Zones:</b> 455                                      |           |                    |       |  |       |          |
| <b>Access:</b>   |           |                    |       |  |       |          |
| NRC YES <input type="radio"/> NO <input type="radio"/> |           | IF YES, NUMBER(S): |       |  |       |          |

**NACELLE / STRUT # 1 STRUCTURE:**

**CLOSE VISUAL, EXTERNAL:**

Inspect for cracks in nacelle strut skin, paying particular attention to the areas adjacent to the SPARS, BULKHEADS, RIBS & especially near the STRUT & ENG SUPPORT FITTINGS.

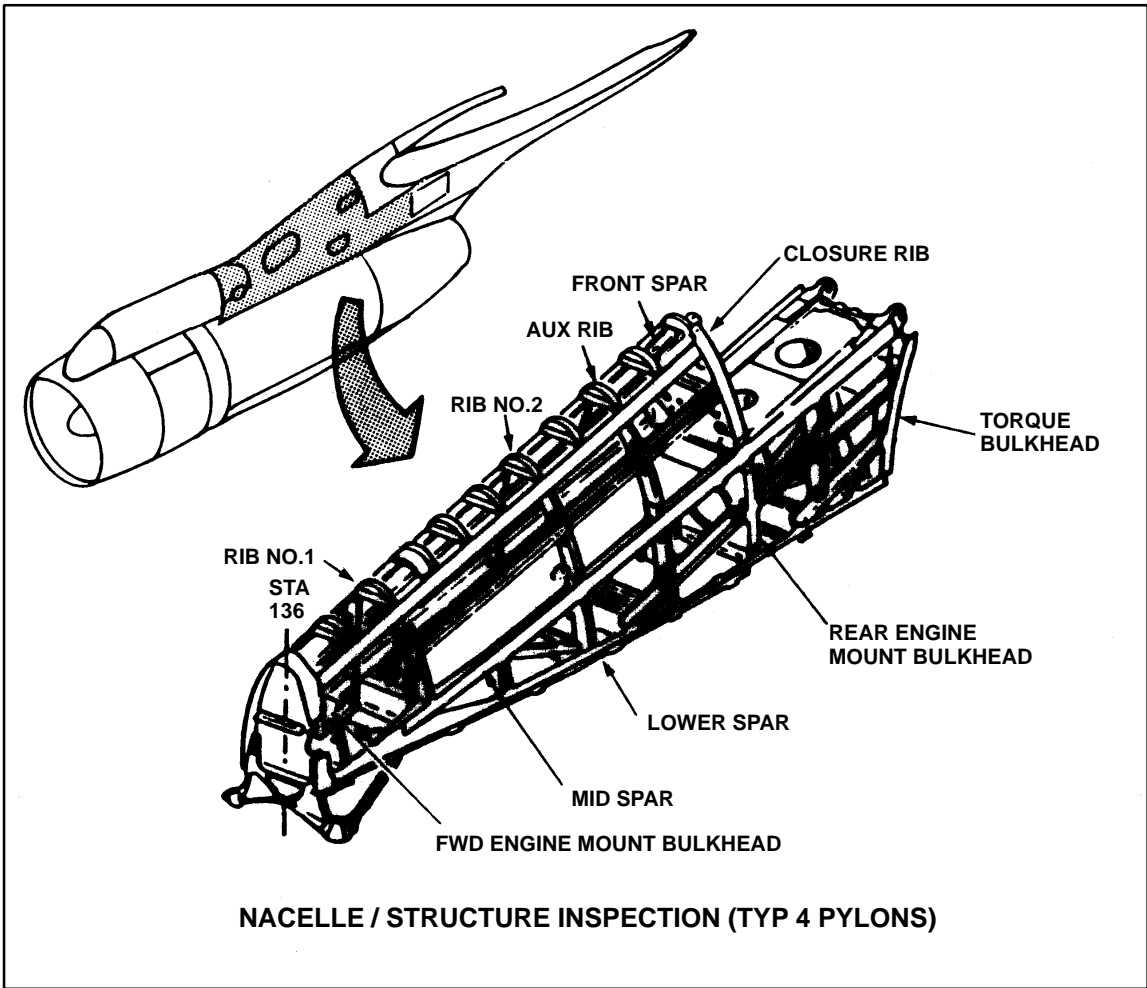

|                       |                    |                          |                 |  |
|-----------------------|--------------------|--------------------------|-----------------|--|
| <b>sabena</b><br>B707 | Module: PYLON 1    | A/C Reg :                | Check :         | <br><b>S1F3000502</b><br>Page 3 of 4 |
|                       | Oper. : RT-MP LC   | Issuer : A59513          | Cert.St.: 46928 |  |
|                       | Type : STRUCT-INSP | Release Date: 22.11.2005 |                 |  |
| Spec. : MECH. INSP    |                    |                          |                 |  |

**NACELLE STRUT # 1 STRUCT EXTERNAL INSP**

|  |          |                    |       |  | MAINT | RII/INSP |  |
|--|----------|--------------------|-------|--|-------|----------|--|
| Nr.  | Hardtime | Task               | Spec. | Related Documents  |       |          |  |
| 2.   |          | E3                 | INS   | AD 85-12-01 R1 rev 5439<br>MMS-328 541170 01001 rev 15.07.05<br>SSID 54-A40-03/A rev . |       |          |  |
| Check: B   |          |                    |       |  |       |          |  |
| Zones: 455   |          |                    |       |  |       |          |  |
| Access:  |          |                    |       |  |       |          |  |
| NRC YES <input type="radio"/> NO <input type="radio"/> |          | IF YES, NUMBER(S): |       |  |       |          |  |

**NACELLE / STRUT # 1 STRUCTURE:**

**CLOSE VISUAL, EXTERNAL:**

Inspect for cracks in nacelle strut skin, paying particular attention to the areas adjacent to the SPARS, BULKHEADS, RIBS & especially near the STRUT & ENG SUPPORT FITTINGS.

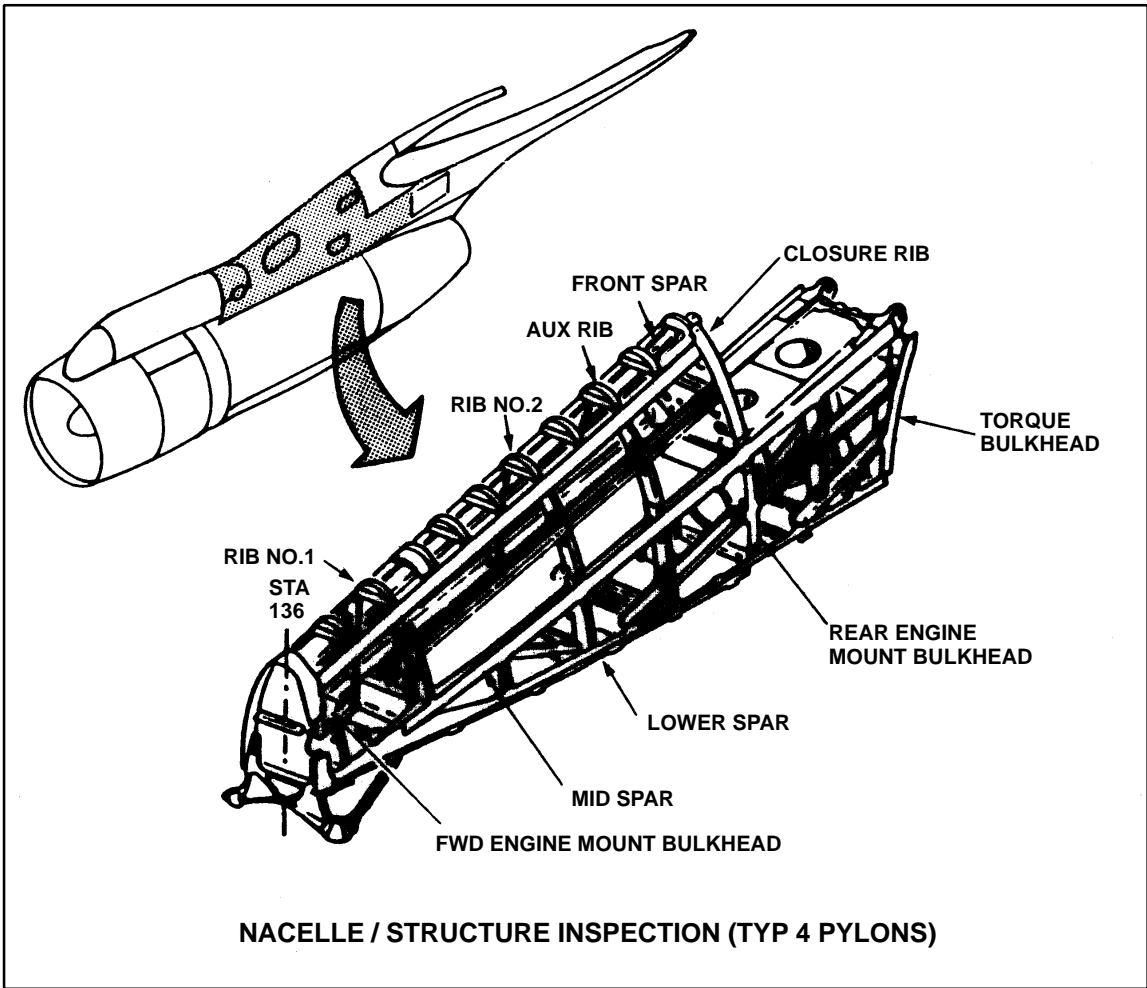

**NACELLE / STRUCTURE INSPECTION (TYP 4 PYLONS)**

|                              |                    |                          |                 |   |
|------------------------------|--------------------|--------------------------|-----------------|---|
| <b>sabena</b><br><b>B707</b> | Module: PYLON 1    | A/C Reg :                | Check :         | <br><b>S1F3000502</b><br><b>Page 4 of 4</b> |
|                              | Oper. : RT-MP LC   | Issuer : A59513          | Cert.St.: 46928 |   |
|                              | Type : STRUCT-INSP | Release Date: 22.11.2005 |                 |   |
| Spec. : MECH. INSP           |                    |                          |                 |   |

**NACELLE STRUT # 1 STRUCT EXTERNAL INSP**

|  |           |                    |       |  | MAINT | RII/INSP |  |
|--|-----------|--------------------|-------|--|-------|----------|--|
| Nr.  | Hardtime  | Task               | Spec. | Related Documents  |       |          |  |
| 3.   | 19000 CYC | E3                 | INS   | AD 85-12-01 R1 rev 5439<br>MMS-328 541170 01001 rev 15.07.05<br>SSID 54-A40-03/A rev . |       |          |  |
| <b>Check:</b> B  |           |                    |       |  |       |          |  |
| <b>Zones:</b> 455                                      |           |                    |       |  |       |          |  |
| <b>Access:</b>   |           |                    |       |  |       |          |  |
| NRC YES <input type="radio"/> NO <input type="radio"/> |           | IF YES, NUMBER(S): |       |  |       |          |  |

**NACELLE / STRUT # 1 STRUCTURE:**

**CLOSE VISUAL. EXTERNAL:**

Inspect for cracks in nacelle strut skin, paying particular attention to the areas adjacent to the SPARS, BULKHEADS, RIBS & especially near the STRUT & ENG SUPPORT FITTINGS.

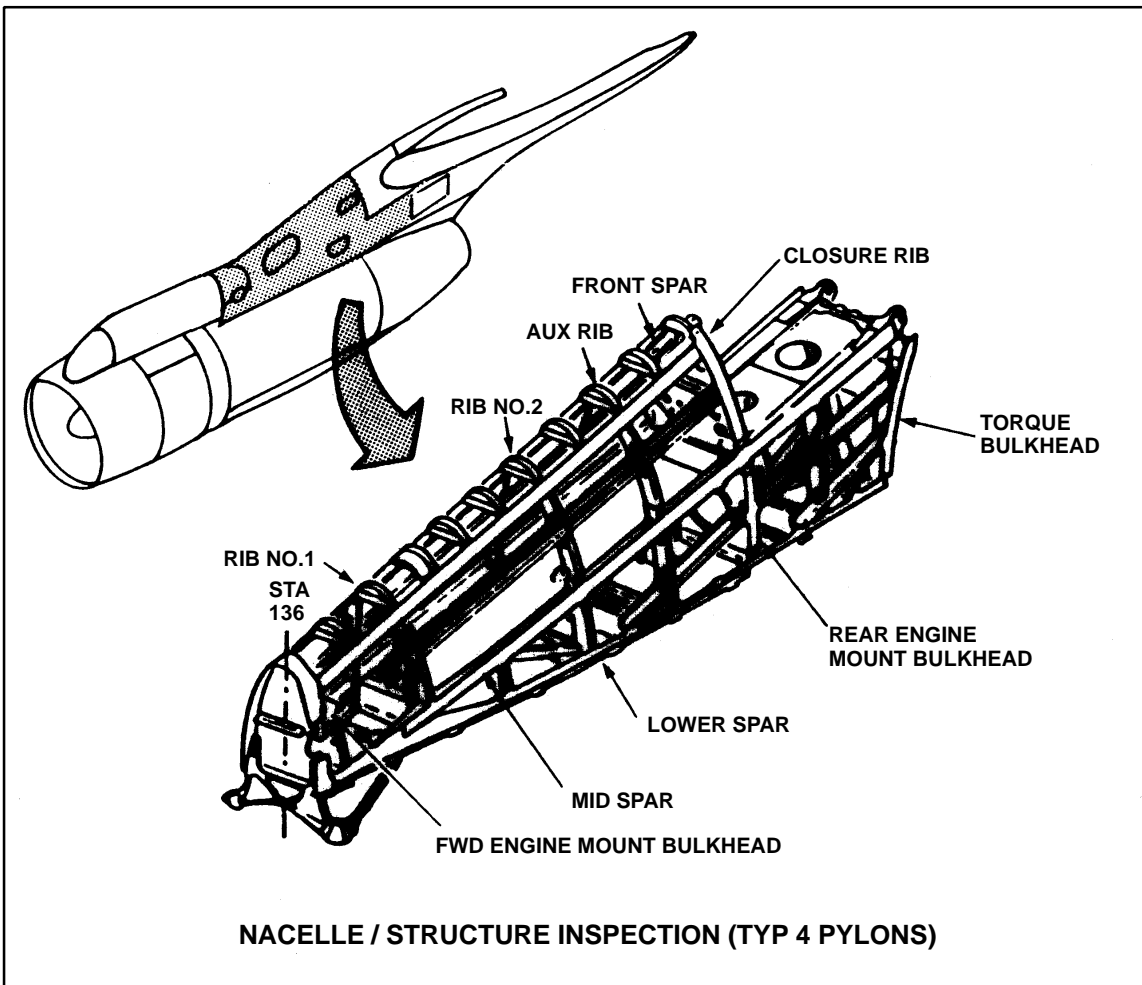

**NACELLE / STRUCTURE INSPECTION (TYP 4 PYLONS)**