



sabena [®] B707	Module: PYLON 2	A/C Reg :	Check :	 T1F2000505
	Oper. : RT-MP LC			
	Type : MEC-INSP	Issuer : A59513	Cert.St.: 46928	Page 1 of 4
Spec. : MECH. INSP	Release Date: 28.06.2006			

NACELLE 2 FRONT SPAR FITTING INSP

Execution / Start Date:	
End Date:	

MAINT	RII/INSP

sabena B707	Module: PYLON 2	A/C Reg :	Check :	 T1F2000505 Page 2 of 4
	Oper. : RT-MP LC			
	Type : MEC-INSP	Issuer : A59513	Cert.St.: 46928	
	Spec. : MECH. INSP	Release Date: 28.06.2006		

NACELLE 2 FRONT SPAR FITTING INSP

					MAINT	RII/INSP
Nr.	Hardtime	Task	Spec.	Related Documents		
1.		E3	INS	MMS-328 541250 01000 rev 05.11.04 SB A3514 rev -		
Check: C						
Zones: 456						
Access: 1708						
NRC YES <input type="radio"/> NO <input type="radio"/>		IF YES, NUMBER(S):				

CLOSE VISUAL INSPECTION NACELLE 2 FRONT SPAR FITTING

1. Install warning tag to not move flap or deactivate following AMM 27-16-202/201
2. install warning tag to not move reversers or deactivate following AMM 78-5-0/201
3. Remove access 1742/1708 LH &RH Nacelle #2 door on LH side of the strut nearest to the front spar fitting. Or, if the airplane was manufactured with removable inspection hole caps, see fig 1, remove the inspection hole caps on both side of the strut.
4. Do a CLOSE VISUAL INSPECTION of upper surface of front spar fitting for cracks, damage failure or irregularity as shown in fig 2.
5. Install access 1742/1708 LH&RH Nacelle #2 door on left side of the strut nearest to the front spar fitting. Or, if the airplane was manufactured with removable inspection hole caps, see fig 1, install the inspection hole caps on both side of the strut.
6. Remove warning tag to not move flap or reactivate following AMM 27-16-202/201.
7. Remove warning tag to not move reversers or reactivate following AMM 78-5-0/201.
8. Put airplane back to a serviceable configuration.

sabena B707	Module: PYLON 2	A/C Reg :	Check :	
	Oper. : RT-MP LC			
	Type : MEC-INSP	Issuer : A59513	Cert.St.: 46928	T1F2000505
	Spec. : MECH. INSP	Release Date: 28.06.2006		Page 3 of 4

NACELLE 2 FRONT SPAR FITTING INSP

BOEING SERVICE BULLETIN A3514

ALERT

FRONT SPAR FITTING - ALL NACELLES

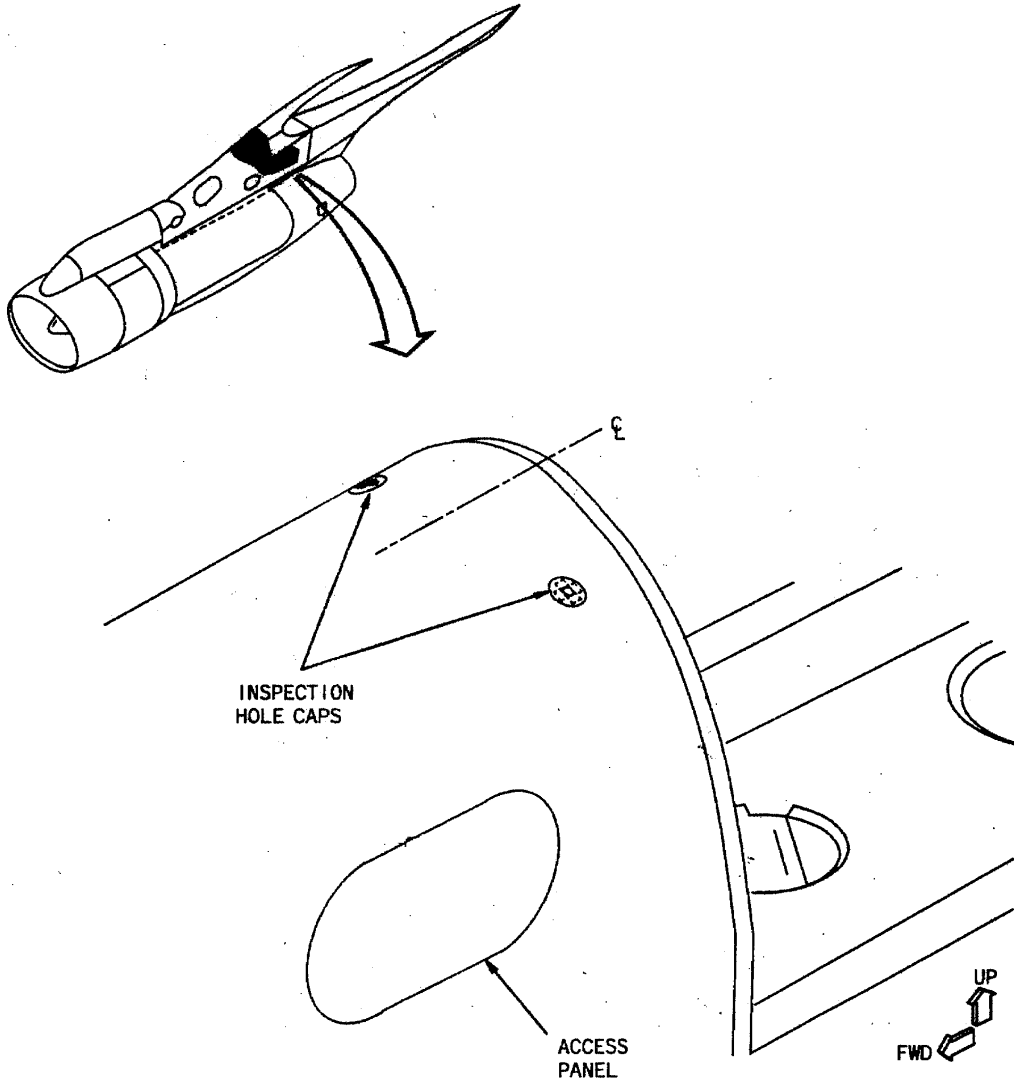



FIGURE 1: NACELLE ACCESS - FRONT SPAR FITTING - ALL NACELLES (SHEET 1 OF 1)

July 29, 2004

A3514

MAINT	RII/INSP

sabena B707	Module: PYLON 2	A/C Reg :	Check :	 T1F2000505 Page 4 of 4
	Oper. : RT-MP LC			
	Type : MEC-INSP	Issuer : A59513	Cert.St.: 46928	
	Spec. : MECH. INSP	Release Date: 28.06.2006		

NACELLE 2 FRONT SPAR FITTING INSP

MAINT RII/INSP

BOEING SERVICE BULLETIN A3514

ALERT

ALERT

FIGURE 2: NACELLE NUMBER 1 - FRONT SPAR FITTING - INSPECTION

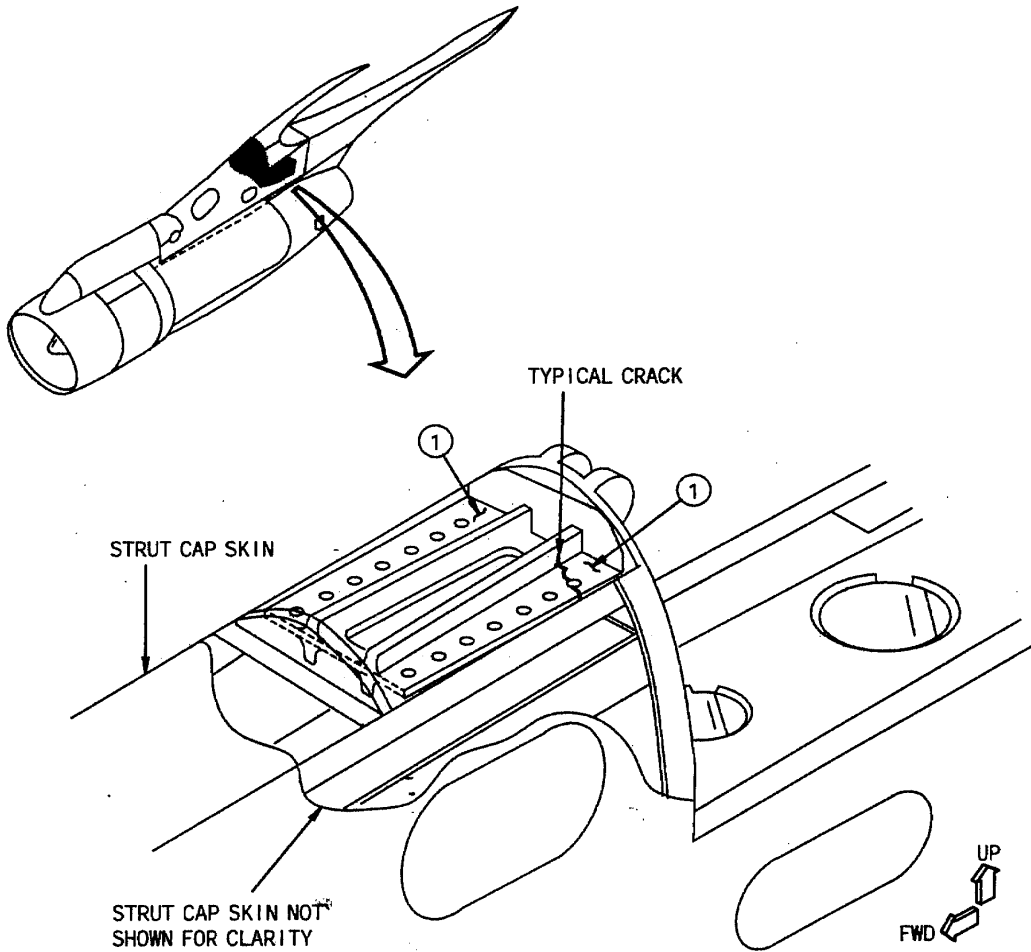

The step numbers shown below agree with the numbers shown in the circle symbols in the figure.

STEP	TASK	NAME	PROCEDURE	REFERENCES	MORE DATA
1	Inspect	Front Spar Fitting	Detailed Inspection	-	(a)
(a) Do a detailed inspection of the upper surface of the front spar fitting. Pay particular attention to the front spar fitting surface around the fasteners.					

FIGURE 2: NACELLE NUMBER 1 - FRONT SPAR FITTING - INSPECTION

July 29, 2004

(SHEET 1 OF 1)

A3514