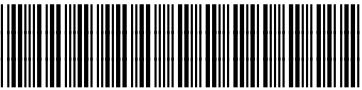
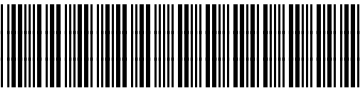

<b>sabena</b> <sup>®</sup> <b>B707</b>	Module: PYLON 3	A/C Reg :	Check :	 <b>U1F3000504</b>
	Oper. : RT-MP LC			
	Type : STRUCT-INSP	Issuer : A59513	Cert.St.: 46928	<b>Page 1 of 4</b>
Spec. : MECH. INSP	Release Date: 23.11.2005			

**NACELLE STRUT # 3 STRUCT EXTERNAL INSP**

Execution / Start Date:	
End Date:	

MAINT	RII/INSP

<b>sabena</b> <b>B707</b>	Module: PYLON 3	A/C Reg :	Check :	 <b>U1F3000504</b>
	Oper. : RT-MP LC	Issuer : A59513	Cert.St.: 46928	
	Type : STRUCT-INSP	Release Date: 23.11.2005	<b>Page 2 of 4</b>	
Spec. : MECH. INSP				

**NACELLE STRUT # 3 STRUCT EXTERNAL INSP**

					MAINT	RII/INSP
Nr.	Hardtime	Task	Spec.	Related Documents		
1.	19000 CYC	E3	INS	AD 85-12-01 R1 rev 5439 MMS-328 541370 01001 rev 15.07.05 SSID 54-A40-03/A rev .		
Check: B						
Zones: 457						
Access:						
NRC YES <input type="radio"/> NO <input type="radio"/>		IF YES, NUMBER(S):				

**NACELLE / STRUT # 3 STRUCTURE:**

**CLOSE VISUAL, EXTERNAL:**

Inspect for cracks in nacelle strut skin, paying particular attention to the areas adjacent to the SPARS, BULKHEADS, RIBS & especially near the STRUT & ENG SUPPORT FITTINGS.

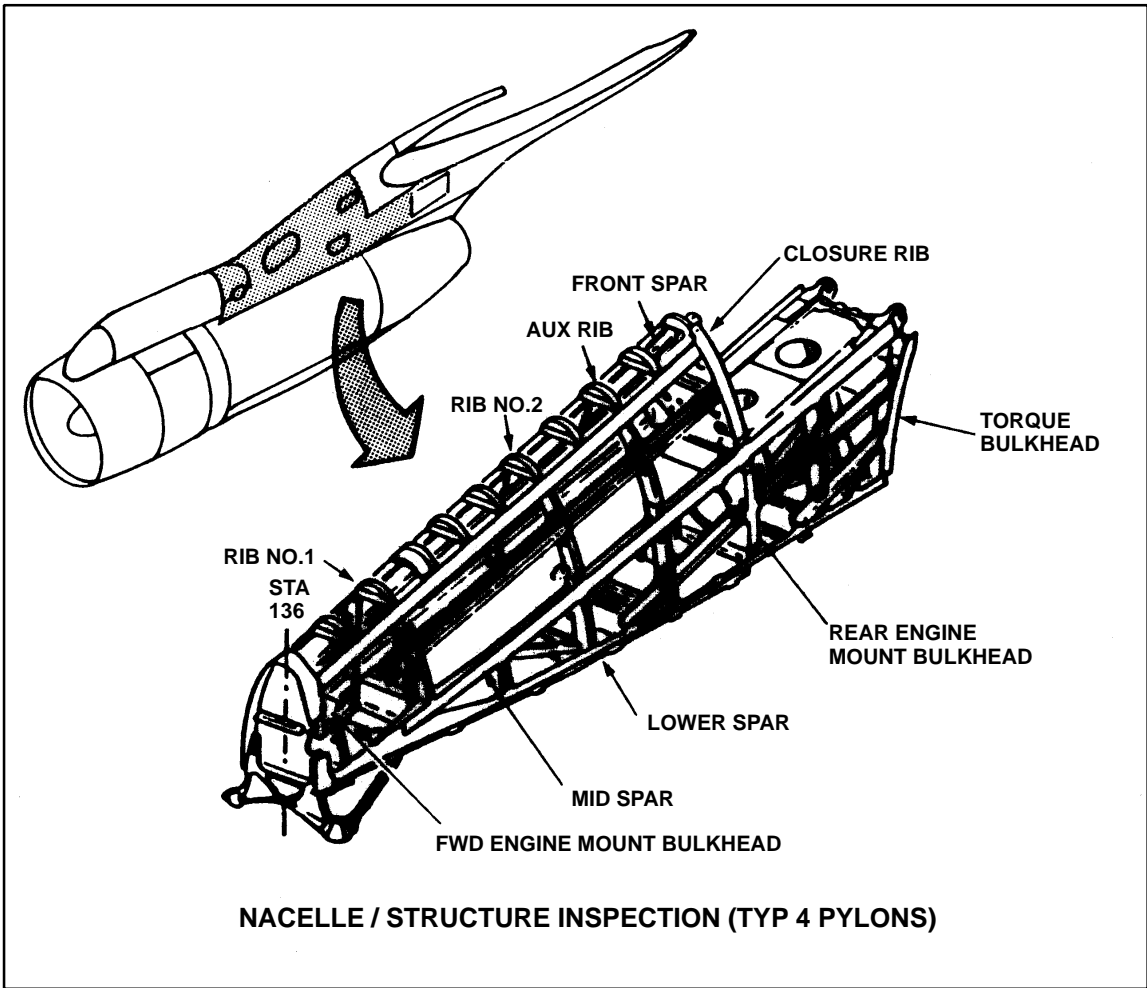

<b>sabena</b> B707	Module: PYLON 3	A/C Reg :	Check :	 <b>U1F3000504</b> Page 3 of 4
	Oper. : RT-MP LC	Issuer : A59513	Cert.St.: 46928	
	Type : STRUCT-INSP	Release Date: 23.11.2005		
Spec. : MECH. INSP				

**NACELLE STRUT # 3 STRUCT EXTERNAL INSP**

					MAINT	RII/INSP	
Nr.	Hardtime	Task	Spec.	Related Documents			
2.	19000 CYC	E3	INS	AD 85-12-01 R1 rev 5439 MMS-328 541370 01001 rev 15.07.05 SSID 54-A40-03/A rev .			
Check: B							
Zones: 457							
Access:							
NRC YES <input type="radio"/> NO <input type="radio"/>		IF YES, NUMBER(S):					

**NACELLE / STRUT # 3 STRUCTURE:**

**CLOSE VISUAL, EXTERNAL:**

Inspect for cracks in nacelle strut skin, paying particular attention to the areas adjacent to the SPARS, BULKHEADS, RIBS & especially near the STRUT & ENG SUPPORT FITTINGS.

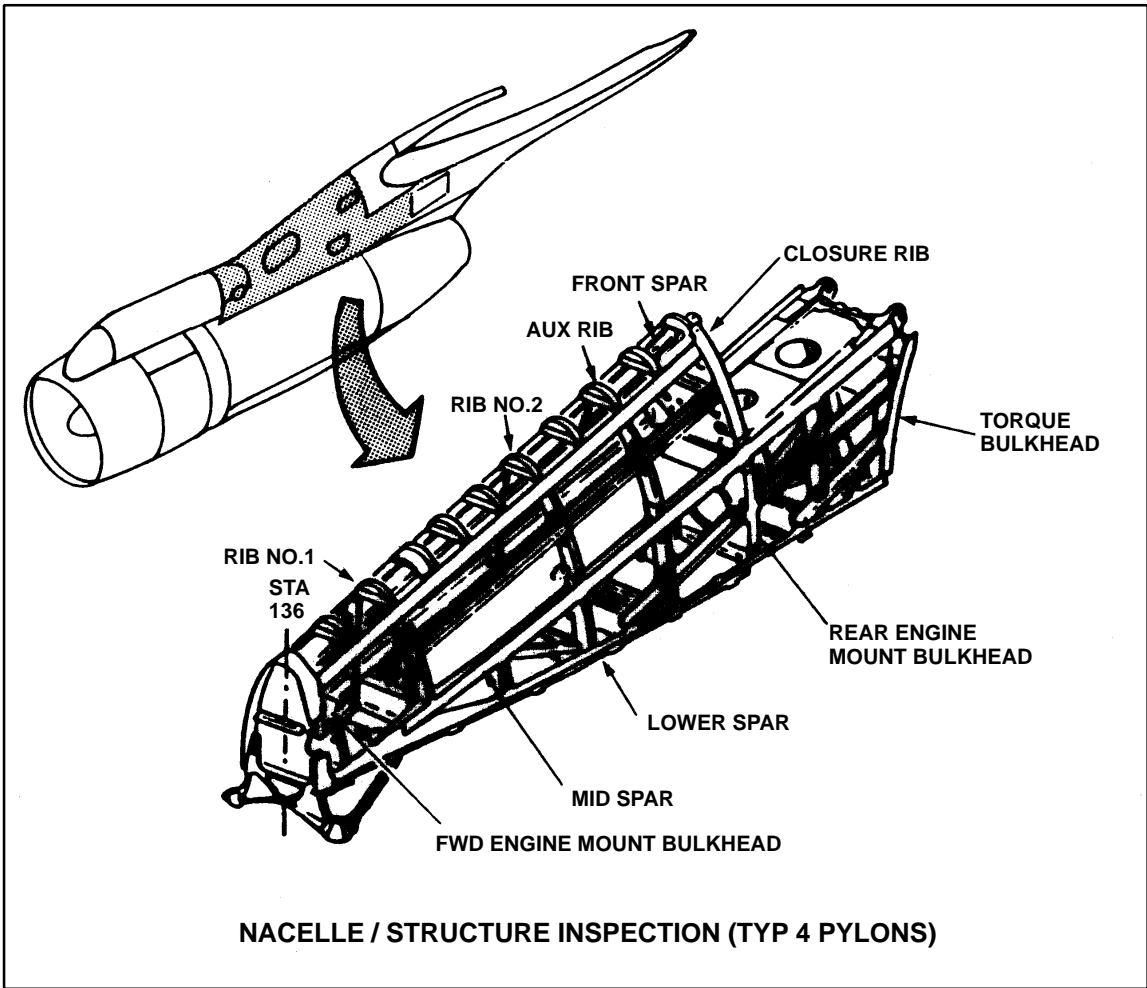

**NACELLE / STRUCTURE INSPECTION (TYP 4 PYLONS)**

<b>sabena</b> <b>B707</b>	Module: PYLON 3	A/C Reg :	Check :	 <b>U1F3000504</b> <b>Page 4 of 4</b>
	Oper. : RT-MP LC	Issuer : A59513	Cert.St.: 46928	
	Type : STRUCT-INSP	Release Date: 23.11.2005		
Spec. : MECH. INSP				

**NACELLE STRUT # 3 STRUCT EXTERNAL INSP**

					MAINT	RII/INSP
Nr.	Hardtime	Task	Spec.	Related Documents		
3.		E3	INS	AD 85-12-01 R1 rev 5439 MMS-328 541370 01001 rev 15.07.05 SSID 54-A40-03/A rev .		
<b>Check:</b> B						
<b>Zones:</b> 457						
<b>Access:</b>						
NRC YES <input type="radio"/> NO <input type="radio"/>		IF YES, NUMBER(S):				

**NACELLE / STRUT # 3 STRUCTURE:**

**CLOSE VISUAL. EXTERNAL:**

Inspect for cracks in nacelle strut skin, paying particular attention to the areas adjacent to the SPARS, BULKHEADS, RIBS & especially near the STRUT & ENG SUPPORT FITTINGS.

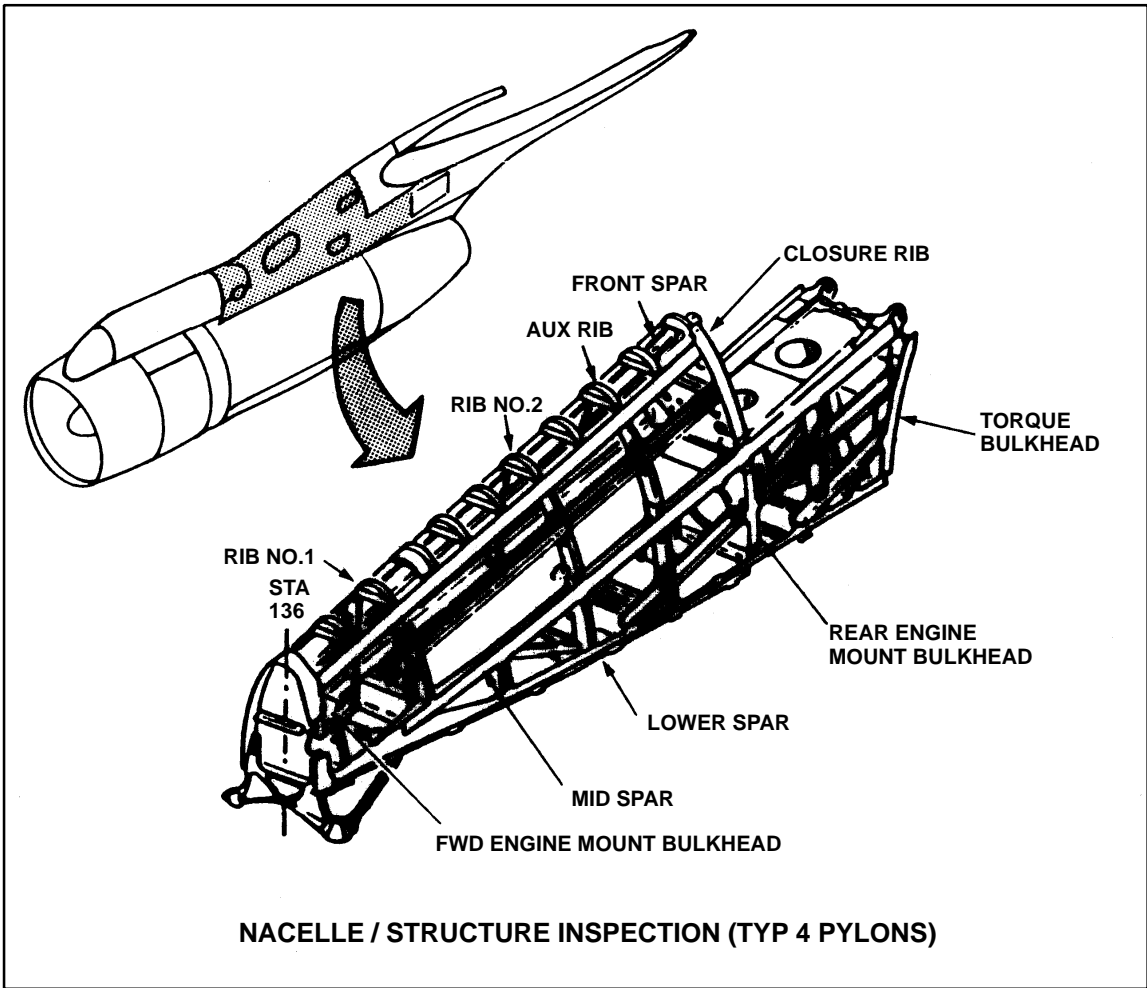

**NACELLE / STRUCTURE INSPECTION (TYP 4 PYLONS)**