



sabena [®] B707	Module: PYLON 4	A/C Reg :	Check :	
	Oper. : RT-MP LC			
	Type : MEC-INSP	Issuer : A43710	Cert.St.: 24828	V1F2000502
	Spec. : MECH. INSP	Release Date: 16.10.2001		Page 1 of 2

ENG #4 ENG MOUNT INSP

Execution / Start Date:	
End Date:	

MAINT	RII/INSP

ENG #4 ENG MOUNT INSP

sabena B707	Module: PYLON 4	A/C Reg :	Check :	 V1F2000502 Page 2 of 2
	Oper. : RT-MP LC	Issuer : A43710	Cert.St.: 24828	
	Type : MEC-INSP	Release Date: 16.10.2001		
	Spec. : MECH. INSP			

ENG #4 ENG MOUNT INSP

					MAINT	RII/INSP
Nr.	Hardtime	Task	Spec.	Related Documents		
1.		E3	INS	MMS-328 544410 11001 rev 15/05/01		
Check: C						
Zones: 458						
Access:						

CONDITION: ENGINE COWLING REMOVED.

ENGINE #4 ATTACH FITTINGS INSPECTION.

Detailed visual inspection of the rear engine support bracket .

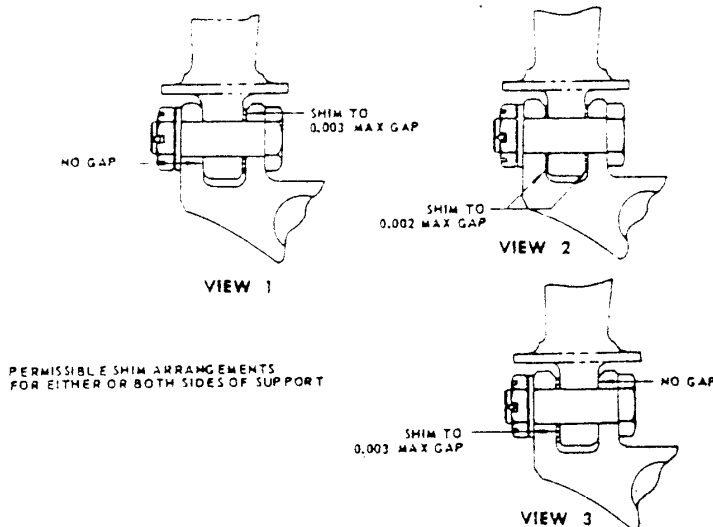
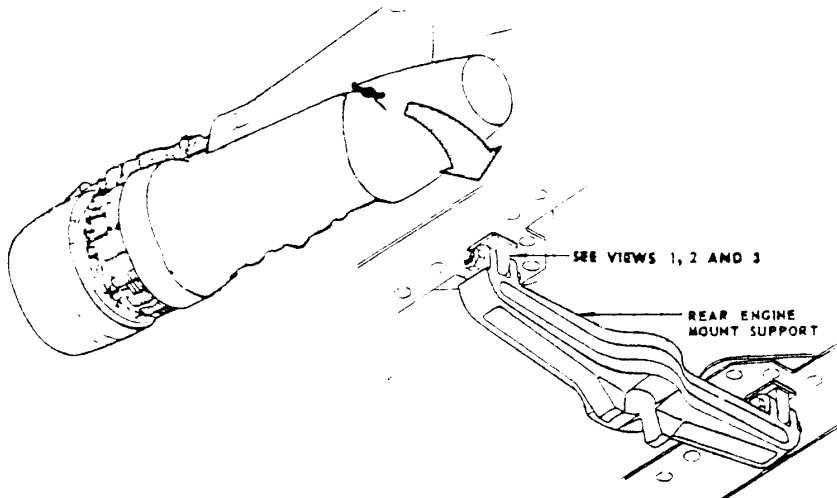

Engine Rear Mount Support