



sabena [®] B707	Module: PYLON 4	A/C Reg :	Check :	 V1F3000505
	Oper. : RT-MP LC			
	Type : STRUCT-INSP	Issuer : A59513	Cert.St.: 46928	
Spec. : MECH. INSP	Release Date: 23.11.2005		Page 1 of 4	

AD 85-12-01 NACELLE STRUT # 4 STRUCT INTERNAL INSP

		MAINT	RII/INSP
Execution / Start Date:			
End Date:			

AD 85-12-01 NACELLE STRUT # 4 STRUCT INTERNAL INSP

sabena B707	Module: PYLON 4	A/C Reg :	Check :	 V1F3000505 Page 2 of 4
	Oper. : RT-MP LC	Issuer : A59513	Cert.St.: 46928	
	Type : STRUCT-INSP	Release Date: 23.11.2005		
Spec. : MECH. INSP				

AD 85-12-01 NACELLE STRUT # 4 STRUCT INTERNAL INSP

					MAINT	RII/INSP
Nr.	Hardtime	Task	Spec.	Related Documents		
1.	19000 CYC	E3	INS	AD 85-12-01 R1 rev 5439 MMS-328 541470 01002 rev 15.07.05 SSID 54-A40-03/B rev .		
Check: B						
Zones: 458						
Access: 1739, 1740, 1741, 1742, 1743, 1747, 3712						
NRC YES <input type="radio"/> NO <input type="radio"/>		IF YES, NUMBER(S):				

NACELLE / STRUT # 4 STRUCTURE:

CLOSE VISUAL. INTERNAL:

Inspect for cracks in NACELLE FRONT, MID & LWR SPAR CHORDS, TORQUE & ENGINE SUPPORT BULKHEADS, NUMBER ONE RIB & CLOSURE RIBS.
Especially near the STRUT & ENG SUPPORT FITTINGS.

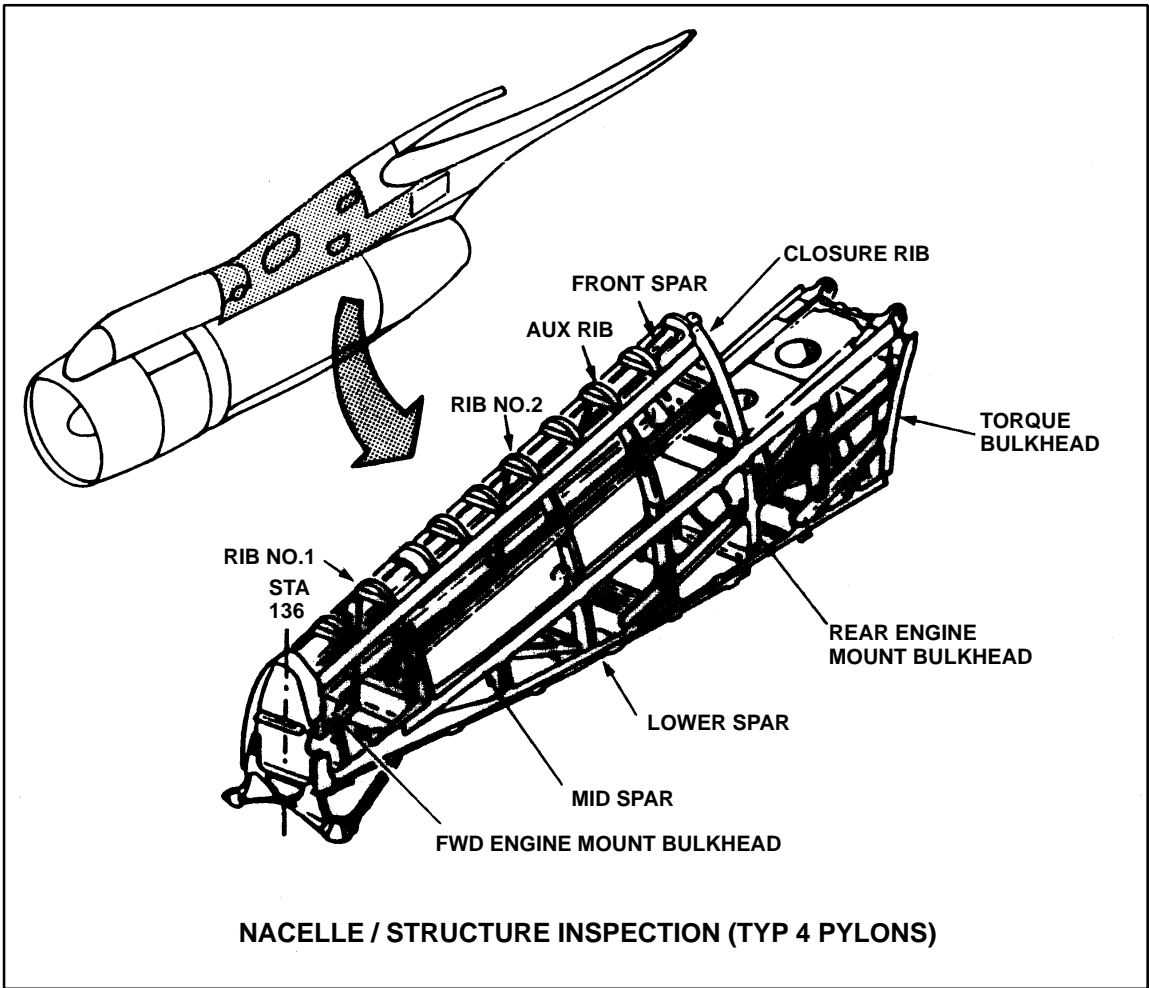

NACELLE / STRUCTURE INSPECTION (TYP 4 PYLONS)

sabena B707	Module: PYLON 4	A/C Reg :	Check :	 V1F3000505 Page 3 of 4
	Oper. : RT-MP LC	Issuer : A59513	Cert.St.: 46928	
	Type : STRUCT-INSP	Release Date: 23.11.2005		
Spec. : MECH. INSP				

AD 85-12-01 NACELLE STRUT # 4 STRUCT INTERNAL INSP

					MAINT	RII/INSP	
Nr.	Hardtime	Task	Spec.	Related Documents			
2.	19000 CYC	E3	INS	AD 85-12-01 R1 rev 5439 MMS-328 541470 01002 rev 15.07.05 SSID 54-A40-03/B rev .			
Check: B							
Zones: 458							
Access: 1739, 1740, 1741, 1742, 1743, 1747, 3712							
NRC YES <input type="radio"/> NO <input type="radio"/>		IF YES, NUMBER(S):					

NACELLE / STRUT # 4 STRUCTURE:

CLOSE VISUAL, INTERNAL:

Inspect for cracks in NACELLE FRONT, MID & LWR SPAR CHORDS, TORQUE & ENGINE SUPPORT BULKHEADS, NUMBER ONE RIB & CLOSURE RIBS.

Especially near the STRUT & ENG SUPPORT FITTINGS.

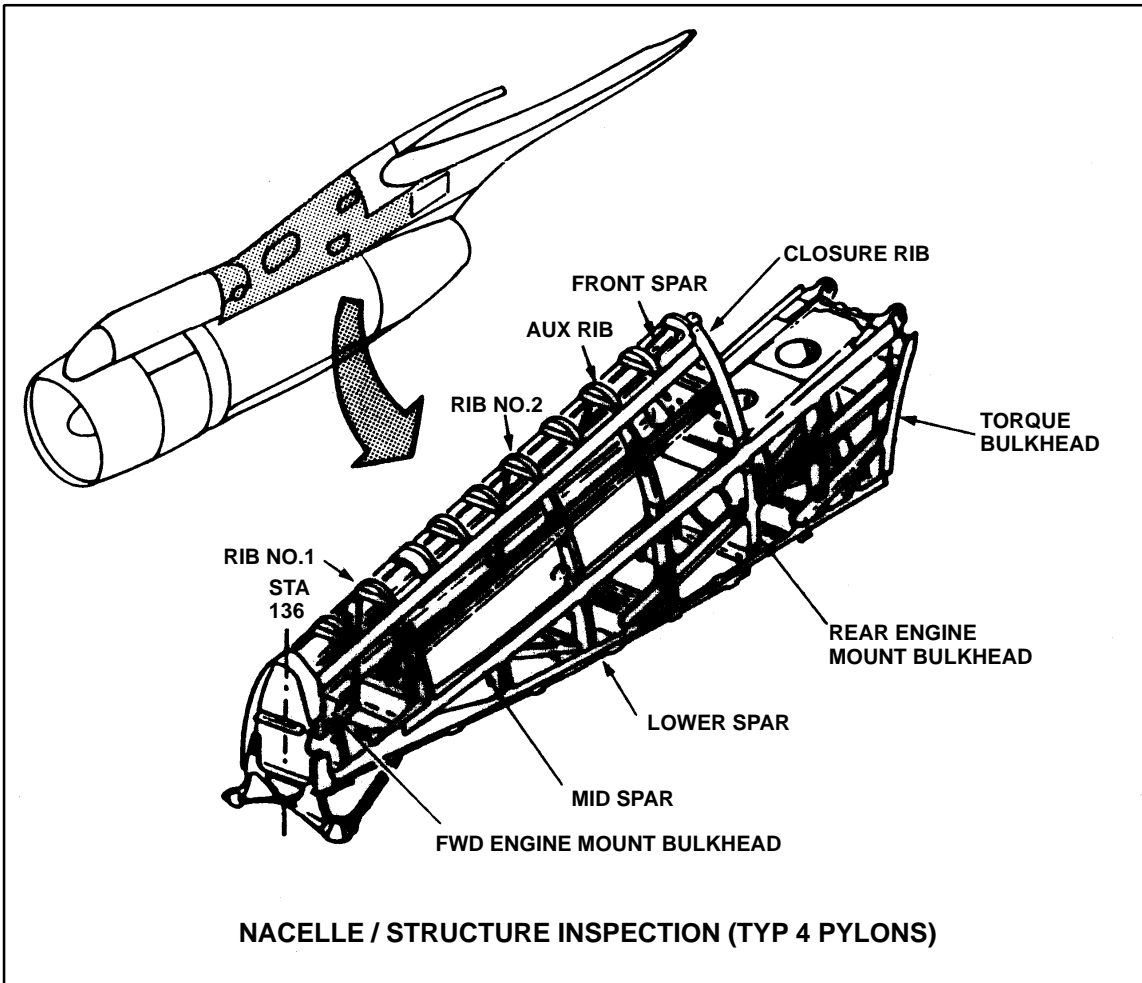

sabena B707	Module: PYLON 4	A/C Reg :	Check :	 V1F3000505 Page 4 of 4
	Oper. : RT-MP LC	Issuer : A59513	Cert.St.: 46928	
	Type : STRUCT-INSP	Release Date: 23.11.2005		
Spec. : MECH. INSP				

AD 85-12-01 NACELLE STRUT # 4 STRUCT INTERNAL INSP

					MAINT	RII/INSP
Nr.	Hardtime	Task	Spec.	Related Documents		
3.		E3	INS	AD 85-12-01 R1 rev 5439 MMS-328 541470 01002 rev 15.07.05 SSID 54-A40-03/B rev .		
Check: B Zones: 458 Access: 1739, 1740, 1741, 1742, 1743, 1747, 3712						
NRC YES <input type="radio"/> NO <input type="radio"/>		IF YES, NUMBER(S):				

NACELLE / STRUT # 4 STRUCTURE:

CLOSE VISUAL, INTERNAL:

Inspect for cracks in NACELLE FRONT, MID & LWR SPAR CHORDS, TORQUE & ENGINE SUPPORT BULKHEADS, NUMBER ONE RIB & CLOSURE RIBS.

Especially near the STRUT & ENG SUPPORT FITTINGS.

