

PILOT'S OPERATING HANDBOOK

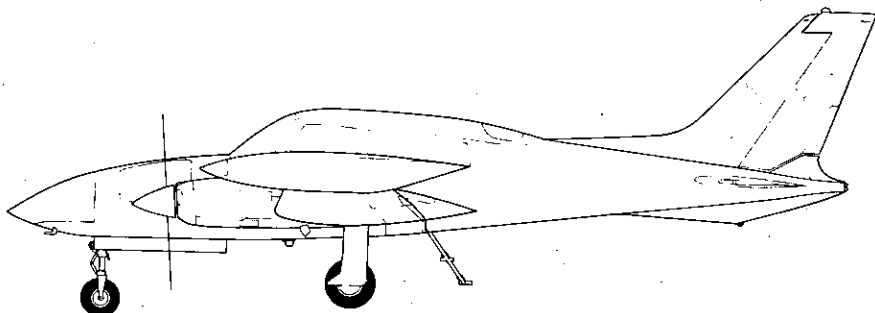

CESSNA AIRCRAFT COMPANY

1976 MODEL 310R

Serial Number 310 R 0412

Registration # **VH-JTV**

IT IS RECOMMENDED THIS
DOCUMENT BE CARRIED IN
THE AIRPLANE AT ALL TIMES

THIS HANDBOOK INCLUDES THE MATERIAL REQUIRED
TO BE FURNISHED TO THE PILOT BY CAR PART 3.

CESSNA AIRCRAFT COMPANY
Wallace Division
Wichita, Kansas

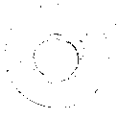

CONGRATULATIONS

Welcome to the ranks of Cessna owners! Your Cessna has been designed and constructed to give you the most in performance, economy, and comfort. It is our desire that you will find flying it, either for business or pleasure, a pleasant and profitable experience.

This Pilot's Operating Handbook has been prepared as a guide to help you get the most pleasure and utility from your airplane. It contains information about your Cessna's equipment, operating procedures, and performance; and suggestions for its servicing and care. We urge you to read it from cover to cover, and to refer to it frequently.

Our interest in your flying pleasure has not ceased with your purchase of a Cessna. Worldwide, the Cessna Dealer Organization backed by Cessna Customer Services Department stands ready to serve you. The following services are offered by most Cessna Dealers:

- THE CESSNA WARRANTY, which provides coverage for parts and labor, is available at Cessna Dealers worldwide. Specific benefits and provisions of warranty, plus other important benefits for you, are contained in your Customer Care Program book supplied with your airplane. Warranty service is available to you at authorized Cessna Dealers throughout the world upon presentation of your Customer Care Card which establishes your eligibility under the warranty.
- FACTORY TRAINED PERSONNEL to provide you with courteous expert service.
- FACTORY APPROVED SERVICE EQUIPMENT to provide you efficient and accurate workmanship.
- A STOCK OF GENUINE CESSNA SERVICE PARTS on hand when you need them.
- THE LATEST AUTHORITATIVE INFORMATION FOR SERVICING CESSNA AIRPLANES, since Cessna Dealers have all of the Service Manuals and Parts Catalogs, kept current by Service Letters and Service News Letters, published by Cessna Aircraft Company.

We urge all Cessna owners to use the Cessna Dealer Organization to the fullest.

A current Cessna Dealer Directory accompanies your new airplane. The Directory is revised frequently, and a current copy can be obtained from your Cessna Dealer. Make your Directory one of your cross-country flight planning aids; a warm welcome awaits you at every Cessna Dealer.

PERFORMANCE AND SPECIFICATIONS

WEIGHT:

Takeoff 5500 Pounds
 Landing 5400 Pounds

SPEED, BEST POWER MIXTURE:

Maximum - Sea Level 207 KTAS
 Maximum Recommended Cruise
 75% Power at 7500 Feet 194 KTAS

RANGE, RECOMMENDED LEAN MIXTURE:

Maximum Recommended Cruise
 75% Power at 7500 Feet 494 Nautical Miles,
 (600 Pounds Usable Fuel) 2.62 Hours and 193 KTAS
 75% Power at 7500 Feet 384 Nautical Miles,
 (978 Pounds Usable Fuel) 4.63 Hours and 193 KTAS
 75% Power at 7500 Feet 1132 Nautical Miles,
 (1218 Pounds Usable Fuel) 5.91 Hours and 194 KTAS

Maximum Range

10,000 Feet (600 Pounds Usable Fuel) 616 Nautical Miles,
 4.12 Hours and 148 KTAS
 10,000 Feet (978 Pounds Usable Fuel) 1152 Nautical Miles,
 7.87 Hours and 145 KTAS
 10,000 Feet (1218 Pounds Usable Fuel) 1511 Nautical Miles,
 10.46 Hours and 144 KTAS

RATE-OF-CLIMB AT SEA LEVEL:

All Engines 1662 Feet Per Minute
 Single-Engine 370 Feet Per Minute

SERVICE CEILING:

All Engines 19,750 Feet
 Single-Engine 7400 Feet

TAKEOFF PERFORMANCE: (82 KIAS, 15° Wing Flaps And 5500 Pounds Weight)

Ground Roll 1335 Feet
 Total Distance Over 50-Foot Obstacle 1700 Feet

LANDING PERFORMANCE: (93 KIAS, 35° Wing Flaps And 5400 Pounds Weight)

Ground Roll 640 Feet
 Total Distance (Over 50-Foot Obstacle) 1790 Feet

STANDARD EMPTY WEIGHTS: (Approximate)

310R 3337 Pounds
 310R II 3578 Pounds

BAGGAGE ALLOWANCE:

. 950 Pounds

WING LOADING:

30.73 Pounds Per Square Foot

POWER LOADING:

9.65 Pounds Per Horsepower

FUEL CAPACITY: (Total)

Standard 102 Gallons
 With Auxiliary Tanks (40 Gallons Usable) 143 Gallons
 With Auxiliary Tanks (63 Gallons Usable) 166 Gallons
 With Auxiliary Tanks (63 Gallons Usable) And Wing Locker Tanks 207 Gallons

OIL CAPACITY: (Total)

. 26 Quarts

ENGINES:

Continental Six-Cylinder, Fuel-Injected Engines IO-520M
 285 Rated Horsepower At 2700 Propeller RPM

PROPELLERS:

Constant Speed, Full Feathering, Three-Bladed 6'4.5" Diameter 0850334-26

NOTE: Range data includes allowances for start, taxi, takeoff, climb, descent and 45-minute reserve at 45% power.



CIVIL AVIATION
SAFETY AUTHORITY
AUSTRALIA

Amendment Record Sheet

Aircraft Registration: VH-~~WME~~ JTV Aircraft Serial Number: 0712

Incorporation Date.	Description of Amendment.	Incorporated By.
02/05/00	Issue of CASA Approval Page and Amendment Sheet for FAA Approved Pilots Operating Handbook D1528-13 at revision 4 dated 02Apr1982 fro the Cessna 310R aircraft.	H. Wheeler.
29/06/00	AD/Cessna 310/57 Admt 1	H. Wheeler.
19/10/01	Apollo GX60 IFR GPS Approval	H. Wheeler.
16/11/01	Engine Failure During Flight D1634-13	H. Wheeler.
03/04/02	Engine Start- Shut down procedures. Vacuum System check supplement.	H. Wheeler.
09.06.09	GARMIN CWX30 GPS APPROVAL ASPEN EFD1000 PRO APPROVAL EDM 760 ENGINE MONITOR APPROVAL AVIDYNE TAS610 APPROVAL	A. WHEELER

COVERAGE

The Pilot's Operating Handbook in the airplane at the time of delivery from Cessna Aircraft Company contains all of the information applicable to the Model 310R and 310R II airplanes, serial number 310R0501 through 310R0800.

REVISIONS

This handbook will be kept current by Service Letters published by Cessna Aircraft Company. These are distributed to Cessna Dealers and to those who subscribe to Cessna Service Letters. If you do not have a subscription you will want to keep in touch with your Cessna Dealer for information concerning the revision status of the handbook. Subsequent revisions should be examined immediately upon receipt and incorporated in the handbook.

REVISED MATERIAL INDICATORS

A bar will extend the full length of deleted, new or revised text and/or illustrations added on new or presently existing pages. This bar will be located adjacent to the applicable text in the margin on the outboard side of the page.

All revised pages will carry the revision number and date below the original page issue date on the applicable page, i.e., Revision 3 - 1 Jan 1978.

Pages affected by the current revision are indicated by an asterisk (*) preceding the pages listed under the page column in the following Log of Effective Pages.

LOG OF EFFECTIVE PAGES

DO NOT USE THIS HANDBOOK FOR OPERATIONAL PURPOSES
UNLESS IT IS MAINTAINED IN A CURRENT STATUS.

Page	Date	Page	Date
*Title	2 Apr 82	2-7	1 Mar 76
i thru ii	1 Nov 75	2-8 thru 2-9	1 Nov 75
*iii thru iv	2 Apr 82	2-10	1 Jan 78
Contents	1 Nov 75	*3-1	2 Apr 82
*1-1	2 Apr 82	3-2 thru 3-4	1 Jan 78
1-2	1 Nov 75	3-4A/3-4B	1 Oct 76
1-3	1 Mar 76	3-5 thru 3-9	1 Nov 75
*1-4	2 Apr 82	*3-10	2 Apr 82
1-5 thru 1-6	1 Nov 75	3-11 thru 3-12	1 Nov 75
1-7 thru 1-8	1 Jan 78	*3-13	2 Apr 82
1-9/1-10	1 Jan 78	3-14 thru 3-15	1 Nov 75
2-1	1 Nov 75	*3-16	2 Apr 82
2-2	1 Jan 78	3-17	1 Jan 78
2-3	1 Mar 76	3-18	1 Oct 76
*2-4	2 Apr 82	3-19 thru 3-28	1 Nov 75
2-5 thru 2-6	1 Nov 75	*3-29 thru 3-30	2 Apr 82

LOG OF EFFECTIVE PAGES (Continued)

Page	Date	Page	Date
4-1	1 Nov 75	*7-22	2 Apr 82
4-2	1 Jan 78	7-23	1 Nov 75
4-3/4-4	1 Jan 78	*7-24 thru 7-26	2 Apr 82
4-5 thru 4-6	1 Nov 75	7-27 thru 7-30	1 Nov 75
4-7 thru 4-9	1 Jan 78	7-31	1 Mar 76
4-10 thru 4-12	1 Nov 75	*7-32	2 Apr 82
*4-13 thru 4-14	2 Apr 82	7-33 thru 7-41	1 Nov 75
4-15 thru 4-16	1 Nov 75	7-42 thru 7-44	1 Jan 78
4-17	1 Jan 78	*8-1	2 Apr 82
4-18	1 Nov 75	8-2 thru 8-7	1 Nov 75
4-19	1 Oct 76	*8-8	2 Apr 82
4-20 thru 4-21	1 Jan 78	8-9	1 Mar 76
*4-22 thru 4-24	2 Apr 82	8-10	1 Nov 75
4-25 thru 4-26	1 Jan 78	*8-11	2 Apr 82
4-27	1 Nov 75	8-12 thru 8-13	1 Nov 75
*4-28	2 Apr 82	*8-14 thru 8-16	2 Apr 82
4-29 thru 4-30	1 Nov 75	9-1	1 Jan 78
4-31/4-32	1 Nov 75	*9-2	2 Apr 82
5-1 thru 5-4	1 Nov 75	*Index-1 thru Index-6	2 Apr 82
5-5	1 Jan 78	*Index-7/Index-8	2 Apr 82
5-5 thru 5-23	1 Nov 75		
5-24 thru 5-25	1 Mar 76		
5-26 thru 5-29	1 Nov 75		
5-30	1 Jan 78		
5-31 thru 5-44	1 Nov 75		
6-1 thru 6-28	1 Nov 75		
6-29/6-30	1 Nov 75		
*7-1	2 Apr 82		
7-2 thru 7-21	1 Nov 75		

NOTE

Refer to Section 9, Table of Contents, for supplements applicable to optional systems.

TABLE OF CONTENTS

SECTION	PAGE
1 GENERAL	1-1
2 LIMITATIONS	2-1
3 EMERGENCY PROCEDURES	3-1
4 NORMAL PROCEDURES	4-1
5 PERFORMANCE	5-1
6 WEIGHT & BALANCE/EQUIPMENT LIST.....	6-1
7 AIRPLANE & SYSTEMS DESCRIPTIONS	7-1
8 AIRPLANE HANDLING, SERVICE & MAINTENANCE	8-1
9 SUPPLEMENTS	9-1
ALPHABETICAL INDEX	Index-1

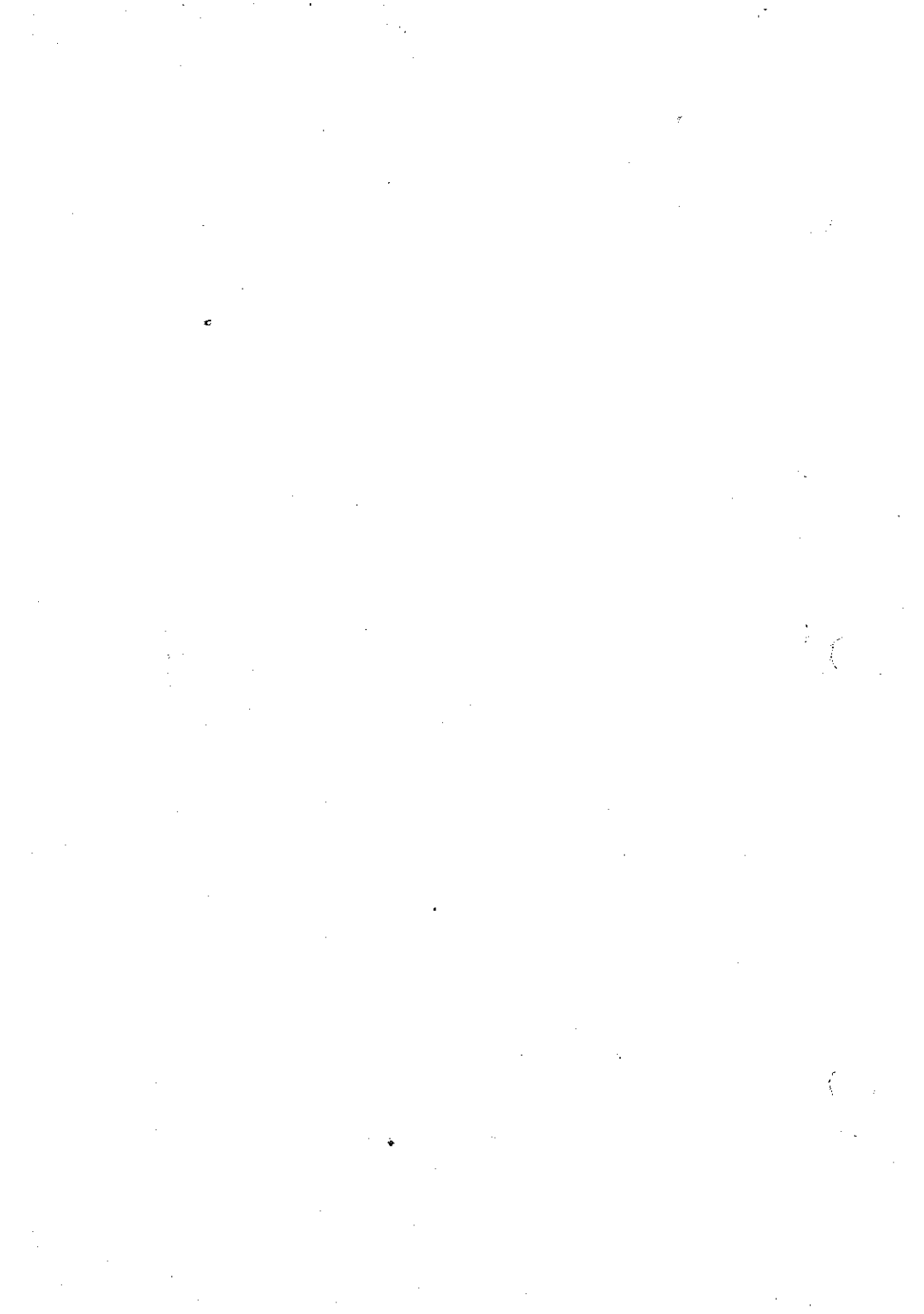

SECTION 1 GENERAL

TABLE OF CONTENTS

	Page		Page
INTRODUCTION	1-1	SYMBOLS, ABBREVIATIONS AND TERMINOLOGY	1-6
ENGINES	1-1	General Airspeed Ter- minology and Symbols	1-6
THREE-VIEW DRAWING	1-2	Meteorological Terminology	1-7
PROPELLERS	1-3	Power Terminology	1-8
FUEL	1-3	Airplane Performance and Flight Planning Terminology	1-8
OIL	1-4	Weight and Balance Terminology	1-8
MAXIMUM CERTIFICATED WEIGHTS	1-4		
CABIN, BAGGAGE AND ENTRY DIMENSIONS	1-5		
STANDARD AIRPLANE WEIGHTS	1-6		
SPECIFIC LOADINGS	1-6		

INTRODUCTION

This handbook consists of 9 sections and an alphabetical index as shown on the Contents page. This handbook includes the material required to be furnished to the pilot by CAR 3. It also contains supplemental data supplied by Cessna Aircraft Company. Specific information can be rapidly found by referring to the Contents page for the appropriate section, then referring to the Table Of Contents on the first page of the appropriate section, or by use of the Alphabetical Index.

Section 1 of the Pilot's Operating Handbook presents basic airplane data and general information which will be of value to the pilot.

ENGINES

Number of Engines: 2

Manufacturer: Teledyne Continental Motors

Engine Model
Number: IO-520-M

Engine Type: Fuel injected, direct drive, air-cooled, horizontally opposed, six cylinder, 520 cubic-inch displacement.

Horsepower: 285 rated horsepower at 2700 propeller RPM.

THREE-VIEW DRAWING

* MAXIMUM HEIGHT OF AIRPLANE WITH NOSE GEAR DEPRESSED IS 10'11.75"

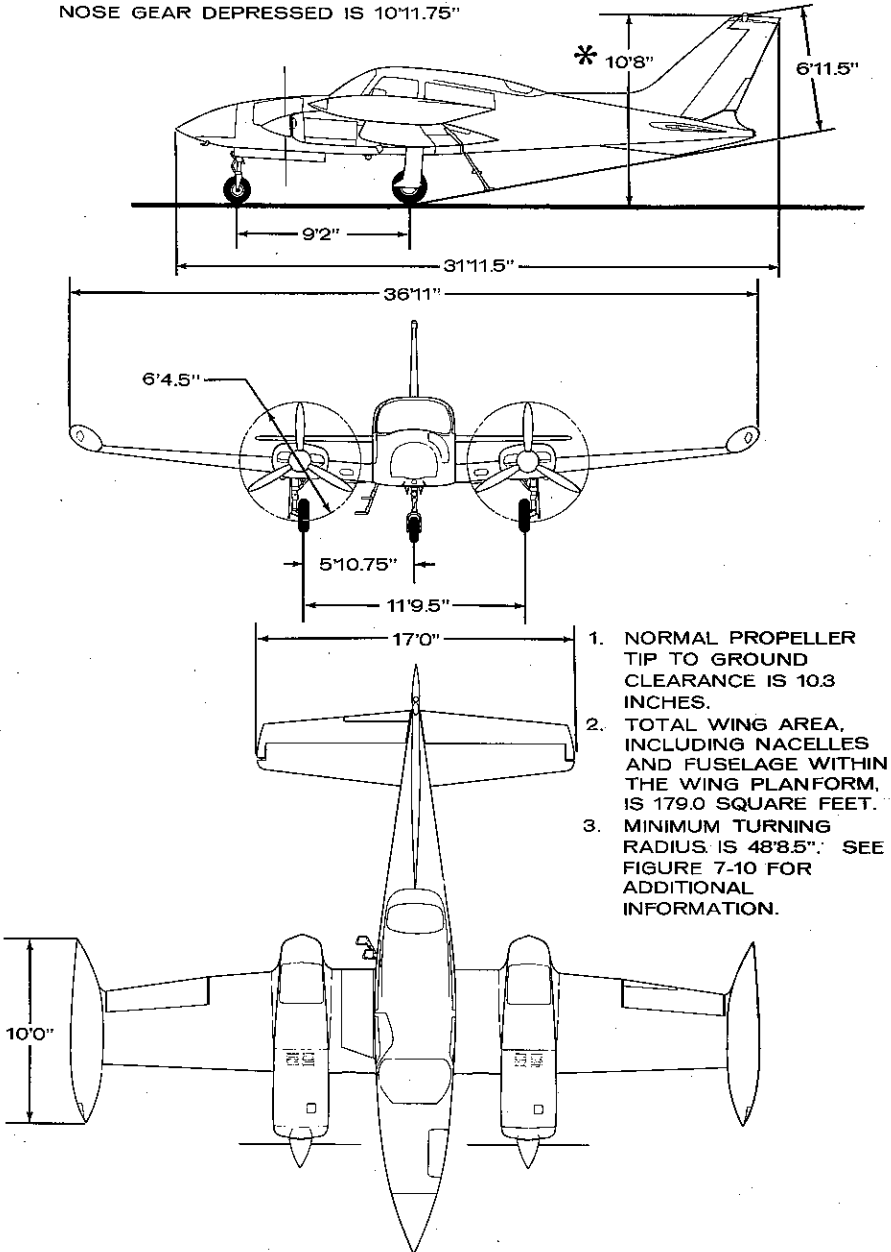

Figure 1-1

PROPELLERS

Number of Propellers: 2

Manufacturer: McCauley Accessory Division, Cessna Aircraft Company

Propeller Part Number: 0850334-26

Number of Blades: 3

Propeller Diameter: 6'4.5"

Propeller Type: Constant speed, full feathering, nonreversible hydraulically actuated

Blade Range: (At 30-Inch Station)
 a. Low Pitch 13.9° +0.2°
 b. Feather 81.7° ±0.3°

FUEL

Grade: Aviation grade 100/130 (Green Color). Low lead aviation grade 100LL (Blue Color) is a suitable alternate. Isopropyl alcohol may be added to the fuel supply in quantities not to exceed 1% of the total. Refer to Section 8 for additional information.

Total and Usable: See Figure 1-2

FUEL TABLE

System	Total Fuel Capacity (U.S. Gallons)	Usable Fuel (U.S. Gallons)
Standard System	102	100
Standard System with Optional Wing Locker Tanks	143	140
Standard System with Optional 40-Gallon Auxiliary Tanks	143	140
Standard System with Optional 63-Gallon Auxiliary Tanks	166	163
Standard System with Optional Wing Locker Tanks and Optional 40-Gallon Auxiliary Tanks	184	180
Standard System with Optional 63-Gallon Auxiliary Tanks and Optional Wing Locker Tanks	207	203

Figure 1-2

OIL

Grade: Aviation grade engine oil. Refer to Section 8 for additional information.

Viscosity:	SAE Rating	Ambient Temperature - °C (°F)
	50	Above 4.4 (40)
	30	Below 4.4 (40)
	Multiviscosity	Unrestricted - After 25 Hours

Total Sump Capacity: 12 quarts per engine.

Drain and Refill Quantity: 13 quarts per engine including one quart for oil filter.

Oil Quantity Operating Range: Do not operate engine on less than 9 quarts. To minimize loss of oil through breather, fill to 10-quart level for normal flights of less than 3 hours. For extended flight, fill to capacity.

NOTE

Dip stick indicates 1 quart lower than actual oil quantity in the engine.

MAXIMUM CERTIFICATED WEIGHTS

Maximum Takeoff Weight: 5500 pounds

Maximum Landing Weight: 5400 pounds

Maximum Zero Fuel Weight: 4900 pounds

- Maximum Weights in Baggage Compartments:
- a. Left and Right Wing Lockers - 120 pounds each. When optional wing locker fuel is installed, the applicable wing locker baggage capacity is reduced to 40 pounds.
 - b. Nose Bay - 350 pounds less installed optional equipment. Refer to the loading placard in the airplane nose baggage bay.
 - c. Aft Cabin (Station 96) See Figure 1-3 - 200 pounds.
 - d. Aft Cabin (Station 124 Standard or Station 126 Optional) See Figure 1-3 - 160 pounds.

CABIN, BAGGAGE AND ENTRY DIMENSIONS

COMPARTMENT VOLUME - CUBIC FEET

NOSE	21.0
WING LOCKER EACH	9.25
AFT CABIN (STATION 96 AND STATION 124)	26.1

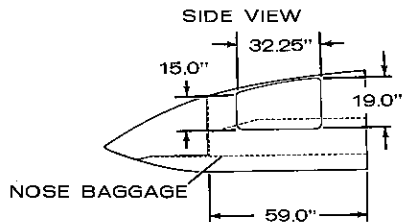
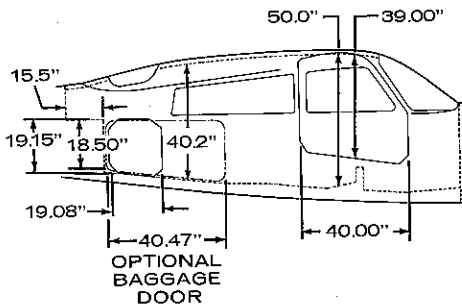
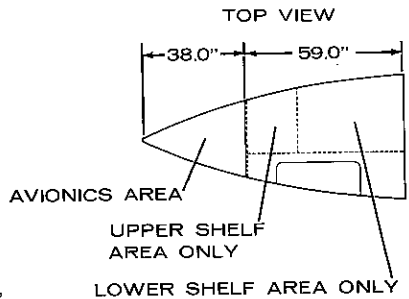
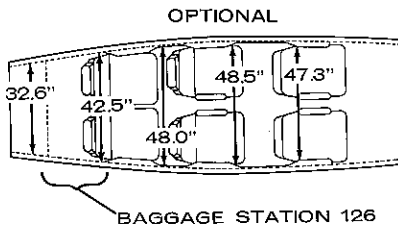
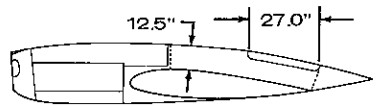
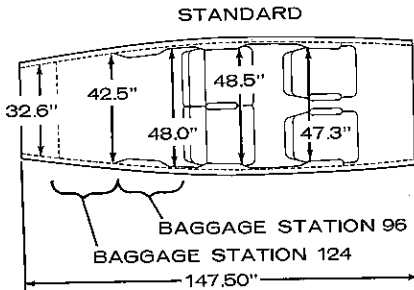
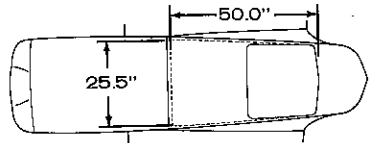

Figure 1-3

STANDARD AIRPLANE WEIGHTS

Standard Empty Weight: 3337 pounds (3578 pounds for 310R II)

Maximum Useful Load: 2163 pounds (1922 pounds for 310R II)

SPECIFIC LOADINGS

Wing Loading: 30.73 pounds per square foot

Power Loading: 9.65 pounds per horsepower

SYMBOLS, ABBREVIATIONS AND TERMINOLOGY

GENERAL AIRSPEED TERMINOLOGY AND SYMBOLS

- CAS Calibrated Airspeed is the indicated speed corrected for position and instrument error. Calibrated airspeed is equal to true airspeed in standard atmosphere at sea level.
- G G is acceleration due to gravity.
- IAS Indicated Airspeed is the speed as shown on the airspeed indicator when corrected for instrument error. IAS values published in this Handbook assume zero instrument error.
- KCAS Calibrated Airspeed expressed in knots.
- KIAS Indicated Airspeed expressed in knots.
- KTAS True Airspeed expressed in knots.
- TAS True Airspeed is the airspeed relative to undisturbed air which is the CAS corrected for altitude, temperature and compressibility.
- V_A Maneuvering Speed is the maximum speed at which application of full available aerodynamic control will not overstress the airplane.
- V_{FE} Maximum Flap Extended Speed is the highest speed permissible with wing flaps in a prescribed extended position.
- V_{LE} Maximum Landing Gear Extended Speed is the maximum speed at which an airplane can be safely flown with the landing gear extended.
- V_{LO} Maximum Landing Gear Operating Speed is the maximum speed at which the landing gear can be safely extended or retracted.

V_{MC_A}	<u>Air Minimum Control Speed</u> is the minimum flight speed at which the airplane is controllable with a bank of not more than 5° when one engine suddenly becomes inoperative and the remaining engine is operating at takeoff power.
V_{NE}	<u>Never Exceed Speed</u> is the speed limit that may not be exceeded at any time.
V_{NO}	<u>Maximum Structural Cruising Speed</u> is the speed that should not be exceeded except in smooth air and then only with caution.
V_X	<u>Best Angle-of-Climb Speed</u> is the airspeed which delivers the greatest gain of altitude in the shortest possible horizontal distance.
V_Y	<u>Best Rate-of-Climb Speed</u> is the airspeed which delivers the greatest gain in altitude in the shortest possible time.

METEOROLOGICAL TERMINOLOGY

$^{\circ}C$	Temperature in degrees Celsius.
$^{\circ}F$	Temperature in degrees Fahrenheit.
ISA	International Standard Atmosphere in which: (1) The air is a dry perfect gas; (2) The temperature at sea level is 15° Celsius (59° Fahrenheit); (3) The pressure at sea level is 29.92 inches Hg. (1013.2 mb); (4) The temperature gradient from sea level to the altitude at which the temperature is -56.5°C (-69.7°F) is -1.98°C (-3.5°F) per 1000 feet.
OAT	<u>Outside Air Temperature</u> is the free air static temperature, obtained either from inflight temperature indications adjusted for instrument error and compressibility effects or ground meteorological sources.
Pressure Altitude	Altitude measured from standard sea-level pressure (29.92 inches Hg.) by a pressure or barometric altimeter. It is the indicated pressure altitude corrected for position and instrument error. In this handbook, altimeter instrument errors are assumed to be zero.
Wind	The wind velocities recorded as variables on the charts of this handbook are to be understood as the headwind or tailwind components of the reported winds.

POWER TERMINOLOGY

BHP	Brake horsepower means the power delivered at the propeller shaft of an airplane engine.
Critical Altitude	The maximum altitude at which in standard temperature it is possible to maintain a specified power.
Maximum Continuous Power	The power developed in a standard atmosphere from sea level to the critical altitude at the maximum RPM and manifold pressure approved for use during periods of unrestricted duration.
RPM	The revolutions per minute (RPM) of an engine refers to the rotational speed of the propeller shaft, as shown on a tachometer.

AIRPLANE PERFORMANCE AND FLIGHT PLANNING TERMINOLOGY

Accelerate-Go Distance	The distance required to accelerate an airplane to a specified speed and, assuming failure of an engine at the instant that speed is attained, continue takeoff on the remaining engine to a height of 50 feet.
Accelerate-Stop Distance	The distance required to accelerate an airplane to a specified speed and, assuming failure of an engine at the instant that speed is attained, to bring the airplane to a stop.
Acrobatic Maneuver	An intentional maneuver involving an abrupt change of an airplane's attitude, an abnormal attitude, or abnormal acceleration, not necessary for normal flight.
Balked Landing	A balked landing is an aborted landing (i.e., all engines go-around).
Balked Landing Transition Speed	The minimum speed at which transition to a balked landing climb should be attempted.
Demonstrated Crosswind Velocity	The demonstrated crosswind velocity is the velocity of the crosswind component for which adequate control of the airplane during takeoff and landing was actually demonstrated during certification tests. The value shown is not considered to be limiting. This value is not an aerodynamic limit for the airplane.

WEIGHT AND BALANCE TERMINOLOGY

Arm	The horizontal distance from the reference datum to the center of gravity (C.G.) of an item.
Basic Empty Weight	Standard empty weight plus installed optional equipment.
C.G. Arm	The arm obtained by adding the airplane's individual moments and dividing the sum by the total weight.

C.G. Limits	The extreme center of gravity locations within which the airplane must be operated at a given weight.
Center of Gravity (C.G.)	The point at which an airplane would balance if suspended. Its distance from the reference datum is found by dividing the total moment by the total weight of the airplane.
Jack Point	One of the three points on the airplane designed to rest on a jack.
MAC	The mean aerodynamic chord of a wing is the chord of an imaginary airfoil which throughout the flight range will have the same force vectors as those of the wing.
Maximum Landing Weight	Maximum weight approved for the landing touchdown.
Maximum Takeoff Weight	Maximum weight approved for the start of the takeoff run.
Maximum Zero Fuel Weight	Maximum weight exclusive of usable fuel.
Moment	The product of the weight of an item multiplied by its arm. (Moment divided by a constant is used to simplify balance calculations by reducing the number of digits.)
Payload	Weight of occupants, cargo and baggage.
Reference Datum	An imaginary vertical plane from which all horizontal distances are measured for balance purposes.
Residual Fuel	The undrainable fuel remaining when the airplane is defueled in a specific attitude by the normal means and procedures specified for draining the tanks.
Standard Empty Weight	Weight of a standard airplane including unusable fuel, full operating fluids and full oil.
Station	A location along the airplane fuselage usually given in terms of distance from the reference datum.
Tare	Tare is the weight of chocks, blocks, stands, etc. used when weighing an airplane, and is included in the scale readings. Tare is deducted from the scale reading to obtain the actual (net) airplane weight.
Unusable Fuel	Fuel remaining after a fuel runout test has been completed in accordance with governmental regulations.
Usable Fuel	Fuel available for flight planning.

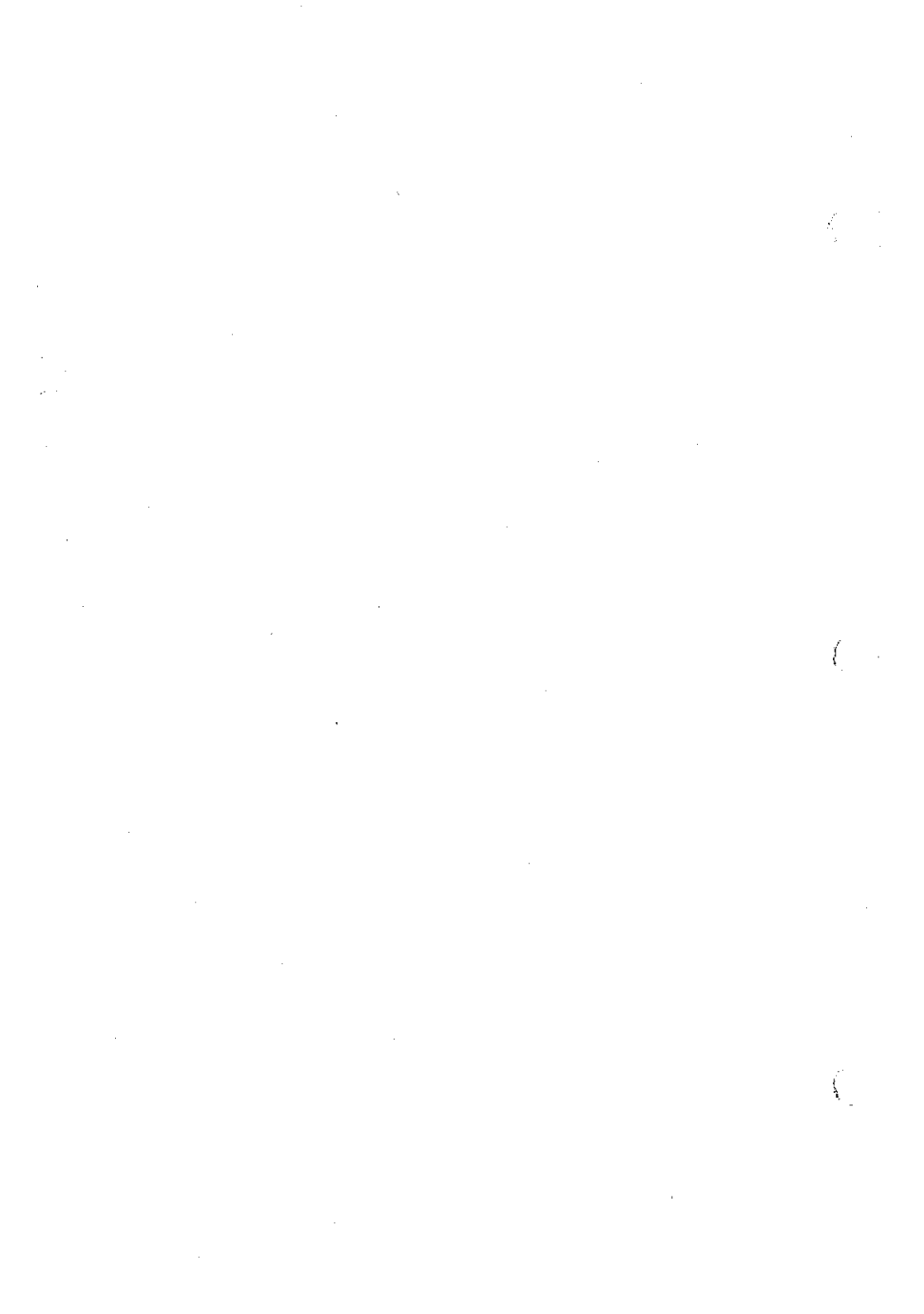

**SECTION 2
LIMITATIONS
TABLE OF CONTENTS**

	Page		Page
INTRODUCTION	2-1	FLIGHT LOAD FACTOR LIMITS . . .	2-6
AIRSPPEED LIMITATIONS	2-2	FLIGHT CREW LIMITS	2-6
ENGINE LIMITATIONS	2-3	OPERATION LIMITS	2-6
WEIGHT LIMITS	2-5	FUEL LIMITATIONS	2-7
MANEUVER LIMITS	2-6	PLACARDS	2-7

INTRODUCTION

Section 2 of the Pilot's Operating Handbook presents the operating limitations, the significance of such limitations, instrument markings, color coding and basic placards necessary for the safe operation of the airplane, its powerplants, standard systems and standard equipment.

NOTE

Refer to Section 9 of this Pilot's Operating Handbook for amended operating limitations, operating procedures, performance data and other necessary information for airplanes equipped with specific options.

AIRSPEED LIMITATIONS (See Figure 2-1)

AIRSPEED LIMITATIONS TABLE

SPEED	IAS	CAS	REMARKS
Maneuvering Speed V_A (Knots)	148	150	Do not make abrupt control movements above this speed.
Maximum Flap Extended Speed V_{FE} (Knots) 15 ⁰ 35 ⁰	158 139	160 140	Do not exceed this speed with the given flap setting.
Maximum Gear Operating Speed V_{LO} (Knots)	138	140	Do not extend landing gear above this speed.
Maximum Gear Extended Speed V_{LE} (Knots)	138	140	Do not exceed this speed with landing gear extended.
Air Minimum Control Speed - V_{MCA} (Knots)	80	81	This is the minimum flight speed at which the airplane is controllable with a bank of not more than 5 ⁰ with one engine inoperative and the remaining engine operating at take-off power.
Best Single-Engine Rate-of-Climb Speed V_y (Knots)	106	107	This speed delivers the greatest gain in altitude in the shortest possible time with one engine inoperative at sea level, standard day conditions and 5500 pounds weight.
Never Exceed Speed V_{NE} (Knots)	223	227	Do not exceed this speed in any operation.
Maximum Structural Cruising Speed V_{NO} (Knots)	181	183	Do not exceed this speed except in smooth air and then only with caution.

Figure 2-1

Airspeed Indicator Markings: See Figure 2-2

AIRSPEED INDICATOR TABLE

MARKING	KIAS VALUE OR RANGE	SIGNIFICANCE
Red Radial	80	Air minimum control speed.
White Arc	72 to 139	Operating speed range with 35° wing flaps. Lower limit is maximum weight stalling speed in landing configuration. Upper limit is maximum speed permissible with flaps extended.
Green Arc	79 to 181	Normal operating range. Lower limit is maximum weight stalling speed with flaps and landing gear retracted. Upper limit is maximum structural cruising speed.
Blue Radial	106	Best single-engine rate-of-climb speed at sea level standard day conditions and 5500 pounds weight.
Yellow Arc	181 to 223	Caution range. Operations must be conducted with caution and only in smooth air.
Red Radial	223	Maximum speed for all operations.

Figure 2-2

ENGINE LIMITATIONS

Number of Engines: 2

Engine Manufacturer: Teledyne Continental Motors

Engine Model Number: IO-520-M

Engine Operating Limits for Takeoff and Continuous Operation:

a. Maximum power for all operations (All Altitudes)

Engine RPM	Manifold Pressure	Time	Max. Head Temp. (°F)	Max. Oil Temp. (°F)
2700	Full Throttle	Continuous	460	240

Oil Viscosity:

SAE Rating	Ambient Temperature - °C (°F)
50	Above 4.4 (40)
30	Below 4.4 (40)
Multiviscosity	Unrestricted - After 25 Hours

Propellers:

- a. Number of Propellers: 2
- b. Manufacturer: McCauley Accessory Division, Cessna Aircraft Company
- c. Part Number: 0850334-26
- d. Number of Blades: 3
- e. Diameter: 6'4.5"
- f. Blade Range: (At 30-Inch Station)
 - (1) Low Pitch 13.9° ±0.2°
 - (2) Feather 81.7° ±0.3°
- g. Operating Limits: 2700 RPM maximum speed

Powerplant Instrument Markings:

- a. Tachometer:
 - (1) Normal Operating 2100 to 2500 RPM (Green Arc)
 - (2) Maximum 2700 RPM (Red Radial)
- b. Manifold Pressure:
 - (1) Normal Operating 15.0 to 24.5 Inches Hg. Manifold Pressure (Green Arc)
- c. Oil Temperature:
 - (1) Normal Operating 75 to 240°F (Green Arc)
 - (2) Maximum 240°F (Red Radial)
- d. Oil Pressure:
 - (1) Minimum Operating 10 PSI (Red Radial)
 - (2) Normal Operating 30 to 60 PSI (Green Arc)
 - (3) Maximum 100 PSI (Red Radial)

e. Cylinder Head Temperature:

- (1) Normal Operating 200 to 460°F (Green Arc)
- (2) Maximum 460°F (Red Radial)

f. Fuel Flow:

- (1) Minimum Operating 2.5 PSI (Red Radial)
- (2) Normal Operating 0.0 Pounds per hour (3.4 PSI) to 155.0 Pounds per hour (21.7 PSI) (Green Arc)
 - (a) Green Radials 45% Power - 59.0 Pounds per hour (6.5 PSI)
55% Power - 71.0 Pounds per hour (7.6 PSI)
65% Power - 82.0 Pounds per hour (8.8 PSI)
75% Power - 94.0 Pounds per hour (10.25 PSI)
 - (b) Blue Triangle 75% Climb Setting - 107.0 Pounds per hour (12.0 PSI)
 - (c) White Arc - Sea Level Takeoff and Climb Power Setting 146.5 Pounds per hour (19.7 PSI) to 150.0 Pounds per hour (20.5 PSI)
 - (d) Blue Radials Altitude Takeoff Power and Climb Power Setting
2000 Feet - 134.0 Pounds per hour (17.0 PSI)
4000 Feet - 124.0 Pounds per hour (15.0 PSI)
6000 Feet - 116.0 Pounds per hour (13.5 PSI)
- (3) Maximum Operating 155.0 Pounds per hour (21.7 PSI) (Red Radial)

WEIGHT LIMITS

Maximum Takeoff Weight: 5500 Pounds

Maximum Landing Weight: 5400 Pounds

Maximum Zero Fuel Weight: 4900 Pounds

Maximum Weights in Baggage Compartments:

a. Left and Right Wing Lockers - 120 pounds each.

- (1) If optional wing locker tanks are installed, change item "a" to 40 pounds each.

b. Nose Bay - 350 pounds less installed optional equipment.

c. Aft Cabin (Station 89 to Station 109) - 200 pounds.

d. Aft Cabin (Station 109 to Station 132) - 160 pounds.

Center of Gravity Limits (Gear Extended):

- a. Aft Limit: 43.6 inches aft of reference datum (34.71% MAC) at 5100 pounds or less and 43.1 inches aft of reference datum (33.90% MAC) at 5500 pounds with straight line variation between these points.
- b. Forward Limit: 38.67 inches aft of reference datum (26.69% MAC) at 5500 pounds and 32.0 inches aft of reference datum (15.84% MAC) at 4500 pounds or less with straight line variation between these points.
- c. See Weight and Balance Data in Section 6 for loading schedule. The reference datum is at the forward face of the fuselage bulkhead forward of the rudder pedals. The mean aerodynamic chord (MAC) is 61.48 inches in length. The leading edge of the MAC is 22.26 inches aft of the reference datum.

MANEUVER LIMITS

This is a normal category airplane. Acrobatic maneuvers, including spins, are prohibited.

FLIGHT LOAD FACTOR LIMITS

The design load factors are 150% of the following and in all cases, the structure exceeds design loads.

At Design Takeoff Weight of 5500 Pounds:

- a. Landing gear up, wing flaps 0° +3.8G to -1.52G
- b. Landing gear down, wing flaps 35° +2.0G

FLIGHT CREW LIMITS

Minimum Flight Crew for FAR 91 operations is one pilot.

OPERATION LIMITS

The standard airplane is approved for day and night operation under VFR conditions. With the proper optional equipment installed, the airplane is approved for day and night IFR conditions.

FUEL LIMITATIONS See Figure 2-3

Fuel Pressure:

- a. Minimum: 2.5 PSI
- b. Maximum: 21.7 PSI (155.0 Pounds Per Hour)

Fuel Grade:

- a. Aviation Grade 100/130 (Green Color).
Low Lead Aviation Grade 100LL (Blue Color) is a suitable alternate.

FUEL TABLE

System	Total Fuel Capacity (U.S. Gallons)	Usable Fuel (U.S. Gallons)
Standard System	102	100
Standard System with Optional Wing Locker Tanks	143	140
Standard System with Optional 40-Gallon Auxiliary Tanks	143	140
Standard System with Optional 63-Gallon Auxiliary Tanks	166	163
Standard System with Optional Wing Locker Tanks and Optional 40-Gallon Auxiliary Tanks	184	180
Standard System with Optional 63-Gallon Auxiliary Tanks and Optional Wing Locker Tanks	207	203

Figure 2-3

PLACARDS

Emergency Exit:

- a. On pilot's side window:
"EMERGENCY EXIT - PULL HANDLE - PUSH BOTTOM OF WINDOW OUT WITH SUSTAINED FORCE."
- b. Below aft lower corner of pilot's side window:
"EMERGENCY WINDOW RELEASE - PULL."

Adjacent to Left Engine Fuel Selector:

- a. "50 GAL - LEFT MAIN" - (Green Sector)
- b. "50 GAL. - RIGHT MAIN" - (Yellow Sector)
- c. "LEFT ENGINE - OFF" - (Red Sector)
- d. If optional 40-gallon auxiliary tank system is installed, "20 GAL. - LEFT AUX." - (Yellow and Green Sector)
- e. If optional 63-gallon auxiliary tank system is installed, change item "d" to "31.5 GAL. - LEFT AUX." - (Yellow and Green Sector)

Adjacent to Right Engine Fuel Selector:

- a. "50 GAL. - RIGHT MAIN" - (Green Sector)
- b. "50 GAL. - LEFT MAIN" - (Yellow Sector)
- c. "RIGHT ENGINE - OFF" - (Red Sector)
- d. If optional 40-gallon auxiliary tank system is installed, "20 GAL. - RIGHT AUX." - (Yellow and Green Sector)
- e. If optional 63-gallon auxiliary tank system is installed, change item "d" to "31.5 GAL. - RIGHT AUX." - (Yellow and Green Sector)

On Floor Between Fuel Selectors:

- a. "SET FUEL SELECTOR VALVE TO LEFT MAIN TANK FOR LEFT ENGINE AND RIGHT MAIN TANK FOR RIGHT ENGINE IN TAKEOFF, LANDING, AND EMERGENCY."
- b. "TAKEOFF AND LAND WITH AUXILIARY FUEL PUMPS ON."
- c. "USE FULL RICH MIXTURE AND AUXILIARY FUEL PUMPS ON 'LOW' WHEN SWITCHING FUEL TANKS. (FEEL FOR DETENT)."
- d. If optional wing locker fuel tanks are installed:
"OPERATE ON MAIN TANKS UNTIL FUEL QUANTITY IS LESS THAN 180 LBS/TANK."
"TRANSFER WING LOCKER FUEL TO MAIN TANKS IN STRAIGHT AND LEVEL FLIGHT ONLY."
"TURN TRANSFER PUMPS OFF WHEN LIGHTS ILLUMINATE."
"OPERATE ON AUXILIARY TANKS ONLY WHEN MAIN TANK IS AGAIN LESS THAN 180 LBS/TANK."
- e. "TO EXTEND GEAR MANUALLY, PULL OUT CRANK TO ENGAGE AND TURN CLOCKWISE. CAUTION: 1. GEAR SWITCH SHOULD BE IN NEUTRAL BEFORE OPERATING MANUAL SYSTEM. 2. PUSH BUTTON AND STOW CRANK BEFORE OPERATING ELECTRICALLY."
- f. "USE MAIN TANKS FOR TAKEOFF, LANDING, AND FIRST 60 MINUTES FLIGHT."
- g. If optional 63-gallon auxiliary tank system is installed, change item "f" to "USE MAIN TANKS FOR TAKEOFF, LANDING, AND FIRST 90 MIN FLIGHT."

On Wire Tunnel Trim Above Circuit Breaker Panel:

- a. "OPERATIONAL LIMITS"
 - "A. THIS AIRPLANE MUST BE OPERATED AS A NORMAL CATEGORY AIRPLANE IN COMPLIANCE WITH THE OPERATING LIMITATIONS STATED IN THE FORM OF PLACARDS, MARKINGS, AND HANDBOOKS (PILOT'S CHECKLIST)."
 - "B. NO ACROBATIC MANEUVERS INCLUDING SPINS APPROVED."
 - "C. AIR MINIMUM CONTROL SPEED: 80 KIAS."
 - "D. MAXIMUM GEAR OPERATING SPEED: 138 KIAS."
 - "E. MAXIMUM GEAR EXTENDED SPEED: 138 KIAS."
 - "F. MAXIMUM FLAP EXTENDED SPEED (15° FLAP): 158 KIAS"
(35° FLAP): 139 KIAS"
 - "G. MAXIMUM MANEUVERING SPEED: 148 KIAS."

b. "IDLE POWER STALL SPEEDS (KIAS)."

CONFIGURATION	ANGLE OF BANK			
	0°	20°	40°	60°
GEAR UP - FLAPS UP	79	82	91	112
GEAR DOWN - FLAPS DOWN 15°	77	79	88	109
GEAR DOWN - FLAPS DOWN 35°	72	74	82	101

On Instrument Panel:

- a. "OPEN DEFROST OR CABIN AIR DURING HEATER OPERATION."
- b. "HEATER OVERHEAT" - "PUSH" - "TEST T AND B" - "LOW VOLT."
- c. Near the fuel tank quantity indicator selector switch:
"MAIN - AUX." - "L.H. AUX." - "R.H. AUX."

On Rudder Horn:

- a. If optional rudder mounted rotating beacon is installed:
"ANTI-COLLISION LIGHT REQ'D FOR PROPER RUDDER MASS BALANCE. DO NOT REMOVE."

On Wing Locker Doors:

- a. "MAX. BAGGAGE - 120 POUNDS."
- b. If optional wing locker tanks are installed, change item "a" to:
"MAX BAGGAGE - 40 LBS."





On Baggage Door:

- a. "MAXIMUM BAGGAGE CAPACITY - STATION 89 TO STATION 109 - 200 POUNDS, STATION 109 TO STATION 132 - 160 POUNDS. SEE WEIGHT AND BALANCE DATA FOR DETAILED LOADING INSTRUCTIONS."

In Nose Baggage Area:

- a. "MAXIMUM BAGGAGE XX.X
MAX. CAPACITY 350 LBS. LESS
XX.X OPTIONAL EQUIP."

On Engine Control Pedestal:

- a. "T.O. - T.O." (Takeoff) range on elevator trim tab indicator (Nose up 4° to nose up 11°) "NOSE DN" "NOSE UP"
- b. Above rudder trim tab: "L NOSE R"
- c. Above aileron trim tab: "L ROLL R"
- d. "ENGINE ALTERNATE AIR - PULL OUT -  LOCK R" - " LOCK L"
- e. If propeller unfeathering accumulators are installed - "PROPELLER UNFEATHERING ACCUMULATORS ARE INSTALLED ON THIS AIRPLANE."
- f. "COWL FLAPS - PULL TO CLOSE" - " LOCK" - " LOCK"

On Engine Control Quadrant If Optional Propeller Synchrophaser Is Installed:

- a. "PROP SYNCHROPHASER"
- b. "PHASE-SYNC-OFF"
- c. "PHASING"
- d. "MUST BE OFF FOR TAKEOFF, LANDING, AND SINGLE ENGINE OPERATION"

Adjacent to Wing Flap Position Switch:

- a. BLUE SEGMENT - 158 KIAS 0° to 15°.
- b. WHITE SEGMENT - 138 KIAS 15° to 35°.

Adjacent to Fuel Strainer Drain:

- a. "FUEL STRAINER - DRAIN DAILY - NOTE: IF WATER IS OBSERVED AT THE FUEL STRAINER, FUEL TANK SUMPS AND CROSSFEED LINES MUST BE DRAINED."

On Control Lock:

- a. "CONTROL LOCK - REMOVE BEFORE STARTING ENGINES."
- b. If optional rudder lock is installed: add "RUDDER LOCK" to item "a".

Near Parking Brake:

- a. "PARKING BRAKE - TO APPLY, DEPRESS PEDALS, THEN PULL KNOB. TO RELEASE, PUSH IN KNOB, DO NOT DEPRESS PEDALS."

At Appropriate Locations:

- a. "TANK AND SUMP DRAINS."
- b. "CROSSFEED LINE DRAIN - DRAIN DAILY."
- c. "FUEL, 100/130 AVIATION GRADE MIN., USABLE - 50 GAL."
- d. If optional 40-gallon auxiliary tank system is installed:
"AUX FUEL, 100/130 AVIATION GRADE MIN., USABLE - 20 GAL."
- e. If optional 63-gallon auxiliary tank system is installed:
"AUX FUEL 100/130 AVIATION GRADE MIN., USABLE - 31.5 GAL."
- f. If optional wing locker fuel tanks are installed:
"TRANSFER FUEL, 100/130 AVIATION GRADE MIN., USABLE - 20 GAL."
- g. "STATIC PRESSURE ALTERNATE SOURCE →" "OPEN ↔ CLOSED"
- h. "AMP METER SELECT - L. ALT. - R. ALT. - BAT - VOLTS."
- i. "ALT FAILURE - L. ALT., R. ALT."

licability: Models 310R, and T310R.

quirement: Revise:

AD CESS 14 310/57 AFMOT

1. the **Limitations Section** of the aircraft's Aircraft Flight Manual (AFM) by incorporating the following:

"WARNING"

Severe icing may result from environmental conditions outside of those for which the aircraft is certificated.

Flight in freezing rain, freezing drizzle, or mixed icing conditions (super cooled liquid water and ice crystals) may result in:

- ice build-up on protected surfaces and exceed the capability of the ice protection system, or
- ice forming aft of the protected surfaces.

This ice may not be shed using the ice protection systems, and may seriously degrade the performance and controllability of the aircraft.

During flight, severe icing conditions that exceed those for which the aircraft is certificated shall be determined by the visual cues described below. If one or more of these visual cues exists, immediately request priority handling from Air Traffic Control to facilitate a route or an altitude change to exit the icing conditions. The cues are:

- unusually extensive ice accumulation on the airframe and windscreen in areas not normally observed to collect ice, and/or
- accumulation of ice on the upper surface of the wing aft of the protected area, and/or
- accumulation of ice on the engine nacelles and propeller spinners farther aft than normally observed.

Since the auto-pilot, when installed and operating, may mask tactile cues that indicate adverse changes in handling characteristics, use of the auto-pilot is prohibited when any of the visual cues specified above exist, or when unusual lateral trim requirements or auto-pilot trim warnings are encountered while the aircraft is in icing conditions.

All wing icing inspection lights must be operative prior to flight into known or forecast icing conditions at night. **This direction supersedes any relief provided by any Minimum Equipment List.**

ENGINE FAILURE DURING FLIGHT EMERGENCY PROCEDURES

SUPPLEMENT

TO

PILOT'S OPERATING HANDBOOK/OWNER'S MANUAL

FOR THE FOLLOWING CESSNA MODELS:

ALL T303, 310/T310, 320, 335, 340/340A

ALL 1976 THRU 1985 402B/402C, 404, 414/414A, 421C

SERIAL NO. 0712

REGISTRATION NO. N4WME

This supplement must be inserted in, or attached to, the latest version of the Pilot's Operating Handbook, or Owner's Manual for the above listed airplane models.

APPROVED BY
FAA APPROVED UNDER FAR 21 SUBPART J
The Cessna Aircraft Co.
Delegation Option Authorization DOA-100129-CE

Michael D. Kelly Executive Engineer
Wendell Cornett
Wendell Cornett

16 NOVEMBER 2001
DATE OF APPROVAL

APPROVED BY
FAA APPROVED UNDER FAR 21 SUBPART J
The Cessna Aircraft Co.
Delegation Option Authorization DOA-230428-CE

Stanley J. Carl Executive Engineer
STC

16 NOVEMBER 2001
DATE OF APPROVAL

COPYRIGHT © 2001
CESSNA AIRCRAFT COMPANY
WICHITA, KANSAS, USA

 Member of GAMA

SUPPLEMENT

ENGINE FAILURE DURING FLIGHT EMERGENCY PROCEDURES

Use the Log of Effective Pages to determine the current status of this supplement.

Pages affected by the current revision are indicated by an asterisk (*) preceding the page number.

Supplement Status	Date
Original	16 November 2001

LOG OF EFFECTIVE PAGES

Page	Page Status	Revision Number
1 thru 5/6	Original	0

AMPLIFIED EMERGENCY PROCEDURES

ENGINE INOPERATIVE PROCEDURES

ENGINE FAILURE DURING FLIGHT (Speed Above Air Minimum Control Speed)

WARNING

Level flight may not be possible for certain combinations of weight, temperature, and altitude. In any event, do not attempt an engine inoperative go-around after wing flaps have been extended beyond 15°.

ENGINE FAILURE DURING FLIGHT (Speed Below Air Minimum Control Speed)

WARNING

Level flight may not be possible for certain combinations of weight, temperature, and altitude. In any event, do not attempt an engine inoperative go-around after wing flaps have been extended beyond 15°.

ENGINE INOPERATIVE GO-AROUND

WARNING

Level flight may not be possible for certain combinations of weight, temperature, and altitude. In any event, do not attempt an engine inoperative go-around after wing flaps have been extended beyond 15°.

SECTION 4 NORMAL PROCEDURES

There are no changes to airplane normal procedures.

SECTION 5 PERFORMANCE

There are no changes to airplane performance.

SECTION 3 EMERGENCY PROCEDURES

TABLE OF CONTENTS

	Page		Page
INTRODUCTION	3-1	AMPLIFIED EMERGENCY	
EMERGENCY PROCEDURES		PROCEDURES	3-11
ABBREVIATED CHECKLIST	3-2	Single-Engine Airspeeds	
Engine Inoperative		For Safe Operation	3-11
Procedures	3-2	Engine Inoperative	
Fire Procedures	3-4A/3-4B	Procedures	3-12
Emergency Descent		Maximum Glide	3-18
Procedures	3-5	Fire Procedures	3-19
Emergency Landing		Emergency Descent	
Procedures	3-5	Procedures	3-21
Fuel System Emergency		Emergency Landing	
Procedures	3-8	Procedures	3-21
Electrical System		Fuel System Emergency	
Emergency Procedures	3-8	Procedures	3-26
Avionics Bus Failure	3-9	Electrical System	
Landing Gear Emergency		Emergency Procedures	3-26
Procedures	3-9	Avionics Bus Failure	3-27
Flight Instruments		Landing Gear Emergency	
Emergency Procedures	3-10	Procedures	3-27
Air Inlet or Filter		Flight Instruments	
Icing Emergency		Emergency Procedures	3-28
Procedures	3-10	Air Inlet or Filter	
Propeller Synchrophaser	3-10	Icing Emergency	
Emergency Exit Window	3-10	Procedures	3-29
Spins	3-10	Propeller	
		Synchrophaser	3-29
		Emergency Exit Window	3-29
		Spins	3-29

INTRODUCTION

Section 3 of the Pilot's Operating Handbook describes the recommended procedures for emergency situations. The first part of this section provides emergency procedural action required in an abbreviated checklist form. Amplification of the abbreviated checklist is presented in the second part of this section.

NOTE

Refer to Section 9 of this Pilot's Operating Handbook for amended operating limitations, operating procedures, performance data and other necessary information for airplanes equipped with specific options.

**EMERGENCY PROCEDURES
ABBREVIATED CHECKLIST
SINGLE-ENGINE AIRSPEEDS FOR SAFE OPERATION**

Conditions:	
1. Takeoff Weight 5500 Pounds	3. Standard Day, Sea Level
2. Landing Weight 5400 Pounds	
(1) Air Minimum Control Speed	80 KIAS
(2) Recommended Safe Single-Engine Speed	92 KIAS
(3) Best Single-Engine Angle-of-Climb Speed	95 KIAS
(4) Best Single-Engine Rate-of-Climb Speed (Flaps Up)	106 KIAS

Figure 3-1

ENGINE INOPERATIVE PROCEDURES

ENGINE SECURING PROCEDURE

1. Throttle - CLOSE.
2. Mixture - IDLE CUT-OFF.
3. Propeller - FEATHER.
4. Fuel Selector - OFF (Feel for Detent).
5. Auxiliary Fuel Pump - OFF.
6. Magneto Switches - OFF.
7. Propeller Synchrophaser - OFF (Optional System).
8. Alternator - OFF.
9. Cowl Flap - CLOSE.

ENGINE FAILURE DURING TAKEOFF (Speed Below 92 KIAS)

1. Throttles - CLOSE IMMEDIATELY.
2. Brakes - AS REQUIRED.

ENGINE FAILURE AFTER TAKEOFF (Speed Above 92 KIAS With Gear Up Or In Transit)

1. Mixtures - AS REQUIRED for flight altitude.
2. Propellers - FULL FORWARD.
3. Throttles - FULL FORWARD.
4. Landing Gear - CHECK UP.
5. Inoperative Engine:
 - a. Throttle - CLOSE.
 - b. Mixture - IDLE CUT-OFF.
 - c. Propeller - FEATHER.
6. Establish Bank - 5° toward operative engine.
7. Wing Flaps - UP, if extended, in small increments.
8. Climb To Clear 50-Foot Obstacle - 92 KIAS.
9. Climb At Best Single-Engine Rate-of-Climb Speed - 106 KIAS at sea level; 94 KIAS at 10,000 feet.
10. Trim Tabs - ADJUST 5° bank toward operative engine with approximately 1/2 ball slip indicated on the turn and bank indicator.
11. Cowl Flap - CLOSE (Inoperative Engine).
12. Inoperative Engine - SECURE as follows:
 - a. Fuel Selector - OFF (Feel For Detent).
 - b. Auxiliary Fuel Pump - OFF.
 - c. Magneto Switches - OFF.
 - d. Alternator - OFF.
13. As Soon As Practical - LAND.

ENGINE FAILURE DURING FLIGHT

1. Inoperative Engine - DETERMINE.
2. Operative Engine - ADJUST as required.

Before Securing Inoperative Engine:

3. Fuel Flow - CHECK. If deficient, position auxiliary fuel pump to ON.
4. Fuel Selectors - MAIN TANKS (Feel For Detent).
5. Fuel Quantity - CHECK.
6. Oil Pressure and Oil Temperature - CHECK.
7. Magneto Switches - CHECK.

If Engine Does Not Start, Secure as Follows:

8. Inoperative Engine - SECURE.
 - a. Throttle - CLOSE.
 - b. Mixture - IDLE CUT-OFF.
 - c. Propeller - FEATHER.
 - d. Fuel Selector - OFF (Feel For Detent).
 - e. Auxiliary Fuel Pump - OFF.
 - f. Magneto Switches - OFF.
 - g. Propeller Synchrophaser - OFF (Optional System).
 - h. Alternator - OFF.
 - i. Cowl Flap - CLOSE.
9. Operative Engine - ADJUST.
 - a. Power - AS REQUIRED.
 - b. Mixture - AS REQUIRED for flight altitude.
 - c. Fuel Selector - AS REQUIRED (Feel For Detent).
 - d. Auxiliary Fuel Pump - ON.
 - e. Cowl Flap - AS REQUIRED.
10. Trim Tabs - ADJUST 5° bank toward operative engine.
11. Electrical Load - DECREASE to minimum required.
12. As Soon As Practical - LAND.

ENGINE INOPERATIVE LANDING

1. Fuel Selector - MAIN TANK (Feel For Detent).
2. Auxiliary Fuel Pump - ON.
3. Alternate Air Control - IN.
4. Mixture - AS REQUIRED for flight altitude.
5. Propeller Synchrophaser - OFF (Optional System).
6. Propeller - FULL FORWARD.
7. Approach - 106 KIAS with excessive altitude.
8. Landing Gear - DOWN within gliding distance of field.
9. Wing Flaps - DOWN when landing is assured.
10. Speed - DECREASE below 93 KIAS only if landing is assured.
11. Air Minimum Control Speed - 80 KIAS.

ENGINE INOPERATIVE GO-AROUND (Speed Above 92 KIAS)

1. Throttle - FULL FORWARD.
2. Mixture - AS REQUIRED for flight altitude.
3. Landing Gear - UP.
4. Wing Flaps - UP if extended.
5. Cowl Flap - OPEN.
6. Climb at Best Single-Engine Rate-of-Climb Speed - 106 KIAS at sea level; 94 KIAS at 10,000 feet.
7. Trim Tabs - ADJUST 5° bank toward operative engine.

AIRSTART

Airplanes Without Optional Propeller Unfeathering System:

1. Magneto Switches - ON.
2. Fuel Selector - MAIN TANK (Feel For Detent).
3. Throttle - FORWARD approximately one inch.
4. Mixture - AS REQUIRED for flight altitude.
5. Propeller - FORWARD of detent.
6. Starter Button - PRESS.
7. Primer Switch - ACTIVATE.
8. Starter and Primer Switch - RELEASE when engine fires.
9. Mixture - AS REQUIRED.
10. Power - INCREASE after cylinder head temperature reaches 200°F.
11. Cowl Flap - AS REQUIRED.
12. Alternator - ON.

Airplanes With Optional Propeller Unfeathering System:

1. Magneto Switches - ON.
2. Fuel Selector - MAIN TANK (Feel For Detent).
3. Throttle - FORWARD approximately one inch.
4. Mixture - AS REQUIRED for flight altitude.
5. Propeller - FULL FORWARD.
6. Propeller - RETARD to detent when propeller reaches 1000 RPM.
7. Mixture - AS REQUIRED.
8. Power - INCREASE after cylinder head temperature reaches 200°F.
9. Cowl Flap - AS REQUIRED.
10. Alternator - ON.

BOTH ENGINES FAILURE (Gliding Procedures)

1. Wing Flaps - UP.
2. Landing Gear - UP.
3. Propellers - FEATHER.
4. Cowl Flaps - CLOSE.
5. Airspeed - 111 KIAS (See Figure 3-4).

FIRE PROCEDURES

FIRE ON THE GROUND (Engine Start, Taxi And Takeoff With Sufficient Distance Remaining To Stop)

1. Throttles - CLOSE.
2. Brakes - AS REQUIRED.
3. Mixtures - IDLE CUT-OFF.
4. Battery - OFF (Use Gang Bar).
5. Magnetos - OFF (Use Gang Bar).
6. Evacuate airplane as soon as practical.

INFLIGHT WING OR ENGINE FIRE

1. Both Auxiliary Fuel Pumps - OFF.
2. Appropriate Engine - SECURE.
 - a. Throttle - CLOSE.
 - b. Mixture - IDLE CUT-OFF.
 - c. Propeller - FEATHER.
 - d. Fuel Selector - OFF (Feel For Detent).
 - e. Magnetos - OFF.
 - f. Propeller Synchrophaser - OFF (Optional System).
 - g. Alternator - OFF.
 - h. Cowl Flap - CLOSE.
3. Cabin Heater - OFF.
4. Land and evacuate airplane as soon as practical.

INFLIGHT CABIN FIRE OR SMOKE

1. Electrical Load - REDUCE to minimum required.
2. Attempt to isolate the source of fire or smoke.
3. Wemacs - OPEN.
4. Cabin Air Controls - OPEN all vents including windshield defrost.
CLOSE if intensity of smoke increases.

CAUTION

Opening the foul weather window or cabin door will create a draft in the cabin and may intensify a fire.

5. Land and evacuate airplane as soon as practical.

EMERGENCY DESCENT PROCEDURES**PREFERRED PROCEDURE**

1. Throttles - IDLE.
2. Propellers - FULL FORWARD.
3. Mixtures - ADJUST for smooth operation with gradual enrichment as altitude is lost.
4. Wing Flaps - UP.
5. Landing Gear - UP.
6. Moderate Bank - INITIATE.
7. Airspeed - 220 KIAS.

IN TURBULENT ATMOSPHERIC CONDITIONS

1. Throttles - IDLE.
2. Propellers - FULL FORWARD.
3. Mixtures - ADJUST for smooth operation with gradual enrichment as altitude is lost.
4. Wing Flaps - DOWN 35°.
5. Landing Gear - DOWN.
6. Moderate Bank - INITIATE.
7. Airspeed - 138 KIAS.

EMERGENCY LANDING PROCEDURES**FORCED LANDING (With Power)**

1. Landing Site - CHECK. Overfly site at 100 KIAS and 15° flaps.
2. Landing Gear - DOWN if surface is smooth and hard.
 - a. Normal Landing - INITIATE. Keep nosewheel off ground as long as practical.
3. Landing Gear - UP if surface is rough or soft.
 - a. Select a smooth grass-covered runway, if possible.
 - b. Approach - 100 KIAS with 15° wing flaps.
 - c. All Switches Except Magnetos - OFF.
 - d. Cabin Door - UNLATCH prior to flare-out.
 - e. Mixtures - IDLE CUT-OFF.
 - f. Magneto Switches - OFF.
 - g. Fuel Selectors - OFF (Feel For Detent).
 - h. Landing Attitude - TAIL LOW.

FORCED LANDING (Complete Power Loss)

1. Mixtures - IDLE CUT-OFF.
2. Propellers - FEATHER.
3. Fuel Selectors - OFF (Feel For Detent).
4. All Switches Except Battery - OFF.
5. Approach - 111 KIAS.
6. If Smooth and Hard Surface:
 - a. Landing Gear - DOWN within gliding distance of field.
 - b. Wing Flaps - AS REQUIRED.
 - c. Battery Switch - OFF.
 - d. Cabin Door - UNLATCH prior to flare-out.
 - e. Normal Landing - INITIATE. Keep nosewheel off ground as long as practical.
7. If Rough or Soft Surface:
 - a. Select a smooth grass-covered runway, if possible.
 - b. Landing Gear - UP.
 - c. Wing Flaps - DOWN 15°.
 - d. Battery Switch - OFF.
 - e. Cabin Door - UNLATCH prior to flare-out.
 - f. Landing Attitude - TAIL LOW.

LANDING WITH FLAT MAIN GEAR TIRE

1. Landing Gear - Leave DOWN.
2. Fuel Selectors - SELECT the main tank on the same side as the flat tire to reduce fuel weight over affected tire before landing; feel for detent.
3. Fuel Selectors - MAIN TANKS (Feel For Detent).
4. Wind should be headwind or crosswind opposite the defective tire.
5. Wing Flaps - DOWN 35°.
6. In approach, align airplane with edge of runway opposite the defective tire, allowing room for a mild turn in the landing roll.
7. Land slightly wing low on the side of the inflated tire and lower the nosewheel to the ground immediately for positive steering.
8. Use full aileron in landing roll, to lighten the load on the defective tire.
9. Apply brakes only on the inflated tire, to minimize landing roll and maintain directional control.
10. Stop airplane to avoid further damage, unless active runway must be cleared for other traffic.

LANDING WITH DEFECTIVE MAIN GEAR

1. Fuel Selectors - SELECT the main tank on the same side as defective gear to reduce fuel weight over affected gear before landing; feel for detent.
2. Fuel Selectors - MAIN TANKS (Feel For Detent).
3. Wind - HEADWIND or crosswind opposite defective gear.
4. Landing Gear - DOWN.
5. Wing Flaps - DOWN 35°.
6. Approach - ALIGN AIRPLANE with the edge of runway opposite the defective landing gear.
7. Battery Switch - OFF.
8. Land wing low toward operative landing gear. Lower nosewheel immediately for positive steering.
9. Ground Loop - INITIATE into defective landing gear.
10. Mixtures - IDLE CUT-OFF.
11. Use full aileron in landing roll, to lighten the load on the defective gear.
12. Apply brakes only on the operative landing gear to hold desired rate of turn and shorten landing roll.
13. Fuel Selectors - OFF (Feel For Detent).
14. Airplane - EVACUATE.

LANDING WITH FLAT NOSE GEAR TIRE

1. Landing Gear - Leave DOWN.
2. Passengers and Baggage - MOVE AFT.
3. Approach - 100 KIAS with 15° wing flaps.
4. Landing Attitude - NOSE HIGH.
5. Hold nose off during landing roll.
6. Brakes - MINIMUM in landing roll.
7. Throttles - RETARD in landing roll.
8. Control Wheel - FULL AFT until airplane stops.
9. Minimize additional taxiing to prevent further damage.

LANDING WITH DEFECTIVE NOSE GEAR

1. If Smooth and Hard Surface:
 - a. Baggage and Passengers - MOVE AFT.
 - b. Select a smooth hard surface runway.
 - c. Landing Gear - DOWN.
 - d. Approach - 100 KIAS with 15° wing flaps.
 - e. All Switches Except Magnetos - OFF.
 - f. Landing Attitude - NOSE HIGH.
 - g. Mixtures - IDLE CUT-OFF.
 - h. Magneto Switches - OFF.
 - i. Nose - LOWER as speed dissipates.
2. If Rough or Sod Surface:
 - a. Select a smooth grass-covered runway, if possible.
 - b. Landing Gear - UP.
 - c. Approach - 100 KIAS with 15° wing flaps.
 - d. All Switches Except Magnetos - OFF.
 - e. Cabin Door - UNLATCH prior to flare-out.
 - f. Landing Attitude - TAIL LOW.
 - g. Mixtures - IDLE CUT-OFF.
 - h. Magneto Switches - OFF.
 - i. Fuel Selectors - OFF (Feel For Detent).

LANDING WITHOUT FLAPS (0° Extension)

1. Mixtures - AS REQUIRED for flight altitude.
2. Propellers - FULL FORWARD.
3. Fuel Selectors - MAIN TANKS (Feel For Detent).
4. Minimum Approach Speed - 105 KIAS (See Figure 5-26).
5. Landing Gear - DOWN.

DITCHING

1. Landing Gear - UP.
2. Approach - HEADWIND if high winds.
PARALLEL to SWELLS if light wind and heavy swells.
3. Wing Flaps - DOWN 35°.
4. Power - AS REQUIRED. (300 Feet Per Minute Descent).
5. Airspeed - 93 KIAS.
6. Attitude - DESCENT ATTITUDE through touchdown.

FUEL SYSTEM EMERGENCY PROCEDURES

ENGINE-DRIVEN FUEL PUMP FAILURE

1. Fuel Selector - MAIN TANK (Feel For Detent).
2. Auxiliary Fuel Pump - ON.
3. Cowl Flap - OPEN.
4. Mixture - ADJUST for smooth engine operation.
5. As Soon As Practical - LAND.
6. Fuel in auxiliary and opposite main tank is unusable.

ELECTRICAL SYSTEM EMERGENCY PROCEDURES

ALTERNATOR FAILURE (Single)

Indicated By Illumination Of Failure Light

1. Electrical Load - REDUCE.
2. If Circuit Breaker is Tripped:
 - a. Turn off affected alternator.
 - b. Reset affected alternator circuit breaker.
 - c. Turn on affected alternator switch.
 - d. If circuit breaker reopens, turn off alternator.
3. If Circuit Breaker does not Trip:
 - a. Select affected alternator on voltmeter and monitor output.
 - b. If output is normal and failure light remains on, disregard fail indication and have indicator checked after landing.
 - c. If output is insufficient, turn off alternator and reduce electrical load to one alternator capacity.
 - d. If complete loss of alternator output occurs, check field fuse and replace if necessary.
 - e. If an intermittent light indication accompanied by voltmeter fluctuation is observed, turn off affected alternator and reduce load to one alternator capacity.

ALTERNATOR FAILURE (Dual)**Indicated By Illumination Of Failure Lights And Low Voltage Light**

1. Electrical Load - REDUCE.
2. If Circuit Breakers are Tripped:
 - a. Turn off alternators.
 - b. Reset circuit breakers.
 - c. Turn on left alternator and monitor output on voltmeter.
 - d. If alternator is charging, leave it on. Disregard failure light if still illuminated.
 - e. If still inoperative, turn off left alternator.
 - f. Repeat steps c through e for right alternator.
 - g. If circuit breakers reopen, prepare to terminate flight.
3. If Circuit Breakers have not Tripped:
 - a. Turn off alternators.
 - b. Check field fuses and replace as required.
 - c. Turn on left alternator and monitor output on voltmeter.
 - d. If alternator is charging, leave it on. Disregard failure light if still illuminated.
 - e. If still inoperative, turn off left alternator.
 - f. Repeat steps c through e for right alternator.
 - g. If both still inoperative, turn off alternators and turn on emergency alternator field switch.
 - h. Repeat steps c through e for each alternator.
 - i. If still inoperative, turn off alternators and prepare to terminate flight.

AVIONICS BUS FAILURE

1. Emergency Avionics Power Switch - ON.

LANDING GEAR EMERGENCY PROCEDURES**LANDING GEAR WILL NOT EXTEND ELECTRICALLY**

1. Landing Gear Motor Circuit Breaker - CHECK IN with landing gear switch DOWN.
2. Landing Gear Motor Circuit Breaker - PULL.
3. Landing Gear Switch - NEUTRAL (Center).
4. Pilot's Seat - ADJUST as required.
5. Handcrank - EXTEND AND LOCK.
6. Rotate Crank - CLOCKWISE four turns past gear down lights on (Approximately 52 Turns).
7. Gear Down Lights - ON; Unlocked Light - OFF.
8. Gear Warning Horn - CHECK.
9. Handcrank - PUSH BUTTON and STOW.
10. As Soon As Practical - LAND.

LANDING GEAR WILL NOT RETRACT ELECTRICALLY

1. Do not try to retract manually.
2. Landing Gear - DOWN.
3. Gear Down Lights - ON; Unlocked Light - OFF.
4. Gear Warning Horn - CHECK.
5. As Soon As Practical - LAND.

FLIGHT INSTRUMENTS EMERGENCY PROCEDURES

VACUUM PUMP FAILURE (Attitude And Directional Gyros)

1. Failure indicated by left or right red failure button exposed on vacuum gage.
2. Automatic valve will select operative source.
3. Vacuum Pressure - CHECK proper vacuum from operative source.

OBSTRUCTION OR ICING OF STATIC SOURCE

1. Alternate Static Source - OPEN.
2. Excess Altitude and Airspeed - MAINTAIN to compensate for change in calibration (See Figures 5-2 and 5-4).

AIR INLET OR FILTER ICING EMERGENCY PROCEDURES

1. Alternate Air Control(s) - PULL OUT.
2. Power - INCREASE as required.
3. Mixtures(s) - LEAN as required.

PROPELLER SYNCHROPHASER

ENGINE INOPERATIVE PROCEDURES

1. Propeller Synchrophaser - OFF (Optional System).

SYNCHROPHASER FAILURE

1. Propeller Synchrophaser - OFF (Optional System).
2. Propeller Synchrophaser Circuit Breaker - PULL (Optional System).

EMERGENCY EXIT WINDOW

1. Emergency Release Ring Plastic Cover - PULL OFF.
2. Emergency Release Ring - PULL.
3. Emergency Exit Window - PUSH OUT at bottom of window with sustained force.

SPINS

1. Throttles - CLOSE IMMEDIATELY.
2. Ailerons - NEUTRALIZE.
3. Rudder - HOLD FULL RUDDER opposite the direction of rotation.
4. Control Wheel - FORWARD BRISKLY, 1/2 turn after applying full rudder.
5. Inboard Engine - INCREASE POWER to slow rotation. (If Necessary).

After rotation has stopped:

6. Rudder - NEUTRALIZE.
7. Inboard Engine (If used) - DECREASE POWER to equalize engines.
8. Control Wheel - PULL to recover from resultant dive. Apply smooth steady control pressure.

AMPLIFIED EMERGENCY PROCEDURES

NOTE

A complete knowledge of the procedures set forth in this section will enable the pilot to cope with various emergencies that can be encountered; however, this does not diminish the fact that the primary responsibility of the pilot is to maintain control of the airplane at all times. Good judgment and precise action are essential and can only be developed through frequent practice of emergency and simulated single-engine procedures. The pilot must have a thorough knowledge of all emergency procedures so that in the event of an emergency, reaction will be precise and done with confidence. This is required so the pilot can cope with the demands of an emergency situation.

SINGLE-ENGINE AIRSPEEDS FOR SAFE OPERATION

The most critical time for an engine failure condition in a multi-engine airplane is during a two or three second period late in the takeoff run while the airplane is accelerating to a safe engine failure speed. A detailed knowledge of recommended single-engine airspeeds is essential for safe operation of the airplane.

The airspeed indicator is marked with a red radial at the air minimum control speed and a blue radial at the best single-engine rate-of-climb speed to facilitate instant recognition. The following paragraphs present a detailed discussion of the problems associated with engine failures during takeoff.

AIR MINIMUM CONTROL SPEED

The multi-engine airplane must reach the air minimum control speed (80 KIAS) before full control deflections can counteract the adverse rolling and yawing tendencies associated with one engine inoperative and full power operation on the other engine. This speed is indicated by a red radial on the airspeed indicator.

RECOMMENDED SAFE SINGLE-ENGINE SPEED

Although the airplane is controllable at the air minimum control speed, the airplane performance is so far below optimum that continued flight near the ground is improbable. A more suitable recommended safe single-engine speed is 92 KIAS. At this speed, altitude can be maintained more easily while the landing gear is being retracted and the propeller is being feathered.

BEST SINGLE-ENGINE ANGLE-OF-CLIMB SPEED

The best single-engine angle-of-climb speed becomes important when there are obstacles ahead on takeoff. Once the best single-engine angle-of-climb speed is reached, altitude becomes more important than airspeed until the obstacle is cleared. The best single-engine angle-of-climb speed is approximately 95 KIAS with wing flaps and landing gear up.

BEST SINGLE-ENGINE RATE-OF-CLIMB SPEED

The best single-engine rate-of-climb speed becomes important when there are no obstacles ahead on takeoff, or when it is difficult to maintain or gain altitude in single-engine emergencies. The best single-engine rate-of-climb speed is 106 KIAS with wing flaps and landing gear up. This speed is indicated by a blue radial on the airspeed indicator.

The variations of wing flaps up best single-engine rate-of-climb speed with altitude are shown in Section 5. For best single-engine climb performance, the wings should be banked 5° toward the operative engine.

ENGINE INOPERATIVE PROCEDURES

ENGINE SECURING PROCEDURE

1. Throttle - CLOSE.
2. Mixture - IDLE CUT-OFF.
3. Propeller - FEATHER.
4. Fuel Selector - OFF (Feel For Detent).
5. Auxiliary Fuel Pump - OFF.
6. Magneto Switches - OFF.
7. Propeller Synchrophaser - OFF (Optional System).
8. Alternator - OFF.
9. Cowl Flap - CLOSE.

ENGINE FAILURE DURING TAKEOFF (Speed Below 92 KIAS)

1. Throttles - CLOSE IMMEDIATELY.
2. Brakes - AS REQUIRED.

NOTE

The distance required for the airplane to be accelerated from a standing start to 92 KIAS on the ground, and to decelerate to a stop with heavy braking, is presented in the Accelerate Stop Distance Chart in Section 5 for various combinations of conditions.

ENGINE FAILURE AFTER TAKEOFF (Speed Above 92 KIAS With Gear Up Or In Transit)

1. Mixtures - AS REQUIRED for flight altitude.
2. Propellers - FULL FORWARD.
3. Throttles - FULL FORWARD.
4. Landing Gear - CHECK UP.
5. Inoperative Engine:
 - a. Throttle - CLOSE.
 - b. Mixture - IDLE CUT-OFF.
 - c. Propeller - FEATHER.
6. Establish Bank - 5° toward operative engine.
7. Wing Flaps - UP, if extended, in small increments.
8. Climb to Clear 50-Foot Obstacle - 92 KIAS.

9. Climb at Best Single-Engine Rate-of-Climb Speed - 106 KIAS at sea level; 94 KIAS at 10,000 feet.
10. Trim Tabs - ADJUST 5° bank toward operative engine with approximately 1/2 ball slip indicated on the turn and bank indicator.
11. Cowl Flap - CLOSE (Inoperative Engine).
12. Inoperative Engine - SECURE as follows:
 - a. Fuel Selector - OFF (Feel For Detent).
 - b. Auxiliary Fuel Pump - OFF.
 - c. Magneto Switches - OFF.
 - d. Alternator Switch - OFF.
13. As Soon as Practical - LAND.

Upon engine failure after reaching 92 KIAS on takeoff, the multi-engine pilot has a significant advantage over a single-engine pilot, for he has a choice of stopping or continuing the takeoff. This would be similar to the choice facing a single-engine pilot who has suddenly lost slightly more than half of his takeoff power. In this situation, the single-engine pilot would be extremely reluctant to continue the takeoff if he had to climb over obstructions. However, if the failure occurred at an altitude as high or higher than surrounding obstructions, he would feel free to maneuver for a landing back at the airport.

Fortunately, the airplane accelerates through this "area of decision" in just a few seconds. However, to make an intelligent decision in this type of emergency, one must consider the field length, obstruction height, field elevation, air temperature, headwind, and takeoff weight. The flight paths illustrated in Figure 3-2 indicate that the "go no-go area of decision" is bounded by: (1) the point at which 92 KIAS is reached and (2) the point where the obstruction altitude is reached. An engine failure in this area requires an immediate decision. Beyond this area, the airplane, within the limitations of single-engine climb performance shown in Section 5, may be maneuvered to a landing back at the airport.

ENGINE FAILURE DURING TAKEOFF GO NO-GO DECISION

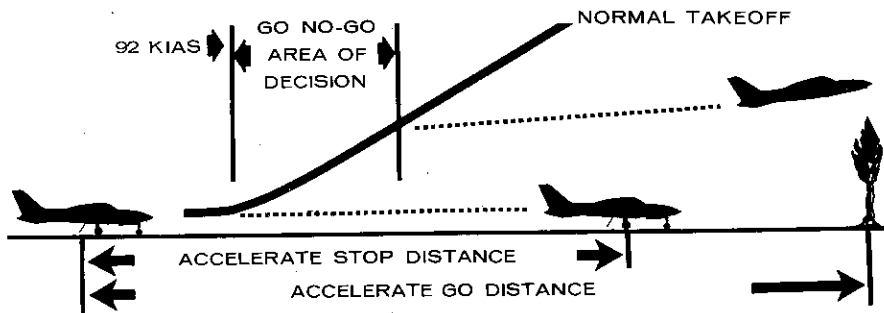

Figure 3-2

At sea level standard day, with zero wind and 5500 pounds weight, the distance to accelerate to 92 KIAS and stop is 3645 feet, while the total unobstructed distance required to takeoff and climb over a 50-foot obstacle after an engine failure at 92 KIAS is 3645 feet. This total distance over an obstacle can be reduced slightly under more favorable conditions of weight, headwind, or obstruction height. However, it is recommended that in most cases it would be better to discontinue the takeoff, since any slight mismanagement of single-engine procedure would more than offset the small distance advantage offered by continuing the takeoff. Still higher field elevations will cause the engine failure takeoff distance to lengthen disproportionately until the altitude is reached where a successful takeoff is improbable unless the airspeed and height above the runway at engine failure are great enough to allow a slight deceleration and altitude loss while the airplane is being prepared for a single-engine climb.

During single-engine takeoff procedures over an obstacle, only one condition presents any appreciable advantage; this is headwind. A decrease of approximately 6% in ground distance required to clear a 50-foot obstacle can be gained for each 10 knots of headwind. Excessive speed above best single-engine rate-of-climb speed at engine failure is not nearly as advantageous as one might expect since deceleration is rapid and ground distance is used up quickly at higher speeds while the airplane is being cleaned up for climb. However, the extra speed is important for controllability.

The following facts should be used as a guide at the time of engine failure: (1) discontinuing a takeoff upon engine failure is advisable under most circumstances; (2) altitude is more valuable to safety after takeoff than is airspeed in excess of the best single-engine rate-of-climb speed since excess airspeed is lost much more rapidly than is altitude; (3) climb or continued level flight at moderate altitude is improbable with the landing gear extended and the propeller windmilling; (4) in no case should the airspeed be allowed to fall below the best single-engine angle-of-climb speed, even though altitude is lost, since this speed will always provide a better chance of climb, or a smaller altitude loss, than any lesser speed. The single-engine best rate-of-climb speed will provide the best chance for climb or the least altitude loss, and is preferable unless there are obstructions which make a steep climb necessary.

WARNING

The propeller on the inoperative engine must be feathered, landing gear retracted and wing flaps up or continued flight may be impossible.

Single-engine procedures should be practiced in anticipation of an emergency. This practice should be conducted at a safe altitude, with full power operation on both engines, and should be started at a safe speed of at least 105 KIAS. As recovery ability is gained with practice, the starting speed may be lowered in small increments until the feel of the airplane in emergency conditions is well known. It should be noted that as the speed is reduced, directional control becomes more difficult. Emphasis should be placed on stopping the initial large yaw angles by the IMMEDIATE application of rudder supplemented by banking slightly away from the yaw. Practice should be continued until: (1) an instinctive corrective reaction is developed and the corrective procedure is automatic and, (2) airspeed, altitude, and heading can be maintained easily while the airplane is being

RPM TO SIMULATE CRITICAL (LEFT) ENGINE INOPERATIVE AND FEATHERED

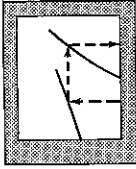

- CONDITIONS:
 1. Propellers in Low Pitch (Full Forward Position).
 2. Manifold Pressure Adjusted to Obtain Proper RPM.

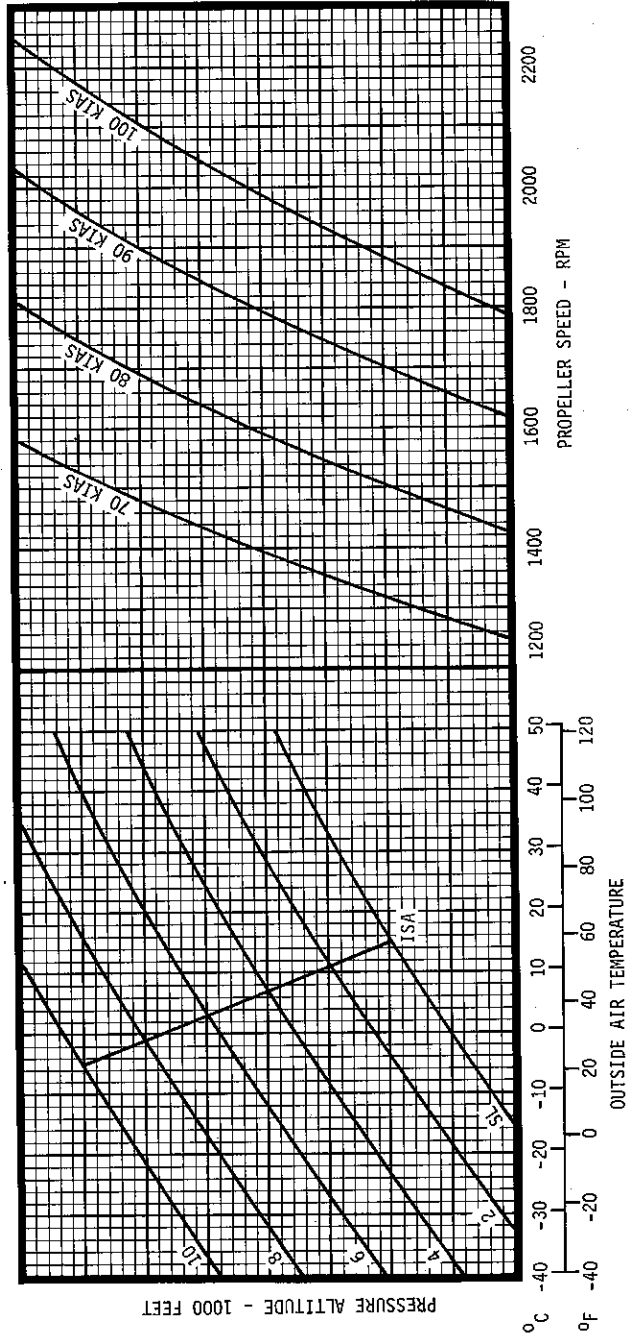

Figure 3-3

prepared for a climb. In order to simulate an engine failure, set both engines at full power operation; then at a chosen speed, pull the throttle control of one engine to idle, and proceed with single-engine emergency procedures. Simulated single-engine flight characteristics can be practiced by setting propeller RPM to simulate a critical engine inoperative condition as shown in Figure 3-3.

ENGINE OVERSPEED

Should an overspeed condition occur, the pilot should reduce airspeed as quickly as possible by closing both throttles. On reaching an airspeed below 120 KIAS and above the single-engine rate-of-climb speed (blue radial), set the RPM control on the overspeeding engine for feather. If propeller will not feather, the power on the normally operating engine should be advanced to maximum and the power on the overspeeding engine should be advanced to 50 RPM below the maximum allowable RPM (red line). Maintain the best single-engine rate-of-climb speed (blue radial) and land as soon as practical. This will provide more than zero thrust at altitudes up to approximately 10,000 feet. During landing, the application of partial throttle on the malfunctioning engine (within limits of the tachometer red line) will minimize asymmetrical thrust.

ENGINE FAILURE DURING FLIGHT

1. Inoperative Engine - DETERMINE. Idle engine same side as idle foot.
2. Operative Engine - ADJUST as required.

Before Securing Inoperative Engine:

3. Fuel Flow - CHECK. If deficient, position auxiliary fuel pump switch to ON.
4. Fuel Selectors - MAIN TANKS (Feel For Detent).
5. Fuel Quantity - CHECK. Switch to opposite MAIN TANK if necessary.
6. Oil Pressure and Oil Temperature - CHECK. Shutdown engine if oil pressure is low.
7. Magneto Switches - CHECK.
8. Mixture - ADJUST until evidence of engine firing. Continue to adjust for smooth operation.

If Engine Does Not Start, Secure as Follows:

9. Inoperative Engine - SECURE.
 - a. Throttle - CLOSE.
 - b. Mixture - IDLE CUT-OFF.
 - c. Propeller - FEATHER.
 - d. Fuel Selector - OFF (Feel For Detent).
 - e. Auxiliary Fuel Pump - OFF.
 - f. Magneto Switches - OFF.
 - g. Propeller Synchrophaser - OFF (Optional System).
 - h. Alternator Switch - OFF.
 - i. Cowl Flap - CLOSE.
10. Operative Engine - ADJUST.
 - a. Power - AS REQUIRED.
 - b. Mixture - AS REQUIRED for flight altitude.
 - c. Fuel Selector - AS REQUIRED (Feel For Detent).

NOTE

Auxiliary fuel on the side of the failed engine is unusable.

NOTE

Position operative engine fuel selector to MAIN TANK and feel for detent if below 1000 feet AGL or if nearest airport is within range of fuel remaining in MAIN TANK. If necessary, range can be extended by using wing locker fuel, opposite main fuel or auxiliary fuel on the side of the operative engine. Crossfeed as required to maintain lateral balance.

- d. Auxiliary Fuel Pump - ON.
- e. Cowl Flap - AS REQUIRED.
- 10. Trim Tabs - ADJUST 5° bank toward operative engine.
- 11. Electrical Load - DECREASE to minimum required.
- 12. As Soon As Practical - LAND.

ENGINE INOPERATIVE LANDING

- 1. Fuel Selector - MAIN TANK (Feel For Detent).
- 2. Auxiliary Fuel Pump - ON.
- 3. Alternate Air Control - IN.
- 4. Mixture - AS REQUIRED for flight altitude.
- 5. Propeller Synchrophaser - OFF (Optional System).
- 6. Propeller - FULL FORWARD.
- 7. Approach at 106 KIAS with excessive altitude.
- 8. Landing Gear - DOWN within gliding distance of field.
- 9. Wing Flaps - DOWN when landing is assured.
- 10. Decrease speed below 93 KIAS only if landing is assured.
- 11. Air Minimum Control Speed - 80 KIAS.

ENGINE INOPERATIVE GO-AROUND

- 1. If absolutely necessary and speed is above 92 KIAS, increase engine speed to 2700 RPM and apply full throttle.
- 2. Mixture - AS REQUIRED for flight altitude.
- 3. Landing Gear - UP.
- 4. Wing Flaps - UP if extended.
- 5. Cowl Flap - OPEN.
- 6. Climb at 106 KIAS at sea level; 94 KIAS at 10,000 feet (95 KIAS With Obstacles Directly Ahead).
- 7. Trim Tabs - ADJUST 5° bank toward operative engine.

AIRSTART (After Feathering)

Airplanes Without Optional Propeller Unfeathering System:

- 1. Magneto Switches - ON.
- 2. Fuel Selector - MAIN TANK (Feel For Detent).
- 3. Throttle - FORWARD approximately one inch.
- 4. Mixture - AS REQUIRED for flight altitude.
- 5. Propeller - FORWARD of detent.
- 6. Starter Button - PRESS.
- 7. Primer Switch - ACTIVATE.
- 8. Starter and Primer Switch - RELEASE when engine fires.
- 9. Mixture - AS REQUIRED.

10. Power - INCREASE after cylinder head temperature reaches 200°F.
11. Cowl Flap - AS REQUIRED.
12. Alternator - ON.

NOTE

If start is unsuccessful, turn inoperative engine magneto switches OFF, retard mixture to IDLE CUT-OFF, open throttle fully, and engage starter for several revolutions. Then repeat airstart procedures.

Airplanes With Optional Propeller Unfeathering System:

1. Magneto Switches - ON.
2. Fuel Selector - MAIN TANK (Feel For Detent).
3. Throttle - FORWARD approximately one inch.
4. Mixture - AS REQUIRED for flight altitude.
5. Propeller - FULL FORWARD.

NOTE

The propeller will automatically windmill when the propeller lever is moved out of the FEATHER position.

6. Propeller - RETARD to detent when propeller reaches 1000 RPM.
7. Mixture - AS REQUIRED.
8. Power - INCREASE after cylinder head temperature reaches 200°F.
9. Cowl Flap - AS REQUIRED.
10. Alternator - ON.

BOTH ENGINES FAILURE (Gliding Procedure)

1. Wing Flaps - UP.
2. Landing Gear - UP.
3. Propellers - FEATHER.
4. Cowl Flaps - CLOSE.
5. Airspeed - 111 KIAS (See Figure 3-4).

MAXIMUM GLIDE

In the event of an all engines failure condition, maximum gliding distance can be obtained by feathering both propellers, and maintaining approximately 111 KIAS with landing gear and wing flaps up. The speed which provides the "absolute maximum" glide distance varies with weight as shown in Figure 3-4.

WARNING

FOR THIS AIRPLANE TO CONTINUE FLIGHT WITH AN INOPERATIVE ENGINE, THE GEAR AND FLAPS MUST BE RETRACTED, THE PROPELLER ON THE INOPERATIVE ENGINE MUST BE FEATHERED, AIR SPEED MUST BE MAINTAINED AT OR ABOVE BEST RATE OF CLIMB SPEED, AND THE AIRPLANE MAINTAINED AND OPERATED IN ACCORDANCE WITH ALL OTHER SPECIFIED REQUIREMENTS. THE PILOT MUST BE RATED AND CURRENT IN MULTI-ENGINE PROCEDURES

0890018-4

MAXIMUM GLIDE**CONDITIONS:**

1. Landing Gear - UP
2. Wing Flaps - UP.
3. Propellers - FEATHERED.
4. Cowl Flaps - CLOSED.
5. Best Glide Speed.
6. Zero Wind

BEST GLIDE SPEED

WEIGHT POUNDS	KIAS
4700	102
5100	107
5500	111

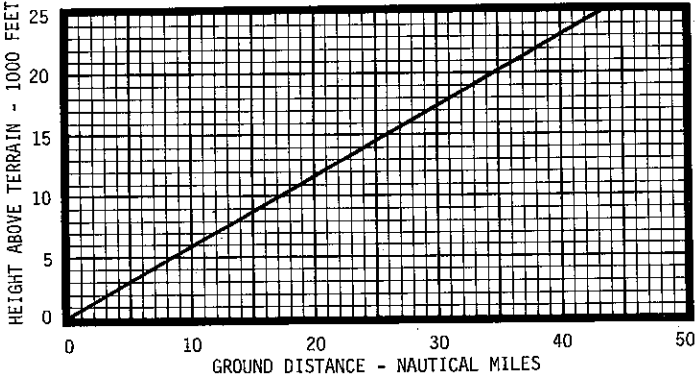
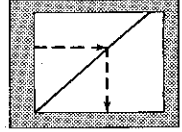

Figure 3-4

FIRE PROCEDURES

Refer to Section 9 if Fire Detection and Extinguishing System is installed.

FIRE ON THE GROUND (Engine Start, Taxi And Takeoff With Sufficient Distance Remaining To Stop)

1. Throttles - CLOSE.
2. Brakes - AS REQUIRED.
3. Mixtures - IDLE CUT-OFF.
4. Battery - OFF (Use Gang Bar).
5. Magnetos - OFF (Use Gang Bar).
6. Evacuate airplane as soon as practical.

INFLIGHT WING OR ENGINE FIRE

1. Both Auxiliary Fuel Pumps - OFF.
2. Appropriate Engine - SECURE.
 - a. Throttle - CLOSE.
 - b. Mixture - IDLE CUT-OFF.
 - c. Propeller - FEATHER.
 - d. Fuel Selector - OFF (Feel For Detent).
 - e. Magnetos - OFF.
 - f. Propeller Synchronphaser - OFF (Optional System).

- g. Alternator - OFF.
- h. Cowl Flap - CLOSE.
3. Cabin Heater - OFF.
4. Land and evacuate airplane as soon as practical.

INFLIGHT CABIN FIRE OR SMOKE

1. Electrical Load - REDUCE to minimum required.
2. Attempt to isolate the source of fire or smoke.
3. Wemacs - OPEN.
4. Cabin Air Controls - OPEN all vents including windshield defrost. CLOSE if intensity of smoke increases.

CAUTION

Opening the foul weather window or cabin door will create a draft in the cabin and may intensify a fire.

5. Land and evacuate airplane as soon as practical.

SUPPLEMENTARY INFORMATION CONCERNING AIRPLANE FIRES

With the use of modern installation techniques and material, the probability of an airplane fire occurring in your airplane is extremely remote. However, in the event a fire is encountered, the following information will be helpful in dealing with the emergency as quickly and safely as possible.

The preflight checklist is provided to aid the pilot in detecting conditions which could contribute to an airplane fire. As a fire requires both fuel and an ignition source, close preflight inspection should be given to the engine compartment and wing leading edge and lower surfaces. Leaks in the fuel system, oil system, or exhaust system can lead to a ground or airborne fire.

NOTE

Flight should not be attempted with known fuel, oil or exhaust leaks. The presence of fuel, unusual oil or exhaust stains may be an indication of system leaks and should be carefully investigated prior to flight.

If an airplane fire is discovered on the ground or during takeoff, but prior to committed flight, the airplane is to be landed and/or stopped and the passengers and crew evacuated as soon as practical.

Fires originating inflight must be controlled as quickly as possible in an attempt to prevent major structural damage. Both auxiliary fuel pumps should be turned off to reduce pressure on the total fuel system (each auxiliary pump pressurizes a crossfeed line to the opposite fuel selector). The engine on the wing in which the fire exists should be shut down and its fuel shut off even though the fire may not have originated in the fuel system. The cabin heater draws fuel from the crossfeed system and should also be turned off. Descent for landing should be initiated immediately.

An open cabin door or foul weather window produces a low pressure in the cabin. To avoid drawing the fire into the cabin, the cabin door and foul weather window should be kept closed. This condition is aggravated with the landing gear and flaps extended. Therefore, the pilot should lower the gear as late in the landing approach as possible. A no-flap landing should also be attempted if practical.

A fire or smoke in the cabin should be controlled by identifying and shutting down the faulty system. Smoke may be removed by opening the cabin air controls and wemacs. If the smoke increases in intensity when the air controls are opened, they should be closed as this indicates a possible fire in the heater or nose compartment. When the smoke is intense, the pilot may choose to expel the smoke through the foul weather window. The foul weather window should be closed immediately if the fire becomes more intense when the window is opened.

EMERGENCY DESCENT PROCEDURES

PREFERRED PROCEDURE

1. Throttles - IDLE.
2. Propellers - FULL FORWARD.
3. Mixtures - ADJUST for smooth operation with gradual enrichment as altitude is lost.
4. Wing Flaps - UP.
5. Landing Gear - UP.
6. Moderate Bank - INITIATE until descent attitude has been established.
7. Airspeed - 220 KIAS.

IN TURBULENT ATMOSPHERIC CONDITIONS

1. Throttles - IDLE.
2. Propellers - FULL FORWARD.
3. Mixtures - ADJUST for smooth operation with gradual enrichment as altitude is lost.
4. Wing Flaps - DOWN 35°.
5. Landing Gear - DOWN.
6. Moderate Bank - INITIATE until descent attitude has been established.
7. Airspeed - 138 KIAS.

EMERGENCY LANDING PROCEDURES

FORCED LANDING (With Power)

1. Drag over selected field with wing flaps 15° and 100 KIAS noting type of terrain and obstructions.
2. Plan a wheels-down landing if surface is smooth and hard.
 - a. Execute a normal landing, keeping nosewheel off ground until speed is decreased.
3. If terrain is rough or soft, plan a wheels-up landing as follows:
 - a. Select a smooth grass-covered runway, if possible.
 - b. Approach at 100 KIAS with wing flaps down only 15°.
 - c. All Switches Except Magneto Switches - OFF.

- d. Cabin Door - UNLATCH prior to flare-out.

NOTE

Be prepared for a mild tail buffet as the cabin door is opened.

- e. Mixtures - IDLE CUT-OFF.
f. Magneto Switches - OFF.
g. Fuel Selectors - OFF (Feel For Detent).
h. Land in a slightly tail-low attitude.

NOTE

On smooth sod with landing gear retracted, the airplane will slide straight ahead about 500 feet with very little damage.

FORCED LANDING (Complete Power Loss)

1. Mixtures - IDLE CUT-OFF.
2. Propellers - FEATHER.
3. Fuel Selectors - OFF (Feel For Detent).
4. All Switches Except Battery Switch - OFF.
5. Approach at 111 KIAS.
6. If field is smooth and hard, plan a landing as follows:
 - a. Landing Gear - DOWN within gliding distance of field.
 - b. Wing Flaps - EXTEND as necessary within gliding distance of field.
 - c. Battery Switch - OFF.
- d. Cabin Door - UNLATCH prior to flare-out.

NOTE

Be prepared for a mild tail buffet as the cabin door is opened.

- e. Make a normal landing, keeping nosewheel off the ground as long as practical.
7. If field is rough or soft, plan a wheels-up landing as follows:
 - a. Select a smooth, grass-covered runway if possible.
 - b. Landing Gear - UP.
 - c. Approach at 97 KIAS with wing flaps down only 15°.
 - d. Battery Switch - OFF.
 - e. Cabin Door - UNLATCH prior to flare-out.

NOTE

Be prepared for a mild tail buffet as the cabin door is opened.

- f. Land in a slightly tail-low attitude.

NOTE

On smooth sod with landing gear retracted, the airplane will slide straight ahead about 500 feet with very little damage.

LANDING WITH FLAT MAIN GEAR TIRE

If a blowout occurs during takeoff, proceed as follows:

1. Landing Gear - Leave DOWN.

NOTE

Do not attempt to retract the landing gear if a main gear tire blowout occurs. The main gear tire may be distorted enough to bind the main gear strut within the wheel well and prevent later extension.

2. Fuel Selectors - Turn to main tank on same side as defective tire and feel for detent. Proceed to destination to reduce fuel load.

NOTE

Fuel should be used from this tank first, to lighten the load on the wing, prior to attempting a landing if inflight time permits. However, an adequate supply of fuel should be left in this tank so that it may be used during landing.

3. Fuel Selectors - Left Engine - LEFT MAIN (Feel For Detent).
Right Engine - RIGHT MAIN (Feel For Detent).
4. Select a runway with a crosswind from the side opposite the defective tire, if a crosswind landing is required.
5. Wing Flaps - DOWN, extend flaps to 35°.
6. In approach, align airplane with edge of runway opposite the defective tire, allowing room for a mild turn in the landing roll.
7. Land slightly wing-low on the side of inflated tire and lower nosewheel to ground immediately for positive steering.
8. Use full aileron in landing roll to lighten load on defective tire.
9. Apply brakes only on the inflated tire, to minimize landing roll and maintain directional control.
10. Stop airplane to avoid further damage, unless active runway must be cleared for other traffic.

LANDING WITH DEFECTIVE MAIN GEAR

1. Fuel Selectors - Turn to main tank on same side as defective tire and feel for detent. Proceed to destination to reduce fuel load.

NOTE

Fuel should be used from this tank first, to lighten the load on the wing, prior to attempting a landing if in-flight time permits. However, an adequate supply of fuel should be left in this tank so that it may be used during landing.

2. Fuel Selectors - Left Engine - LEFT MAIN (Feel For Detent).
Right Engine - RIGHT MAIN (Feel For Detent).
3. Select a wide, hard surface runway, or if necessary, a wide sod runway. Select a runway with crosswind from the side opposite the defective landing gear, if a crosswind landing is necessary.
4. Landing Gear - DOWN.
5. Wing Flaps - DOWN 35°.
6. In approach, align airplane with edge of runway opposite the defective landing gear, allowing room for a ground-loop in landing roll.
7. Battery Switch - OFF.
8. Land slightly wing-low toward the operative landing gear and lower the nosewheel immediately for positive steering.
9. Start moderate ground-loop into defective landing gear until airplane stops.
10. Mixtures - IDLE CUT-OFF.
11. Use full aileron in landing roll to lighten the load on the defective landing gear.
12. Apply brakes only on the operative landing gear to maintain desired rate of turn and minimize the landing roll.
13. Fuel Selectors - OFF (Feel For Detent).
14. Evacuate the airplane as soon as it stops.

LANDING WITH FLAT NOSE GEAR TIRE

If a blowout occurred on the nose gear tire during takeoff, proceed as follows:

1. Landing Gear - Leave DOWN.

NOTE

Do not attempt to retract the landing gear if a nose gear tire blowout occurs. The nose gear tire may be distorted enough to bind the nosewheel strut within the wheel well and prevent later extension.

2. Move disposable load to baggage area and passengers to available rear seat space.
3. Approach - 100 KIAS with 15° wing flaps.
4. Land in a nose-high attitude with or without power.
5. Maintain back pressure on control wheel to hold nosewheel off the ground in landing roll.

6. Use minimum braking in landing roll.
7. Throttles - RETARD in landing roll.
8. As landing roll speed diminishes, hold control wheel fully aft until airplane is stopped.
9. Avoid further damage by holding additional taxi to a minimum.

LANDING WITH DEFECTIVE NOSE GEAR

1. If Smooth and Hard Surface:
 - a. Move disposable load to baggage area and passengers to available rear seat space.
 - b. Select a smooth hard surface runway.
 - c. Landing Gear - DOWN.
 - d. Approach at 100 KIAS with wing flaps down only 15°.
 - e. All Switches Except Magneto Switches - OFF.
 - f. Land in a slightly nose-high attitude.
 - g. Mixtures - IDLE CUT-OFF.
 - h. Magneto Switches - OFF.
 - i. Hold nose off throughout ground roll. Lower gently as speed dissipates.
2. If Rough or Sod Surface:

NOTE

This procedure will produce a minimum amount of airplane damage on smooth runways. This procedure is also recommended for short, rough or uncertain field conditions where passenger safety, rather than minimum airplane damage is the prime consideration.

- a. Select a smooth grass-covered runway, if possible.
- b. Landing Gear - UP.
- c. Approach at 100 KIAS with wing flaps down only 15°.
- d. All Switches Except Magneto Switches - OFF.
- e. Cabin Door - UNLATCH prior to flare-out.

NOTE

Be prepared for a mild tail buffet as the cabin door is opened.

- f. Land in a slightly tail-low attitude.
- g. Mixtures - IDLE CUT-OFF.
- h. Magneto Switches - OFF.
- i. Fuel Selectors - OFF (Feel For Detent).

LANDING WITHOUT FLAPS (0° Extension)

1. Mixtures - AS REQUIRED for flight altitude.
2. Propellers - FULL FORWARD.
3. Fuel Selectors - MAIN TANKS (Feel For Detent).
4. Minimum Approach Speed - 105 KIAS (See Figure 5-26).
5. Landing Gear - DOWN.

DITCHING

1. Landing Gear - UP.
2. Plan approach into wind if winds are high and seas are heavy. With heavy swells and light wind, land parallel to swells, being careful not to allow wing tips to hit first.
3. Wing Flaps - DOWN 35°.
4. Carry sufficient power to maintain approximately 300 feet per minute rate-of-descent.
5. Airspeed - 93 KIAS at 4600 pounds weight.
6. Maintain a continuous descent until touchdown to avoid flaring and touching down tail-first, pitching forward sharply, and decelerating rapidly. Strive for initial contact at fuselage area below rear cabin section (point of maximum longitudinal curvature of fuselage).

NOTE

The airplane has not been flight tested in actual ditchings, thus the above recommended procedure is based entirely on the best judgment of Cessna Aircraft Company.

FUEL SYSTEM EMERGENCY PROCEDURES

ENGINE-DRIVEN FUEL PUMP FAILURE

1. Fuel Selector - MAIN TANK (Feel For Detent).
2. Auxiliary Fuel Pump - ON.
3. Cowl Flap - OPEN.
4. Mixture - ADJUST for smooth engine operation.
5. As Soon as Practical - LAND.
6. Fuel in auxiliary and opposite main tank is unusable.

NOTE

If both an engine-driven fuel pump and an auxiliary fuel pump fail on the same side of the airplane, the failing engine cannot be supplied with fuel from the opposite main tank since that auxiliary fuel pump will operate on the low pressure setting as long as the corresponding engine-driven fuel pump is operative.

ELECTRICAL SYSTEM EMERGENCY PROCEDURES

ALTERNATOR FAILURE (Single)

Indicated By Illumination Of Failure Light

1. Electrical Load - REDUCE.
2. If Circuit Breaker is Tripped:
 - a. Turn off affected alternator.
 - b. Reset affected alternator circuit breaker.
 - c. Turn on affected alternator switch.
 - d. If circuit breaker reopens, turn off alternator.

3. If Circuit Breaker does not Trip:
 - a. Select affected alternator on voltmeter and monitor output.
 - b. If output is normal and failure light remains on, disregard fail indication and have indicator checked after landing.
 - c. If output is insufficient, turn off alternator and reduce electrical load to one alternator capacity.
 - d. If complete loss of alternator output occurs, check field fuse and replace if necessary. Spare fuses are located in the glove box.
 - e. If an intermittent light indication accompanied by voltmeter fluctuation is observed, turn off affected alternator and reduce load to one alternator capacity.

ALTERNATOR FAILURE (Dual)

Indicated By Illumination Of Failure Lights And Low Voltage Light

1. Electrical Load - REDUCE.
2. If Circuit Breakers are Tripped:
 - a. Turn off alternators.
 - b. Reset circuit breakers.
 - c. Turn on left alternator and monitor output on voltmeter.
 - d. If alternator is charging, leave it on. Disregard failure light if still illuminated.
 - e. If still inoperative, turn off left alternator.
 - f. Repeat steps c through e for right alternator.
 - g. If circuit breakers reopen, prepare to terminate flight.
3. If Circuit Breakers have not Tripped:
 - a. Turn off alternators.
 - b. Check field fuses and replace if necessary. Spare fuses are located in the glove box.
 - c. Turn on left alternator and monitor output on voltmeter.
 - d. If alternator is charging, leave it on. Disregard failure light if still illuminated.
 - e. If still inoperative, turn off left alternator.
 - f. Repeat steps c through e for right alternator.
 - g. If both alternators are still inoperative, turn off alternators and turn on emergency alternator field switch.
 - h. Repeat steps c through e for each alternator.
 - i. If still inoperative, turn off alternators and prepare to terminate flight.

AVIONICS BUS FAILURE

1. Emergency Avionics Power Switch - ON.

LANDING GEAR EMERGENCY PROCEDURES

LANDING GEAR WILL NOT EXTEND ELECTRICALLY

When the landing gear will not extend electrically, it may be extended manually in accordance with the following steps:

NOTE

The handcrank handle must be stowed in its clip before the gear will operate electrically. When the handle is placed in the operating position, it disengages the landing gear motor from the actuator gear.

1. Before proceeding manually, check landing gear motor circuit breaker with landing gear switch DOWN. If circuit breaker is tripped, allow 3 minutes for it to cool before resetting.
2. If Landing Gear Motor Circuit Breaker is Not Tripped - PULL.
3. Landing Gear Switch - NEUTRAL (Center).
4. Pilot's Seat - TILT full aft (Standard Seat).
RAISE (Optional Seat).
5. Handcrank - EXTEND and LOCK (See Figure 7-13).
6. Rotate Crank - CLOCKWISE four turns past the point where the gear down lights illuminate (Approximately 52 Turns).

WARNING

Maintain a secure grasp on the handcrank during manual extension of the gear. Never release the handcrank to let it turn freely of its own accord. If the handle is accidentally released, do not attempt to regrasp it until the handle stops revolving.

7. Gear Down Lights - ON; Unlocked Light - OFF.
8. Gear Warning Horn - CHECK with throttle retarded.
9. Handcrank - PUSH BUTTON and STOW.
10. As Soon as Practical - LAND.

LANDING GEAR WILL NOT RETRACT ELECTRICALLY:

1. Do not try to retract manually.

NOTE

The landing gear should never be retracted with the manual system, as undue loads will be imposed and cause excessive wear on the cranking mechanism.

2. Landing Gear - DOWN.
3. Gear Down Lights - ON; Unlocked Light - OFF.
4. Gear Warning Horn - CHECK.
5. As Soon as Practical - LAND.

FLIGHT INSTRUMENTS EMERGENCY PROCEDURES

VACUUM PUMP FAILURE (Attitude And Directional Gyros)

1. Failure indicated by left or right red failure button exposed on vacuum gage.
2. Automatic valve will select operative source.
3. Assure proper vacuum is available from operative source.

OBSTRUCTION OR ICING OF STATIC SOURCE

1. Alternate Static Source - OPEN. Alternate static source is for pilot's instruments only when dual static system is installed.
2. Excess Altitude and Airspeed - MAINTAIN to compensate for change in calibration.

NOTE

See Figures 5-2 and 5-4 for airspeed and altimeter corrections with alternate static source to OPEN.

AIR INLET OR FILTER ICING EMERGENCY PROCEDURES

1. Alternate Air Control(s) - PULL OUT.
2. Power - INCREASE as required.
3. Mixture(s) - LEAN as required.

PROPELLER SYNCHROPHASER**ENGINE INOPERATIVE PROCEDURES**

1. Propeller Synchrophaser - OFF (Optional System).

SYNCHROPHASER FAILURE

1. Propeller Synchrophaser - OFF (Optional System).
2. Propeller Synchrophaser Circuit Breaker - PULL (Optional System).

EMERGENCY EXIT WINDOW

The pilot's window (left side) can be jettisoned as follows:

1. Emergency Release Ring Plastic Cover - PULL OFF.
2. Emergency Release Ring - PULL.
3. Emergency Exit Window - PUSH OUT at bottom of window with sustained force.

SPINS

Intentional spins are not permitted in this airplane. Should a spin occur, however, the following recovery procedures should be employed:

1. Throttles - CLOSE IMMEDIATELY.
2. Ailerons - NEUTRALIZE.
3. Rudder - HOLD FULL RUDDER opposite the direction of rotation.
4. Control Wheel - FORWARD BRISKLY, 1/2 turn after applying full rudder.
5. Inboard Engine - INCREASE POWER to slow rotation. (If Necessary).

After rotation has stopped:

6. Rudder - NEUTRALIZE.
7. Inboard Engine (If used) - DECREASE POWER to equalize engines.
8. Control Wheel - PULL to recover from resultant dive. Apply smooth steady control pressure.

NOTE

The airplane has not been flight tested in spins, thus the above recommended procedure is based entirely on the best judgment of Cessna Aircraft Company.

ENGINE START/SHUTDOWN PROCEDURES (VACUUM SYSTEM CHECK)

SUPPLEMENT

TO

PILOT'S OPERATING HANDBOOK/OWNER'S MANUAL

FOR THE FOLLOWING MODELS:

ALL T303, 310/T310, 320, 335/336, 337/T337, P337, 340/340A

ALL 1976 THRU 1985 402B/402C, 404, 414/414A, 421C

SERIAL NO. 0712

REGISTRATION NO. VH-WME

This supplement must be inserted in, or attached to, the latest version of the Pilot's Operating Handbook, or Owner's Manual for the above listed airplane models.

APPROVED BY:



Michael McClary
Executive Engineer
Cessna Aircraft Company
Delegation Option Manufacturer CE-1

DATE OF APPROVAL:

06-02-99

APPROVED BY:



Wendell W. Cornell
Executive Engineer
Cessna Aircraft Company
Delegation Option Manufacturer CE-3

DATE OF APPROVAL:

11 MAY 1999

COPYRIGHT © 1999
CESSNA AIRCRAFT COMPANY
WICHITA, KANSAS, USA



Member of GAMA

SUPPLEMENT

ENGINE START/SHUTDOWN PROCEDURES (VACUUM SYSTEM CHECK)

Use the Log of Effective Pages to determine the current status of this supplement.

Pages affected by the current revision are indicated by an asterisk (*) preceding the page number.

Supplement Status	Date
Original	2 June 1999
Revision 1	3 April 2002

LOG OF EFFECTIVE PAGES

Page	Page Status	Revision Number
* 1 thru 2	Revision	1
3 thru 6	Original	0
* 7	Revision	1
8	Original	0

APPROVED BY

FAA APPROVED UNDER FAR 21 SUBPART J
The Cessna Aircraft Co.
Delegation Option Authorization DOA-100123-CE

Michael A. Kelly Executive Engineer
Brandon H. Carnil Medical Doctor

DATE OF APPROVAL

3 APRIL 2002

APPROVED BY

FAA APPROVED UNDER FAR 21 SUBPART J
The Cessna Aircraft Co.
Delegation Option Authorization DOA-230426-CE

James J. Egan Executive Engineer
John

DATE OF APPROVAL

3 APRIL 2002

SUPPLEMENT

ENGINE START/SHUTDOWN PROCEDURES (VACUUM SYSTEM CHECK)

SECTION 1 GENERAL

VACUUM SYSTEM

A vacuum system is installed to provide a source of vacuum for the vacuum instruments. The system consists of an engine-driven vacuum pump on each engine, pressure relief valve for each pump, a common vacuum manifold, vacuum air filter, suction gage and gyro instruments.

NOTE

Some earlier 300 series airplanes may have separate in-line check valves instead of a common vacuum manifold containing the check valves. These airplanes also have one common pressure relief valve in the system instead of separate relief valves for each vacuum pump.

Each vacuum pump pulls a vacuum on the common manifold, exhausting the air overboard. The maximum amount of vacuum pulled on the manifold by each vacuum pump is controlled to a preset level by each pressure relief valve. Should either of the pumps fail, a check valve is provided in each end of the manifold to isolate the inoperative vacuum pump from the system.

The exhaust air side of each attitude gyro is connected to the vacuum manifold thus providing a smooth steady vacuum for the gyros. The vacuum pressure being applied to the gyros is constantly presented on the suction gage. On later 300 series airplanes, and 400 series airplanes, this gage also provides failure indicators for the left and right vacuum pumps (refer to Figure 1). These indicators are small red buttons located in the lower portion of the suction gage which are spring-loaded to the extended (failed) position. When normal vacuum is applied in the manifold, the failure buttons are pulled flush with the gage face. Should insufficient vacuum occur on either side, the respective red button will extend. The system will automatically isolate the failed vacuum source, allowing normal operation on the remaining operative vacuum pump. Maintenance should be performed to reinstate the failed vacuum source before initiating flight into instrument meteorological conditions (IMC).

The inlet air side of the attitude gyros is connected to a common vacuum air filter which cleans the ambient cabin air before allowing it to enter the gyros.

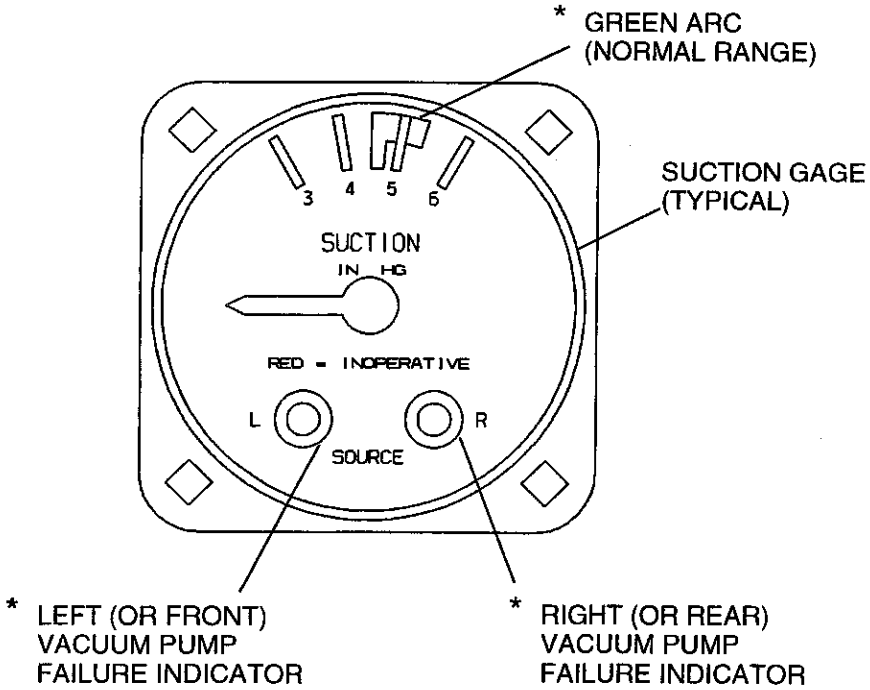

*** NOTE**

Suction gages on some earlier airplanes may not have failure indicator buttons, or a green arc on the face of the gage.

Figure 1. Typical Suction Gage with Failure Indicators

SECTION 2 LIMITATIONS

There is no change to the airplane Limitations.

SECTION 3 EMERGENCY PROCEDURES

There is no change to the airplane Emergency Procedures.

SECTION 4 NORMAL PROCEDURES

Add the following Vacuum System Check to existing Engine Start and Shutdown procedures in the Normal Procedures Abbreviated Checklist, and Amplified Normal Procedures of the Pilot's Operating Handbook or Owner's Manual.

NOTE

If the following procedures detect a defective vacuum system check valve, or failed vacuum pump, maintenance should be performed before initiating flight into instrument meteorological conditions (IMC).

(Continued Next Page)

NORMAL PROCEDURES (Continued)

NORMAL PROCEDURES ABBREVIATED CHECKLIST

STARTING ENGINES

Vacuum System - perform check per Amplified Normal Procedures.

SHUTDOWN

Vacuum System - perform check per Amplified Normal Procedures.

AMPLIFIED NORMAL PROCEDURES

AIRPLANES HAVING A SUCTION GAGE WITH FAILURE INDICATORS

STARTING ENGINES

AFTER FIRST ENGINE IS STARTED:

With throttle set at 1000 RPM or higher:

1. Suction Gage - CHECK (reading in green arc).
2. Check that the red vacuum failure button in the suction gage for that engine is flush with the gage face, prior to starting the opposite engine.
 - a. If failure button remains extended (not flush with gage face), a vacuum source failure has occurred.
 - b. If both failure buttons are flush with face of gage, a vacuum system check valve is defective.

(Continued Next Page)

AMPLIFIED NORMAL PROCEDURES (Continued)

AIRPLANES HAVING A SUCTION GAGE WITH FAILURE INDICATORS

STARTING ENGINES

AFTER SECOND ENGINE IS STARTED:

With throttle set at 1000 RPM or higher:

1. Suction Gage - CHECK (reading in green arc).
2. Check that the red vacuum failure button in the suction gage for that engine is flush with the gage face.
 - a. If failure button remains extended (not flush with gage face), a vacuum source failure has occurred.

SHUTDOWN

ENGINES:

1. Shut down engine that was started first.
 - a. The red vacuum failure button for that engine in the suction gage should extend.
 - b. If the failure button for the shutdown engine remains flush with the face of the gage, a vacuum system check valve is defective.
2. With throttle set at 1000 RPM or higher on the running engine, check that the red vacuum failure button in the suction gage for that engine is flush with the gage face.
 - a. If the red vacuum failure button for the running engine extended when the first engine was shut down, a vacuum system check valve and/or pump is defective.

(Continued Next Page)

AMPLIFIED NORMAL PROCEDURES (Continued)

AIRPLANES HAVING A SUCTION GAGE WITHOUT FAILURE INDICATORS

STARTING ENGINES

AFTER FIRST ENGINE IS STARTED:

With throttle set at 1000 RPM or higher:

1. Suction Gage - CHECK (reading in normal range).
 - a. A vacuum reading in the normal range indicates the vacuum pump for that engine is working properly.
 - b. No vacuum reading on the gage, or a reading outside the normal range, indicates a vacuum source failure or malfunction.

SHUTDOWN

ENGINES:

1. Shut down engine that was started first.

With throttle set at 1000 RPM or higher on the running engine:

2. Suction Gage - CHECK (reading in normal range).
 - a. A vacuum reading in the normal range indicates the vacuum pump for that engine is working properly.
 - b. No vacuum reading on the gage, or a reading outside the normal range, indicates a vacuum source failure or malfunction.

SECTION 5 PERFORMANCE

There is no change to the airplane performance.

SECTION 4 NORMAL PROCEDURES TABLE OF CONTENTS

	Page		Page
INTRODUCTION	4-1	Before Engine	
Preflight Inspection	4-2	Starting	4-12
NORMAL PROCEDURES		Engines Starting	4-13
ABBREVIATED CHECKLIST	4-5	Before Taxiing	4-15
Airspeeds for Safe		Taxiing	4-16
Operation	4-5	Before Takeoff	4-17
Before Engine Starting	4-5	Takeoff	4-18
Engines Starting	4-6	After Takeoff	4-19
Before Taxiing	4-6	Climb	4-20
Taxiing	4-6	Cruise	4-21
Before Takeoff	4-7	Descent	4-25
Takeoff	4-7	Before Landing	4-25
After Takeoff	4-7	Balked Landing	4-27
Climb	4-8	After Landing	4-27
Cruise	4-8	Shutdown	4-27
Descent	4-9	Stall	4-28
Before Landing	4-9	Maneuvering Flight	4-28
Balked Landing	4-9	Night Flying	4-28
After Landing	4-9	Cold Weather	
Shutdown	4-10	Operation	4-29
AMPLIFIED NORMAL		Alternate Induction	
PROCEDURES	4-11	Air	4-30
Preflight Inspection	4-11	Noise Abatement	4-31/4-32

INTRODUCTION

Section 4 of the Pilot's Operating Handbook describes the recommended procedures for normal operations. The first part of this section provides normal procedural action required in an abbreviated checklist form. Amplification of the abbreviated checklist is presented in the second part of this section.

NOTE

Refer to Section 9 of this Pilot's Operating Handbook for amended operating limitations, operating procedures, performance data and other necessary information for airplanes equipped with specific options.

PREFLIGHT INSPECTION

NOTE

- Visually check inspection plates and general airplane condition during walk-around inspection. If night flight is planned, check operation of all lights and make sure a flashlight is available.
- Refer to Section 8 for quantities, materials, and specifications of frequently used service items.

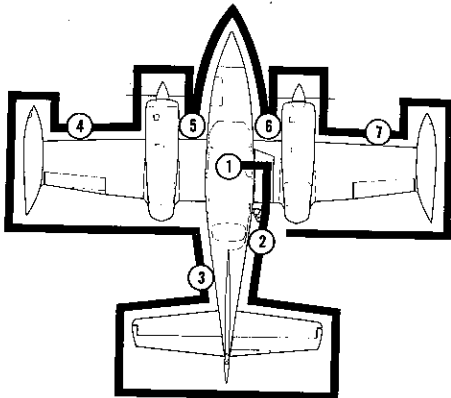

- 1
 - a. Control Lock(s) - REMOVE and stow.
 - b. Parking Brake - SET.
 - c. Alternate Static Source - CLOSED.
 - d. All Switches - OFF.
 - e. All Circuit Breakers - IN.
 - f. Landing Gear Switch - DOWN.
 - g. Left Fuel Selector - LEFT MAIN (Feel For Detent).
 - h. Right Fuel Selector - RIGHT MAIN (Feel For Detent).
 - i. Trim Tab Controls (3) - NEUTRAL.
 - j. *Oxygen - ON; Quantity, Masks and Hoses - CHECK; Oxygen - OFF.
 - k. Battery Switch - ON.
 - l. Navigation and Anti-Collision Lights - ON.
 - m. Fuel Gages - CHECK quantity and operation.
 - n. Wing Flaps - DOWN 35°.
 - o. Pitot, Stall and Vent Heat Switches - ON 20 seconds then OFF. Insure pitot tube cover(s) are removed before actuating pitot heat switch.
 - p. Windshields and Windows - CHECK for cracks and general condition.

- 2
 - a. Baggage Door - SECURE.
 - b. Air Conditioning Overboard Heat and Condensate Drain Lines - CLEAR.
 - c. Static Port(s) - CLEAR.
 - d. *Deice Boots - CHECK condition and security.
 - e. Control Surface Lock(s) - REMOVE, if installed.
 - f. Elevator and Tab - CHECK condition, freedom of movement, and tab position.
 - g. Tie Down - REMOVE.
 - h. Rudder and Tab - CHECK condition, freedom of movement and tab position.
 - i. *Deice Boots - CHECK condition and security.

- 3
 - a. Static Port(s) - CLEAR.
 - b. Wing Locker Baggage Door - SECURE.
 - c. Battery Compartment Cover - SECURE.
 - d. Wing Flap - CHECK security and attachment.
 - e. Bottom Outboard Wing - CHECK for fuel stains.
 - f. Control Surface Lock - REMOVE, if installed.
 - g. Aileron and Tab - CHECK condition, freedom of movement and tab position.
 - h. Tip Tank Transfer Pump - LISTEN for operation.
 - i. Main Tank Fuel Vent - CLEAR.
 - j. Navigation and Anti-Collision Lights - CHECK operation.
 - k. Landing Light Filament - CHECK condition.
 - l. Main Tank Fuel Sump - DRAIN.
 - m. Fuel Vent and Sniffle Valve - CLEAR.
 - n. Main Tank Fuel Quantity - CHECK; Cap - SECURE.
 - o. *Deice Boot - CHECK condition and security.
 - p. Stall Warning Vane - CHECK freedom of movement and audible warning.
 - q. Wing Tie Down - REMOVE.

Figure 4-1 (Sheet 1 of 2)

PREFLIGHT INSPECTION

- ④ a. Auxiliary Tank Fuel Quantity - CHECK; Cap - SECURE.
b. *Wing Locker Tank Fuel Vent - CLEAR.
c. *Auxiliary Tank and Wing Locker Transfer Line Fuel Sump - DRAIN.
d. Fuel Strainer - DRAIN.
e. *Wing Locker Tank Fuel Quantity - CHECK; Cap - SECURE.
f. Oil Level - CHECK, minimum 9 quarts.
g. Engine Compartment General Condition - CHECK for fuel, oil and exhaust leaks or stains.
h. Propeller and Spinner - EXAMINE for nicks, security and oil leaks.
i. Leading Edge Air Intake - CLEAR.
j. Main Gear Strut, Doors, Tire and Wheel Well - CHECK.
k. *Wing Locker Tank Fuel Sump - DRAIN.
- ⑤ a. Nose Baggage Door - SECURE.
b. Nose Gear, Strut, Doors, Tire and Wheel Well - CHECK.
c. Lower Fuselage, Nose and Center Section - CHECK for leaks or stains and antenna security.
d. Pitot Cover(s) - REMOVE; Pitot Tube(s) - CLEAR and WARM.
e. Tie Down - REMOVE.
f. Heater Inlet - CLEAR.
- ⑥ a. Leading Edge Air Intake - CLEAR.
b. Crossfeed Lines - DRAIN.
c. *Wing Locker Tank Fuel Sump - DRAIN.
d. Main Gear, Strut, Doors, Tire and Wheel Well - CHECK.
e. *Wing Locker Tank Fuel Quantity - CHECK; Cap - SECURE.
f. Oil Level - CHECK, minimum 9 quarts.
g. Engine Compartment General Condition - CHECK for fuel, oil and exhaust leaks or stains.
h. Propeller and Spinner - EXAMINE for nicks, security and oil leaks.
i. *Wing Locker Tank Fuel Vent - CLEAR.
j. *Auxiliary Tank and Wing Locker Transfer Line - DRAIN.
k. Fuel Strainer - DRAIN.
l. *Auxiliary Tank Fuel Quantity - CHECK; Cap - SECURE.
- ⑦ a. Wing Tie Down - REMOVE.
b. *Deice Boot - CHECK condition and security.
c. Main Tank Fuel Quantity - CHECK; Cap - SECURE.
d. Navigation and Anti-Collision Lights - CHECK operation.
e. Fuel Vent and Sniffle Valve - CLEAR.
f. Main Tank Fuel Sump - DRAIN.
g. Tip Tank Transfer Pump - LISTEN for operation.
h. Main Tank Fuel Vent - CLEAR.
i. *Landing Light Filament - CHECK condition.
j. Control Surface Lock - REMOVE, if installed.
k. Aileron - CHECK condition and freedom of movement.
l. Bottom Outboard Wing - CHECK for fuel stains.
m. Wing Flap - CHECK security and attachment.
n. Wing Locker Baggage Door - SECURE.
o. Battery Switch - OFF.
p. Navigation and Anti-Collision Lights - OFF.

*Denotes items to be checked if the applicable optional equipment is installed on your airplane.

Figure 4-1 (Sheet 2 of 2)

NORMAL PROCEDURES ABBREVIATED CHECKLIST

AIRSPEEDS FOR SAFE OPERATION

Conditions:	
1. Takeoff Weight 5500 Pounds	3. Sea Level, Standard Day
2. Landing Weight 5400 Pounds	
(1) Takeoff and Climb to 50 Feet (0° Flaps)	92 KIAS
(2) All Engines Best Angle-of-Climb Speed	85 KIAS
(3) All Engines Best Rate-of-Climb Speed	107 KIAS
(4) All Engines Landing Approach Speed (35° Flaps)	93 KIAS
(5) Maneuvering Speed	148 KIAS
(6) Structural Cruise Speed	181 KIAS
(7) Never Exceed Speed	223 KIAS
(8) Speed for Transition to Balked Landing Conditions	85 KIAS
(9) Maximum Demonstrated Crosswind Velocity	19 KNOTS

Figure 4-2

BEFORE ENGINE STARTING

1. Preflight Inspection - COMPLETE.
2. Control Lock(s) - REMOVE.
3. Seat, Seat Belts and Shoulder Harness - ADJUST and SECURE.
4. Brakes - TEST and SET.
5. Landing Gear Switch - DOWN.
6. Emergency Alternator Field Switch - OFF.
7. Emergency Avionics Power Switch - OFF.
8. Circuit Breakers - IN.
9. All Switches - OFF.
10. Avionics Master Switch - OFF.
11. Auxiliary Fuel Pump Switches - OFF.
12. Battery and Alternators - ON.
13. Lighting Rheostats - AS REQUIRED.
14. Altimeter and Clock - SET.
15. All Warning Lights - PRESS-TO-TEST.
16. Landing Gear Position Indicator Lights - Check green lights ON.
17. Cabin Air Controls - AS REQUIRED.
18. Fuel Quantity - CHECK.
19. Throttles - OPEN ONE INCH.
20. Propellers - FULL FORWARD.
21. Mixtures - FULL RICH.
22. Cowl Flaps - LOCKED FULL OPEN.
23. Fuel Selectors - MAIN TANKS (Feel For Detent).
24. Alternate Air Controls - IN.
25. Anti-Collision Lights - ON.

ENGINES STARTING (Left Engine First Without External Power)

1. Propeller - CLEAR.
2. Magneto Switches - ON.
3. Engine - START.
 - a. Starter Button - PRESS.
 - b. Primer Switch - Left Engine - LEFT.
Right Engine - RIGHT.
4. Auxiliary Fuel Pump - LOW to purge vapor from fuel system.
5. Throttle - 800 to 1000 RPM.
6. Oil Pressure - CHECK.
7. Right Engine - START. Repeat steps 1 through 6.
8. Alternators - CHECK.

ENGINES STARTING (Left Engine First With External Power)

1. Battery and Alternators - OFF.
2. External Power Source - ATTACH.
3. Propeller - CLEAR.
4. Magneto Switches - ON.
5. Engine - START.
 - a. Starter Button - PRESS.
 - b. Primer Switch - Left Engine - LEFT.
Right Engine - RIGHT.
6. Auxiliary Fuel Pump - LOW to purge vapor from fuel system.
7. Throttle - 800 to 1000 RPM.
8. Oil Pressure - CHECK.
9. Right Engine - START. Repeat steps 3 through 8.
10. External Power Source - REMOVE.
11. Battery and Alternators - ON.
12. Alternators - CHECK.

BEFORE TAXIING

1. Wing Flaps - UP.
2. Avionics Master Switch - ON.
3. Avionics - SET.
4. Lights - AS REQUIRED.
5. Cabin Temperature - AS REQUIRED.
 - a. If heating and defrosting is required:
 - (1) Cabin Air Knobs - OPEN.
 - (2) Defrost Knob - AS REQUIRED.
 - (3) Temperature Control Knob - OPEN.
 - (4) Cabin Heat Switch - HEAT.
 - (5) Heat Registers - AS REQUIRED.
 - b. If ventilation is required:
 - (1) Cabin Air Knobs - OPEN.
 - (2) Cabin Heat Switch - FAN.
 - (3) Heat Registers - AS REQUIRED.
6. Brakes - RELEASE.

TAXIING

1. Throttles - AS REQUIRED.
2. Brakes - CHECK.
3. Rate Gyros - CHECK.

BEFORE TAKEOFF

1. Brakes - SET.
2. Engine Runup:
 - a. Throttles - 1700 RPM.
 - b. Alternators - CHECK.
 - c. Vacuum System - CHECK 4.75 to 5.25 inches Hg.
 - d. Magnetos - CHECK 150 RPM maximum drop with a maximum differential of 50 RPM.
 - e. Propellers - CHECK feathering to 1200 RPM; return to high RPM.
 - f. Engine Instruments - CHECK green arc.
 - g. Throttles - 1000 RPM.
3. Flight Controls - CHECK, free and correct.
4. Trim Tabs - SET.
5. Cowl Flaps - LOCKED FULL OPEN.
6. Alternate Air Controls - IN.
7. Fuel Selectors - RECHECK - Left Engine - LEFT MAIN (Feel For Detent).
Right Engine - RIGHT MAIN (Feel For Detent).
8. Wing Flaps - UP.
9. Cabin Door and Window - CLOSED and LOCKED.
10. Fuel Quantity - CHECK.
11. Flight Instruments and Avionics - SET.
12. Lights - AS REQUIRED.
13. Auxiliary Fuel Pumps - ON.
14. Brakes - RELEASE.

TAKEOFF**NORMAL TAKEOFF**

1. Power - FULL THROTTLE and 2700 RPM.
2. Mixtures - LEAN for field elevation (See Figure 5-27).
3. Air Minimum Control Speed - 80 KIAS.
4. Elevator Control - Raise nosewheel at 83 KIAS.
5. Lift-Off - 92 KIAS.

MAXIMUM PERFORMANCE TAKEOFF

1. Wing Flaps - DOWN 15⁰.
2. Brakes - SET.
3. Power - FULL THROTTLE.
4. Mixtures - LEAN for field elevation (See Figure 5-27).
5. Brakes - RELEASE.
6. Power - CHECK 2700 RPM.
7. Elevator Control - Raise nosewheel at 70 KIAS.
8. Air Minimum Control Speed - 80 KIAS.
9. Lift-Off - 82 KIAS. Hold speed until all obstacles are cleared.

AFTER TAKEOFF

1. Brakes - APPLY momentarily.
2. Landing Gear - RETRACT. Check red light OFF.
3. Wing Flaps - UP.
4. Climb Speed - 107 KIAS (All Engines Best Rate-Of-Climb Speed).
5. Auxiliary Fuel Pumps - OFF.

CLIMB

CRUISE CLIMB

1. Power - 2500 RPM and 24.5 inches Hg.
2. Airspeed - 115 to 130 KIAS.
3. Mixtures - ADJUST to climb fuel flow (See Figure 5-27).
4. Cowl Flaps - OPEN or as required.
5. Auxiliary Fuel Pumps - ON above 12,000 feet altitude to minimize vapor formation.
6. Propellers - SYNCHRONIZE manually.
7. Quadrant Friction Lock - TIGHTEN securely (With Synchrophaser Installed).
8. Propeller Synchrophaser - SYNC (Optional System).

MAXIMUM CLIMB

1. Power - 2700 RPM and FULL THROTTLE.
2. Airspeed - 107 KIAS at sea level; 99 KIAS at 10,000 feet.
3. Mixtures - ADJUST for altitude and power (See Figure 5-27).
4. Cowl Flaps - OPEN or as required.
5. Auxiliary Fuel Pumps - ON above 12,000 feet altitude to minimize vapor formation.

CRUISE

1. Cruise Power - 2100 to 2500 RPM and 15.0 to 24.5 inches Hg.
2. Mixtures - LEAN. Recheck if power, altitude or OAT changes.
3. Cowl Flaps - OPEN or as required.
4. Propellers - SYNCHRONIZE manually.
5. Quadrant Friction Lock - TIGHTEN securely (With Synchrophaser Installed).
6. Propeller Synchrophaser - SYNC (Optional System).
7. In Smooth Air After Propellers Synchronize - PHASE; Phasing Knob - ADJUST for desired phasing position (Optional System).
8. Auxiliary Fuel Pumps - LOW when switching tanks.
9. Fuel Selectors - Left Engine - LEFT MAIN (Feel For Detent).
Right Engine - RIGHT MAIN (Feel For Detent).
 - a. If optional 40-gallon auxiliary tanks are installed, fuel selectors - MAIN TANKS for 60 minutes.
 - b. If optional 63-gallon auxiliary tanks are installed, fuel selectors - MAIN TANKS for 90 minutes.
 - c. Usable auxiliary fuel quantity is based on level flight.
 - d. If wing locker tanks are installed, fuel selectors - MAIN TANKS or, after wing locker tanks are transferred and main tank quantity is less than 180 pounds each - AUXILIARY TANKS.
 - e. If wing locker tanks are installed, crossfeed - SELECT as required to maintain fuel balance after wing locker tank fuel transfer.
10. If oxygen use is desired, proceed as follows:
 - a. Mask - Connect mask and hose assembly and put mask on.
 - b. Hose Coupling - Plug into oxygen outlet in the overhead console.
 - c. Oxygen Flow Indicator - Check Flow. (Indicator Toward Mask Indicates Proper Flow).
 - d. Disconnect hose coupling when not in use.
11. Trim Tabs - ADJUST.

DESCENT

1. Power - AS REQUIRED to maintain engine temperatures in the green.
2. Cowl Flaps - AS REQUIRED.
3. Propeller Synchrophaser - AS REQUIRED (Optional System).
4. Mixtures - ADJUST for smooth operation with gradual enrichment as altitude is lost.
5. Altimeter - SET.

BEFORE LANDING

1. Fuel Selectors - Left Engine - LEFT MAIN (Feel For Detent).
Right Engine - RIGHT MAIN (Feel For Detent).
2. Auxiliary Fuel Pumps - ON.
3. Alternate Air Controls - CHECK IN.
4. Mixtures - AS REQUIRED for flight altitude.
5. Propeller Synchrophaser - OFF (Optional System).
6. Propellers - FULL FORWARD.
7. Wing Flaps - DOWN 15° below 158 KIAS.
8. Landing Gear - DOWN below 138 KIAS.
9. Landing Gear Position Indicator Lights - Check down lights ON;
Unlocked Light - OFF.
10. Wing Flaps - DOWN 35° below 138 KIAS.
11. Minimum Multi-Engine Approach Speed - 93 KIAS.
12. Air Minimum Control Speed - 80 KIAS.

BALKED LANDING

1. Increase engine speed to 2700 RPM and apply full throttle if necessary.
2. Mixtures - AS REQUIRED.
3. Balked Landing Transition Speed - 85 KIAS.
4. Landing Gear - RETRACT during IFR go-around or simulated IFR go-around.
5. Reduce wing flap setting to 15°.
6. Trim airplane for climb.
7. Cowl Flaps - OPEN.
8. Retract wing flaps as soon as all obstacles are cleared and a safe altitude and airspeed are obtained.

AFTER LANDING

1. Auxiliary Fuel Pumps - LOW during landing roll.
2. Cowl Flaps - OPEN.
3. Wing Flaps - UP.

SHUTDOWN

1. Auxiliary Fuel Pumps - OFF.
2. Avionics Master Switch - OFF.
3. All Switches Except Battery, Alternator and Magneto Switches - OFF.
4. Throttles - IDLE.
5. Mixtures - IDLE CUT-OFF.
6. Magneto Switches - OFF, after engines stop.
7. Battery and Alternators - OFF.
8. Parking Brake - SET.
9. Control Lock(s) - INSTALL.
10. Fuel Selectors - OFF if a long period of inactivity is anticipated
(Feel For Detent).
11. Cabin Door - CLOSE.

AMPLIFIED NORMAL PROCEDURES

PREFLIGHT INSPECTION

The Preflight Inspection, described in Figure 4-1, is recommended for the first flight of the day. Inspection procedures for subsequent flights are normally limited to brief checks of the tail surface hinges, fuel and oil quantity and security of fuel and oil filler caps. If the airplane has been in extended storage, has had recent major maintenance or has been operated from marginal airports, a more extensive exterior inspection is recommended.

After major maintenance has been performed, the flight and trim tab controls should be double-checked for free and correct movement and security. The security of all inspection plates on the airplane should be checked following periodic inspections. Since avionics and heater maintenance requires the mechanic to work in the nose compartment, the nose cap is removed and the nose compartment door is opened for access to equipment. Therefore, it is important after such maintenance to double-check the security of the nose cap and this door. If the airplane has been waxed or polished, check the external static pressure source holes for stoppage.

If the airplane has been exposed to much ground handling in a crowded hangar, it should be checked for dents and scratches on wings, main tanks, fuselage and tail surfaces, as well as damage to navigation and landing lights, deice boots and avionics antenna. Outside storage for long periods may result in water and obstructions in airspeed system lines, condensation in fuel tanks, and dust and dirt on the intake air filters and engine cooling fins. Outside storage in windy or gusty areas, or adjacent to taxiing airplanes, calls for special attention to control surface stops, hinges and brackets to detect presence of wind damage.

If the airplane has been operated from muddy fields or in snow or slush, check the main gear and nose gear wheel wells for obstructions and cleanliness. Operation from a gravel or cinder field will require extra attention to propeller tips and abrasion on leading edges of the horizontal tail. Stone damage to the outer six inches of the propeller tips can seriously reduce the fatigue life of the blades.

Airplanes that are operated from rough fields, especially at high altitudes, are subjected to abnormal landing gear abuse. Check frequently all components of the landing gear retracting mechanisms, shock struts, tires and brakes. Undue landing and taxi loads will be subjected on the airplane structure when the shock struts are insufficiently extended. A completely collapsed (zero extension) shock strut could cause a malfunction in the landing gear retraction system.

To prevent loss of fuel in flight, make sure main and auxiliary fuel tank filler caps are tightly sealed. The main fuel tank vents on the lower surface of the main tanks should also be inspected for obstructions, ice or water, especially after operation in cold, wet weather.

The interior inspection will vary according to the planned flight and the optional equipment installed. Prior to high-altitude flights, it is important to check the condition and quantity of oxygen face masks and hose assemblies. The oxygen supply system should be functionally checked to insure that it is in working order. The oxygen pressure gage should indicate between 300 and 1800 or 1850 PSI depending upon the anticipated requirements.

Satisfactory operation of the pitot tube(s), stall warning transmitter and optional wing locker fuel tank vent heating elements is determined by observing a discharge on the voltammeter when the pitot heat switch is turned ON. The effectiveness of these heating elements may be verified by cautiously feeling the heat of these devices while the switch is ON.

Flights at night and in cold weather involve a careful check of other specific areas which will be discussed later in this section.

NOTE

The pilot is responsible to assure that the airplane is loaded within the weight and C.G. limits.

BEFORE ENGINE STARTING

1. Preflight Inspection - COMPLETE.
2. Control Lock(s) - REMOVE.
3. Seat, Seat Belts and Shoulder Harness - ADJUST and SECURE.
4. Brakes - TEST and SET.
5. Landing Gear Switch - DOWN.
6. Emergency Alternator Field Switch - OFF.
7. Emergency Avionics Power Switch - OFF.
8. Circuit Breakers - IN.
9. All Switches - OFF.
10. Avionics Master Switch - OFF.
11. Auxiliary Fuel Pump Switches - OFF.
12. Battery and Alternators - ON.

NOTE

When using an external power source, do not turn on the battery or alternator switches until the external power source is disconnected to avoid damage to the alternators and/or a weak battery draining off part of the current being supplied by the external source.

13. Lighting Rheostats - AS REQUIRED.
14. Altimeter and Clock - SET.
15. All Warning Lights - PRESS-TO-TEST.
16. Landing Gear Position Indicator Lights - Check green lights ON.
17. Cabin Air Controls - AS REQUIRED.
18. Fuel Quantity - CHECK.
19. Throttles - OPEN ONE INCH.
20. Propellers - FULL FORWARD.
21. Mixtures - FULL RICH.
22. Cowl Flaps - LOCKED FULL OPEN.
23. Fuel Selectors - Left Engine - LEFT MAIN (Feel For Detent).
Right Engine - RIGHT MAIN (Feel For Detent).
24. Alternate Air Controls - IN.
25. Anti-Collision Lights - ON.

ENGINES STARTING (Left Engine First Without External Power)

1. Propeller - CLEAR.
2. Magneto Switches - ON.
3. Engine - START.
 - a. Starter Button - PRESS.
 - b. Primer Switch - Left Engine - LEFT.
Right Engine - RIGHT.

CAUTION

- If the primer is activated for excessive periods of time with the engine inoperative on the ground or during flight, damage may be incurred to the engine and/or airplane due to fuel accumulation in the induction system. Similar conditions may develop when the engine is shutdown with the auxiliary fuel pump ON.
- During very hot weather, caution should be exercised to prevent overpriming the engine.
- Should fuel priming or auxiliary fuel pump operation periods in excess of 60 seconds occur, the engine manifold must be purged by one of the following procedures:
 - a. With auxiliary fuel pump OFF, allow manifold to drain at least 5 minutes or until fuel ceases to flow out of the drain under the nacelle.
 - b. If circumstances do not allow natural draining periods recommended above, with the auxiliary fuel pump OFF, magnetos OFF, mixture IDLE CUT-OFF and throttle FULL OPEN, turn engine with starter or by hand a minimum of 15 revolutions.

4. Auxiliary Fuel Pump - LOW to purge vapor from fuel system.
5. Throttle - 800 to 1000 RPM.
6. Oil Pressure - 10 PSI minimum in 30 seconds in normal weather, or 60 seconds in cold weather. If no indication appears, shutdown engine and investigate.
7. Right Engine - START. Repeat steps 1 through 6.
8. Alternators - CHECK.

ENGINES STARTING (Left Engine First With External Power)

1. Battery Switch - ON.
2. Alternator Switches - OFF.
3. External Power Source - ATTACH.

NOTE

For complete external power source operation, refer to Section 7.

4. Propeller - CLEAR.

5. Magneto Switches - ON.
6. Engine - START.
 - a. Starter Button - PRESS.
 - b. Primer Switch - Left Engine - LEFT.
Right Engine - RIGHT.

CAUTION

- If the primer is activated for excessive periods of time with the engine inoperative on the ground or during flight, damage may be incurred to the engine and/or airplane due to fuel accumulation in the induction system. Similar conditions may develop when the engine is shutdown with the auxiliary fuel pump ON.
- During very hot weather, caution should be exercised to prevent overpriming the engine.
- Should fuel priming or auxiliary fuel pump operation periods in excess of 60 seconds occur, the engine manifold must be purged by one of the following procedures:
 - a. With auxiliary fuel pump OFF, allow manifold to drain at least 5 minutes or until fuel ceases to flow out of the drain under the nacelle.
 - b. If circumstances do not allow natural draining periods recommended above, with the auxiliary fuel pump OFF, magnetos OFF, mixture IDLE CUT-OFF and throttle FULL OPEN, turn engine with starter or by hand a minimum of 15 revolutions.

7. Auxiliary Fuel Pump - LOW to purge vapor from fuel system.
8. Throttle - 800 to 1000 RPM.
9. Oil Pressure - 10 PSI minimum in 30 seconds in normal weather, or 60 seconds in cold weather. If no indication appears, shutdown engine and investigate.
10. Right Engine - START. Repeat steps 4 through 9.
11. External Power Source - REMOVE.
12. Alternator Switches - ON.
13. Alternators - CHECK.

The left engine is normally started first because the cable from the battery to this engine is much shorter permitting more electrical power to be delivered to the starter. If battery is low, the left engine should start more readily.

When using an external power source, it is recommended to start the airplane with the alternator switches OFF.

NOTE

Release starter button as soon as engine fires or engine will not accelerate and flooding can result.

The continuous flow fuel injection system will start spraying fuel in the engine intake ports as soon as the primer switch is actuated and the throttle and mixture controls are opened. If the auxiliary pump is turned on accidentally while the engine is stopped with the throttle open and the mixture rich, liquid fuel will collect temporarily in the cylinder intake ports. The quantity of fuel deposited will depend upon the amount of throttle opening and the length of time the pump has been operating. If this happens, it is advisable to wait a few minutes until the fuel drains away, then turn the propeller through 15 complete revolutions. This is done to prevent the possibility of engine damage due to hydrostatic lock before starting the engine. To avoid flooding, begin cranking the engine prior to priming the engine.

CAUTION

Caution should be exercised to prevent overpriming the engine in hot weather.

Engine mis-starts, characterized by weak intermittent explosions followed by black puffs of smoke from the exhaust, are the result of flooding or overpriming. This situation is more apt to develop in hot weather, or when the engines are hot. If it occurs, repeat the starting procedure with the throttle approximately 1/2 open, the mixture in IDLE CUT-OFF and the primer switch OFF. As the engine fires, move the mixture control to FULL RICH and close the throttle to idle.

If an engine is underprimed, as may occur in cold weather with a cold engine, repeat the starting procedure while holding the primer switch ON for 5 to 10 seconds until the engine fires.

If cranking longer than 30 seconds is required, allow starter-motor to cool five minutes before cranking again since excessive heat may damage the armature windings.

After the engines are started, the auxiliary fuel pumps should be switched to LOW to provide for improved purging and vapor clearing in the fuel system.

BEFORE TAXIING

1. Wing Flaps - UP.
2. Avionics Master Switch - ON.
3. Avionics - SET.
4. Lights - AS REQUIRED.
5. Cabin Temperature - AS REQUIRED.
 - a. If heating and defrosting is required:
 - (1) Cabin Air Knobs - OPEN.
 - (2) Defrost Knob - AS REQUIRED.
 - (3) Temperature Control Knob - OPEN.
 - (4) Cabin Heat Switch - HEAT.
 - (5) Heat Registers - AS REQUIRED.

- b. If ventilation is required:
 - (1) Cabin Air Knobs - OPEN.
 - (2) Cabin Heat Switch - FAN.
 - (3) Heat Registers - AS REQUIRED.
6. Brakes - RELEASE. Pushing in the parking brake knob releases the trapped brake fluid, allowing the brakes to be released.

TAXIING

1. Throttles - AS REQUIRED.
2. Brakes - CHECK.
3. Rate Gyros - CHECK.

A steerable nosewheel, interconnected with the rudder system, provides positive control up to 18° left or right, and free turning from 18° to 55° for sharp turns during taxiing. Normal steering may be aided through use of differential power and differential braking on the main wheels. These aids are listed in the preferred order of use. Do not use excessive brake on the inboard side to effect a turning radius as decreased tire life will result.

NOTE

If the airplane is parked with the nosewheel casted in either direction, initial taxiing should be done with caution. To straighten the nosewheel, use full opposite rudder and differential power instead of differential braking. After a few feet of forward travel, the nosewheel will steer normally.

When taxiing near buildings or other stationary objects, observe the minimum turning radius limits as stated in Figure 7-10. No abnormal precautions are required when taxiing in conditions of high winds.

At some time early in the taxi run, the brakes should be checked for any unusual reaction, such as uneven braking. The operation of the turn-and-bank indicator and directional gyro should also be checked during taxiing. When turning right, the turn-and-bank needle should deflect right while the ball goes left and directional gyro heading increases in numerical value. In a left turn the converse is true. At this time the artificial horizon should be up to speed and indicating a level attitude.

Most of the engine warm-up should be done during taxiing, with just enough power to keep the airplane moving. Engine speed should not exceed 1000 RPM while the oil is cold.

Do not operate engines at high RPM when taxiing over gravel or loose material that may cause damage to the propeller blades.

BEFORE TAKEOFF

1. Brakes - SET.
2. Engine Runup:
 - a. Throttles - 1700 RPM.
 - b. Alternators - CHECK.
 - c. Vacuum System - CHECK 4.75 to 5.25 inches Hg.
 - d. Magnetos - CHECK 150 RPM maximum drop with a maximum differential of 50 RPM.
 - e. Propellers - CHECK feathering to 1200 RPM; return to high RPM (Full Forward Position).
 - f. Engine Instruments - CHECK green arc.
 - g. Throttles - 1000 RPM.

NOTE

It is important that the engine oil temperature be within the normal operating range prior to applying takeoff power.

3. Flight Controls - CHECK, free and correct.
4. Trim Tabs - SET elevator, aileron and rudder tabs in the TAKEOFF range.
5. Cowl Flaps - LOCKED FULL OPEN.
6. Alternate Air Controls - IN.
7. Fuel Selectors - RECHECK - Left Engine - LEFT MAIN (Feel For Detent).
Right Engine - RIGHT MAIN (Feel For Detent).
8. Wing Flaps - UP.
9. Cabin Door and Window - CLOSE and LOCKED.
10. Fuel Quantity - CHECK.
11. Flight Instruments and Avionics - SET.
12. Lights - AS REQUIRED.
13. Auxiliary Fuel Pumps - ON.
14. Brakes - RELEASE. Push in parking brake control.

Full throttle checks on the ground are not recommended unless there is good reason to suspect that the engines are not operating properly. Do not runup the engines over loose gravel or cinders because of possible stone damage or abrasion to the propeller tips.

If the ignition system produces an engine speed drop in excess of 150 RPM, or if the drop in RPM between the left and right magneto differs by more than 50 RPM, continue warm-up a minute or two longer before rechecking the system. If there is doubt concerning operation of the ignition system, checks at higher engine speed will usually confirm if a deficiency exists. In general, a drop in excess of 150 RPM is not considered acceptable.

A careful check should be made of the vacuum system. The minimum and maximum allowable suction are 4.75 and 5.25 inches Hg., respectively, on the instrument. Good alternator condition is also important for instrument flight since satisfactory operation of all avionics equipment and electrical instruments is essential. The alternators are checked during engine runup (1700 RPM) by positioning the selector switch in the L ALT and R ALT position and observing the charging rate on the voltmeter.

A simple last minute recheck of important items should include a quick glance to see if all switches are ON, the mixture and propeller controls are forward, all flight controls have free and correct movement and the fuel selectors are properly positioned.

A mental review of all single-engine speeds, procedures and field length requirements should be made prior to takeoff.

TAKEOFF

NORMAL TAKEOFF

1. Power - FULL THROTTLE and 2700 RPM.

NOTE

Apply full throttle smoothly to avoid propeller surging.

2. Mixtures - LEAN for field elevation (See Figure 5-27).
3. Air Minimum Control Speed - 80 KIAS.
4. Elevator Control - Raise nosewheel at 83 KIAS.
5. Lift-Off - 92 KIAS.

MAXIMUM PERFORMANCE TAKEOFF

1. Wing Flaps - DOWN 15°.
2. Brakes - SET.
3. Power - FULL THROTTLE.

NOTE

Apply full throttle smoothly to avoid propeller surging.

4. Mixtures - LEAN for field elevation (See Figure 5-27).
5. Brakes - RELEASE.
6. Power - CHECK 2700 RPM.

NOTE

Leaning during the takeoff roll at low altitudes is normally not necessary for smooth engine operation; however, fuel flows should be adjusted to match field elevation to obtain maximum airplane performance.

7. Elevator Control - Raise nosewheel at 70 KIAS.
8. Air Minimum Control Speed - 80 KIAS.
9. Lift-Off - 82 KIAS. Hold speed until all obstacles are cleared.

Since the use of full throttle is not recommended in the static runup, closely observe full-power engine operation early in the takeoff run. Signs of rough engine operation, unequal power between engines, or sluggish engine acceleration are good cause for discontinuing the takeoff. If this occurs, make a thorough full throttle static runup before another takeoff is attempted.

For maximum performance takeoff, the engines should be run up to full power before brake release. For maximum engine power, the mixture should be adjusted during the initial acceleration to the recommended fuel flow for the field elevation. The engine acceleration is increased significantly with fuel leaning above 3000 feet. This procedure always should be employed for field elevations greater than 5000 feet above sea level. Refer to the Pilot's Checklist or Figure 5-27 for recommended fuel flows.

Full throttle operation is recommended on takeoff since it is important that a speed well above air minimum control speed (80 KIAS) be obtained as rapidly as possible. It is desirable to accelerate the airplane to 92 KIAS (recommended safe single-engine speed) before lift-off for additional safety in case of an engine failure. This safety may have to be compromised slightly where short and rough fields prohibit such high speed before takeoff.

For crosswind takeoffs, additional power may be carried on the upwind engine until the rudder becomes effective. The airplane is accelerated to a slightly higher than normal takeoff speed, and then is pulled off abruptly to prevent possible settling back to the runway while drifting. When clear of the ground, a coordinated turn is made into the wind to correct for drift.

A takeoff with one main tank full and the opposite tank empty creates a lateral unbalance. This is not recommended since gusty air or premature lift-off could create a serious control problem.

After takeoff, it is important to maintain the recommended safe single-engine climb speed (92 KIAS) to 50 feet. As the airplane accelerates still further to all engines best rate-of-climb speed (107 KIAS), it is good practice to climb rapidly to an altitude at which the airplane is capable of circling the field on one engine.

AFTER TAKEOFF

1. Brakes - APPLY momentarily.
2. Landing Gear - RETRACT. Check red light OFF.
3. Wing Flaps - UP after obstacles are cleared if maximum performance takeoff.
4. Climb Speed - 107 KIAS (All Engines Best Rate-Of-Climb Speed).
5. Auxiliary Fuel Pumps - OFF.

To establish climb configuration, retract the landing gear, adjust power for climb, turn off auxiliary fuel pumps and adjust the mixtures for the selected power setting.

Before retracting the landing gear, apply the brakes momentarily to stop the rotation of the main wheels. Centrifugal force caused by the rapidly rotating wheels expands the diameter of the tires, and if ice or mud has accumulated in the wheel wells, the rotating wheels may rub as they enter.

On long runways, the landing gear should be retracted at the point over the runway where a wheels-down forced landing on that runway would become impractical. However, on short runways it may be preferable to retract the landing gear after the airplane is safely airborne.

Power reduction will vary according to the requirements of the traffic pattern or surrounding terrain, weight, field elevation, temperature, environmental considerations and engine condition. However, a normal after takeoff power setting is 2500 RPM and 24.5 inches Hg. manifold pressure.

CLIMB

CRUISE CLIMB

1. Power - 2500 RPM and 24.5 inches Hg.
2. Airspeed - 115 to 130 KIAS.
3. Mixtures - ADJUST to climb fuel flow (See Figure 5-27).
4. Cowl Flaps - OPEN as required.
5. Auxiliary Fuel Pumps - ON above 12,000 feet altitude to minimize vapor formation.

NOTE

During very hot weather, if there is an indication of vapor in the fuel system (fluctuating fuel flow) or anytime when climbing above 12,000 feet, turn the auxiliary fuel pumps ON until cruising altitude has been obtained and the system is purged (usually 5 to 15 minutes after establishing cruising flight).

6. Propellers - SYNCHRONIZE manually.
7. Quadrant Friction Lock - TIGHTEN securely (With Synchrophaser Installed).
8. Propeller Synchrophaser - SYNC (Optional System).

MAXIMUM CLIMB

1. Power - FULL THROTTLE and 2700 RPM.
2. Airspeed - 107 KIAS at sea level; 99 KIAS at 10,000 feet.
3. Mixtures - ADJUST for altitude and power (See Figure 5-27).
4. Cowl Flaps - OPEN as required.
5. Auxiliary Fuel Pumps - ON above 12,000 feet altitude to minimize vapor formation.

NOTE

During very hot weather, if there is an indication of vapor in the fuel system (fluctuating fuel flow) or anytime when climbing above 12,000 feet, turn the auxiliary fuel pumps ON until cruising altitude has been obtained and the system is purged (usually 5 to 15 minutes after establishing cruising flight). It is recommended that the mixture remain at the climb mixture setting for approximately 5 minutes after establishing cruising flight before leaning is initiated.

To save time and fuel for the overall trip, it is recommended that the normal cruising climb be conducted at 115 to 130 KIAS, using approximately 75% power (2500 RPM and 24.5 inches Hg. manifold pressure).

Cruising climbs and maximum climbs should be conducted at the recommended fuel flows shown in the Pilot's Checklist and Figure 5-27.

If it is necessary to climb rapidly to clear mountains or reach favorable winds at high altitudes, the best rate-of-climb speed should be used with maximum power. This speed varies from 107 KIAS at sea level to 99 KIAS at 10,000 feet. During maximum performance climbs, the mixture should be leaned to the recommended fuel flow. It is recommended that the auxiliary fuel pumps be on at altitudes above 12,000 feet for the duration of the climb and approximately 5 to 15 minutes after establishing cruising flight. It is also recommended that the mixture remain at the climb mixture setting for approximately 5 minutes after establishing cruising flight before leaning is initiated. These procedures will eliminate fuel vaporization problems likely to occur from rapid altitude changes.

If an obstruction ahead requires a steep climb angle, the airplane should be flown at the all engines best angle-of-climb speed with flaps up and maximum power. This speed varies from 85 KIAS at sea level to 89 KIAS at 15,000 feet.

During cruise climbs, positioning the propeller synchrophaser to SYNC (if SK414-10 is not installed) or PHASE (if SK414-10 is installed) will eliminate the unpleasant audio beat accompanying unsynchronized operation. The propeller synchrophaser can also provide a significant reduction in cabin vibration.

With the propellers slightly out of synchronization so that an audio beat is obtained approximately once each 5 seconds, it should be noted that the vibration level of the cabin and instrument panel will increase and decrease at a rate of approximately once each 20 seconds. If SK414-10 is not installed, optimum operation will be obtained by manually synchronizing the propellers and positioning the synchrophaser to SYNC during the period of minimum vibration. If SK414-10 is installed, optimum operation will be obtained by manually synchronizing the propellers and positioning the synchrophaser to PHASE. Best propeller synchronizing is obtained by making the final adjustment of the propeller controls in a DECREASE RPM direction. For best operation, securely tighten the quadrant friction lock to prevent the slaved propeller control from creeping.

CRUISE

1. Cruise Power - 2100 to 2500 RPM and 15.0 to 24.5 inches Hg.
2. Mixtures - LEAN for desired cruise fuel flow as determined from your power computer. Recheck mixtures if power, altitude or OAT changes.
3. Cowl Flaps - OPEN or as required.
4. Propellers - SYNCHRONIZE manually.
5. Quadrant Friction Lock - TIGHTEN securely (With Synchrophaser Installed).
6. If SK414-10 Is Not Installed:
 - a. Propeller Synchrophaser - SYNC (Optional System). Light should illuminate continuously.
 - b. In Smooth Air After Propellers Are Synchronized - PHASE; Phasing Knob - ADJUST for desired phasing position (Optional System).

7. If SK414-10 Is Installed:
 - a. Propeller Synchrophaser - PHASING (Optional System). Light should illuminate continuously.
 - (1) Phasing Knob - ADJUST for desired phasing position.
8. Auxiliary Fuel Pumps:
 - a. Main Tanks - OFF or LOW if required.
 - b. Switching Tanks - LOW.
 - c. Auxiliary Tanks - OFF.
 - d. Crossfeeding - LOW.
9. Fuel Selectors - Left Engine - LEFT MAIN (Feel For Detent).
Right Engine - RIGHT MAIN (Feel For Detent).
 - a. If optional 40-gallon auxiliary tanks are installed, fuel selectors - MAIN TANKS for 60 minutes.
 - b. If optional 63-gallon auxiliary tanks are installed, fuel selectors - MAIN TANKS for 90 minutes.
 - c. Usable auxiliary fuel quantity is based on level flight.
 - d. If wing locker tanks are installed, fuel selectors - MAIN TANKS or, after wing locker tanks are transferred and main tank quantity is less than 180 pounds each - AUXILIARY TANKS.

NOTE

- Turn auxiliary fuel pumps to LOW and mixtures to FULL RICH when switching tanks.
- The auxiliary fuel tanks are to be used in cruise flight only.

- e. If wing locker tanks are installed, crossfeed - SELECT as required to maintain fuel balance after wing locker tank fuel transfer.
10. If oxygen use is desired, proceed as follows:
 - a. Mask - Connect mask and hose assembly and put mask on.

WARNING

Permit no smoking when using oxygen. Oil, grease, soap, lipstick, lip balm, and other fatty materials constitute a serious fire hazard when in contact with oxygen. Be sure hands and clothing are oil-free before handling oxygen equipment.

- b. Hose Coupling - Plug into oxygen outlet in the overhead console.
 - c. Oxygen Flow Indicator - Check Flow. (Indicator Toward Mask Indicates Proper Flow).
 - d. Disconnect hose coupling when not in use.
11. Trim Tabs - ADJUST.

Normal cruising requires between 50% and 70% power. The manifold pressure and RPM settings required to obtain these powers at various altitudes and outside air temperatures can be determined with your power computer. A maximum cruising power of approximately 75% (24.5 inches Hg. manifold pressure and 2500 RPM) may be used if desired. Various percent powers can be obtained with a number of combinations of manifold pressures, engine speeds, altitudes and outside air temperatures. However, at full throttle and constant engine speed, a specific power can be obtained at only one altitude for each given air temperature. For a given throttle setting,

select the lowest engine speed in the green arc range that will give smooth engine operation without evidence of laboring.

The use of lower power settings and the selection of cruise altitude on the basis of the most favorable wind conditions are significant factors that should be considered on every trip to reduce fuel consumption. Additional range can be achieved when operating at select power combinations, see Figure 5-21, by leaning to peak exhaust gas temperature (EGT) for Best Economy mixture. This setting results in an airspeed loss of 4 KTAS and range increase of 8% compared to the Recommended Lean mixture. Do not lean to the extent that engine roughness or excessive speed loss occurs.

CAUTION

Operation at Best Economy mixture is not recommended until oil consumption stabilizes or during the first 50 hours of operation. The purpose of this interval of operation at higher power levels (65% to 75% power) is to insure proper seating of the rings and is applicable to new engines, and engines in service following cylinder replacement or top overhaul of one or more cylinders.

When leaning, accomplish the procedure as precisely as possible. A little extra effort in setting the mixtures will yield significant dividends.

For normal cruise conditions, your power computer should be utilized to set the fuel flows. The power computer is based on true OAT; which is obtained by subtracting the ram rise from the indicated OAT. The power computer is marked with two fuel flow scales. These scales are provided to insure that you can obtain the maximum performance and utilization from your airplane. The inner fuel flow scale (marked Recommended Lean) should be utilized for all normal cruise performance. Data shown in Section 5 are based on Recommended Lean mixture. The outer fuel flow scale (marked Best Power) will provide maximum speed for a given power setting. The speed will be approximately one knot greater than the speed with Recommended Lean mixture.

The internal cowl flaps should normally be locked and left in the FULL OPEN position for all flight and ground operations, particularly on standard or above standard temperatures. During below standard temperatures, the cowl flaps should be adjusted to modulate the cylinder head temperatures within the normal operating range (green arc). Cowl flap position has no effect on cruise or climb performance.

If SK414-10 is not installed, best propeller synchronizing is obtained by making the final adjustment of the propeller controls in a DECREASE RPM direction. Manually synchronize the propellers as closely as possible and tighten the quadrant friction lock securely. During the period of minimum vibration, position the synchrophaser to SYNC. After propeller synchronizing has occurred (approximately 3 seconds after selecting the SYNC position) select the PHASE position for increased sensitivity. The phasing knob should then be adjusted until the desired sound and vibration characteristics are obtained. This setting will vary from flight to flight. During operation in any atmospheric turbulence, it is probable that greater or more rapid phasing changes will be required than are possible with the PHASE position. Under such conditions, operation in the SYNC position will provide the most satisfactory operation. On long cruise flights, where the slaved governor can eventually operate near either end of its operating

range, it may be necessary to periodically select the OFF position, reset the propeller controls and re-engage the synchrophaser.

If SK414-10 is installed, best propeller synchrophasing is obtained by making the final adjustment of the propeller controls in a DECREASE RPM direction. Manually synchronize the propellers as closely as possible and tighten the quadrant friction lock securely. Position the synchrophaser switch to PHASE. The phasing knob should then be adjusted until the desired sound and vibration characteristics are obtained. This setting will vary from flight to flight. If non-synchronized operation occurs during long cruise flights, manually re-synchronize the propeller controls as closely as possible and synchronized operation should reoccur. Securely tighten the quadrant friction lock, then adjust the phasing knob as desired.

If auxiliary fuel tanks are to be used, select main fuel for 60 minutes of flight (with 40-gallon auxiliary tanks) or 90 minutes of flight (with 63-gallon auxiliary tanks). This is necessary to provide space in the main tanks for vapor and fuel returned from the engine-driven fuel pumps when operating on auxiliary fuel. If sufficient space is not available in the main tanks for this diverted fuel, the tanks can overflow through the over-board fuel vents. After this period of time (60 or 90 minutes), set mixtures to FULL RICH, auxiliary fuel boost pumps to LOW, select the auxiliary fuel tank position on the fuel selectors and feel for detent. The engines will now operate on the auxiliary tank fuel; the fuel quantity indicator will automatically reference the auxiliary fuel tanks. Lean the mixtures as required.

Since part of the fuel from the auxiliary tanks is diverted back to the main tanks instead of being consumed by the engines, the auxiliary tanks will run dry sooner than may be anticipated; however, the main tank endurance will be increased by the returned fuel. The total usable fuel supply is available during cruising flight only. An engine failure or engine-driven pump failure results in the auxiliary fuel on the side of the failure being unusable. Operation on the auxiliary fuel tanks near the ground (below 1000 feet AGL) is not recommended.

After consuming the auxiliary tank fuel, set mixtures to FULL RICH, auxiliary fuel boost pumps to LOW, select the main tank position on the fuel selectors and feel for detent. After transitioning back to the main tanks, lean the mixtures as required and position auxiliary fuel pump switches to OFF.

If wing locker fuel is to be used, use the main tank fuel until 180 pounds or less remains in the main tank(s) which will receive the wing locker fuel; this will prevent overflowing of the main tank(s) when transferring the wing locker fuel.

There are no separate fuel selector controls for the wing locker fuel tanks. The wing locker fuel is pumped directly into the main tanks with a fuel transfer pump. Indicator lights are illuminated by pressure switches to indicate fuel has been transferred. Fuel should be cross-fed as required to maintain fuel balance after wing locker fuel has been transferred.

NOTE

Wing locker transfer pump switches provided on the instrument panel, energize the wing locker fuel transfer pumps for transferring fuel. These switches should be turned ON only to transfer fuel and turned OFF when the indicator lights come on indicating fuel has been transferred.

DESCENT

1. Power - AS REQUIRED to maintain engine temperatures in the green.
2. Cowl Flaps - AS REQUIRED.
3. Propeller Synchrophaser - AS REQUIRED (Optional System).
4. Mixtures - ADJUST for smooth operation with gradual enrichment as altitude is lost.
5. Altimeter - SET.

Descents should be initiated far enough in advance of estimated landing to allow a gradual rate of descent at cruising speed. It should be at approximately 500 fpm for passenger comfort, using enough power to keep the engines warm. This will prevent undesirable low cylinder head temperatures caused by low power settings at cruise speed. The optimum engine speed in a descent is usually the lowest one in the RPM green arc range that will allow cylinder head temperatures to remain in the recommended operating range.

During descents with progressive power reductions into rough air, position the propeller synchrophaser to SYNC for less sensitive control. The synchrophaser should be positioned to OFF for large power changes.

Upon completion of any large power changes, the synchrophaser may be re-engaged for the remainder of the descent. Manually synchronize the propellers, securely tighten the quadrant friction lock, then select the SYNC position of the synchrophaser.

During the descent, the mixtures should be gradually enriched to maintain smooth engine operation. This procedure will provide sufficient fuel flow for the descent; however, if a higher power setting (i.e. balked landing) is required before landing, the mixtures must be readjusted to obtain the correct fuel flow.

To prevent confusion in interpreting which 10,000-foot segment of altitude is being displayed on the altimeter, a striped warning segment is exposed on the face of the altimeter at all altitudes below 10,000 feet.

BEFORE LANDING

1. Fuel Selectors - Left Engine - LEFT MAIN (Feel For Detent).
Right Engine - RIGHT MAIN (Feel For Detent).
2. Auxiliary Fuel Pumps - ON.
3. Alternate Air Controls - CHECK IN.
4. Mixtures - FULL RICH or lean as required for smooth operation.
5. Propeller Synchrophaser - OFF (Optional System).
6. Propellers - FULL FORWARD.
7. Wing Flaps - DOWN 15° below 158 KIAS.
8. Landing Gear - DOWN below 138 KIAS.
9. Landing Gear Position Indicator Lights - Check down lights ON;
Unlocked Light - OFF.
10. Wing Flaps - DOWN 35° below 138 KIAS.
11. Minimum Multi-Engine Approach Speed - 93 KIAS.
12. Air Minimum Control Speed - 80 KIAS.

If fuel has been consumed at uneven rates between the two main tanks because of prolonged single-engine flight, it is desirable to balance the fuel load by operating both engines from the fullest tank. However, if there is sufficient fuel in both tanks, even though they may have unequal quantities, it is important to switch the left and right fuel selectors to the left and right main tanks, respectively; feel for detent, and check the auxiliary fuel pumps ON for the landing. This will provide an adequate fuel flow to each engine if a balked landing is necessary.

NOTE

Make sure weight does not exceed 5400 pounds before attempting landing.

Landing gear extension before landing is easily detected by a slight change in airplane trim and a slight "bump" as the gear locks down. Illumination of the gear-down indicator lights (green) is further proof that the gear is down and locked. The gear unlocked indicator light (red) will illuminate when the gear uplocks are released and will remain illuminated while the gear is in transit. The unlocked light will extinguish when the gear has locked down. If it is reasonably certain that the gear is down and one of the gear-down indicator lights is still not illuminated, the malfunction could be caused by a burned out light bulb. This can be checked by pushing the applicable gear-down indicator light. If the bulb is burned out, it can be replaced with the bulb from any post light, or the landing gear unlocked indicator light.

A simple last-minute recheck on final approach should confirm that all applicable switches are on, the gear-down indicator lights (green) are illuminated, the gear unlocked indicator light (red) is extinguished and the propeller and mixture controls are full forward.

Landings are simple and conventional in every respect. If power is used in landing approaches, it should be eased off cautiously near touch-down, because the "power-on" stall speed is considerably less than the "power-off" stall speed. An abrupt power reduction at five feet altitude could result in a hard landing if the airplane is near stall speed.

Landings on hard-surface runways are performed with 35° flaps and 93 KIAS during the approach, using as little power as practicable. A normal flare-out is made, and power is reduced in the flare-out. The landing is made on the main wheels first, and remaining engine power is cut immediately after touchdown. The nosewheel is gently lowered to the ground and brakes applied as required. Short field landings on rough or soft runways are done in a similar manner except that the nosewheel is lowered to the runway at a lower speed to prevent excessive nosegear loads.

Crosswind landings are performed with the least effort by using the crab method. However, either the wing-low, crab or combination method may be used. Crab the airplane into the wind in a normal approach using a minimum flap setting for the field length. Immediately before touchdown, the airplane is aligned with the flight path by applying down-wind rudder. The landing is made in nearly three-point attitude, and the nosewheel is lowered to the runway immediately after touchdown. A straight course is maintained with the steerable nosewheel and occasional braking if necessary.

BALKED LANDING

1. Increase engine speed to 2700 RPM and apply full throttle if necessary.
2. Mixtures - AS REQUIRED for balked landing power setting.
3. Balked Landing Transition Speed - 85 KIAS.
4. Landing Gear - RETRACT during IFR go-around or simulated IFR go-around.

NOTE

- Experience indicates that retracting the landing gear during an operational VFR go-around, when an immediate landing is contemplated, has been conducive to gear up landings.
- Always follow the Before Landing Checklist.

5. Reduce wing flap setting to 15°.
6. Trim airplane for climb.
7. Cowl Flaps - OPEN.
8. Retract wing flaps as soon as all obstacles are cleared and a safe altitude and airspeed are obtained.

AFTER LANDING

1. Auxiliary Fuel Pumps - LOW during landing roll.
2. Cowl Flaps - OPEN.
3. Wing Flaps - UP.

Heavy braking in the landing roll is not recommended because skidding the main wheels is probable with resulting loss of braking effectiveness and damage to the tires. It is best to leave the wing flaps fully extended throughout the landing roll to aid in decelerating the airplane. After leaving the active runway, the wing flaps should be retracted. Be sure the wing flaps switch is identified before placing it in the UP position. The auxiliary fuel pump switches are turned to LOW during the landing roll.

SHUTDOWN

1. Auxiliary Fuel Pumps - OFF.

NOTE

The fuel pumps must be turned OFF prior to stopping engines.

2. Avionics Master Switch - OFF.
3. All Switches Except Battery, Alternator and Magneto Switches - OFF.
4. Throttles - IDLE.
5. Mixtures - IDLE CUT-OFF.
6. Magneto Switches - OFF, after engines stop.

7. Battery and Alternators - OFF.
8. Parking Brake - SET if brakes are cool.
9. Control Lock(s) - INSTALL.
10. Fuel Selectors - OFF if a long period of inactivity is anticipated (Feel For Detent).
11. Cabin Door - CLOSE.

NOTE

To securely latch the cabin door from the outside, the exterior door handle must be rotated clockwise to its stop.

With the mixture levers in IDLE CUT-OFF, the fuel flow is effectively blocked at the fuel metering unit. Thus, it is unnecessary to place the fuel selectors in the OFF position if the airplane is receiving normal usage. However, if a long period of inactivity is anticipated, the fuel selectors should be turned OFF to preclude any possible fuel seepage that might develop through the metering valve.

NOTE

Do not leave the fuel selectors in an intermediate position, as fuel from the main tanks will transfer into the auxiliary tanks.

STALL

The stall characteristics of the airplane are conventional. Aural warning are provided by the stall warning horn between 5 and 10 KIAS above the stall in all configurations. The stall is also preceded by a mild aerodynamic buffet which increases in intensity as the stall is approached. The power-on stall occurs at a very steep angle with or without flaps. It is difficult to inadvertently stall the airplane during normal maneuvering.

MANEUVERING FLIGHT

No aerobatic maneuvers, including spins, are approved in this airplane; however, the airplane is conventional in all respects through the maneuvering range encountered in normal flight.

NIGHT FLYING

Before starting the engines for a night flight, the rheostats should be turned on and adjusted to provide enough illumination to check all switches, controls, etc.

Navigation Lights are then checked by observing illumination in the small peep holes in inboard leading edges of the wing tips and reflection from the pavement or ground below the tail light. The operation of the anti-collision lights should be checked by observing the reflections on the ground and on the wing tips and wings. The retractable landing lights (the)

right landing light is optional equipment) may be extended and checked momentarily. Returning the landing light switches to OFF turns the lights off, but leaves them extended ready for instant use.

Before taxi, the interior lighting intensity is normally decreased to the minimum at which all the controls and switches are visible. The taxi light should be turned on prior to taxiing at night. The landing lights, if used during taxiing, should be used intermittently to avoid excessive drain on the battery. In the engine runups, special attention should be directed to alternator operation by individually turning the selector switch to L ALT and R ALT and noting response on the voltmeter.

Night takeoffs are conventional, although the gear retraction operation is usually delayed slightly to insure that the airplane is well clear of the runway.

In cruising flight, the interior lighting intensity should be decreased to the minimum which will provide adequate instrument legibility.

COLD WEATHER OPERATION

Whenever possible, external preheat should be utilized in cold weather. The use of preheat materially reduces the severity of conditions imposed on both engines and electrical systems. It is the preferred or best method of starting engines in extremely cold weather. Preheat will thaw the oil trapped in the oil coolers and oil filters, which will probably be congealed prior to starting in very cold weather. Refer to the Airplane Service Manual for additional information when operating in extremely cold weather.

When the oil pressure gage is extremely slow in indicating pressure, it may be advisable to fill the pressure line to the gage with kerosene or JP-4.

NOTE

During cold weather operation it is advisable to rotate propellers through four complete revolutions, by hand, before starting engines.

If preheat is not available, external power should be used for starting because of the higher cranking power required and the decreased battery output at low temperatures. The starting procedure is normal; however, if the engines do not start immediately, it may be necessary to position the primer switch to LEFT or RIGHT for 5 to 10 seconds.

After a suitable warm-up period (2 to 5 minutes at 1000 RPM, if preheat is not used) accelerate the engines several times to higher RPM. The propellers should be operated through several complete cycles to warm the governors and propeller hubs. If the engines accelerate smoothly and the oil pressure remains normal and steady, the airplane is ready for takeoff.

WARNING

The wings and tail surfaces must be clear of ice, snow and frost prior to takeoff as flight characteristics can be adversely affected.

During operation in cold wet weather, the possibility of brake freezing exists; therefore, special precautions should be taken. If ice is found on the brakes during preflight inspection, heat the brakes with a ground heater until the ice melts and all traces of moisture are removed. If a ground heater is not available, spray or pour isopropyl alcohol (MIL-F-5566) on the brakes to remove the ice.

CAUTION

If brakes are deiced using alcohol, insure alcohol has evaporated from the ramp prior to starting engines as a fire could result.

If neither heat nor alcohol are available, frozen brakes can sometimes be freed by cycling the brakes asymmetrically while applying engine power. Caution should be exercised if the airplane is setting on ice or in close proximity to other parked airplanes.

After takeoff from slush-covered runways or taxiways, leave landing gear down for a short period, allowing wheels to spin. This will allow centrifugal force to throw off any accumulated slush which should preclude frozen brakes on landing. Insure wheels are stopped before retracting wheels to prevent buildup of ice or slush in the wheel wells.

During cruise, the propellers should be exercised at half-hour intervals to flush the cold oil from the governors and propeller hubs. Electrical equipment should be managed to assure adequate alternator charging throughout the flight, since cold weather adversely affects battery capacity.

During letdown, watch engine temperatures closely and carry sufficient power to maintain them above operating minimums.

The pitot heat switch should be turned ON at least 5 minutes before entering potential icing conditions (2 minutes if on ground) so that these units will be warm enough to prevent formation of ice. Preventing ice is preferable to attempting its removal once it has formed.

ALTERNATE INDUCTION AIR

The induction system employed on these engines is considered to be nonicing. However, manually operated alternate induction air is provided to assure satisfactory operation should the induction air filter become obstructed. Should a decrease in manifold pressure be experienced when flying in icing conditions, the alternate air doors should be manually opened. This will provide continued satisfactory engine operation.

The use of alternate intake air results in a decrease in engine power due to higher induction air temperatures and lower manifold pressure available. Therefore, it is recommended that the alternate induction air system be used only if icing conditions are expected.

Should additional power be required, the following procedures may be employed:

1. Increase RPM as required.
2. Move throttles forward to maintain desired manifold pressure.
3. Readjust mixture controls for smooth engine operation.

During ground operation, the alternate air doors should be closed to prevent engine damage caused by ingesting debris through unfiltered air ducts.

NOISE ABATEMENT

Increased emphasis on improving the quality of our environment requires renewed effort on the part of all pilots to minimize the effect of airplane noise on the public.

We, as pilots, can demonstrate our concern for environmental improvement by application of the following suggested procedures, and thereby tend to build public support for aviation:

1. Pilots operating airplanes under VFR over outdoor assemblies of persons, recreational and park areas, and other noise-sensitive areas should make every effort to fly not less than 2000 feet above the surface, weather permitting, even though flight at a lower level may be consistent with the provisions of government regulations.
2. During departure from or approach to an airport, climb after take-off and descent for landing should be made so as to avoid prolonged flight at low altitude near noise-sensitive areas. Avoidance of noise-sensitive areas, if practical, is preferable to over-flight at relatively low altitudes.

NOTE

The preceding recommended procedures do not apply where they would conflict with Air Traffic Control clearances or instructions, or where, in the pilot's judgment, an altitude of less than 2000 feet is necessary to adequately exercise his duty to see and avoid other airplanes.

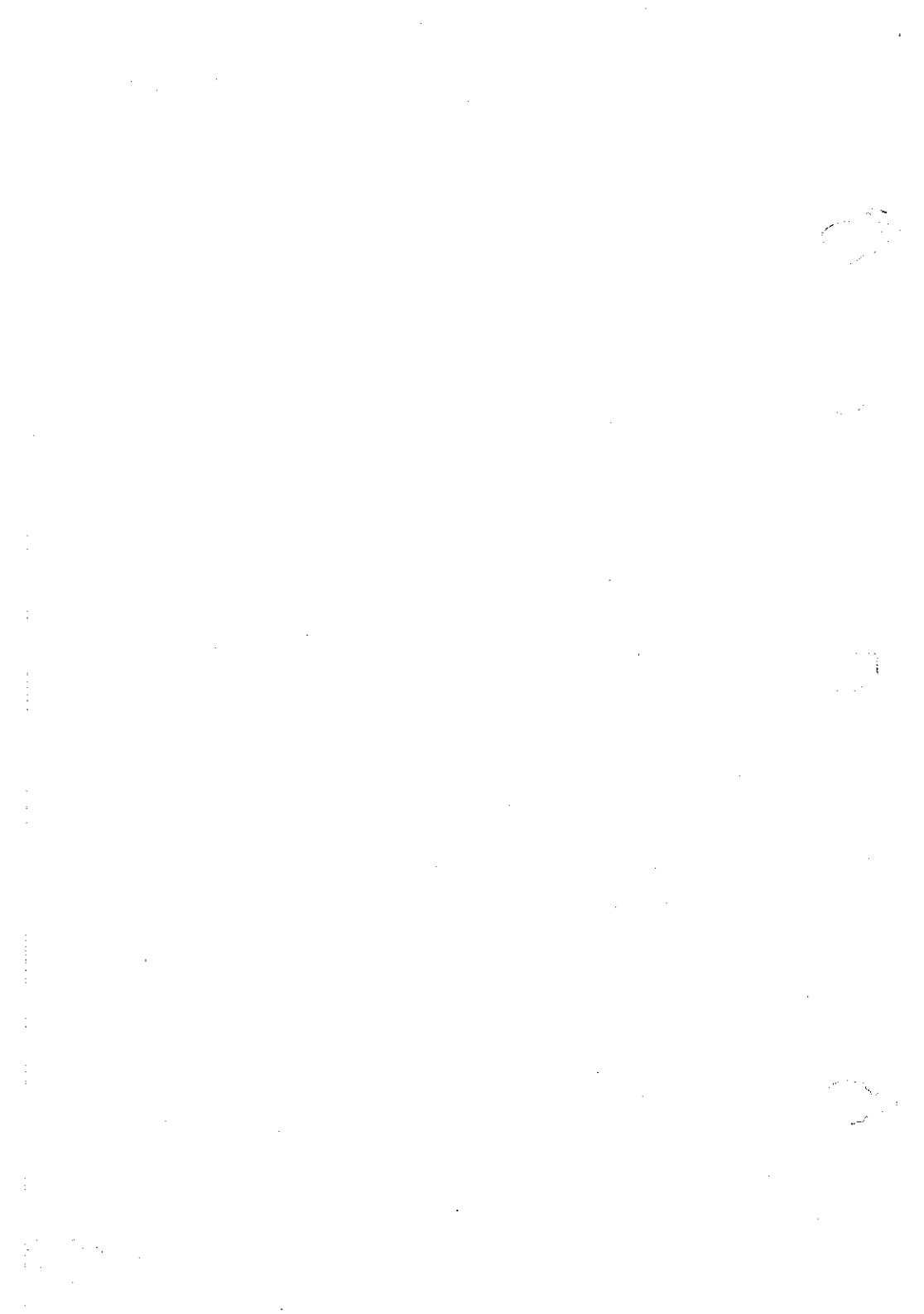

THE FOLLOWING WEATHER CONDITIONS MAY BE CONDUCTIVE TO SEVERE IN-FLIGHT ICING:

- Visible rain at temperatures below 0 degrees Celsius ambient air temperature;
- Droplets that splash or splatter on impact at temperatures below 0 degrees Celsius ambient air temperature.

PROCEDURES FOR EXITING A SEVERE ICING ENVIRONMENT: *(These procedures are applicable to all flight phases from take-off to landing.)*

Monitor the ambient air temperature.

While severe icing may form at temperatures as cold as -18 degrees Celsius, increased vigilance is warranted at temperatures around freezing when visible moisture is present.

CONTINUED ON NEXT LEAF

5

6

7

If the visual cues which are specified in the Limitations Section of the AFM for identifying severe icing conditions are observed, accomplish the following:

- Immediately request priority handling from Air Traffic Control to facilitate a route or an altitude change to exit the severe icing conditions in order to avoid extended exposure to flight conditions more severe than those for which the aircraft has been certificated.
- Avoid abrupt and excessive manoeuvring that may exacerbate control difficulties.
- Do not engage the autopilot.
- If the autopilot had previously been engaged, hold the control wheel firmly and disengage the autopilot.
- If an unusual roll response or un-commanded roll control movement is observed, reduce the angle-of-attack.
- Do not extend flaps when holding in icing conditions. Operation with flaps extended can result in a reduced wing angle-of-attack, with the possibility of ice forming on the upper surface further aft on the wing than normal, possibly aft of the protected area.
- If the flaps are extended, do not retract them until the airframe is clear of ice.
- Report these weather conditions to Air Traffic Control.

Notes 1: Certificate of Registration holders should initiate action to ensure notification of this change is conveyed to any person who may operate their aircraft as pilot in command.

Notes 2: FAA AD 94-08-28 refers.

Certification for accomplishment of this Directive may be carried out:

- a. after a copy of this Directive is included in the appropriate sections of the aircraft's AFM; and
- b. may be carried out at a minimum, by the holder of a private pilot's licence.

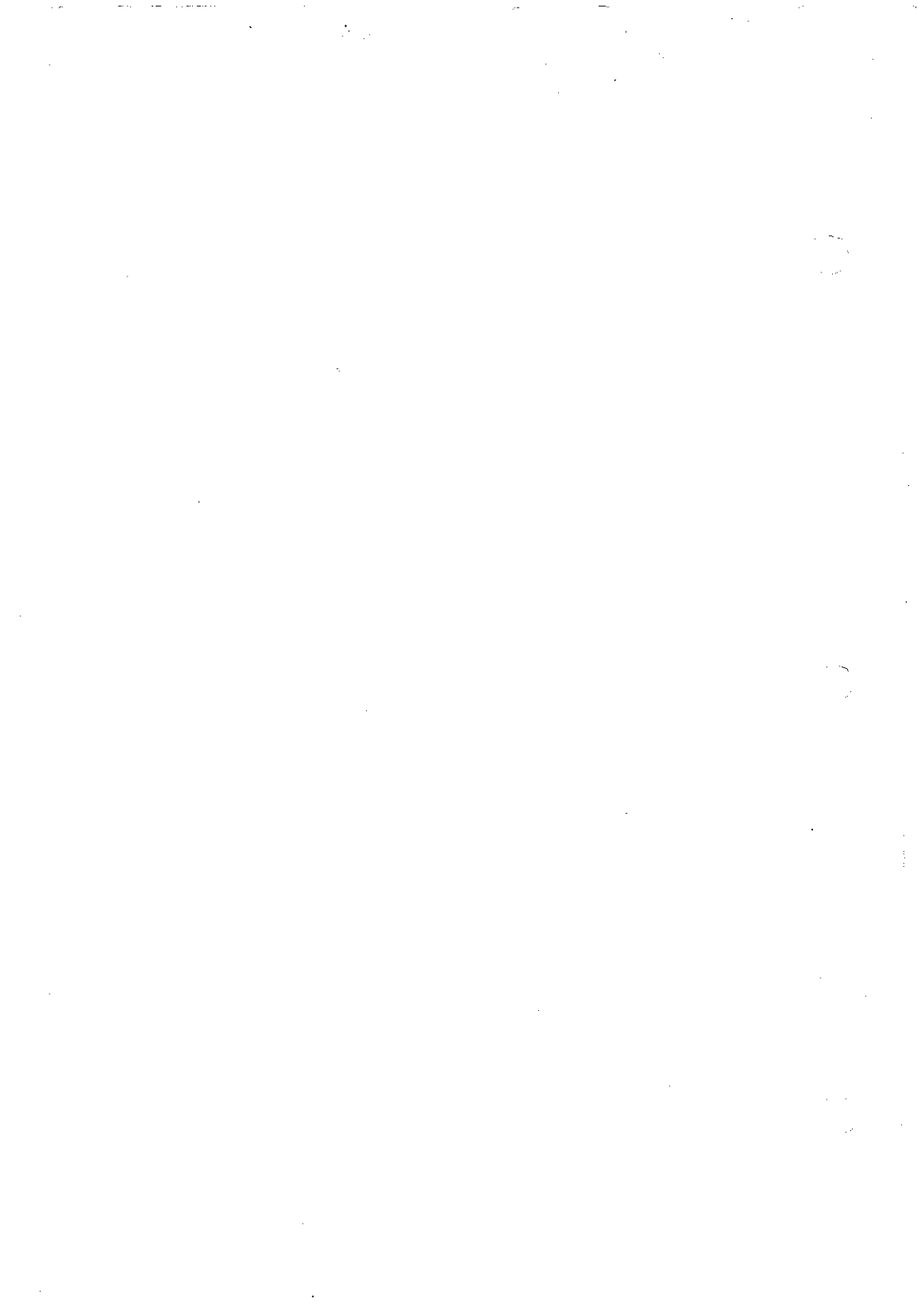

SECTION 5 PERFORMANCE TABLE OF CONTENTS

	Page		Page
INTRODUCTION	5-1	MAXIMUM PERFORMANCE	
INTRODUCTION TO TABULATED		TAKEOFF DISTANCE	5-24
PERFORMANCE	5-2	ACCELERATE STOP DISTANCE	5-26
Example	5-2	ACCELERATE GO DISTANCE	5-27
SAMPLE FLIGHT	5-5	RATE-OF-CLIMB	
Airplane Configuration	5-5	Maximum Climb	5-28
Takeoff Airport		Cruise Climb	5-29
Conditions	5-5	Single-Engine	5-30
Cruise Conditions	5-6	BALKED LANDING CLIMB	
Landing Airport		Rate-of-Climb	5-31
Conditions	5-6	SINGLE-ENGINE SERVICE	
Sample Calculations	5-6	CEILING	5-32
AIR SPEED CALIBRATION		TIME, FUEL AND DISTANCE TO	
Normal Static Source	5-13	CLIMB	
Alternate Static Source	5-14	Maximum Climb	5-33
ALTIMETER CORRECTION		Cruise Climb	5-34
Normal Static Source	5-15	CRUISE PERFORMANCE	
Alternate Static Source	5-16	2500 Feet	5-35
TEMPERATURE RISE DUE TO RAM		5000 Feet	5-35
RECOVERY	5-17	7500 Feet	5-36
TEMPERATURE CONVERSION		10,000 Feet	5-36
°F to °C	5-18	15,000 Feet	5-37
PRESSURE CONVERSION -		RANGE PROFILE	5-38
INCHES OF MERCURY TO		ENDURANCE PROFILE	5-39
MILLIBARS	5-19	HOLDING TIME	5-40
STALL SPEEDS	5-20	TIME, FUEL AND DISTANCE TO	
WIND COMPONENT	5-21	DESCEND	5-41
NORMAL TAKEOFF DISTANCE	5-22	NORMAL LANDING DISTANCE	5-42
		FUEL FLOW SCHEDULE	5-44

INTRODUCTION

Section 5 of the Pilot's Operating Handbook contains all the performance information required to operate the airplane safely and to help you plan your flights in detail with reasonable accuracy. Safe and precise operation of the airplane requires the pilot to be thoroughly familiar and understand the data and calculations of this section.

The data on these graphical and tabular charts have been compiled from actual flight tests, with the airplane and engines in good condition, using average pilot techniques. Note that the cruise performance data makes no allowance for wind and/or navigational errors. Allowances for start, taxi, takeoff, climb, descent and 45 minutes reserve are provided in the range profile chart.

To determine pressure altitude at origin and destination airports, add 100 feet to field elevation for each .1 inch Hg. below 29.92, or subtract 100 feet from field elevation for each .1 inch Hg. above 29.92.

INTRODUCTION TO TABULATED PERFORMANCE

The performance tables are presented in increments of temperature, altitude and any other variables involved. Performance for a given set of conditions can be approximated as follows:

- (1) Takeoff, Accelerate Stop, Accelerate Go, Landing - Enter tables at the next higher increment of weight, altitude and temperature.
- (2) Cruise - Enter tables at next lower increment of temperature and altitude.

To obtain exact performance values from the tables, it is necessary to interpolate between the increment values. The following is an example of approximation and interpolation, using an excerpt from the Normal Takeoff Distance Chart.

EXAMPLE

Given:

Weight 5250 Pounds
 Temperature (16°C) 61°F
 Pressure Altitude 2400 Feet
 Headwind 19 Knots

Find:

Takeoff Speed _____ KIAS
 Ground Roll _____ Feet
 Total Distance to Clear 50-Foot Obstacle _____ Feet

Weight Pounds	Takeoff and Climb Speed KIAS	Pressure Altitude Feet	10°C (50°F)		20°C (68°F)	
			Ground Roll - Feet	Total Distance to Clear 50-Ft - Feet	Ground Roll - Feet	Total Distance to Clear 50-Ft - Feet
5500	92	2000	2020	2470	2240	2710
		3000	2300	2800	2470	3010
5100	89	2000	1680	2040	1800	2190
		3000	1850	2250	1990	2420

Approximation Method

Extract from the chart the next increment of weight, altitude and temperature which is more conservative than the actual conditions [i.e.: 5500 pounds, 3000 feet and 20°C (68°F)].

Takeoff and Climb Speed 92 KIAS
 Ground Roll 2470 Feet
 Total Distance to Clear 50-Foot Obstacle 3010 Feet

Interpolation Method

If the approximation method yields a value larger than can be tolerated, a more exact value should be determined using the interpolation method.

The example weight (5250 pounds) is 5100 pounds plus 150/400 or .375 times the difference between 5100 pounds and 5500 pounds [i.e.: 5100-pound value + .375 (5500-pound value - 5100-pound value)]

The example pressure altitude (2400 feet) is 2000 feet plus 400/1000 or .4 times the difference between 2000 feet and 3000 feet [i.e.: 2000-foot value + .4 (3000-foot value - 2000-foot value)].

The example temperature of 16°C (61°F) is 10°C plus 6/10 or .6 times the difference between 10°C and 20°C [i.e.: 10°C value + .6 (20°C value - 10°C value)].

Interpolating Values for Normal Takeoff Distance:

$$\begin{aligned}\text{Takeoff and Climb Speed} &= 5100\text{-pound value} + [.375 (5500\text{-pound} \\ &\quad \text{value} - 5100\text{-pound value})] \\ &= 89 \text{ KIAS} + [.375 (92 \text{ KIAS} - 89 \text{ KIAS})] \\ &= 89 \text{ KIAS} + [1.1 \text{ KIAS}] \\ &= \underline{90 \text{ KIAS}}\end{aligned}$$

Ground Roll (7 interpolations required)

$$\begin{aligned}\text{Altitude interpolation} &= 2000\text{-foot value} + [.4 (3000\text{-foot value} - \\ \text{at } 10^{\circ}\text{C (50}^{\circ}\text{F) and 5500} &\quad \text{2000-foot value})] \\ \text{pounds} &= 2020 \text{ feet} + [.4 (2300 \text{ feet} - 2020 \text{ feet})] \\ &= 2020 \text{ feet} + [112 \text{ feet}] \\ &= \underline{2132 \text{ feet}}\end{aligned}$$

$$\begin{aligned}\text{Altitude interpolation} &= 2000\text{-foot value} + [.4 (3000\text{-foot value} - \\ \text{at } 20^{\circ}\text{C (68}^{\circ}\text{F) and 5500} &\quad \text{2000-foot value})] \\ \text{pounds} &= 2240 \text{ feet} + [.4 (2470 \text{ feet} - 2240 \text{ feet})] \\ &= 2240 \text{ feet} + [92 \text{ feet}] \\ &= \underline{2332 \text{ feet}}\end{aligned}$$

$$\begin{aligned}\text{Altitude interpolation} &= 2000\text{-foot value} + [.4 (3000\text{-foot value} - \\ \text{at } 10^{\circ}\text{C (50}^{\circ}\text{F) and 5100} &\quad \text{2000-foot value})] \\ \text{pounds} &= 1680 \text{ feet} + [.4 (1850 \text{ feet} - 1680 \text{ feet})] \\ &= 1680 \text{ feet} + [68 \text{ feet}] \\ &= \underline{1748 \text{ feet}}\end{aligned}$$

Altitude interpolation at 20°C (68°F) and 5100 pounds

$$= 2000\text{-foot value} + [.4 (3000\text{-foot value} - 2000\text{-foot value})]$$

$$= 1800 \text{ feet} + [.4 (1990 \text{ feet} - 1800 \text{ feet})]$$

$$= 1800 \text{ feet} + [76 \text{ feet}]$$

$$= \underline{1876 \text{ feet}}$$

The Normal Takeoff Distance chart, with altitude interpolation, looks as follows:

Weight Pounds	Takeoff and Climb Speed KIAS	Pressure Altitude Feet	10°C (50°F)		20°C (68°F)	
			Ground Roll - Feet	Total Distance to Clear 50-Ft - Feet	Ground Roll - Feet	Total Distance to Clear 50-Ft - Feet
5500	92	2400	2132	--	2332	--
5100	89	2400	1748	--	1876	--

Weight interpolation at 10°C (50°F) and 2400 feet

$$= 5100\text{-pound value} + [.375 (5500\text{-pound value} - 5100\text{-pound value})]$$

$$= 1748 \text{ feet} + [.375 (2132 \text{ feet} - 1748 \text{ feet})]$$

$$= 1748 \text{ feet} + [144 \text{ feet}]$$

$$= \underline{1892 \text{ feet}}$$

Weight interpolation at 20°C (68°F) and 2400 feet

$$= 5100\text{-pound value} + [.375 (5500\text{-pound value} - 5100\text{-pound value})]$$

$$= 1876 \text{ feet} + [.375 (2332 \text{ feet} - 1876 \text{ feet})]$$

$$= 1876 \text{ feet} + [171 \text{ feet}]$$

$$= \underline{2047 \text{ feet}}$$

The Normal Takeoff Distance chart, with altitude and weight interpolation, looks as follows:

Weight Pounds	Takeoff and Climb Speed KIAS	Pressure Altitude Feet	10°C (50°F)		20°C (68°F)	
			Ground Roll - Feet	Total Distance to Clear 50-Ft - Feet	Ground Roll - Feet	Total Distance to Clear 50-Ft - Feet
5250	90	2400	1892	--	2047	--

$$\begin{aligned}
 \text{Temperature interpolation} &= 10^{\circ}\text{C} (50^{\circ}\text{F}) \text{ value} + [.6 (20^{\circ}\text{C} (68^{\circ}\text{F}) \\
 &\text{at 2400 feet and 5250} \quad \text{value} - 10^{\circ}\text{C} (50^{\circ}\text{F}) \text{ value}]] \\
 \text{pounds} & \\
 &= 1892 \text{ feet} + [.6 (2047 \text{ feet} - 1892 \text{ feet})] \\
 &= 1892 \text{ feet} + [93 \text{ feet}] \\
 &= \underline{1985 \text{ feet}}
 \end{aligned}$$

The Normal Takeoff Distance chart, with altitude, weight and temperature, looks as follows:

Weight Pounds	Takeoff and Climb Speed KIAS	Pressure Altitude Feet	16°C (61°F)	
			Ground Roll - Feet	Total Distance to Clear 50-Ft - Feet
5250	90	2400	1985	--

Ground Roll with 19-knot headwind

$$\begin{aligned}
 &= 1985 \text{ feet} - [1985 \text{ feet} (\frac{19 \text{ knots headwind}}{10 \text{ knots headwind}}) (7\%)] \\
 &= 1985 \text{ feet} - 264 \text{ feet} \\
 &= \underline{1721 \text{ feet}}
 \end{aligned}$$

Total Distance to Clear 50-Foot Obstacle (7 interpolations required)

The interpolations required are identical to the ground roll interpolations, except "total distance to clear 50-foot obstacle" values are substituted for the "ground roll" values.

The interpolated value for the total distance to clear 50-foot obstacle is 2414 feet (no wind) and 2093 feet (19-knot headwind).

SAMPLE FLIGHT

The following is an example of a typical flight using the performance data contained in Figure 5-1 through 5-27. The approximation method is used in tabular performance except where noted.

AIRPLANE CONFIGURATION

Airplane Weight 5250 Pounds
 Usable Fuel Load 978 Pounds

TAKEOFF AIRPORT CONDITIONS

Field Length 5000 Feet (Runway 23)
 Temperature 16°C (61°F)
 Field Pressure Altitude 2400 Feet
 Wind 270° at 25 Knots
 Obstacles None

CRUISE CONDITIONS

Distance	600 Nautical Miles
Cruise Altitude	9500 Feet
Temperature	0°C (32°F)
Wind	15-Knot Tailwind
Power	Maximum Recommended Cruise Power at Recommended Lean Mixture

LANDING AIRPORT CONDITIONS

Field Length	3500 Feet (Runway 19)
Temperature	7°C (45°F)
Field Pressure Altitude	1700 Feet
Wind	210° at 17 Knots
Landing Weight	To be Calculated
Obstacles	50-Foot Trees

SAMPLE CALCULATIONS

Wind Component Chart (Figure 5-9)

- (1) The angle between the runway and the prevailing wind is 40°.
- (2) Enter Figure 5-9 on the 40° wind line and proceed out to the intersection with the 25-knot arc.
- (3) Read horizontally left from this intersection, the headwind component is 19 knots.

Normal Takeoff Distance (Figure 5-10)

- (1) Enter Figure 5-10 at 5500 pounds weight; the takeoff and climb speed is 92 KIAS.
- (2) Proceed horizontally right from 3000-foot pressure altitude to the vertical columns for 20°C (68°F). The takeoff ground run is 2470 feet and the total distance required to clear a 50-foot obstacle is 3010 feet without wind correction. With a 19-knot headwind component, the corrected takeoff ground run is 2141 feet and the corrected total distance required is 2610 feet.

$$\frac{19 \text{ Knots Headwind}}{10 \text{ Knots Headwind}} (7\%) = 13.3\%$$

$$\begin{aligned} \text{Corrected Takeoff} &= 2470 \text{ feet} - [13.3\% (2470 \text{ feet})] \\ \text{Ground Run} &= 2470 \text{ feet} - [329 \text{ feet}] \\ &= \underline{2141 \text{ feet}} \end{aligned}$$

$$\begin{aligned} \text{Corrected Total} &= 3010 \text{ feet} - [13.3\% (3010 \text{ feet})] \\ \text{Distance Required} &= 3010 \text{ feet} - [400 \text{ feet}] \\ &= \underline{2610 \text{ feet}} \end{aligned}$$

Accelerate Stop Distance (Figure 5-12)

- (1) Enter Figure 5-12 at 5500 pounds weight; engine failure speed is 92 KIAS.
- (2) Proceed horizontally right from 3000-foot pressure altitude to the vertical columns for 20°C. The distance required to accelerate to 92 KIAS and stop is 4650 feet without wind correction. With a 19-knot headwind component, the accelerate stop distance can be reduced by:

$$\frac{19 \text{ Knots Headwind}}{4 \text{ Knots Headwind}} (3\%) = 14.25\%$$

Corrected Accelerate = 4650 feet - [14.25% (4650 feet)]

Stop Distance

$$= 4650 \text{ feet} - [663 \text{ feet}]$$

$$= \underline{3987 \text{ feet}}$$

Accelerate Go Distance (Figure 5-13)

- (1) Enter Figure 5-13 at 5500 pounds weight; engine failure speed is 92 KIAS.
- (2) Proceed horizontally right from 3000-foot pressure altitude to the vertical columns for 20°C. The distance required to clear a 50-foot obstacle, after losing an engine at 92 KIAS, is 10,350 feet without wind correction. With a 19-knot headwind component, the distance can be reduced by:

$$\frac{19 \text{ Knots Headwind}}{10 \text{ Knots Headwind}} (6\%) = 11.4\%$$

Corrected Accelerate = 10,350 feet - [11.4% (10,350 feet)]

Go Distance

$$= 10,350 \text{ feet} - [1180 \text{ feet}]$$

$$= \underline{9170 \text{ feet}}$$

NOTE

- The distance required to accelerate go using the approximation method is so great, in view of the 5000-foot runway available, that a more exact value should be obtained using the interpolation method.
- The interpolation method gives an accelerate go distance of 5170 feet without wind or 4581 feet with 19 knots of headwind.

Rate-Of-Climb — Maximum Climb (Figure 5-14)

- (1) Enter Figure 5-14 at 16°C (61°F).
- (2) Proceed vertically up to the 2400-foot pressure altitude line.
- (3) Proceed horizontally right to the reference line. Follow the slope of the adjacent rate-of-climb lines until intersecting the vertical 5250-pound line.
- (4) Proceed horizontally right to obtain rate-of-climb. (1540 Feet per minute)
- (5) Enter the climb speed data to determine the climb speed corrected for 5250 pounds and 2400 feet. (103 KIAS)

Rate-Of-Climb — Cruise Climb (Figure 5-15)

- (1) Enter Figure 5-15 at 5500 pounds weight.
- (2) Proceed horizontally right from the 2000-foot pressure altitude to the vertical column for 20°C to obtain rate-of-climb, (888 Feet per minute). Note that cruise rate-of-climb increases with altitude between sea level and approximately 5200 feet pressure altitude.
- (3) Climb speed is 120 KIAS for all conditions.

Rate-Of-Climb — Single Engine (Figure 5-16)

- (1) Enter Figure 5-16 at 16°C (61°F).
- (2) Proceed vertically up to the 2400-foot pressure altitude line.
- (3) Proceed horizontally right to the reference line. Follow the slope of the adjacent rate-of-climb lines until intersecting the vertical 5250-pound line.
- (4) Proceed horizontally right to obtain rate-of-climb. (300 Feet per minute)
- (5) Enter the climb speed data to determine the climb speed corrected for 5250 pounds and 2400 feet. (101 KIAS)

Time, Fuel And Distance To Climb — Cruise Climb (Figure 5-20)

Time, fuel and distance to climb are determined by finding the difference between the airport and the cruise conditions; thus, two calculations are required, one for the airport condition and the second for the cruise condition.

Airport Condition:

- (1) Enter Figure 5-20 at 16°C (61°F).
- (2) Proceed vertically up to 2400-foot pressure altitude line.
- (3) Proceed horizontally right to the 5250-pound line.
- (4) Proceed vertically down to obtain time to climb (2.5 minutes), fuel to climb (10 pounds) and distance to climb (5 nautical miles).

Cruise Condition:

- (5) Enter Figure 5-20 at 0°C (32°F).
- (6) Proceed vertically up to 9500-foot pressure altitude line.
- (7) Proceed horizontally right to the 5250-pound line.
- (8) Proceed vertically down to obtain time to climb (9.5 minutes), fuel to climb (32 pounds) and distance to climb (20 nautical miles).

Final Calculations: = Cruise time to climb - Airport time to
Time to Climb climb

= 9.5 minutes - 2.5 minutes

= 7 minutes

$$\begin{aligned}
 \text{Fuel to Climb} &= \text{Cruise fuel to climb} - \text{Airport fuel to climb} \\
 &= 32 \text{ Pounds} - 10 \text{ pounds} \\
 &= \underline{22 \text{ pounds}} \text{ (add 25 pounds for start, taxi and runup) (47 pounds total)} \\
 \\
 \text{Distance to Climb} &= \text{Cruise distance to climb} - \text{Airport distance to climb} \\
 &= 20 \text{ nautical miles} - 5 \text{ nautical miles} \\
 &= 15 \text{ nautical miles} \\
 \\
 &\text{Adjusted for wind (use 60\% of the wind at altitude for climb wind),} \\
 &= 15 \pm \text{wind contribution} \\
 &= 15 + \left[\frac{7 \text{ minutes}}{60 \text{ minutes}} (.6 \times 15 \text{ knots}) \right] \\
 &= 15 \text{ nautical miles} + 1.05 \text{ nautical miles} \\
 &= \underline{16 \text{ nautical miles}}
 \end{aligned}$$

Time, Fuel And Distance To Descend (Figure 5-25)

Time, fuel and distance to descend are determined by finding the difference between the cruise and the landing airport conditions; thus two calculations are required, one for the cruise condition and the second for the landing airport condition.

Cruise Condition:

- (1) Enter Figure 5-25 at the cruise altitude of 9500 feet.
- (2) Proceed horizontally right to the guideline.
- (3) Proceed vertically down to obtain time to descend (19 minutes), fuel to descend (48 pounds) and distance to descend (57 nautical miles).

Landing Airport Condition:

- (4) Enter Figure 5-25 at the airport altitude of 1700 feet.
- (5) Proceed horizontally right to the guideline.
- (6) Proceed vertically down to obtain time to descend (3.0 minutes), fuel to descend (8 pounds) and distance to descend (9 nautical miles).

Final Calculations:

$$\begin{aligned}
 \text{Time to Descend} &= \text{Cruise time to descend} - \text{Airport time to descend} \\
 &= 19.0 \text{ minutes} - 3.0 \text{ minutes} \\
 &= \underline{16.0 \text{ minutes}}
 \end{aligned}$$

Fuel to Descend = Cruise fuel to descend - Airport fuel to descend

= 48 pounds - 8 pounds

= 40 pounds

Distance to Descend = Cruise distance to descend - Airport distance to descend.

= 57 nautical miles - 9 nautical miles

= 48 nautical miles

Adjusted for wind (use 40% of the wind at altitude for descent wind),

= 48 + wind contribution

= 48 + [$\frac{16 \text{ minutes}}{60 \text{ minutes}}$ (.4 x 15 knots)]

= 48 nautical miles + 1.6 nautical miles

= 50 nautical miles

Cruise Performance With Recommended Lean Mixture (Figure 5-21)

Maximum recommended cruise may be obtained with 2500 RPM and 24.5 Inches Hg. manifold pressure below 5200 feet pressure altitude, and 2500 RPM and full throttle above 5200 feet pressure altitude.

The approximation method for extracting data from the cruise tables is to select the next lower temperature and altitude values, which are generally conservative with respect to fuel economy.

- (1) Enter the 7500-foot data at 2500 RPM and 23.2 Inches Hg. manifold pressure.
- (2) Use 0°C (32°F) data for a power of 75.2% airspeed of 192 KTAS and a total fuel flow of 188 pounds per hour.
- (3) Correcting for a weight of 5250 pounds, the airspeed increases to:

$$192 \text{ KTAS} + \frac{(5500 \text{ pounds} - 5250 \text{ pounds})}{400 \text{ pounds}} (3 \text{ KTAS}) =$$

$$192 \text{ KTAS} + 1.9 \text{ KTAS} = \underline{194 \text{ KTAS}}$$

Using the interpolation method, interpolating altitude, temperature and weight, the actual performance is 68.5% power, 191 KTAS and total fuel flow of 172 pounds per hour.

In the above calculations, for convenience, the weight was assumed to be equal to the takeoff weight of 5250 pounds. More realistic data can be determined if the average cruise weight is used. This average cruise weight is determined as follows:

$$\begin{aligned} \text{Cruise} &= \text{Total} - \text{climb} - \text{descent} \\ \text{Fuel} &= \frac{\text{distance}}{\text{True}} + \frac{\text{distance}}{\text{wind}} \times [\text{Total fuel flow per hour}] \\ &\quad \text{airspeed} \quad \text{correction} \end{aligned}$$

$$\begin{aligned} &= \frac{600}{191 \text{ KTAS}} + \frac{16}{15 \text{ Knot Tailwind}} + \frac{50}{\text{Nautical Miles}} \times [172 \text{ pounds per hour}] \\ &= \frac{534 \text{ Nautical miles}}{206} \times 172 \text{ pounds per hour} \end{aligned}$$

$$= 2.59 \text{ hours} \times 172 \text{ pounds per hour}$$

$$= \underline{446 \text{ pounds}} \quad \text{Cruise}$$

$$\text{Average} = \text{Takeoff weight} - \text{start, taxi and climb fuel} - \frac{\text{fuel}}{2}$$

$$\text{Cruise} = 5250 \text{ pounds} - 47 \text{ pounds} - \frac{446 \text{ pounds}}{2}$$

$$= \underline{4980 \text{ pounds}}$$

$$\text{Average} = \text{True airspeed from Figure 5-21} + \text{weight correction}$$

$$\text{Cruise} = 191 \text{ KTAS} + 3.8 \left(\frac{270}{400} \right)$$

$$= \underline{194 \text{ KTAS}}$$

$$\text{Average} = 194 \text{ KTAS} + \text{tailwind}$$

$$\text{Ground} = 194 \text{ KTAS} + 15 \text{ knots}$$

$$= \underline{209 \text{ knots}}$$

$$\text{Distance} = \text{Total distance} - \text{Climb distance} - \text{Descent distance}$$

$$\text{During} = 600 - 16 - 50$$

$$= \underline{534 \text{ Nautical Miles}}$$

$$\text{Time} = \frac{\text{Cruise distance}}{\text{ground speed}}$$

$$\text{During} = \frac{534}{209}$$

$$= \underline{2.56 \text{ hours}}$$

Normal Landing Distance (Figure 5-26)

$$\text{Landing Weight} = \text{Takeoff weight} - \text{climb fuel} - \text{cruise fuel} - \text{descent fuel}$$

$$= 5250 \text{ pounds} - 47 \text{ pounds} - 446 \text{ pounds} - 40 \text{ pounds}$$

$$= \underline{4717 \text{ pounds}}$$

Wind = 210° at 17 knots. Determine headwind component from Figure 5-9. (16 knots headwind)

Enter Figure 5-26 at 5000 pounds; the approach speed is 89 KIAS. Proceed horizontally right from 2000-foot pressure altitude to the vertical column for 10°C (50°F). The landing distance ground roll is 580 feet and the total distance required to clear a 50-foot obstacle is 1730 feet without wind correction. With a 16-knot headwind component, the corrected ground roll distance is 510 feet and the corrected total distance required is 1522 feet.

$$\frac{16 \text{ Knots Headwind}}{4 \text{ Knots Headwind}} (3\%) = 12\%$$

Corrected Landing = 580 feet - [12% (580)]
Ground Roll = 580 feet - 70 feet
= 510 feet

Corrected Total = 1730 - [12% (1730)]
Distance Required = 1730 feet - 208 feet
= 1522 feet

Rate-Of-Climb — Bailed Landing Climb (Figure 5-17)

- (1) Enter Figure 5-17 at 7°C (45°F).
- (2) Proceed vertically up to the 1700-foot pressure altitude line.
- (3) Proceed horizontally right to the weight reference line. Follow the guidelines up and to the right until intersecting the vertical 4717-pound weight line.
- (4) Proceed horizontally right to determine the rate-of-climb. (1160 Feet per minute)

Total Fuel Required = Start, taxi and climb fuel + cruise fuel + descent fuel
= 47 pounds + 446 pounds + 40 pounds = 533 pounds (Without Holding Fuel)
or 533 pounds + 89 pounds = 622 pounds (With 45 Minutes Holding Fuel)

Holding Time (Figure 5-24)

To determine holding time, the fuel available for holding must be determined.

Fuel Available for Holding = Initial fuel - [start, taxi and climb fuel + cruise fuel + descent fuel]
= 978 pounds - [47 pounds + 446 pounds + 40 pounds]
= 445 pounds

- (1) Enter Figure 5-24 at 445 pounds of fuel available.
- (2) Proceed vertically up to the intersection with the guideline.
- (3) Proceed horizontally left to obtain holding time available. (3.75 hours)

AIRSPEED CALIBRATION NORMAL STATIC SOURCE

NOTE:

1. Indicated airspeed assumes zero instrument error.
2. The following calibrations are not valid in the pre-stall buffet.
3. The following calibrations are valid for the pilot's and copilot's airspeed indicators when the standard or optional dual static system is installed.

Gear Up Flaps 0°		Gear Down Flaps 15°		Gear Down Flaps 35°	
IAS	KCAS	IAS	KCAS	IAS	KCAS
70	71	70	72	70	71
80	81	80	82	80	81
90	91	90	92	90	91
--	--	--	--	93 *	94 *
100	101	100	102	100	101
110	111	110	112	110	111
120	121	120	122	120	121
140	142	130	132	130	131
160	162	140	142	139	140
180	182	150	152	---	---
200	202	158	160	---	---
220	223	---	---	---	---
223	227	---	---	---	---

*Recommended Minimum All Engines Approach Speed with 35° Flaps.

Figure 5-1

AIRSPEED CALIBRATION ALTERNATE STATIC SOURCE

NOTE:

1. Indicated airspeed assumes zero instrument error.
2. The following calibrations are not valid in the prestall buffet.
3. The following calibrations are valid for pilot's and copilot's airspeed indicators when the standard static system is installed.
4. An alternate static source is not approved for copilot's instruments when optional dual static system is installed.

PILOTS FOUL WEATHER WINDOW CLOSED

Gear Up Flaps 0°		Gear Down Flaps 15°		Gear Down Flaps 35°	
KIAS	KCAS	KIAS	KCAS	KIAS	KCAS
---	---	70	69	70	70
80	80	80	78	80	80
90	90	90	88	90	89
--	--	--	--	96 *	94 *
100	99	100	98	100	98
110	109	110	107	110	107
120	118	120	117	120	117
140	137	130	127	130	126
160	156	140	136	140	135
180	175	150	146	145	140
200	195	160	156	---	---
220	214	165	160	---	---
234	227	---	---	---	---

PILOTS FOUL WEATHER WINDOW OPENED

---	---	70	59	70	57
80	69	80	69	80	67
90	78	90	78	90	76
100	88	100	88	100	86
---	---	---	---	109 *	94 *
110	97	110	97	110	95
120	107	120	107	120	105
140	125	130	116	130	114
160	145	140	126	140	123
180	163	150	135	158	140
200	182	160	145	---	---
227	201	176	160	---	---
248	227	---	---	---	---

*Recommended Minimum All Engines Approach Speed With 35° Flaps.

Figure 5-2

ALTIMETER CORRECTION NORMAL STATIC SOURCE

NOTE:

1. Add correction to indicated altimeter reading.
2. The following calibrations are valid for the pilot's and copilot's altimeters when the standard or optional dual static system is installed.

Altitude	Sea Level			10,000 Feet			20,000 Feet			
	Gear	Up	Down	Down	Up	Down	Down	Up	Down	Down
Flaps	0°	15°	35°	0°	15°	35°	0°	15°	35°	
KIAS	Feet	Feet	Feet	Feet	Feet	Feet	Feet	Feet	Feet	Feet
80	6	14	7	8	19	9	11	26	13	
93 *	7	15	7	10	21	10	14	29	14	
100	8	19	8	11	26	11	15	35	15	
120	10	23	10	14	32	14	19	44	19	
140	17	27	13	23	37	19	32	50	25	
160	30	30	--	42	41	--	57	55	--	
180	37	--	--	51	--	--	69	--	--	
200	40	--	--	56	--	--	76	--	--	
220	67	--	--	93	--	--	126	--	--	

*Recommended Minimum All Engines Approach Speed With 35° Flaps

ALTITUDE CORRECTION PROCEDURE

$$\left[\begin{array}{c} \text{INDICATED ALTITUDE} \\ \text{TO FLY} \end{array} \right] = \left[\begin{array}{c} \text{DESIRED ALTITUDE} \\ \text{(MSL)} \end{array} \right] - \left[\begin{array}{c} \text{ALTIMETER} \\ \text{CORRECTION} \end{array} \right]$$

Figure 5-3

ALTIMETER CORRECTION ALTERNATE STATIC SOURCE

NOTE:

1. Add correction to indicated altimeter reading.
2. The following calibrations are valid for pilot's and copilot's altimeters when the standard static system is installed.
3. An alternate static source is not available for copilot's instruments when the optional dual static system is installed.

PILOTS FOUL WEATHER WINDOW CLOSED

Altitude	Sea Level			10,000 Feet			20,000 Feet		
	Up	Down	Down	Up	Down	Down	Up	Down	Down
Flaps	0°	15°	35°	0°	15°	35°	0°	15°	35°
CIAS	Feet	Feet	Feet	Feet	Feet	Feet	Feet	Feet	Feet
80	0	-13	-4	0	-19	-6	0	-25	-8
96 *	-8	-19	-15	-11	-23	-23	-15	-32	-32
100	-8	-23	-18	-11	-32	-25	-15	-44	-34
120	-20	-34	-34	-28	-46	-46	-38	-63	-63
140	-34	-45	-57	-46	-62	-79	-63	-84	-107
160	-50	-59	----	-69	-81	----	-95	-111	----
180	-74	----	----	-102	----	----	-139	----	----
200	-94	----	----	-130	----	----	-176	----	----
220	-114	----	----	-157	----	----	-214	----	----

PILOTS FOUL WEATHER WINDOW OPEN

80	-69	-70	-86	-95	-97	-118	-130	-132	-161
100	-94	-94	-114	-130	-130	-157	-176	-176	-214
109 *	-109	-114	-134	-157	-157	-180	-214	-214	-246
120	-131	-131	-151	-180	-180	-208	-246	-246	-286
140	-174	-168	-194	-241	-231	-268	-328	-315	-365
160	-208	-207	----	-287	-287	----	-391	-391	----
180	-258	----	----	-356	----	----	-485	----	----
200	-304	----	----	-420	----	----	-572	----	----
220	-355	----	----	-490	----	----	-668	----	----

*Recommended Minimum All Engines Approach Speed with 35° Flaps.

ALTITUDE CORRECTION PROCEDURE

$$\left[\begin{array}{c} \text{INDICATED ALTITUDE} \\ \text{TO FLY} \end{array} \right] = \left[\begin{array}{c} \text{DESIRED ALTITUDE} \\ \text{(MSL)} \end{array} \right] - \left[\begin{array}{c} \text{ALTIMETER} \\ \text{CORRECTION} \end{array} \right]$$

Figure 5-4

TEMPERATURE RISE DUE TO RAM RECOVERY

NOTE:

1. Subtract temperature rise from indicated outside air temperature to obtain true outside air temperature

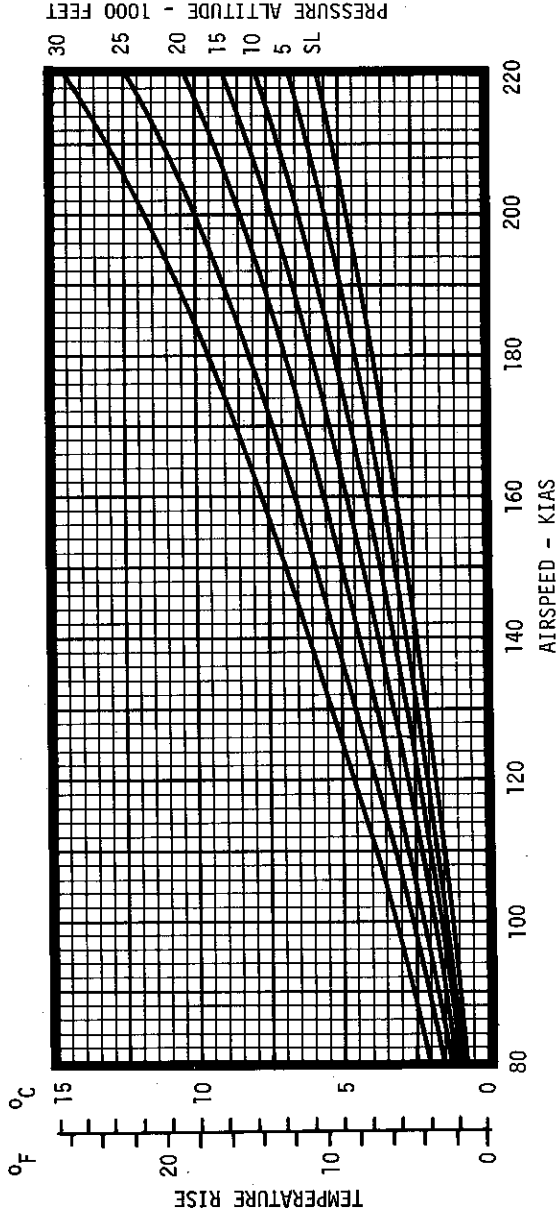
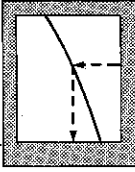

Figure 5-5

TEMPERATURE CONVERSION FROM FAHRENHEIT TO CELSIUS

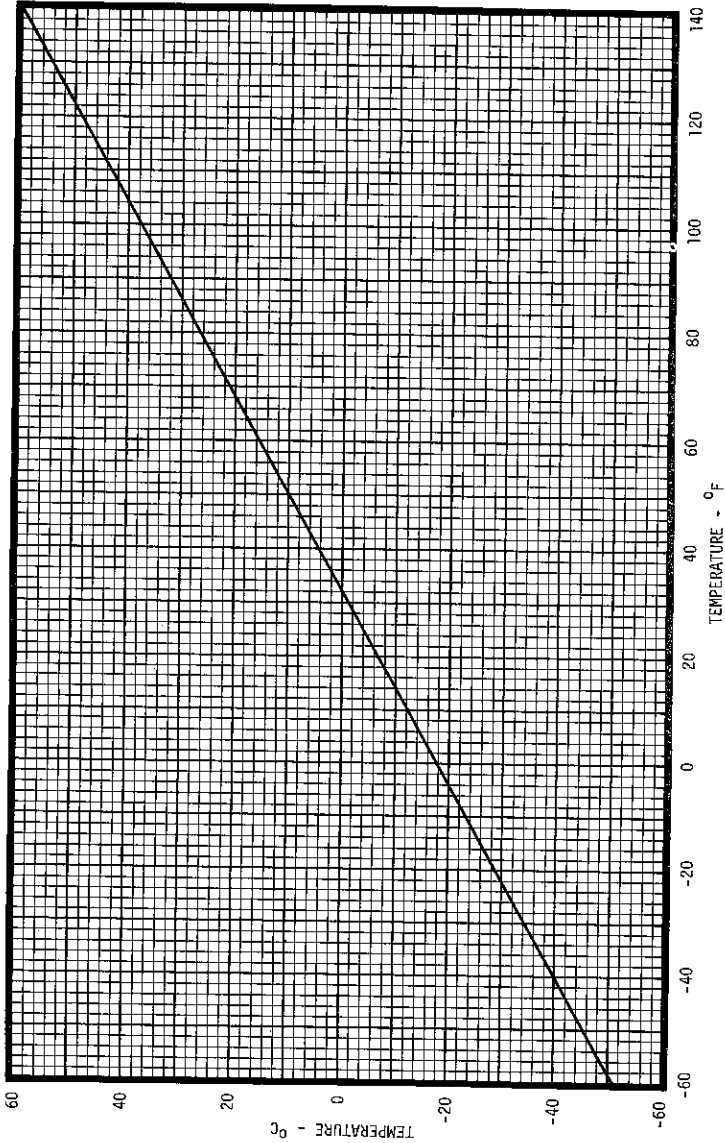
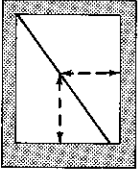

Figure 5-6

PRESSURE CONVERSION INCHES OF MERCURY TO MILLIBARS

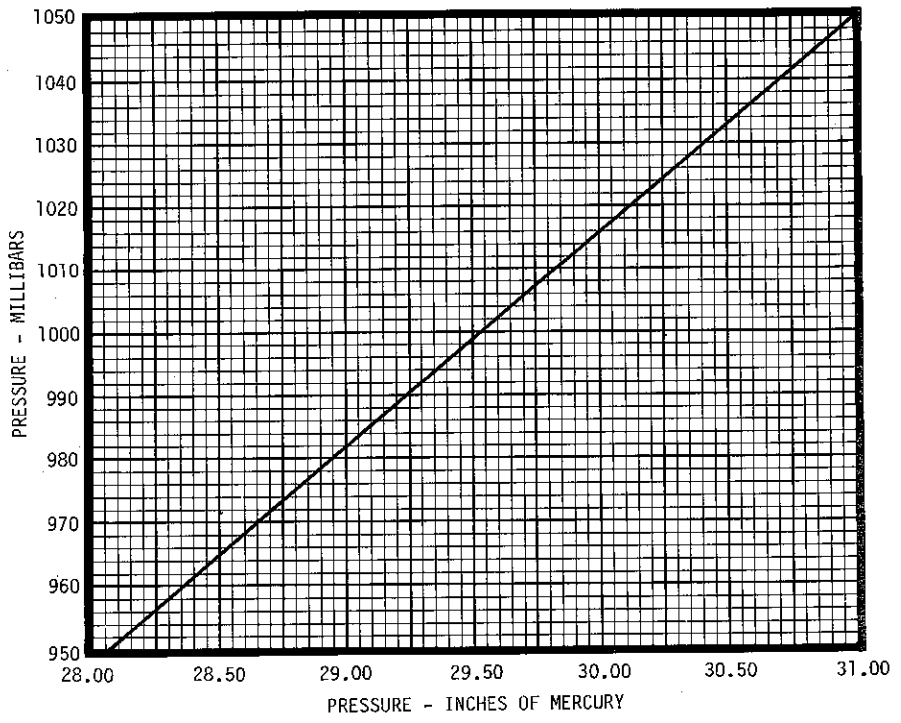
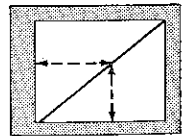

Figure 5-7

STALL SPEEDS

CONDITIONS:

Throttles - IDLE

NOTE:

1. Maximum altitude lost during a stall is 300 feet.
2. Maximum pitch in power-off stall is 10°.

WEIGHT Pounds	Configuration		ANGLE OF BANK							
			0°		20°		40°		60°	
	Flaps	Gear	KIAS	KCAS	KIAS	KCAS	KIAS	KCAS	KIAS	KCAS
5500	0°	Up	79	78	82	81	91	90	112	111
	15°	Down	77	76	79	78	88	87	109	108
	35°	Down	72	70	74	72	82	80	101	99
5100	0°	Up	76	75	79	78	87	86	108	107
	15°	Down	74	73	77	76	85	84	105	104
	35°	Down	69	67	72	70	79	77	97	95
4700	0°	Up	73	72	76	75	84	83	103	102
	15°	Down	71	70	74	73	81	80	100	99
	35°	Down	67	65	69	67	76	74	94	92
4300	0°	Up	70	69	72	71	80	79	99	98
	15°	Down	68	67	70	69	78	77	96	95
	35°	Down	64	62	66	64	73	71	90	88

Figure 5-8

WIND COMPONENT

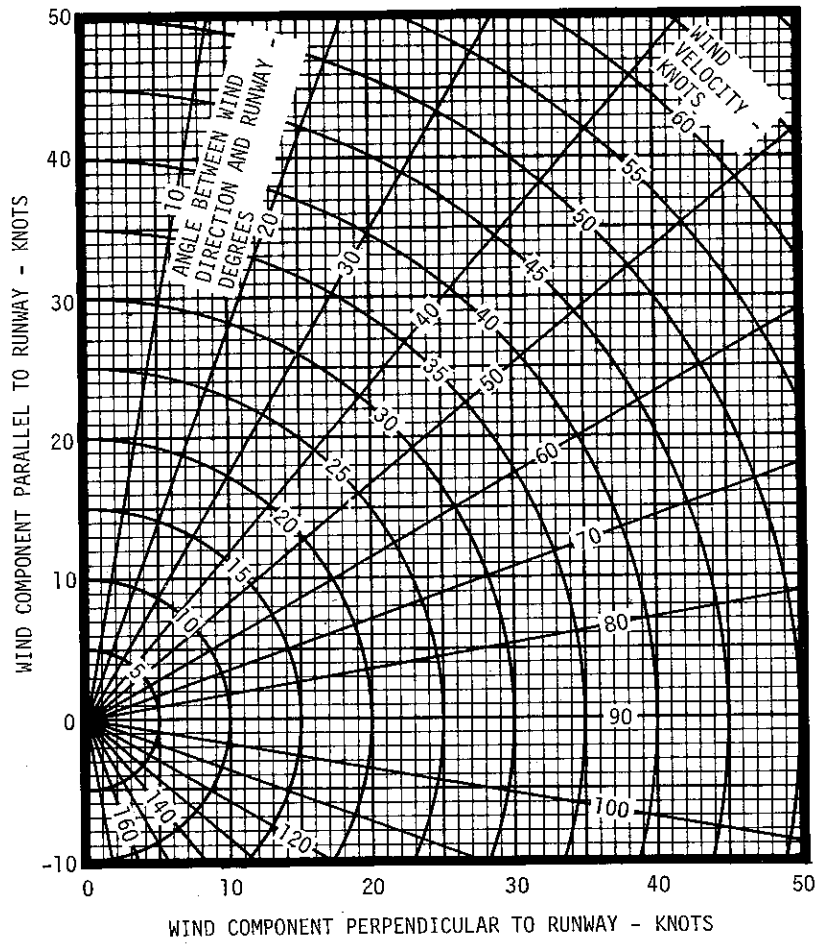
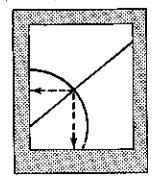

Figure 5-9

NORMAL TAKEOFF DISTANCE

CONDITIONS:

1. Power - FULL THROTTLE and 2700 RPM Before Brake Release.
2. Mixtures - LEAN for field elevation (See Figure 5-27).
3. Wing Flaps - UP.
4. Cowl Flaps - OPEN.
5. Level, Hard Surface, Dry Runway.

NOTE:

1. If full power is applied without brakes set, distances apply from point where full power is applied.
2. Decrease distance 7% for each 10 knots headwind.
3. Increase distance 5% for each 2 knots tailwind.
4. Increase total distance 7.9% for operation on firm dry sod runway.

WEIGHT- POUNDS	TAKEOFF TO 50- FOOT OBSTACLE SPEED- KIAS	PRESSURE ALTITUDE- FEET	-20°C (-4°F)		-10°C (14°F)		0°C (32°F)		10°C (50°F)	
			GROUND ROLL - FEET	TOTAL DISTANCE TO CLEAR 50 FEET	GROUND ROLL - FEET	TOTAL DISTANCE TO CLEAR 50 FEET	GROUND ROLL - FEET	TOTAL DISTANCE TO CLEAR 50 FEET	GROUND ROLL - FEET	TOTAL DISTANCE TO CLEAR 50 FEET
			5500	92	Sea Level	1330	1650	1440	1760	1550
1000	1470	1810			1580	1940	1700	2080	1830	2240
2000	1610	1990			1740	2140	1880	2300	2020	2470
3000	1780	2200			1920	2360	2070	2540	2300	2800
4000	1970	2430			2130	2620	2370	2900	2550	3120
5000	2180	2700			2430	2980	2620	3220	2820	3470
6000	2490	3080			2690	3320	2900	3590	3130	3880
7000	2770	3440			2990	3730	3240	4040	3500	4380
8000	3090	3880			3350	4220	3620	4590	3920	5000
9000	3470	4420			3760	4830	4080	5290	4420	5800
10,000	3880	5050			4220	5550	4580	6130	4980	6810
5100	88	Sea Level	1110	1380	1200	1480	1290	1580	1380	1690
		1000	1220	1510	1320	1620	1420	1740	1520	1860
		2000	1340	1660	1450	1780	1560	1910	1680	2040
		3000	1480	1820	1600	1960	1720	2100	1850	2250
		4000	1630	2010	1760	2160	1900	2330	2050	2500
		5000	1800	2220	1940	2390	2100	2570	2330	2840
		6000	1990	2460	2150	2650	2400	2930	2580	3160
		7000	2210	2730	2470	3030	2660	3270	2870	3530
		8000	2540	3140	2750	3400	2970	3680	3210	3980
		9000	2840	3540	3080	3840	3330	4170	3610	4530
		10,000	3170	3990	3440	4340	3730	4730	4040	5160
4700	85	Sea Level	920	1140	990	1220	1060	1300	1140	1390
		1000	1010	1250	1080	1340	1170	1430	1250	1530
		2000	1100	1360	1190	1460	1280	1570	1370	1670
		3000	1210	1500	1310	1600	1410	1720	1510	1840
		4000	1340	1650	1440	1770	1550	1900	1670	2030
		5000	1470	1810	1590	1940	1710	2090	1840	2240
		6000	1620	2000	1750	2150	1890	2310	2030	2480
		7000	1800	2210	1940	2380	2090	2560	2260	2760
		8000	1990	2460	2160	2650	2330	2860	2600	3170
		9000	2230	2750	2490	3060	2690	3300	2900	3560
		10,000	2560	3160	2770	3420	3000	3700	3240	4010
4300	81	Sea Level	750	930	800	1000	860	1060	920	1130
		1000	820	1020	880	1090	940	1160	1010	1240
		2000	890	1110	960	1190	1030	1270	1110	1360
		3000	980	1210	1050	1300	1130	1390	1220	1490
		4000	1080	1330	1160	1430	1250	1530	1340	1630
		5000	1180	1460	1270	1560	1370	1680	1470	1790
		6000	1300	1600	1400	1720	1510	1840	1620	1980
		7000	1440	1770	1550	1900	1670	2040	1800	2190
		8000	1590	1960	1720	2100	1850	2260	2000	2430
		9000	1770	2180	1910	2340	2060	2530	2230	2720
		10,000	1960	2420	2120	2610	2290	2810	2560	3120

Figure 5-10 (Sheet 1 of 2)

NORMAL TAKEOFF DISTANCE

CONDITIONS:

1. Power - FULL THROTTLE and 2700 RPM Before Brake Release.
2. Mixtures - LEAN for field elevation (See Figure 5-27).
3. Wing Flaps - UP.
4. Cowl Flaps - OPEN.
5. Level, Hard Surface, Dry Runway.

NOTE:

1. If full power is applied without brakes set, distances apply from point where full power is applied.
2. Decrease distance 7% for each 10 knots headwind.
3. Increase distance 5% for each 2 knots tailwind.
4. Increase total distance 7.9% for operation on firm dry sod runway.

WEIGHT- POUNDS	TAKEOFF TO 50- FOOT OBSTACLE SPEED- KIAS	PRESSURE ALTITUDE- FEET	20°C (68°F)		30°C (86°F)		40°C (104°F)	
			GROUND ROLL - FEET	TOTAL DISTANCE TO CLEAR 50 FEET	GROUND ROLL - FEET	TOTAL DISTANCE TO CLEAR 50 FEET	GROUND ROLL - FEET	TOTAL DISTANCE TO CLEAR 50 FEET
			5500	92	Sea Level	1780	2170	1910
		1000	1970	2400	2110	2570	2330	2820
		2000	2240	2710	2400	2910	2570	3120
		3000	2470	3010	2650	3230	2850	3470
		4000	2740	3360	2950	3610	3170	3890
		5000	3040	3740	3270	4040	3520	4360
		6000	3380	4200	3650	4550	3930	4940
		7000	3780	4760	4080	5180	4410	5650
		8000	4240	5470	4590	5990	4970	6600
		9000	4790	6400	5200	7110	5640	7990
		10,000	5410	7640	5880	8720	6390	10,270
5100	88	Sea Level	1480	1800	1590	1930	1700	2060
		1000	1640	1990	1750	2130	1880	2270
		2000	1800	2190	1930	2340	2070	2510
		3000	1990	2420	2130	2590	2360	2850
		4000	2270	2750	2440	2950	2620	3170
		5000	2510	3050	2700	3280	2900	3530
		6000	2780	3400	2990	3660	3220	3950
		7000	3100	3810	3340	4120	3600	4450
		8000	3470	4310	3740	4670	4040	5080
		9000	3900	4930	4220	5370	4560	5880
		10,000	4380	5650	4750	6210	5140	6870
4700	85	Sea Level	1220	1490	1310	1590	1400	1690
		1000	1340	1630	1440	1740	1540	1860
		2000	1470	1790	1580	1910	1690	2040
		3000	1620	1970	1740	2110	1870	2260
		4000	1790	2180	1920	2330	2070	2500
		5000	1980	2400	2130	2580	2350	2840
		6000	2190	2670	2430	2940	2610	3150
		7000	2510	3050	2700	3280	2900	3530
		8000	2800	3410	3010	3680	3240	3970
		9000	3130	3850	3380	4170	3650	4510
		10,000	3500	4350	3780	4720	4090	5130
4300	81	Sea Level	990	1210	1060	1290	1130	1370
		1000	1080	1320	1160	1410	1240	1500
		2000	1190	1450	1270	1540	1360	1650
		3000	1300	1590	1400	1700	1500	1810
		4000	1440	1750	1540	1870	1650	2000
		5000	1580	1920	1700	2060	1820	2200
		6000	1750	2120	1880	2270	2010	2430
		7000	1930	2350	2080	2520	2300	2770
		8000	2150	2620	2390	2880	2560	3100
		9000	2480	3010	2670	3240	2870	3480
		10,000	2760	3360	2970	3620	3200	3910

Figure 5-10 (Sheet 2 of 2)

MAXIMUM PERFORMANCE TAKEOFF DISTANCE

CONDITIONS:

1. Power - FULL THROTTLE and 2700 RPM Before Brake Release.
2. Mixtures - LEAN for field elevation (See Figure 5-27).
3. Wing Flaps - DOWN 15°.
4. Cowl Flaps - OPEN.
5. Level, Hard Surface, Dry Runway.

NOTE:

1. If full power is applied without brakes set, distances apply from point where full power is applied.
2. Decrease distance 3% for each 4 knots headwind.
3. Increase distance 5% for each 2 knots tailwind.
4. Increase total distance 7.9% for operation on firm dry sod runway.

WEIGHT- POUNDS	TAKEOFF TO 50- FOOT OBSTACLE SPEED- KIAS	PRESSURE ALTITUDE- FEET	-20°C (-4°F)		-10°C (14°F)		0°C (32°F)		10°C (50°F)	
			GROUND ROLL - FEET	TOTAL DISTANCE TO CLEAR 50 FEET	GROUND ROLL - FEET	TOTAL DISTANCE TO CLEAR 50 FEET	GROUND ROLL - FEET	TOTAL DISTANCE TO CLEAR 50 FEET	GROUND ROLL - FEET	TOTAL DISTANCE TO CLEAR 50 FEET
5500	82	Sea Level	1040	1340	1120	1440	1200	1540	1290	1650
		1000	1140	1480	1230	1580	1320	1700	1420	1820
		2000	1250	1620	1350	1740	1460	1870	1570	2000
		3000	1380	1780	1490	1920	1610	2060	1730	2210
		4000	1520	1970	1650	2130	1780	2290	1910	2460
		5000	1680	2180	1820	2350	1960	2540	2120	2740
		6000	1860	2420	2010	2620	2170	2830	2350	3060
		7000	2070	2710	2240	2940	2420	3180	2620	3460
		8000	2300	3060	2500	3320	2700	3620	2930	3940
		9000	2580	3480	2800	3800	3040	4160	3410	4690
		10,000	2880	3970	3140	4370	3530	4950	3830	5490
5100	78	Sea Level	870	1130	940	1210	1010	1290	1080	1380
		1000	960	1240	1030	1320	1110	1420	1190	1520
		2000	1050	1350	1130	1450	1210	1550	1310	1660
		3000	1150	1490	1240	1590	1340	1710	1440	1830
		4000	1270	1640	1370	1760	1480	1890	1590	2030
		5000	1400	1800	1510	1940	1630	2090	1750	2240
		6000	1540	1990	1670	2150	1800	2310	1940	2490
		7000	1710	2210	1850	2390	2000	2580	2160	2790
		8000	1900	2480	2060	2680	2220	2900	2400	3140
		9000	2120	2790	2300	3030	2490	3280	2700	3570
		10,000	2360	3140	2570	3420	2780	3730	3020	4070
4700	75	Sea Level	720	940	770	1000	830	1070	890	1140
		1000	790	1030	850	1100	910	1170	980	1250
		2000	860	1120	930	1200	1000	1280	1070	1370
		3000	950	1230	1020	1310	1100	1410	1180	1500
		4000	1040	1350	1120	1440	1210	1550	1300	1660
		5000	1140	1480	1230	1590	1330	1700	1430	1820
		6000	1260	1630	1360	1750	1470	1880	1580	2020
		7000	1390	1800	1510	1930	1620	2080	1750	2240
		8000	1550	2000	1670	2150	1810	2320	1950	2500
		9000	1720	2230	1860	2410	2010	2600	2180	2820
		10,000	1910	2490	2070	2700	2240	2920	2430	3170

Figure 5-11 (Sheet 1 of 2)

MAXIMUM PERFORMANCE TAKEOFF DISTANCE

CONDITIONS:

1. Power - FULL THROTTLE and 2700 RPM Before Brake Release.
2. Mixtures - LEAN for field elevation (See Figure 5-27).
3. Wing Flaps - DOWN 15°.
4. Cowl Flaps - OPEN.
5. Level, Hard Surface, Dry Runway.

NOTE:

1. If full power is applied without brakes set, distances apply from point where full power is applied.
2. Decrease distance 7% for each 10 knots headwind.
3. Increase distance 5% for each 2 knots tailwind.
4. Increase total distance 7.9% for operation on firm dry sod runway.

WEIGHT- POUNDS	TAKEOFF TO 50- FOOT OBSTACLE SPEED- KIAS	PRESSURE ALTITUDE- FEET	20°C (68°F)		30°C (86°F)		40°C (104°F)	
			GROUND ROLL - FEET	TOTAL DISTANCE TO CLEAR 50 FEET	GROUND ROLL - FEET	TOTAL DISTANCE TO CLEAR 50 FEET	GROUND ROLL - FEET	TOTAL DISTANCE TO CLEAR 50 FEET
5500	82	Sea Level	1390	1760	1490	1890	1590	2020
		1000	1530	1950	1640	2080	1760	2230
		2000	1680	2150	1810	2300	1940	2470
		3000	1860	2380	2000	2550	2150	2750
		4000	2060	2650	2220	2850	2380	3070
		5000	2280	2950	2460	3190	2640	3450
		6000	2530	3310	2730	3590	2950	3900
		7000	2830	3750	3160	4190	3410	4570
		8000	3280	4420	3540	4840	3830	5330
		9000	3690	5170	4000	5730	4330	6420
		10,000	4150	6140	4500	6980	4880	8130
5100	78	Sea Level	1160	1470	1240	1570	1330	1680
		1000	1280	1620	1370	1730	1470	1850
		2000	1400	1780	1500	1910	1610	2040
		3000	1550	1960	1660	2100	1780	2260
		4000	1710	2180	1840	2340	1970	2510
		5000	1890	2410	2030	2590	2180	2790
		6000	2090	2690	2250	2890	2420	3120
		7000	2330	3010	2510	3250	2700	3520
		8000	2600	3400	2800	3690	3030	4010
		9000	2920	3890	3270	4360	3530	4760
		10,000	3390	4580	3660	5030	3960	5560
4700	75	Sea Level	960	1220	1020	1300	1090	1380
		1000	1050	1340	1120	1430	1200	1520
		2000	1150	1460	1230	1560	1320	1670
		3000	1270	1610	1360	1720	1460	1840
		4000	1400	1770	1500	1900	1610	2030
		5000	1540	1960	1650	2100	1780	2250
		6000	1700	2170	1830	2330	1970	2500
		7000	1890	2410	2030	2590	2190	2790
		8000	2100	2700	2260	2910	2440	3140
		9000	2350	3040	2540	3290	2730	3570
		10,000	2620	3430	2830	3730	3060	4060

Figure 5-11 (Sheet 2 of 2)

ACCELERATE STOP DISTANCE

CONDITIONS:

1. Power - FULL THROTTLE and 2700 RPM Before Brake Release.
2. Mixtures - LEAN for field elevation (See Figure 5-27).
3. Wing Flaps - UP.
4. Cowl Flaps - OPEN.
5. Level, Hard Surface, Dry Runway.
6. Engine Failure at Engine Failure Speed.
7. Idle Power and Heavy Braking After Engine Failure.

NOTE:

1. If full power is applied without brakes set, distances apply from point where full power is applied.
2. Decrease distance 3% for each 4 knots headwind.
3. Increase distance 5% for each 2 knots tailwind.

WEIGHT - POUNDS	ENGINE FAILURE SPEED - KIAS	PRESSURE ALTITUDE - FEET	TOTAL DISTANCE - FEET						
			-20°C -4°F	-10°C +14°F	0°C 32°F	+10°C +50°F	+20°C +68°F	+30°C +86°F	+40°C +104°F
5500	92	Sea Level	3020	3190	3370	3550	3740	3930	4120
		1000	3220	3400	3590	3790	3990	4210	4490
		2000	3430	3630	3830	4050	4340	4570	4820
		3000	3660	3880	4100	4400	4650	4910	5180
		4000	3920	4160	4480	4730	5000	5290	5590
		5000	4200	4530	4810	5090	5390	5700	6030
		6000	4590	4880	5180	5490	5820	6170	6530
		7000	4950	5270	5600	5940	6310	6700	7110
		8000	5360	5710	6070	6460	6870	7310	7780
		9000	5830	6210	6630	7060	7530	8020	8560
		10,000	6330	6770	7230	7720	8250	8810	9420
5100	88	Sea Level	2540	2680	2830	2980	3140	3300	3470
		1000	2710	2860	3020	3180	3350	3530	3710
		2000	2880	3050	3220	3390	3580	3770	3970
		3000	3070	3250	3440	3630	3830	4040	4330
		4000	3290	3480	3680	3900	4190	4420	4660
		5000	3520	3730	3950	4250	4500	4750	5020
		6000	3770	4010	4320	4580	4850	5130	5430
		7000	4060	4390	4660	4950	5240	5560	5890
		8000	4470	4750	5050	5360	5690	6050	6420
		9000	4840	5160	5490	5840	6220	6610	7030
		10,000	5250	5600	5970	6370	6790	7230	7710
4700	85	Sea Level	2110	2230	2350	2470	2600	2740	2870
		1000	2250	2370	2500	2640	2770	2920	3070
		2000	2390	2520	2660	2810	2960	3120	3280
		3000	2540	2690	2840	3000	3160	3340	3510
		4000	2720	2880	3040	3210	3390	3580	3780
		5000	2900	3080	3260	3440	3640	3840	4130
		6000	3110	3300	3500	3700	3910	4210	4450
		7000	3340	3550	3760	3990	4300	4550	4820
		8000	3600	3830	4070	4390	4660	4940	5230
		9000	3900	4230	4490	4770	5070	5380	5710
		10,000	4300	4580	4870	5180	5510	5860	6240
4300	81	Sea Level	1730	1820	1920	2020	2120	2230	2340
		1000	1830	1940	2040	2150	2260	2380	2500
		2000	1950	2060	2170	2290	2410	2530	2660
		3000	2070	2190	2310	2440	2570	2710	2850
		4000	2210	2340	2470	2610	2750	2900	3060
		5000	2360	2500	2640	2790	2950	3110	3280
		6000	2520	2680	2830	2990	3160	3340	3530
		7000	2710	2870	3040	3220	3410	3600	3880
		8000	2910	3090	3280	3470	3680	3970	4200
		9000	3140	3340	3550	3760	4070	4310	4570
		10,000	3390	3610	3830	4150	4410	4680	4970

Figure 5-12

ACCELERATE GO DISTANCE

CONDITIONS:

1. Power - FULL THROTTLE and 2700 RPM Before Brake Release.
2. Mixtures - Lean for field elevation (See Figure 5-27).
3. Wing Flaps - UP.
4. Cowl Flaps - OPEN.
5. Level Hard Surface Dry Runway.
6. Engine Failure At Engine Failure Speed.
7. Propeller Feathered and Landing Gear Retracted During Climb.
8. Maintain Engine Failure Speed Until Clear of Obstacle.

NOTE:

1. If full power is applied without brakes set, distances apply from point where full power is applied.
2. Decrease distance 6% for each 10 knots headwind.
3. Increase distance 2% for each knot of tailwind.
4. Distance in boxes represent rates of climb less than 50 ft/min.

WEIGHT - POUNDS	ENGINE FAILURE - SPEED - KIAS	PRESSURE ALTITUDE - FEET	TOTAL DISTANCE TO CLEAR 50-FOOT OBSTACLE						
			-20°C -4°F	-10°C +14°F	0°C 32°F	+10°C +50°F	+20°C +68°F	+30°C +86°F	+40°C +104°F
			5500	92	Sea Level	2600	2850	3120	3450
		1000	3010	3330	3700	4160	4760	5560	6810
		2000	3530	3970	4520	5250	6370	8080	11,540
		3000	4310	4990	5950	7520	10,350	-----	-----
		4000	5650	7020	9550	15,790	-----	-----	-----
		5000	8470	13,010	-----	-----	-----	-----	-----
		6000	-----	-----	-----	-----	-----	-----	-----
		7000	-----	-----	-----	-----	-----	-----	-----
		8000	-----	-----	-----	-----	-----	-----	-----
		9000	-----	-----	-----	-----	-----	-----	-----
		10,000	-----	-----	-----	-----	-----	-----	-----
5100	88	Sea Level	2030	2190	2360	2560	2780	3030	3320
		1000	2280	2470	2690	2940	3220	3540	3940
		2000	2580	2820	3090	3400	3770	4230	4810
		3000	2960	3270	3630	4060	4600	5330	6430
		4000	3490	3910	4430	5110	6130	7620	10,430
		5000	4200	4820	5680	7030	9280	14,630	-----
		6000	5350	6500	8480	12,550	-----	-----	-----
		7000	7800	11,240	-----	-----	-----	-----	-----
		8000	-----	-----	-----	-----	-----	-----	-----
		9000	-----	-----	-----	-----	-----	-----	-----
		10,000	-----	-----	-----	-----	-----	-----	-----
4700	85	Sea Level	1600	1720	1840	1980	2130	2290	2460
		1000	1780	1910	2060	2210	2390	2580	2800
		2000	1980	2130	2300	2490	2700	2930	3200
		3000	2210	2400	2600	2830	3090	3390	3740
		4000	2510	2730	2990	3280	3620	4030	4540
		5000	2860	3140	3460	3850	4320	4930	5820
		6000	3320	3690	4130	4700	5450	6610	8370
		7000	3960	4500	5200	6190	7820	10,780	-----
		8000	4990	5920	7350	10,020	16,800	-----	-----
		9000	7040	9510	15,370	-----	-----	-----	-----
		10,000	13,110	-----	-----	-----	-----	-----	-----
4300	81	Sea Level	1270	1360	1450	1550	1650	1760	1890
		1000	1400	1500	1600	1710	1830	1960	2100
		2000	1540	1650	1760	1890	2030	2180	2340
		3000	1700	1820	1960	2110	2270	2440	2640
		4000	1890	2040	2190	2370	2560	2770	3020
		5000	2100	2270	2460	2670	2900	3170	3470
		6000	2360	2570	2790	3050	3340	3690	4100
		7000	2690	2940	3220	3550	3950	4430	5110
		8000	3110	3430	3810	4280	4860	5720	6850
		9000	3690	4150	4710	5460	6610	8330	11,760
		10,000	4490	5190	6160	7730	10,510	-----	-----

Figure 5-13

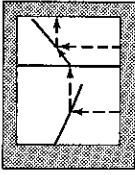

- CONDITIONS:
1. 2700 RPM and Full Throttle.
 2. Landing gear - UP.
 3. Wing Flaps - UP.
 4. Cowl Flaps - OPEN.
 5. Mixture - ADJUST for Altitude and Power (See Figure 5-27).

RATE-OF-CLIMB - MAXIMUM CLIMB

WEIGHT Pounds	CLIMB SPEED - KIAS				
	Sea Level	5000 Feet	10,000 Feet	15,000 Feet	20,000 Feet
5500	107	103	99	95	91
5100	103	99	96	92	88
4700	99	95	92	88	85

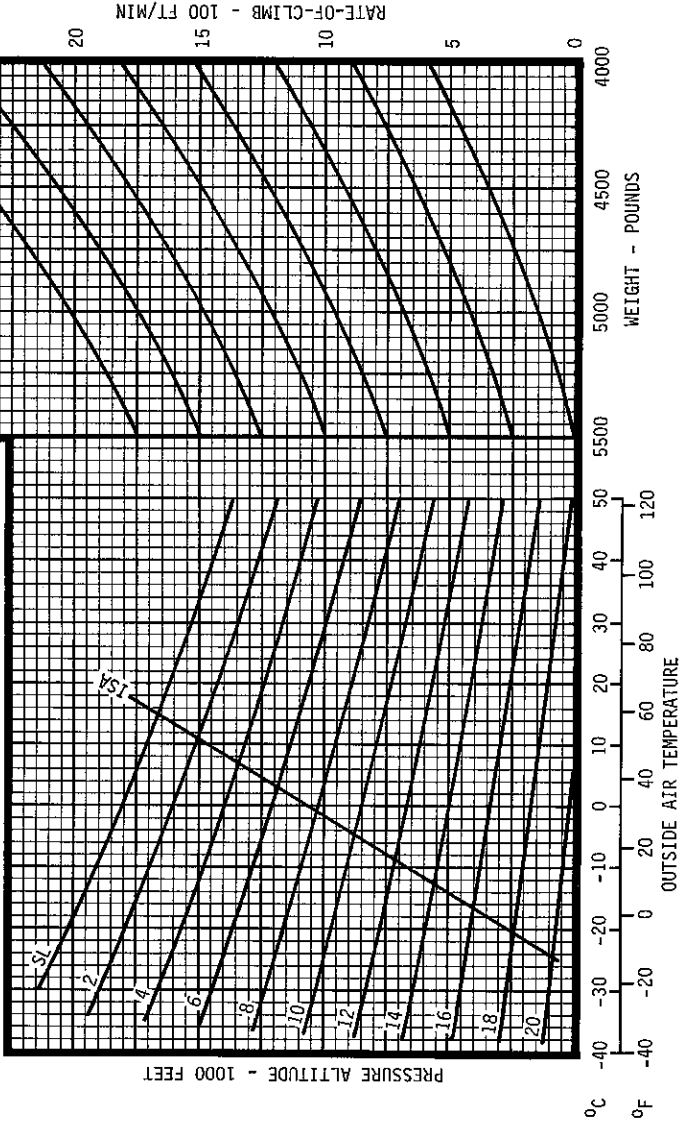

Figure 5-14

RATE-OF-CLIMB - CRUISE CLIMB

CONDITIONS:

1. 2500 RPM and 24.5 Inches Hg.*
2. Landing Gear - UP.
3. Wing Flaps - UP.

4. Cowl Flaps - AS REQUIRED.
5. Airspeed - 120 KIAS.
6. Mixtures - Recommended Fuel Flow.

*Above 5200 feet, use full throttle.

RATE-OF-CLIMB - FT/MIN								
WEIGHT- POUNDS	PRESSURE ALTITUDE- FEET	OUTSIDE AIR TEMPERATURE						
		-20°C (-4°F)	-10°C (14°F)	0°C (32°F)	10°C (50°F)	20°C (68°F)	30°C (86°F)	40°C (104°F)
5500	Sea Level	1101	1034	969	906	844	784	726
	1000	1131	1062	995	930	867	805	744
	2000	1160	1089	1020	953	888	824	762
	3000	1189	1115	1044	976	909	843	779
	4000	1216	1141	1068	997	929	861	796
	5000	1239	1162	1087	1015	944	876	808
	6000	1167	1093	1021	951	883	817	752
	7000	1063	993	925	859	795	732	670
	8000	964	899	835	773	712	652	594
	9000	866	804	744	686	629	573	518
	10,000	770	712	656	601	548	495	443
	11,000	674	621	569	518	468	418	370
	12,000	577	528	480	433	386	340	295
	13,000	487	442	397	354	310	268	226
	14,000	394	353	312	272	232	193	154
	15,000	305	267	230	194	157	121	85
16,000	215	182	148	115	82	49	16	
5100	Sea Level	1264	1189	1116	1046	977	910	844
	1000	1297	1220	1145	1072	1002	933	865
	2000	1329	1250	1173	1098	1025	954	885
	3000	1362	1280	1201	1124	1049	976	905
	4000	1391	1307	1226	1147	1070	996	923
	5000	1419	1333	1250	1169	1090	1014	939
	6000	1337	1254	1174	1096	1020	946	874
	7000	1229	1150	1074	1000	929	858	790
	8000	1121	1047	975	905	837	771	706
	9000	1015	946	878	812	748	686	624
	10,000	910	845	782	720	660	601	543
	11,000	808	747	688	630	574	519	464
	12,000	706	650	595	541	489	437	386
	13,000	607	555	504	455	406	357	310
	14,000	509	461	414	368	323	278	234
	15,000	412	369	326	284	242	200	159
16,000	316	277	238	199	161	123	85	
4700	Sea Level	1449	1364	1283	1204	1127	1052	979
	1000	1485	1398	1314	1233	1154	1077	1002
	2000	1520	1431	1344	1261	1179	1100	1023
	3000	1556	1464	1375	1289	1206	1124	1045
	4000	1587	1492	1401	1313	1228	1145	1064
	5000	1622	1525	1432	1341	1253	1168	1085
	6000	1537	1444	1353	1266	1181	1099	1018
	7000	1425	1336	1250	1167	1086	1008	931
	8000	1315	1231	1149	1070	994	919	846
	9000	1208	1128	1051	977	904	833	763
	10,000	1097	1023	950	880	811	744	678
	11,000	993	923	855	789	724	660	598
	12,000	891	825	761	699	638	578	519
	13,000	791	730	670	611	554	498	443
	14,000	691	634	578	524	470	418	366
	15,000	594	541	490	439	389	340	292
16,000	496	448	400	353	307	262	217	

Figure 5-15

RATE-OF-CLIMB - SINGLE ENGINE

CONDITIONS:

1. 2700 RPM and Full Throttle.
2. Mixture - CHECK Full Power Fuel Flow (See Figure 5-27).
3. Landing Gear - UP.
4. Wing Flaps - UP.
5. Inoperative Propeller - FEATHERED.
6. Wings Banked 5° Toward Operative Engine.
7. Cowl Flaps - CLOSED on Inoperative Engine.

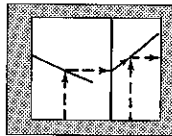

WEIGHT Pounds	CLIMB SPEED - KIAS				
	Sea Level	2500 Feet	5000 Feet	7500 Feet	10,000 Feet
5500	106	103	100	97	94
5100	102	99	96	93	90
4700	98	95	92	89	86

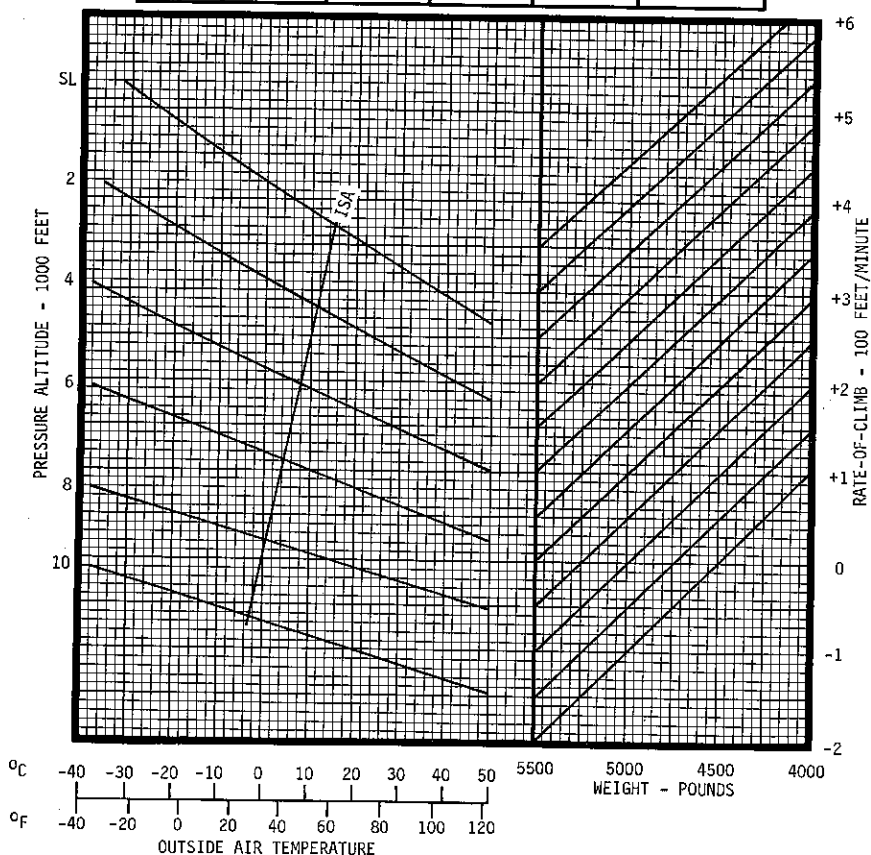
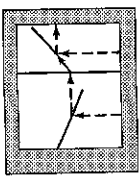

Figure 5-16

RATE-OF-CLIMB - BALKED LANDING CLIMB



- CONDITIONS:**
1. 2700 RPM and Full Throttle.
 2. Mixtures - AS REQUIRED.
 3. Landing Gear - DOWN.
 4. Wing Flaps - 35°.
 5. Cowl Flaps - OPEN.

CLIMB AIRSPEEDS	
PRESSURE ALTITUDE - FEET	AIRSPEED - KIAS
Sea Level	85
5,000	80
10,000	72
12,000	70

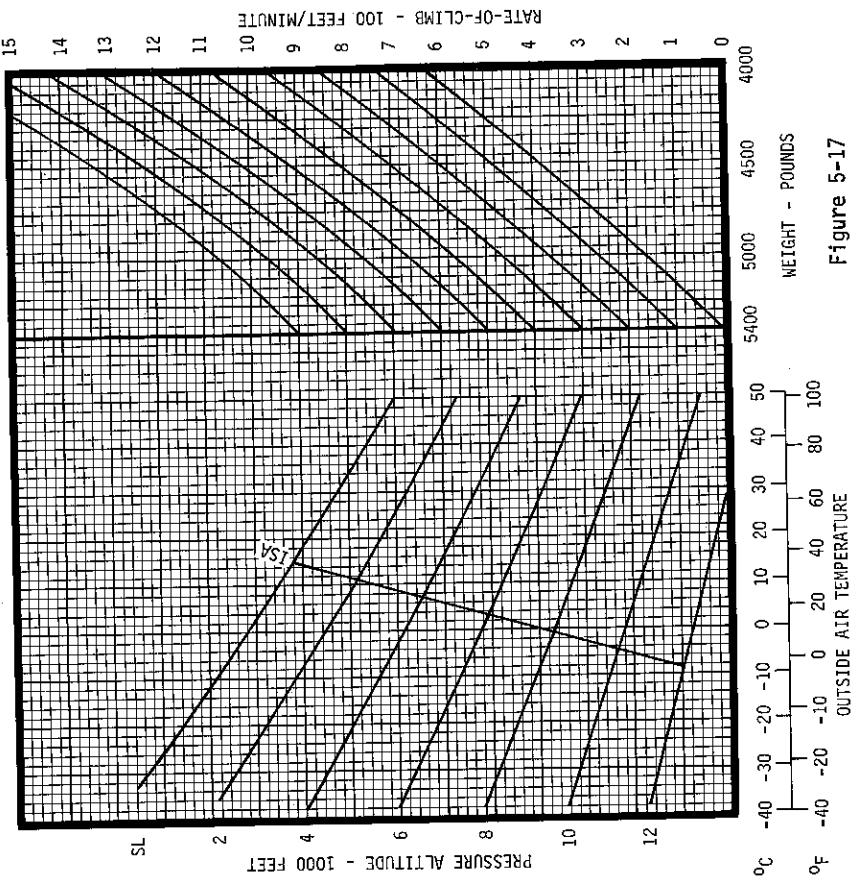
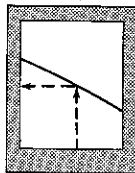

Figure 5-17

SINGLE-ENGINE SERVICE CEILING

CONDITIONS:

1. Single-Engine Climb Configuration.



NOTE:

1. Single-engine service ceiling is the maximum altitude where the airplane has the capability of climbing 50 feet per minute with one engine inoperative and feathered.
2. Increase indicated service ceiling 100 feet for each 0.10 inches Hg. altimeter setting greater than 29.92.
3. Decrease indicated service ceiling 100 feet for each 0.10 inches Hg. altimeter setting less than 29.92.
4. This chart provides performance information to aid in route selection when operating under FAR 135.145 and 91.119 requirements.

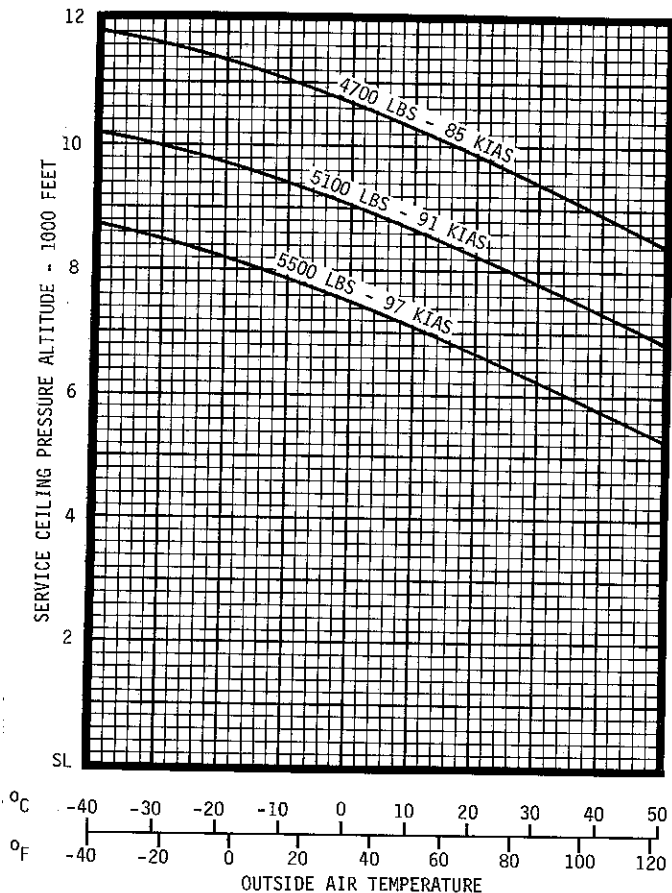
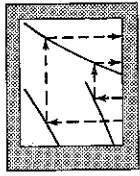
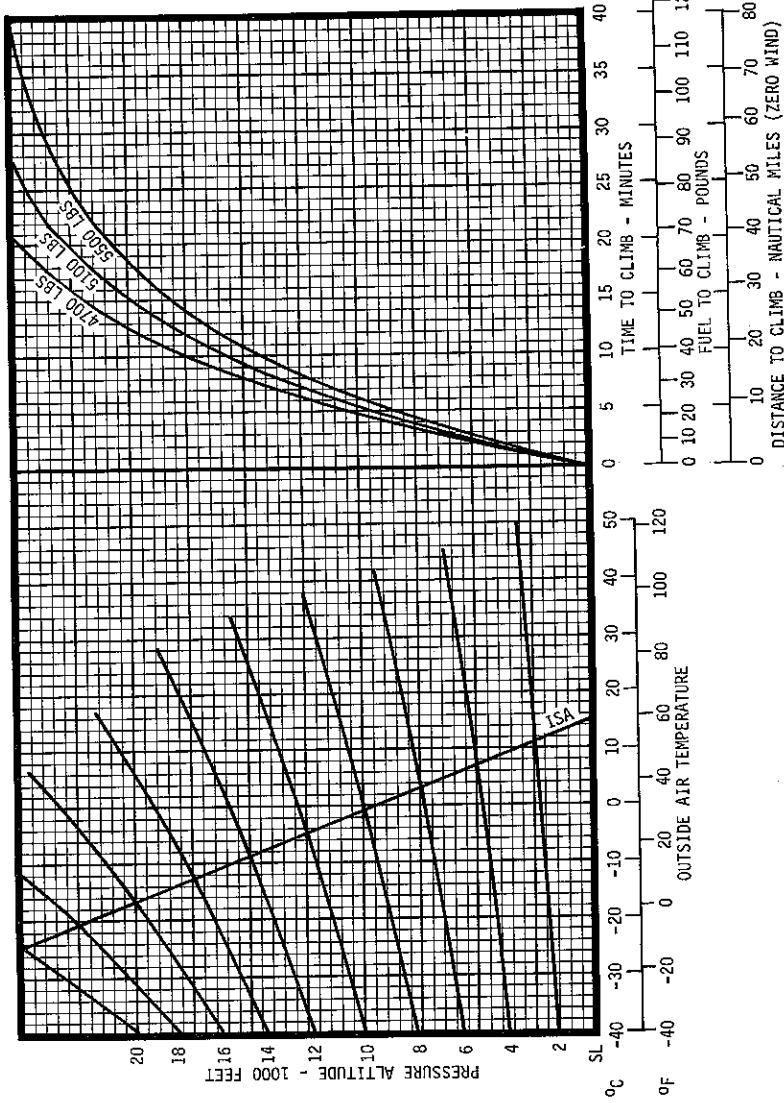

Figure 5-18



TIME, FUEL AND DISTANCE TO CLIMB - MAXIMUM CLIMB



CONDITIONS:

1. Power - 2700 RPM and Full Throttle.
2. Landing Gear - UP.
3. Wing Flaps - UP.
4. Cowl Flaps - OPEN
5. Mixture - ADJUST for altitude and power (See Figure 5-27).

NOTE:

1. Time, fuel and distance for the climb are determined by taking the difference between the airport altitude and initial cruise altitude conditions.
2. For total fuel used, add 25 pounds for start, taxi and takeoff

Figure 5-19

TIME, FUEL AND DISTANCE TO CLIMB - CRUISE CLIMB

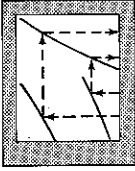

CONDITIONS:

1. 2500 RPM and 24.5 Inches Hg. *
2. Landing Gear - UP.
3. Wing Flaps - UP.
4. Cowl Flaps - AS REQUIRED.
5. Airspeed - 120 KIAS.
6. Fuel Flow - Adjust to climb fuel flow (See Figure 5-27).

*Above 5200 Feet, Use Full Throttle.

NOTE:

1. Time, fuel and distance for the climb are determined by taking the difference between the airport altitude and initial cruise altitude conditions.
2. For total fuel used, add 25 pounds for start, taxi and takeoff.

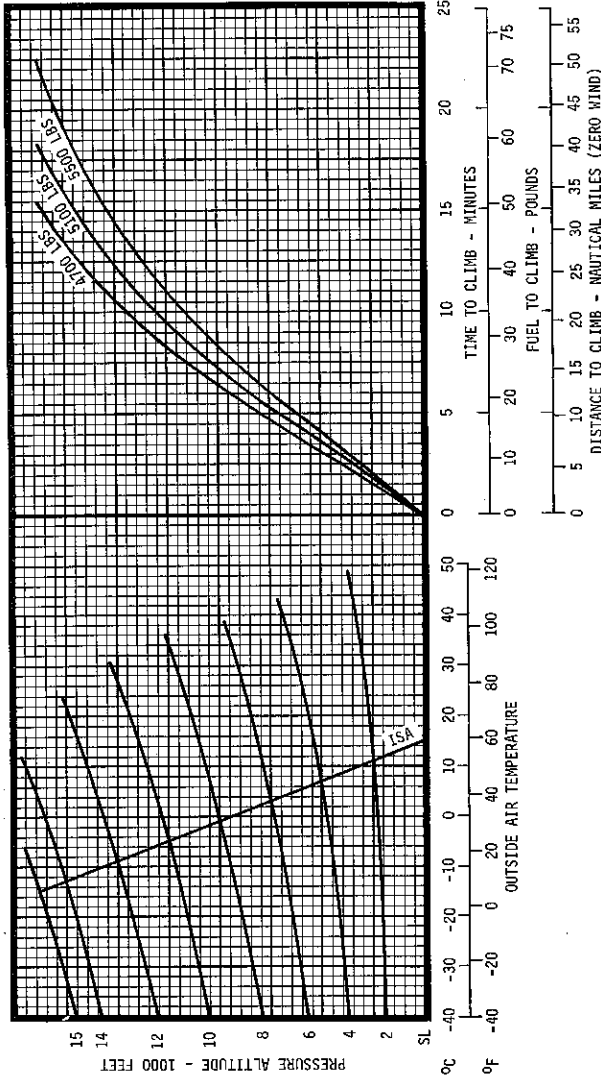

Figure 5-20

CRUISE PERFORMANCE WITH RECOMMENDED LEAN MIXTURE

NOTE:

1. At 2500 feet, increase speed by 2 KTAS for each 400 pounds below 5500 pounds.
2. At 5000 feet, increase speed by 2 KTAS for each 400 pounds below 5500 pounds.
3. Operations at peak EGT may be utilized with power settings within the boxes if the airplane is equipped with the optional EGT system.

ALTITUDE	RPM	MP	-10°C (14°F)			10°C (STD TEMP) (50°F)			30°C (86°F)		
			PERCENT BHP	KTAS	TOTAL LB/HR	PERCENT BHP	KTAS	TOTAL LB/HR	PERCENT BHP	KTAS	TOTAL LB/HR
2500 FEET	2500	24.5	76.5	181	191	73.8	182	185	71.1	184	179
	2500	23.0	69.9	175	176	67.4	176	170	65.0	177	164
	2500	22.0	65.8	171	166	63.5	172	161	61.1	172	156
	2500	21.0	61.5	166	156	59.3	167	152	57.2	167	147
	2400	24.5	73.3	178	184	70.7	179	178	68.1	180	171
	2400	23.0	67.1	172	169	64.8	173	164	62.4	174	158
	2400	22.0	63.1	168	160	60.9	169	155	58.7	169	150
	2400	21.0	59.2	163	151	57.1	164	147	55.0	164	142
	2300	24.5	68.3	173	172	65.9	174	166	63.5	175	161
	2300	23.0	62.7	167	159	60.5	168	154	58.3	169	149
	2300	22.0	59.1	163	151	57.0	164	146	54.9	164	142
	2300	21.0	55.3	158	143	53.4	159	138	51.4	159	133
	2200	24.5	63.9	169	162	61.7	170	157	59.4	170	152
	2200	23.0	58.7	163	150	56.7	163	146	54.6	163	141
	2200	22.0	55.4	158	143	53.4	159	138	51.5	159	134
	2200	21.0	51.9	154	135	50.1	154	130	48.2	153	126
	2200	20.0	48.4	149	126	46.7	148	122	45.0	147	118
	2100	24.5	58.7	163	150	56.7	163	146	54.6	163	141
	2100	23.0	53.8	156	139	51.9	157	135	50.0	156	130
	2100	22.0	50.6	152	131	48.8	152	127	47.0	151	123
	2100	21.0	47.2	146	123	45.5	146	119	43.9	144	115
2100	20.0	44.0	141	116	42.4	140	112	40.9	138	108	
2100	19.0	40.8	134	108	39.4	133	105	37.9	130	101	
			-15°C (5°F)			5°C (STD TEMP) (41°F)			25°C (77°F)		
5000 FEET	2500	24.5	80.7	188	201	77.8	190	194	75.0	192	188
	2500	23.0	73.5	182	185	70.9	184	178	68.4	185	172
	2500	22.0	69.1	178	174	66.7	179	168	64.2	180	162
	2500	21.0	64.5	173	163	62.3	174	158	60.0	174	153
	2400	24.5	76.9	185	192	74.2	187	186	71.5	188	180
	2400	23.0	70.4	179	177	67.9	181	171	65.4	181	165
	2400	22.0	66.1	175	167	63.8	176	161	61.5	176	156
	2400	21.0	62.0	170	157	59.8	171	153	57.7	171	148
	2300	24.5	71.4	180	179	68.9	182	173	66.4	182	167
	2300	23.0	65.5	174	165	63.2	175	160	60.9	176	155
	2300	22.0	61.9	170	157	59.7	171	152	57.5	171	147
	2300	21.0	57.8	165	148	55.8	165	144	53.7	165	139
	2200	24.5	66.5	175	168	64.2	176	162	61.8	177	157
	2200	23.0	61.2	169	156	59.0	170	151	56.9	170	146
	2200	22.0	57.8	165	148	55.8	165	144	53.7	165	139
	2200	21.0	54.3	160	140	52.4	160	136	50.5	160	131
	2200	20.0	50.7	155	132	48.9	154	127	47.2	153	123
	2100	24.5	61.0	169	155	58.8	170	150	56.7	170	146
	2100	23.0	56.2	163	145	54.2	163	140	52.2	163	135
	2100	22.0	53.0	158	137	51.1	158	133	49.2	157	128
	2100	21.0	49.7	153	129	47.9	153	125	46.2	151	121
2100	20.0	46.4	147	121	44.8	146	117	43.1	145	114	
2100	19.0	43.1	141	113	41.6	139	110	40.0	136	106	
2100	18.0	39.9	134	106	38.5	131	102	37.1	126	99	

Figure 5-21 (Sheet 1 of 3)

CRUISE PERFORMANCE WITH RECOMMENDED LEAN MIXTURE

NOTE:

1. At 7500 Feet, increase speed by 3 KTAS for each 400 pounds below 5500 pounds.
2. At 10,000 Feet, increase speed by 4 KIAS for each 400 pounds below 5500 pounds.
3. Operations at peak EGT may be utilized with power settings within the boxes if the airplane is equipped with the optional EGT system.

ALTITUDE	RPM	MP	-20°C (-4°F)			0°C (STD TEMP) (32°F)			20°C (68°F)		
			PERCENT BHP	KTAS	TOTAL LB/HR	PERCENT BHP	KTAS	TOTAL LB/HR	PERCENT BHP	KTAS	TOTAL LB/HR
7500 FEET	2500	23.2	77.9	190	194	75.2	192	188	72.4	194	182
	2500	22.0	72.2	185	181	69.7	187	175	67.1	187	169
	2500	21.0	67.3	180	170	64.9	181	164	62.6	181	159
	2500	20.0	63.0	175	160	60.8	176	155	58.5	176	150
	2400	23.0	73.4	186	184	70.8	188	178	68.2	189	172
	2400	22.0	68.9	182	173	66.5	183	168	64.0	183	162
	2400	21.0	64.7	177	163	62.4	178	158	60.1	178	153
	2400	20.0	60.6	172	154	58.4	172	150	56.3	172	145
	2300	23.0	68.2	181	172	65.8	182	166	63.4	183	160
	2300	22.0	64.4	176	163	62.1	177	158	59.8	178	153
	2300	21.0	60.2	171	153	58.1	172	149	56.0	172	144
	2300	20.0	56.5	166	145	54.5	167	141	52.5	166	136
	2200	23.0	63.4	175	161	61.2	176	156	58.9	176	151
	2200	22.0	60.1	171	153	57.9	172	148	55.8	172	144
	2200	21.0	56.5	166	145	54.5	167	141	52.5	166	136
	2200	20.0	52.8	161	137	50.9	161	132	49.0	159	128
	2200	19.0	49.3	155	128	47.6	154	124	45.9	153	120
	2200	18.0	45.7	148	120	44.1	147	116	42.5	144	112
	2100	22.0	55.3	165	143	53.4	165	138	51.4	164	133
	2100	21.0	52.0	160	135	50.2	159	130	48.3	158	126
	2100	20.0	48.7	154	127	47.0	153	123	45.3	151	119
	2100	19.0	45.3	148	119	43.7	146	115	42.1	143	111
	2100	18.0	42.0	141	111	40.5	138	107	39.0	133	104
				-25°C (-13°F)			-5°C (STD TEMP) (23°F)			15°C (59°F)	
10,000 FEET	2500	21.0	69.9	187	176	67.5	188	170	65.0	189	164
	2500	20.0	65.5	182	165	63.2	183	160	60.9	183	155
	2500	19.0	61.1	176	156	59.0	177	151	56.8	176	146
	2500	18.0	56.8	170	146	54.8	170	142	52.8	169	137
	2500	17.0	52.4	163	136	50.5	163	131	48.7	161	127
	2400	21.0	67.0	184	169	64.7	185	163	62.3	185	158
	2400	20.0	62.9	179	159	60.7	179	155	58.5	179	150
	2400	19.0	58.7	173	150	56.6	173	146	54.6	172	141
	2400	18.0	54.5	167	141	52.5	166	136	50.6	165	131
	2400	17.0	50.2	159	131	48.5	158	126	46.7	157	122
	2300	21.0	62.5	178	158	60.3	179	154	58.1	179	149
	2300	20.0	58.7	173	150	56.7	173	146	54.6	173	141
	2300	19.0	55.0	168	142	53.0	167	137	51.1	166	133
	2300	18.0	51.1	161	133	49.3	160	128	47.5	158	124
	2300	17.0	47.2	153	123	45.5	152	119	43.8	149	115
	2200	21.0	58.4	172	150	56.4	173	145	54.3	172	140
	2200	20.0	54.7	167	141	52.8	167	137	50.8	165	132
	2200	19.0	51.1	161	133	49.3	160	128	47.5	158	124
	2200	18.0	47.5	154	124	45.8	153	120	44.2	150	116
	2200	17.0	43.9	147	115	42.4	144	112	40.8	139	108
	2100	21.0	54.3	166	140	52.4	166	136	50.4	165	131
	2100	20.0	50.9	161	132	49.1	160	128	47.3	158	124
	2100	19.0	47.4	154	124	45.7	153	120	44.0	149	116
	2100	18.0	44.0	147	116	42.4	144	112	40.9	140	108
2100	17.0	40.5	138	107	39.1	133	104	37.6	123	100	

Figure 5-21 (Sheet 2 of 3)

CRUISE PERFORMANCE WITH RECOMMENDED LEAN MIXTURE

NOTE:

1. At 15,000 Feet, increase speed by 4 KTAS for each 400 pounds below 5500 pounds.
2. Operations at peak EGT may be utilized with power settings within the boxes if the airplane is equipped with the optional EGT system.

ALTITUDE	RPM	MP	-35°C (-30°F)			-15°C (STD TEMP) (6°F)			5°C (42°F)		
			PERCENT BHP	KTAS	TOTAL LB/HR	PERCENT BHP	KTAS	TOTAL LB/HR	PERCENT BHP	KTAS	TOTAL LB/HR
15,000 FEET	2500	16.0	52.7	170	137	50.9	168	132	49.0	165	128
	2500	15.0	48.1	160	125	46.4	157	121	44.7	153	117
	2500	14.0	43.4	148	114	41.8	143	110			
	2400	16.0	50.9	166	132	49.1	164	128	47.3	161	124
	2400	15.0	46.4	156	121	44.8	153	118	43.2	147	114
	2400	14.0	42.2	144	111	40.7	138	108	----	----	----
	2300	16.0	47.2	158	123	45.5	155	119	43.9	150	115
	2300	15.0	43.3	147	114	41.7	142	110	----	----	----
	2200	16.0	42.9	146	113	41.4	141	109	----	----	----
	2100	16.0	40.6	139	107	39.2	127	104	----	----	----

Figure 5-21 (Sheet 3 of 3)

RANGE PROFILE

CONDITIONS:

1. Starting Weight - 5500 Pounds.
2. Cruise Climb to Desired Altitude.
3. Recommended Lean Fuel Flow.
4. Zero Wind.
5. Standard Day.

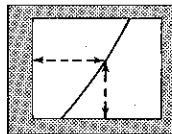

NOTE:

1. Range computations include fuel required for start, taxi, takeoff, cruise climb to altitude, cruise, descent and 45 minutes holding fuel at 45% power.
2. The distances shown are the sum of the distances to climb, cruise and descent.

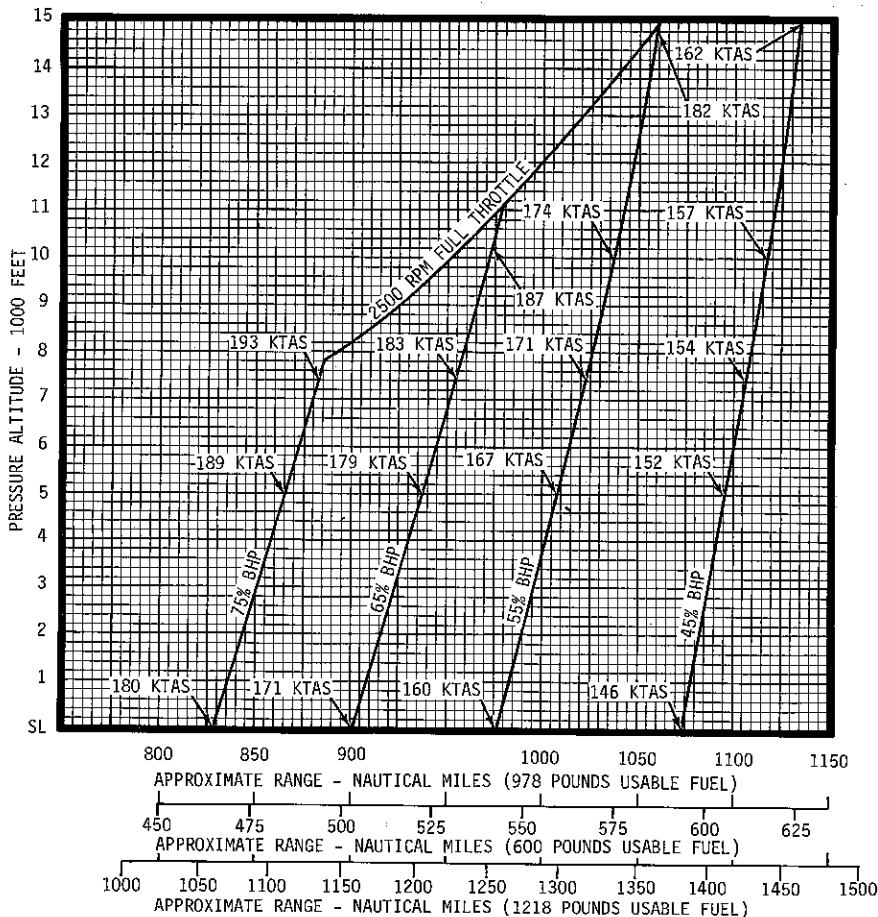
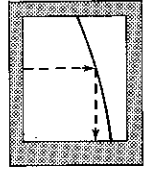

Figure 5-22

ENDURANCE PROFILE

CONDITIONS:

1. Starting Weight - 5500 Pounds.
2. Cruise Climb to Desired Altitude.
3. Cruise Fuel Flow - Recommended Lean Mixture.
4. Standard Day.



NOTE:

1. Endurance computations include fuel required for start, taxi, takeoff, cruise climb to altitude, cruise, descent and 45 minutes holding fuel at 45% power.
2. The endurance shown is the sum of the time to climb, cruise and descend

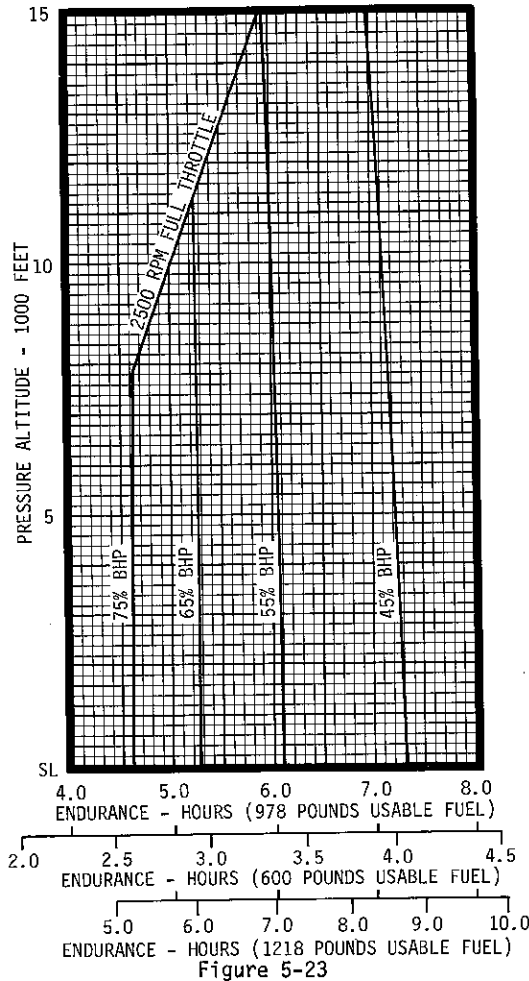

Figure 5-23

HOLDING TIME

CONDITIONS:

1. Power - 45%*
2. Recommended Lean Fuel Flow
(118 Pounds Per Hour Total).

*45% power can be maintained at 2100 RPM with the following manifold pressure.

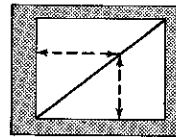

PRESSURE ALTITUDE	MANIFOLD PRESSURE
Sea Level	21.5
5,000	20.0
10,000	19.0
15,000	18.0

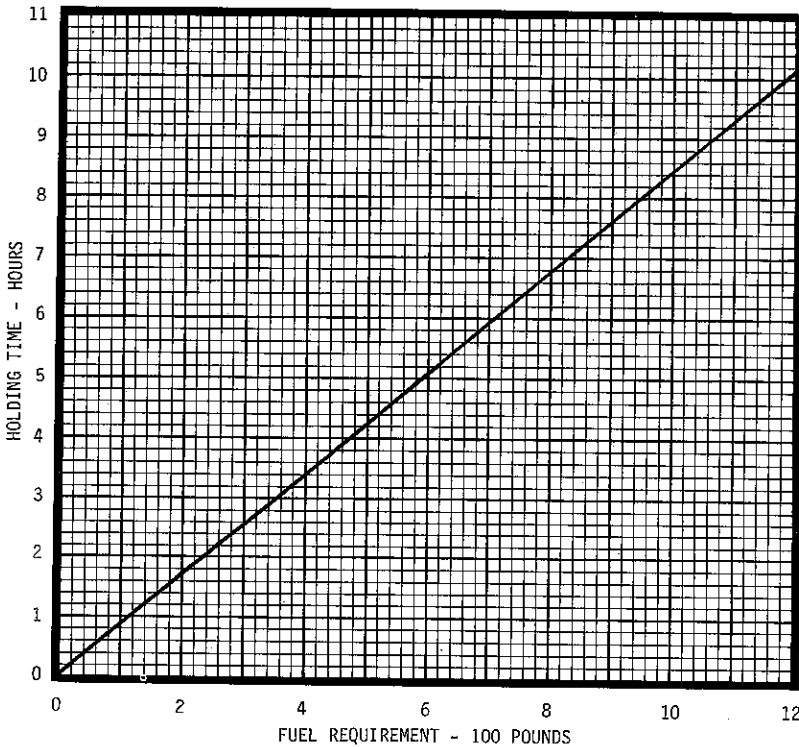

Figure 5-24

TIME, FUEL AND DISTANCE TO DESCEND

CONDITIONS:

1. Power - As Required.
2. Above 10,000 Feet, Descend at 1000 Feet Per Minute.
3. Below 10,000 Feet, Descend at 500 Feet Per Minute.
4. Landing Gear - UP.
5. Wing Flaps - UP.
6. Airspeed - 170 KIAS.

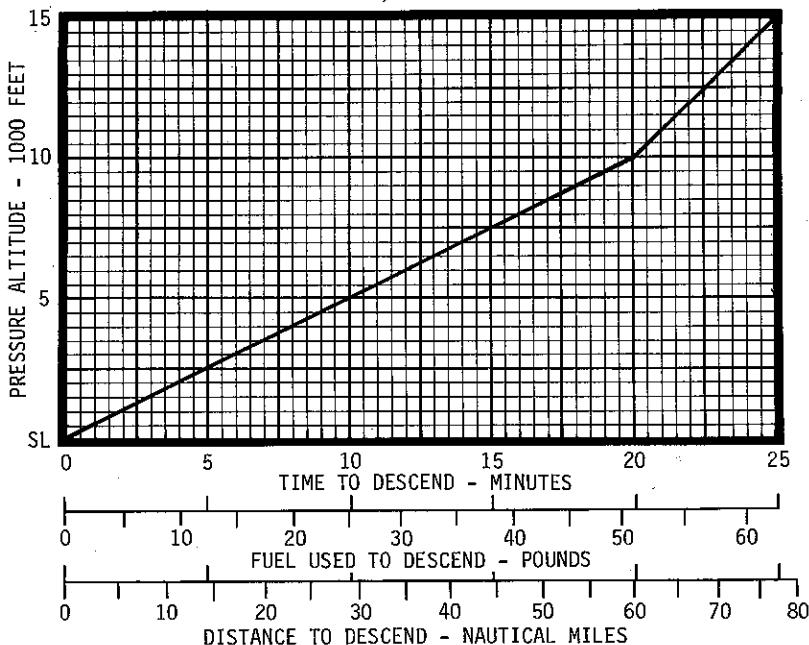
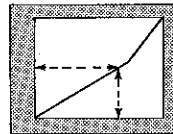

Figure 5-25

NORMAL LANDING DISTANCE

CONDITIONS:

1. Throttles - IDLE.
2. Landing Gear - DOWN.
3. Wing Flaps - 35°
4. Cowl Flaps - CLOSE.
5. Level, Hard Surface Runway.
6. Maximum Braking Effort.

NOTE:

1. Increase distance by 25% of ground run for operation on firm sod runway.
2. If necessary to land with wing flaps UP, the approach speed should be increased above the normal approach speed by 12 knots. Expect total landing distance to increase by 35%.
3. Decrease total distances by 3% for each 4 knots headwind. For operations with tailwinds up to 10 knots, increase total distances by 5% for each 2 knots wind.

WEIGHT-POUNDS	SPEED AT 50-FOOT OBSTACLE KIAS	PRESSURE ALTITUDE - FEET	-20°C (-4°F)		-10°C (14°F)		0°C (32°F)		10°C (50°F)	
			GROUND ROLL - FEET	TOTAL DISTANCE TO CLEAR 50-FOOT OBSTACLE	GROUND ROLL - FEET	TOTAL DISTANCE TO CLEAR 50-FOOT OBSTACLE	GROUND ROLL - FEET	TOTAL DISTANCE TO CLEAR 50-FOOT OBSTACLE	GROUND ROLL - FEET	TOTAL DISTANCE TO CLEAR 50-FOOT OBSTACLE
5400	93	Sea Level	570	1720	590	1740	610	1760	630	1780
		1000	590	1740	610	1760	630	1780	660	1810
		2000	610	1760	630	1780	660	1810	680	1830
		3000	630	1780	660	1810	680	1830	710	1860
		4000	660	1810	680	1830	710	1860	730	1880
		5000	680	1830	710	1860	730	1880	760	1910
		6000	710	1860	730	1880	760	1910	790	1940
		7000	730	1880	760	1910	790	1940	820	1970
		8000	760	1910	790	1940	820	1970	850	2000
		9000	790	1940	820	1970	850	2000	880	2030
10,000	820	1970	850	2000	890	2040	920	2070		
5000	89	Sea Level	480	1630	500	1650	520	1670	540	1690
		1000	500	1650	520	1670	540	1690	560	1710
		2000	520	1670	540	1690	560	1710	580	1730
		3000	530	1680	560	1710	580	1730	600	1750
		4000	550	1700	580	1730	600	1750	620	1770
		5000	580	1730	600	1750	620	1770	640	1790
		6000	600	1750	620	1770	640	1790	670	1820
		7000	620	1770	640	1790	670	1820	690	1840
		8000	640	1790	670	1820	690	1840	720	1870
		9000	670	1820	700	1850	720	1870	750	1900
10,000	700	1850	720	1870	750	1900	780	1930		
4600	86	Sea Level	400	1550	420	1570	430	1580	460	1600
		1000	410	1560	430	1580	450	1600	460	1610
		2000	430	1580	450	1600	460	1610	480	1630
		3000	450	1600	460	1610	480	1630	500	1650
		4000	460	1610	480	1630	500	1650	520	1670
		5000	480	1630	500	1650	520	1670	540	1690
		6000	500	1650	520	1670	540	1690	560	1710
		7000	520	1670	540	1690	560	1710	580	1730
		8000	540	1690	560	1710	580	1730	600	1750
		9000	560	1710	580	1730	600	1750	620	1770
10,000	580	1730	600	1750	620	1770	650	1800		
4200	82	Sea Level	330	1480	340	1490	350	1500	370	1520
		1000	340	1490	350	1500	370	1520	380	1530
		2000	350	1500	370	1520	380	1530	390	1540
		3000	370	1520	380	1530	390	1540	410	1560
		4000	380	1530	390	1540	410	1560	420	1570
		5000	390	1540	410	1560	420	1570	440	1590
		6000	410	1560	420	1570	440	1590	460	1610
		7000	420	1570	440	1590	460	1610	470	1620
		8000	440	1590	460	1610	470	1620	490	1640
		9000	460	1610	480	1630	490	1640	510	1660
10,000	480	1630	490	1640	510	1660	530	1680		

Figure 5-26 (Sheet 1 of 2)

NORMAL LANDING DISTANCE

CONDITIONS:

1. Throttles - IDLE.
2. Landing Gear - DOWN.
3. Wing Flaps - 35°.
4. Cowl Flaps - CLOSE.
5. Level, Hard Surface Runway.
6. Maximum Braking Effort.

NOTE:

1. Increase distance by 25% of ground run for operation on firm sod runway.
2. If necessary to land with wing flaps UP, the approach speed should be increased above the normal approach speed by 12 knots. Expect total landing distance to increase by 35%.
3. Decrease total distances by 3% for each 4 knots headwind. For operations with tailwinds up to 10 knots, increase total distances by 5% for each 2 knots wind.

WEIGHT- POUNDS	SPEED AT 50-FOOT OBSTACLE KIAS	PRESSURE ALTITUDE - FEET	20°C (68°F)		30°C (86°F)		40°C (104°F)	
			GROUND ROLL - FEET	TOTAL DISTANCE TO CLEAR 50-FOOT OBSTACLE	GROUND ROLL - FEET	TOTAL DISTANCE TO CLEAR 50-FOOT OBSTACLE	GROUND ROLL - FEET	TOTAL DISTANCE TO CLEAR 50-FOOT OBSTACLE
5400	93	Sea Level	660	1810	680	1830	700	1850
		1000	680	1830	700	1850	730	1880
		2000	710	1860	730	1880	750	1900
		3000	730	1880	760	1910	780	1930
		4000	760	1910	780	1930	810	1960
		5000	790	1940	810	1960	840	1990
		6000	820	1970	850	2000	870	2020
		7000	850	2000	880	2030	910	2060
		8000	880	2030	910	2060	940	2090
		9000	920	2070	950	2100	980	2130
		10,000	950	2100	980	2130	1020	2170
5000	89	Sea Level	550	1700	570	1720	590	1740
		1000	570	1720	590	1740	610	1760
		2000	600	1750	620	1770	640	1790
		3000	620	1770	640	1790	660	1810
		4000	640	1790	660	1810	680	1830
		5000	670	1820	690	1840	710	1860
		6000	690	1840	710	1860	740	1890
		7000	720	1870	740	1890	770	1920
		8000	750	1900	770	1920	800	1950
		9000	770	1920	800	1950	830	1980
		10,000	800	1950	830	1980	860	2010
4600	86	Sea Level	460	1610	480	1630	490	1640
		1000	480	1630	500	1650	510	1660
		2000	500	1650	510	1660	530	1680
		3000	520	1670	530	1680	550	1700
		4000	530	1680	550	1700	570	1720
		5000	550	1700	570	1720	590	1740
		6000	580	1730	600	1750	610	1760
		7000	600	1750	620	1770	640	1790
		8000	620	1770	640	1790	660	1810
		9000	650	1800	670	1820	690	1840
		10,000	670	1820	690	1840	720	1870
4200	82	Sea Level	380	1530	390	1540	410	1560
		1000	390	1540	410	1560	420	1570
		2000	410	1560	420	1570	440	1590
		3000	420	1570	440	1590	450	1600
		4000	440	1590	450	1600	470	1620
		5000	460	1610	470	1620	490	1640
		6000	470	1620	490	1640	500	1650
		7000	490	1640	510	1660	520	1670
		8000	510	1660	530	1680	540	1690
		9000	530	1680	550	1700	560	1710
		10,000	550	1700	570	1720	590	1740

Figure 5-26 (Sheet 2 of 2)

FUEL FLOW SCHEDULE

FULL POWER FUEL FLOW VERSUS ALTITUDE

Power - FULL THROTTLE and 2700 RPM	
PRESSURE ALTITUDE - FEET	FUEL FLOW - POUNDS/HOUR
Sea Level	147
2000	134
4000	124
6000	116
8000	108
10,000	101
12,000	94
14,000	87
16,000	80

CRUISE CLIMB FUEL FLOW VERSUS ALTITUDE

Power - 24.5 Inches Hg. Manifold Pressure and 2500 RPM to 5200 Feet then FULL THROTTLE and 2500 RPM	
PRESSURE ALTITUDE - FEET	FUEL FLOW - POUNDS/HOUR
Sea Level to 5200	107
6000	103
8000	96
10,000	88
12,000	83
14,000	78
16,000	73

Figure 5-27

SECTION 6

WEIGHT & BALANCE/EQUIPMENT LIST

TABLE OF CONTENTS

	Page		Page
INTRODUCTION	6-1	WEIGHT AND BALANCE	
AIRPLANE WEIGHING		RECORD	6-7
PROCEDURES	6-1	EQUIPMENT LIST	6-7
WEIGHT AND BALANCE		WEIGHT AND BALANCE	
DETERMINATION FOR FLIGHT	6-4	FORM	6-31/6-32

INTRODUCTION

Section 6 of the Pilot's Operating Handbook provides procedures for establishing the airplane's basic empty weight and moment and procedures for determining the weight and balance for flight. This section also describes all items on the Weight and Balance Data sheet which was provided with the airplane as delivered from Cessna Aircraft Company. An equipment list, provided at the end of this section, provides arms and weights of all equipment available for installation on the airplane.

AIRPLANE WEIGHING PROCEDURES

To Establish Basic Empty Weight

The airplane must be weighed in the following configuration.

1. Wing flaps shall be fully retracted and all other control surfaces shall be in neutral.
2. Service engine oil as required to obtain a normal full indication.
3. Check landing gear down and parking brake released.
4. Remove all equipment and items not to be included in basic empty weight.
5. Adjust all seats to the normal operating position.
6. Close all baggage doors, main cabin door and emergency exit window.
7. Clean the airplane inside and out.
8. Remove all snow, ice or water which may be on the airplane.
9. Weigh the airplane in a closed hangar to avoid errors caused by air currents.
10. Defuel the airplane in accordance with the following steps.

WARNING

Conduct all defueling operations at a safe distance from other airplanes and buildings. Fire fighting equipment must be readily available. Attach two ground wires from different points on the airplane to separate approved grounding stakes. The use of two ground wires will prevent ungrounding of the airplane due to accidental disconnecting of either wire.

- a. Turn off all electrical power.
 - b. Turn fuel selectors OFF.
 - c. Remove fuel filler caps and remove as much fuel as possible through the fuel filler by using a defueling pump.
 - d. Drain the remaining fuel through the drain valves into an appropriate container.
 - (1) The main tanks are drained by opening the drain valve on the bottom of each tank. The main tank fuel lines are drained by removing two fuel sump drain valves located on the left wing gap fairing. The right and left fuel selector valves are drained forward of the main spar on the outboard side of each nacelle.
 - (2) Each auxiliary tank is drained through the drain valve located outboard of each nacelle and forward of the rear spar. The wing locker fuel tanks are drained by opening a drain valve located on the lower surface of the wing, inboard of the respective engine nacelle. Each wing locker fuel transfer line is drained by opening the drain valve located in the wing leading edge lower surface outboard of the respective nacelle.
 - (3) Each drain should remain open until the defueling rate slows to approximately 1 drop per second.
 - e. The fuel remaining on-board after defueling is residual fuel and is included in the basic empty weight.
 - f. Drainable unusable fuel must be added after the weighing to obtain basic empty weight. Figure 6-1 includes the weight and arms necessary to add the drainable unusable fuel.
11. The airplane must be level when weighed.
- a. For longitudinal leveling, two bolts are located on the left side of the fuselage at stations 88.9 and 59.1. Unscrew these two bolts approximately 1/4 inch so a spirit level can be placed on them.
 - b. For lateral leveling, use a spirit level on the underside of the fuselage at station 37.5.
12. When weighing on the wheels or jack points with mechanical scales, insure the scales are in calibration and used per the applicable manufacturer's recommendations. When weighing on the wheels, deflate or inflate the gear struts and/or tires until the airplane is level.
13. When weighing on the jack points with electronic weighing scales, attach the electronic weighing cells to the proper mounting adapters to prevent slipping.
- a. Prepare the electronic weighing kit for use by following the manufacturer's instructions provided with the weighing kit. Adjust all jacks simultaneously until the cells are in contact with the jack points. Continue jacking, keeping the airplane level, until the airplane is supported at the jack points only.

CAUTION

Keep the airplane level while jacking to prevent the airplane from slipping off the jacks and damaging the airplane.

14. Determine scale reading, scale drift and tare from all three scales.
15. Lower the airplane and clear the weighing cells as soon as the readings are obtained.
16. Computations (See Figure 6-1).
 - a. Enter the scale reading, scale drift and tare from all three scales in the columns in the Airplane As Weighed Table. Compute and enter values for the Net Weight and Airplane Total As Weighed columns.
 - b. Determine the CG arm of the airplane using the formula presented in Figure 6-1, if the jack points are used for weighing. If the airplane is weighed on the wheels, use the following formula.

$$\text{CG Arm of Airplane As Weighed} = 55.63 - \frac{110.21 W_N}{W_T} = \text{Inches Aft of Datum}$$

where W_N = net weight on nosewheel and W_T = total net weight on all three wheels

- c. Enter the total Net Weight and CG Arm in the Basic Empty Weight and Center of Gravity Table columns. Multiply the Weight (Lbs) entry times the CG Arm (In) entry to determine Moment (In-Lbs/100) entry. Delete printed weight, arm and moments listed for fuel tank configurations not installed in the airplane. Total each of the three columns to determine basic empty weight, CG arm and moment.

NOTE

An attempt should be made to verify the results of each weighing, when data for comparison is available.

- d. Enter Basic Empty Weight, CG arm and moment in the Weight and Balance Record, see Figure 6-4.

WEIGHT AND BALANCE DETERMINATION FOR FLIGHT

The following is a sample weight and balance determination. For an actual determination for your airplane, refer to the equivalent illustrations on the Weight and Balance Data sheet provided in your airplane.

To compute the weight and balance for your airplane, use Figures 6-2 through 6-4 as follows:

Take the Basic Empty Weight and Moment/100 from the latest entry shown on the Weight and Balance Data sheet or in Figure 6-4 and enter them in item 1 (Basic Empty Weight) of Figure 6-3. For this sample, assume a weight of 3472 pounds and moment/100 of 1220.

NOTE

A blank Weight and Balance Form is provided, for the operator's convenience, at the end of this section.

WEIGHT AND MOMENT TABLES

WEIGHT (POUNDS)	BAGGAGE					
	NOSE COMPARTMENT ARM = 31"	WING CENTER ARM = 63"	CABIN COMPARTMENTS			
			ARM = 96"	ARM = 124"	ARM = 126"	
MOMENT/100						
10	-3	6	10	12	13	
20	-6	13	19	25	25	
30	-9	19	29	37	38	
40	-12	25	38	50	50	
50	-16	32	48	62	63	
60	-19	38	58	74	76	
70	-22	44	67	87	88	
80	-25	50	77	99	101	
90	-28	57	86	112	113	
100	-31	63	96	124	126	
110	-34	69	106	136	139	
120	-37	76	115	149	151	
130	-40	82	125	161	164	
140	-43	88	134	174	176	
150	-46	94	144	186	189	
160	-50	101	154	198	202	
170	-53	107	163			
180	-56	113	173			
190	-59	120	182			
200	-62	126	192			
210	-65	132				
220	-68	139				
230	-71	145				
240	-74	151				
250	-78					
260	-81					
270	-84					
280	-87					
290	-90					
300	-93					
310	-96					
320	-99					
330	-102					
340	-105					
350	-108					

WEIGHT (POUNDS)	CREW AND PASSENGERS					
	1ST OR 2ND SEATS ARM = 37"	3RD OR 4TH SEATS		5TH OR 6TH SEAT ARM = 102"		
		BENCH SEAT ARM = 71"	INDIVIDUAL SEAT ARM = 68"			
MOMENT/100						
10	4	7	7	10	20	
20	7	14	14	20	40	
30	11	21	21	31	61	
40	15	28	27	41	81	
50	18	36	34	51	101	
60	22	43	41	61	121	
70	26	50	48	71	141	
80	30	57	54	82	161	
90	33	64	61	92	181	
100	37	71	68	102	201	
110	41	78	75	112	221	
120	44	85	82	122	241	
130	48	92	88	133	261	
140	52	99	95	143	281	
150	56	106	102	153	301	
160	59	114	109	163	321	
170	63	121	116	173	341	
180	67	128	122	184	361	
190	70	135	129	194	381	
200	74	142	136	204	401	
210	78	149	143	214	421	
220	81	156	150	224	441	
230	85	163	156	235	461	
240	89	170	163	245	481	
250	92	178	170	255	501	
260	96	185	177	265	521	
270	100	192	184	275	541	
280	104	199	190	286	561	
290	107	206	197	296	581	
300	111	213	204	306	601	

FUEL					
GALLONS	WEIGHT (POUNDS)	MOMENT/100			
		WING TANKS ARM = 25"	AUXILIARY WING TANKS ARM = 47"	WING LOCKER TANKS ARM = 49"	
5	30	10	14	15	
10	60	21	28	29	
15	90	32	42	44	
20	120	42	56	59	
25	150	52	70	74	
30	180	63	85	88	
35	210	74	99	103	
40	240	84	113	118	
45	270	94	127		
50	300	105	141		
55	330	116	156		
60	360	126	169		
63	378	132	178		
66	390	136			
70	420	147			
75	450	158			
80	480	168			
85	510	178			
90	540	189			
95	570	200			
100	600	210			

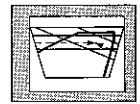
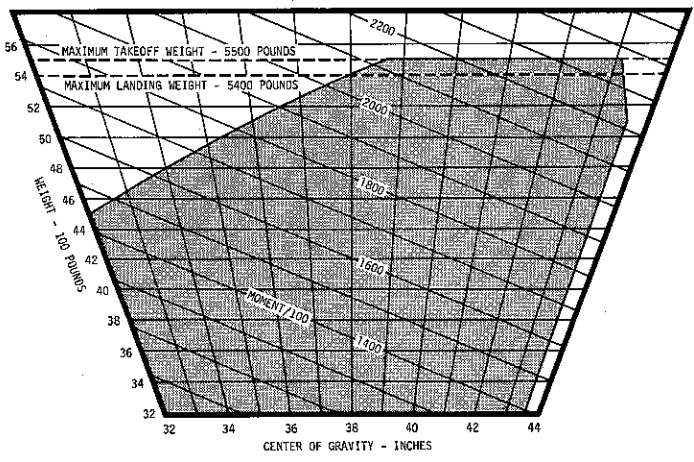
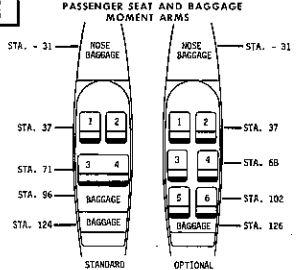

Figure 6-2

SAMPLE WEIGHT AND BALANCE FORM

PAYLOAD COMPUTATIONS				R E F	ITEM	WEIGHT	MOMENT/ 100	
ITEM OCCUPANTS OR CARGO	ARM	WEIGHT	MOMENT/ 100	1.	BASIC EMPTY WEIGHT	3472	1220	
				2.	PAYLOAD	800	520	
Seat 1	37	190	70	3.	* ZERO FUEL WEIGHT (sub-total) (Do not exceed maximum zero fuel weight)	4272	1740	
Seat 2	37	150	56					
Seat 3	68	170	116					
Seat 4	68	150	102					
Seat 5								
Seat 6								
BAGGAGE	126	140	176	4.	FUEL LOADING			
					(main)	600	210	
					(auxiliary)	378	178	
					(wing lockers)	---	---	
PAYLOAD	---	800	520	5.	* TAKEOFF WEIGHT (See Figure 6-2)	5250	2128	
				6.	LESS FUEL TO DESTINATION			
						(main)	155	54
						(auxiliary)	378	178
					(wing lockers)	---	---	
				7.	* LANDING WEIGHT (See Figure 6-2)	4717	1896	

*Totals must be within approved weight and C.G. limits. It is the responsibility of the airplane owner and the pilot to insure that the airplane is loaded properly. The Basic Empty Weight C.G. is noted on the Airplane Weighing Form. If the airplane has been altered, refer to the Weight and Balance Record for this information.

Figure 6-3

Determine arm, weight and Moment/100 of the crew, passengers and baggage from Figure 6-2 and enter them under Payload Computations in Figure 6-3. The crew and passenger loading table is applicable only when the CG of the occupant is at the location specified.

If the seats are in any other position than stated in Figure 6-2, the moment must be computed by multiplying occupant weight times the arm in inches. A point 9 inches forward of the intersection of the seat bottom and seat back with seat cushions compressed can be assumed to be the occupant CG. For a reference in determining the arm, the forward face of the cabin doorway structure is fuselage station 20.00.

See Figure 6-3. Total the Payload Computations items and enter the resulting Weight and Moment/100 in item 2.

See Figure 6-3. Total items 1 (Basic Empty Weight) and 2 (Payload) to determine appropriate entries for item 3 (Zero Fuel Weight).

See Figure 6-3. Item 4 (Fuel Loading), is determined from the applicable columns of Figure 6-2.

Total items 3 and 4 to determine 5 (Takeoff Weight). Enter item 5 in Figure 6-2 to determine if the loading is within allowable limits. If the point falls within the envelope, the loading is approved. If the point falls outside the envelope, it will be necessary to redistribute the load.

Refer to Section 5 for estimated fuel used during the flight. After determining the fuel used, obtain the appropriate weights and Moment/100 from Figure 6-2. Enter the total of these weights and Moment/100 in item 6 (Less Fuel To Destination).

Item 7 (Landing Weight) is determined by subtracting item 6 from item 5. Enter item 7 in Figure 6-2 to determine if the loading is within allowable limits. If the point falls within the envelope, the loading is approved. If the point falls outside the envelope, it will be necessary to redistribute the load.

WEIGHT AND BALANCE RECORD

The Weight and Balance Record, see Figure 6-4, provides a record to reflect the continuous history of changes in airplane structure and/or equipment which affects the weight and balance of the airplane.

The Basic Empty Weight of your airplane is entered at the appropriate location on the Weight and Balance Data sheet as delivered from the factory. Changes to the structure or equipment should be entered on the Weight and Balance Record when any modifications are made to the airplane. It is the responsibility of the airplane owner to assure this record is up to date, as all loadings will be based on the latest entry.

EQUIPMENT LIST

The following pages of this handbook contain a comprehensive listing of all equipment available from the factory for the 310 airplane. This equipment list is divided into two sections, the first of which (Section A) lists all equipment required to be installed. The second section (Section B) lists the remaining standard equipment and all available optional equipment.

A "Mark If Installed" column has been provided after each item in the equipment list. If desired, the operator may check each appropriate item which is installed in his particular airplane. Columns showing weight in pounds and arm in inches provide the weight and center of gravity location for the equipment.

A customized equipment list, detailing only the equipment installed in your airplane as delivered from the factory, is provided with your airplane papers. This list is presented in the same order and format as the comprehensive listing.

WEIGHT AND BALANCE RECORD

(CONTINUOUS HISTORY OF CHANGES IN STRUCTURE OR EQUIPMENT
AFFECTING WEIGHT AND BALANCE)

DATE	ITEM	DESCRIPTION OF ARTICLE OR MODIFICATION	WEIGHT CHANGE				BASIC EMPTY WEIGHT	
			ADDED (+)		REMOVED (-)		WT (LB)	MOMENT /100
			WT. (LB)	ARM (IN)	WT. (LB)	ARM (IN)		

Figure 6-4

EQUIPMENT LIST

AIRPLANE SERIAL NO. 310R0501 THRU 310R0800

THE FOLLOWING IS A COMPLETE LIST OF EQUIPMENT WHICH CAN BE INSTALLED IN THE AIRPLANE WHEN DELIVERED BY CESSNA AIRCRAFT COMPANY. REFER TO THE EQUIPMENT LIST IN THE AIRPLANE FOR A LIST OF EQUIPMENT ACTUALLY INSTALLED WHEN DELIVERED BY CESSNA AIRCRAFT COMPANY.
 DATUM STATION 0.0 IS AT THE FORWARD FACE OF THE FUSELAGE BULKHEAD JUST FORWARD OF THE RUDDER PEDALS.
 NEGATIVE ARMS ARE DISTANCES FORWARD OF DATUM STATION 0.0.
 POSITIVE ARMS ARE DISTANCES AFT OF DATUM STATION 0.0.
 AN ASTERISK (*) INDICATES EXCHANGE WEIGHT.
 INSTALLATION APPROVAL OF EQUIPMENT INCLUDED IN THIS LIST IS MAINTAINED EITHER BY THE MANUFACTURER'S STANDARD WITH THE APPROVAL NUMBER NOTED WITH EQUIPMENT OR IN THE MANUFACTURER'S TYPE DESIGN FILE IN ACCORDANCE WITH DELEGATION OPTION AUTHORIZATION CE-3.

SECTION A
REQUIRED EQUIPMENT

FACTORY KIT	ITEM	PART NUMBER	MARK IF INSTALLED	QUANTITY	WEIGHT (POUNDS)	ARM (INCHES)
	WHEEL-MAIN GEAR 650X10	C163001201		2	28.0	55.6
	TIRE-MAIN GEAR 650X10 6 PLY	C262003209		2	22.4	55.6
	TUBE-MAIN GEAR 650X10 TYPE III	C262023105		2	5.6	55.6
	BRAKE-MAIN GEAR	C163030201		2	8.4	55.6
	WHEEL-NOSE GEAR 600X6	C163010101		1	5.0	-50.4
	TIRE-NOSE GEAR 600X6 4 PLY	C262003203		1	6.5	-50.4
	TUBE-NOSE GEAR 600X6 TYPE III	C262023102		1	1.7	-50.4
	ENGINE CMC 6 CYL 285 HP 2700RPM	10-520-M		2	848.9	-3.0
	FILTER-AIR INDUCTION	9910018		2	1.8	30.9
	EXHAUST SYSTEM	5207827000		2	37.8	10.4
	OIL RADIATOR (MODINE)	IE-1774-D		2	14.8	8.0
	FUEL PUMP-CMC-ENGINE DRIVEN	632818		2	5.2	14.7
	FUEL PUMP-800ST	0850420		1	6.0	47.1

SECTION A
REQUIRED EQUIPMENT

FACTORY KIT	ITEM	PART NUMBER	MARK IF INSTALLED	QUANTITY	WEIGHT (POUNDS)	ARM (INCHES)
	FUEL PUMP-TRANSFER BENDIX	476411		2	5.6	58.8
	PROPELLER 3-BLADE	0850334 26		2	155.0	-27.1
	PROP SPINNER & BULKHEAD	D3534D3796		2	10.4	-27.4
	PROP GOVERNOR	DCF290D4T3		1	3.4	-17.7
	PROP GOVERNOR	DCF290D5T3		1	4.1	-17.7
	ALTIMETER	C661014101		1	1.1	13.5
	AIRSPEED INDICATOR	C661040108		1	0.7	13.0
	TACHOMETER-DUAL	C668017107		1	1.8	13.5
	COMPASS	C660501103		1	0.6	13.0
	FUEL QUANTITY INDICATOR-DUAL	9910082 1		1	1.0	14.6
	FUEL FLOW INDICATOR - DUAL	C662020109		1	1.1	15.2
	MANIFOLD PRESSURE GAGE - DUAL	C662026108		1	1.0	14.2
	LEFT ENGINE GAGE	C662019101		1	1.3	15.0
	RIGHT ENGINE GAGE	C662019101		1	1.3	15.0
	ALTERNATOR 50 AMP	0850915 1		2	26.2	-17.9
	VOLTAGE REGULATOR 50 AMP	9910126 2		2	1.8	36.1
	BATTERY 24 VOLT	9910128 1		1	42.0	44.3
	HORN-STALL WARNING SYSTEM	0511062 14		1	1.4	-0.0
	SEAT-PILOT ADJUSTABLE	0812782 1		1	16.2	44.6
	BELT & SHOULDER HARNESS PILOT	0812865 1		1	1.7	49.5
	PILOT CHECK LIST					

SECTION B
STANDARD AND OPTIONAL EQUIPMENT

FACTORY KIT	ITEM	PART NUMBER	MARK IF INSTALLED	QUANTITY	WEIGHT (POUNDS)	ARM (INCHES)
	CONTROLS & AUTOFLIGHT					
33.00	ELECTRIC ELEVATOR TRIM	0832107 4		1	2.8	190.5
24.00	CONTROLS COPILOT	0861350 10		1	5.5	14.8
47.00	GUST LOCK INSTL-RUDDER PEDALS	0861701 1		1	0.8	19.8
	GYRO-DIRECTIONAL C661053-101			1	2.5	12.8
533.01	GYRO-DIRECT G-502A			1	3.0	12.8
533.02	GYRO-DIRECT G-504A			1	3.1	12.8
533.03	GYRO-HSI 3 IG-832A			1	5.3	12.8
533.04	GYRO-HSI 4 IG-895A			1	5.3	12.8
	GYRO-HORIZONTAL C661055-102			1	2.6	12.3
533.10	GYRO-HORIZ G-519B-1			1	2.5	12.3
533.11	GYRO-HORIZ G-550A			1	3.7	12.3
533.12	GYRO-HORIZ G-895A			1	5.3	12.3
530.00	400B NAV-0-MATIC INSTL			1	2.3	11.0
530.00	COMPUTER CA-550A/FD			1	5.8	138.9
530.00	CONTROLLER C-530A			1	1.3	20.0
530.00	ACTUATOR PA-495A-1			2	8.4	141.9
530.00	ACTUATOR TA-495A			1	2.1	148.4
530.00	ALTITUDE SENSOR AS-895A			1	2.3	154.4
530.00	SUPPORT			1	2.2	143.4
530.00	WIRING			1	7.3	76.0
530.00	AUTOPILOT CHECK LIST			1	0.0	0.0
530.00	400B NAV-0-MATIC SLAVED DG OPT			1	1.6	128.5
531.00	FLUX DETECTOR CT-504A			1	0.4	225.0
531.01	SLAVE ACCESS W/O BS SA-832A			1	0.5	140.0
531.02	SLAVE ACCESS W/BS SA-832B			1	1.6	140.0
532.00	400B NAV-0-MATIC HSI 3 OPT			1	1.0	11.0
532.01	CONVERTER B-841A			1	2.1	-63.0
532.01	MOUNT 36450			1	0.9	-63.0

SECTION B
STANDARD AND OPTIONAL EQUIPMENT

FACTORY KIT	ITEM	PART NUMBER	MARK IF INSTALLED	QUANTITY	WEIGHT (POUNDS)	ARM (INCHES)
532.00	FLUX DETECTOR CT-504A			1	0.4	225.0
532.02	SLAVE ACCESS W/O BS SA-832A			1	0.5	140.0
532.03	SLAVE ACCESS W/BS SA-832B			1	1.6	140.0
534.00	YAW DAMPER INSTL YD-840B			1	1.6	184.4
534.00	ACTUATOR PA-495A-1			1	4.2	179.6
534.00	GYRO-COMPUTER G-840A			2	2.4	13.8
540.00	300B IFCS INSTL			1	2.5	11.0
540.00	COMPUTER CA-550A/FD			1	5.8	138.9
540.00	CONTROLLER C-531A			1	1.3	23.0
540.00	ACTUATOR PA-495A-1			2	8.4	141.9
540.00	ACTUATOR TA-495A			2	2.1	148.4
540.00	ALTITUDE SENSOR AS-895A			2	2.3	154.4
540.00	SUPPORT			2	3.8	143.4
540.00	WIRING			2	7.3	76.0
540.00	MODE SELECTOR S-550A			1	2.6	13.0
540.00	FLUX DETECTOR CT-504A			1	0.4	225.0
540.01	SLAVE ACCESS W/O BS SA-832A			1	0.5	140.0
540.02	SLAVE ACCESS W/BS SA-832B			1	1.6	140.0
540.03	CONVERTER B-841A			1	2.1	-63.0
540.03	MOUNT 36450			1	0.3	-63.0
540.00	AUTOPILOT CHECK LIST			1	0.0	0.0
550.00	400B IFCS INSTL			1	2.5	11.0
550.00	COMPUTER CA-550A/FD			1	5.8	138.9
550.00	CONTROLLER C-531A			1	1.3	23.0
550.00	ACTUATOR PA-495A-1			2	8.4	141.9
550.00	ACTUATOR TA-495A			1	2.1	148.4
550.00	ALTITUDE SENSOR AS-895A			1	2.3	154.4
550.00	SUPPORT			1	3.8	143.4
550.00	WIRING			1	7.3	76.0
550.00	MODE SELECTOR S-550A			1	2.6	13.0

SECTION B
STANDARD AND OPTIONAL EQUIPMENT

FACTORY KIT	ITEM	PART NUMBER	MARK IF INSTALLED	QUANTITY	WEIGHT (POUNDS)	ARM (INCHES)
550.00	FLUX DETECTOR CT-504A			1	0.4	225.0
550.01	SLAVE ACCESS W/O BS SA-832A			1	0.5	140.0
550.02	SLAVE ACCESS W/BS SA-832B			1	1.6	140.0
550.03	CONVERTER B-841A			1	2.1	-63.0
550.03	MOUNT 36450			1	0.9	-63.0
550.04	CONVERTER B-841A			1	2.1	-63.0
550.04	MOUNT 36450			1	0.9	-63.0
550.05	INDICATOR IN-832R			1	0.8	13.0
550.06	GYRO-HSI 3 IG-832A RH			1	5.3	12.8
550.06	FLUX DETECTOR CT-504A			1	0.4	225.0
550.07	SLAVE ACCESS W/O BS SA-832A			1	0.5	140.0
550.08	SLAVE ACCESS W/BS SA-832B			1	1.6	140.0
550.09	GYRO-ADI 3 G-550A RH			1	3.7	12.8
550.00	AUTOPILOT CHECK LIST			1	0.0	0.0
533.30	HORIZ SITUATION IND W/O N-O-M I			1	1.0	11.0
533.30	FLUX DETECTOR			1	0.4	225.0
533.31	SLAVE ACCESS W/O BS SA-832A			1	0.5	140.0
533.32	SLAVE ACCESS W/BS SA-832A			1	1.6	140.0
533.33	CONVERTER B-841A			1	2.1	-63.0
533.33	MOUNT 36450			1	0.9	-63.0
27.00	INTERNAL CORROSION PROOFING	0800169	1	1	8.5	86.1
27.00	CABLES STAINLESS STEEL	0860207	1	1*	0.0	0.0
FUEL SYSTEM						
40.00	FUEL SYS-WING LOCKER RH&LH 40 G	5226001	11	1	27.8	47.8
40.10	FUEL SYS-WING LOCKER LH 20 GAL	5226001	7	1	13.9	47.8
40.20	FUEL SYS-WING LOCKER RH 20 GAL	5226001	6	1	13.9	47.8
38.00	FUEL SYS-WING AUXILIARY 40 GAL	0826036	3	1	47.9	48.3
178.00	FUEL SYS-WING AUXILIARY 63 GAL	0826036	4	1	60.2	48.3

**SECTION B
STANDARD AND OPTIONAL EQUIPMENT**

FACTORY KIT	ITEM	PART NUMBER	MARK IF INSTALLED	QUANTITY	WEIGHT (POUNDS)	ARM (INCHES)
72.00	FUEL SYS-PART'L PLUMB LH&RH LKR	5226001 44		1	5.2	39.0
72.10	FUEL SYS-PART'L PLUMB LH LOCKER	5226001 41		1	2.6	39.0
72.20	FUEL SYS-PART'L PLUMB RH LOCKER	5226001 42		1	2.6	39.0
	PROPELLER					
77.00	PROP UNFEATHERING SYSTEM	0850454 1		2	10.3	-5.8
77.00	PROP GOVERNOR- UNFEATHERING LH	DCFU290D4T3		1	3.6	-17.7
77.00	PROP GOVERNOR- UNFEATHERING RH	DCFU290D5T3		1	4.3	-17.7
76.10	PROP SYNCHROPHASER AUTOMATIC	0850735 1		2	2.9	9.3
76.10	PROP GOVERNOR- SYNCHROPHASER LH	DCFS290D4T3		1	3.4	-17.7
76.10	PROP GOVERNOR- SYNCHROPHASER RH	DCFS290D5T3		1	4.1	-17.7
76.20	PROP UNFEATHERING/SYNCHROPHASER	0850735 3		2	13.2	-2.5
76.20	PROP GOVERNOR- UNFEATH/SYNCH LH	DCFUS290D4T3		1	3.6	-17.7
76.20	PROP GOVERNOR-UNFEATH/SYNCH RH	DCFUS290D5T3		1	4.3	-17.7
	INSTRUMENTS					
1.10	ALTIMETER FT & MILIBARS LH	0813406 1		1	1.1	13.5
624.30	400 ENCODING ALTIMETER-INCHES	EA-401A		1	2.6	13.0
624.50	400 ENCODING ALTIMETER-MILIBARS	EA-401A		1	2.6	13.0
624.20	400 ENCODING ALTIMETER-INCHES	EA-401A		1	2.6	13.0
624.40	400 ENCODING ALTIMETER-MILIBARS	EA-401A		1	2.6	13.0
675.10	800 ENCODING ALTIMETER-INCHES	EA-801A		1	2.8	13.0
675.10	ALTITUDE ALERTER AA-801A	EA-801A		1	0.8	13.0
675.20	800 ENCODING ALTIMETER-MILIBARS	EA-801A		1	2.8	13.0
675.20	ALTITUDE ALERTER AA-801A	EA-801A		1	0.8	13.0
676.10	800 ENCODING ALTIMETER-INCHES	EA-801A		1	2.8	13.0
676.10	ALTITUDE ALERTER AA-801A	EA-801A		1	0.8	13.0
676.20	800 ENCODING ALTIMETER-MILIBARS	EA-801A		1	2.8	13.0

**SECTION B
STANDARD AND OPTIONAL EQUIPMENT**

FACTORY KIT	ITEM	PART NUMBER	MARK IF INSTALLED	QUANTITY	WEIGHT (POUNDS)	ARM (INCHES)
676.20	ALTITUDE ALERTER AA-801A	0813403 1		1	0.8	13.0
4.00	AIRSPEED INDICATOR TAS LH	0813413 2		1	2.8	13.0
9.00	TACHOMETER SYNCHRONOUS-DUAL	0800302 1		1	1.8	13.5
11.00	ANGLE OF ATTACK SYSTEM	C661035101	STD	1	0.8	11.5
	RATE OF CLIMB INDICATOR	0870071 5	STD	1	0.9	13.0
8.00	RATE OF CLIMB INDICATOR-INSTANT	C664506102	STD	1	1.9	13.0
	CLOCK	0813407 1		1	0.4	14.2
23.00	CLOCK GREENWICH MEANTIME	C661032101	STD	1	0.4	14.2
	TURN & BANK INDICATOR	0813404 1		1	1.1	13.0
5.00	TURN COORDINATOR	0870121 5		1	2.5	13.0
3.00	FLIGHT HOUR RECORDER	0870063 3		1	0.8	21.3
6.00	OUTSIDE AIR TEMPERATURE IND	0851851 11		1	1.0	3.2
2.00	ECONOMY MIXTURE INDICATOR	0814551-2		1	2.3	15.1
7.00	RH PANEL & PLUMBING	C661014101	RH	1	5.1	12.9
7.10	ALTIMETER	0813406 1	RH	1	1.1	13.5
1.20	ALTIMETER FT & MILIBARS	C661040208	RH	1	1.1	13.5
7.20	AIRSPEED INDICATOR	0813403 3	RH	1	0.7	13.0
4.10	AIR SPEED INDICATOR TAS	C661035101	RH	1	2.8	13.0
7.30	RATE OF CLIMB INDICATOR	0870071 5	RH	1	0.9	13.0
8.10	RATE OF CLIMB INDICATOR	C661053101	RH	1	1.9	13.0
7.40	GYRO-DIRECTIONAL	C661035102	RH	1	2.5	12.8
7.50	GYRO-HORIZONTAL	0813082 2	RH	1	2.6	12.3
7.60	PITOT TUBE SYSTEM	0814170 1	RH	1	1.0	10.9
7.70	DUAL STATIC SOURCE	C661032101	RH	1	0.3	177.1
19.00	TURN & BANK INDICATOR	5118648 8		1	1.1	13.0
45.00	FUEL LOW LEVEL WARNING			1	0.8	37.5
	PNEUMATIC					
	VACUUM PUMPS-PWR FOR GYROS	212CW	STD	2	3.8	11.0
32.00	VACUUM PUMPS-PWR FOR DE-ICE SYS	A505CDD	STD	2	10.1	11.0

**SECTION B
STANDARD AND OPTIONAL EQUIPMENT**

FACTORY KIT	ITEM	PART NUMBER	MARK IF INSTALLED	QUANTITY	WEIGHT (POUNDS)	ARM (INCHES)
	ELECTRICAL					
16.10	ALTERNATOR 100 AMP INSTL	0850916	1	2	49.0	-17.9
16.10	VOLTAGE REGULATOR 100 AMP	9910126	2	2	1.8	36.1
43.00	LIGHTS, COURTESY (NACELLE-NOSE)	0851862	1	1	1.0	40.2
46.00	GROUND SERVICE PLUG	0818104	1	1	5.1	104.4
48.00	LIGHT, ICE DETECTION (LH)	0820520	4	1	0.4	27.3
48.10	LIGHT, ICE DETECTION (RH)	0820520	5	1	0.4	27.3
49.00	LIGHT, LANDING (RH)	0820300	13	1	6.0	65.1
51.00	LIGHT, ROTATING BEACON-RUDDER MT	0831017	38	1	1.5	197.5
51.10	LIGHT, ROTATING BEACON-DUAL	0831017	39	1	3.8	96.3
	LIGHT, CIRCUIT BREAKER PANEL-STD	0813682	1	1	4.7	27.3
53.10	LIGHT, CIRCUIT BREAKER PANEL-EL	0800316	13	1	6.8	28.6
100.00	LIGHTS, COURTESY, WING WALK-STEP	0811082	1	1	1.4	77.9
96.00	LIGHTS, STROBE (THREE UNITS)	0823019	1	1	11.0	73.3
52.00	LIGHT, TAXI	5618101	6	1	1.5	-35.6
87.00	STATIC DISCHARGERS	0812687	2	1	0.1	208.4
	ELECTRONICS					
300.00	300 NAV/COM INSTL			1	2.1	-13.0
300.00	TRANSCEIVER RT-328T			1	7.0	10.7
300.00	MOUNT 40550			1	0.6	10.7
300.01	INDICATOR IN-525B			1	0.8	13.3
300.00	CONVERTER P-528A			1	1.1	-63.0
300.02	300 NAV/COM INSTL			1	2.1	-13.0
300.02	TRANSCEIVER RT-328T			1	7.0	10.7
300.02	MOUNT 40550			1	0.6	10.7
300.03	INDICATOR IN-514B			1	0.8	13.3
301.03	INDICATOR IN-525B			1	0.8	13.3

SECTION B
STANDARD AND OPTIONAL EQUIPMENT

FACTORY KIT	ITEM	PART NUMBER	MARK IF INSTALLED	QUANTITY	WEIGHT (POUNDS)	ARM (INCHES)
300.02	CONVERTER P-528A			1	1.1	-63.0
300.04	400 GLIDE SLOPE INSTL			1	2.9	-50.0
300.04	RECEIVER R-443B			1	2.4	-63.0
300.04	MOUNT 36450			1	0.9	-63.0
300.04	ANTENNA RGS-10-4B			1	0.1	-92.0
300.05	400 MARKER BEACON INSTL			1	2.9	45.9
300.05	RECEIVER R-402A & MOUNT			1	1.1	-63.0
300.05	ANTENNA A-24A			1	0.7	154.8
300.06	300 ADF INSTL			1	2.5	56.7
300.06	RECEIVER R-546E			1	3.4	12.8
300.06	MOUNT 40900			1	0.5	12.8
300.07	INDICATOR IN-346A			1	1.1	16.1
301.07	ACCESSORY UNIT RA-446A			1	1.4	2.5
300.06	ANTENNA LOOP L-346A			1	1.7	138.9
300.06	ANTENNA SENSE			1	3.0	59.1
300.20	ANTENNA-COM 1, A-29C			1	0.9	112.5
300.21	ANTENNA-COM 2, FLN TIP VF10-122			1	1.6	191.0
300.22	ANTENNA-DUAL NAV, VT10-56-5			1	2.9	228.0
300.23	ANTENNA-SINGLE NAV, VT10-50			1	1.6	228.0
300.24	AUDIO SYS ASB-130	9760274		1	0.8	13.0
300.26	AVIONICS BUS	0818103		1	0.7	23.4
300.25	JUNCTION BLOCK	9754054		1	2.5	-25.0
300.27	KIT-MIC & FILTER INSTL	310-1336-3		1	0.6	20.4
300.28	HEADSET	0770039		2	0.4	29.7
300.30	CHART HOLDER	0819011		1	0.2	32.9
300.31	SHELF-LOWER	9756073		1	2.3	-66.1
310.00	300 NAV/COM INSTL (EXPORT)			1	2.1	-13.0
310.00	TRANSCIEVER RT-528E-1			1	7.3	10.7
310.00	MOUNT 4055C			1	0.6	10.7
310.01	INDICATOR IN-525B			1	0.8	13.3

SECTION B
STANDARD AND OPTIONAL EQUIPMENT

FACTORY KIT	ITEM	PART NUMBER	MARK IF INSTALLED	QUANTITY	WEIGHT (POUNDS)	ARM (INCHES)
310.00	CONVERTER P-528A			1	1.1	-63.0
310.02	300 NAV/COM INSTL (EXPORT)			1	2.1	-13.0
310.02	TRANSCIVER RT-528E-1			1	7.3	10.7
310.02	MOUNT 40550			1	0.6	10.7
310.03	INDICATOR IN-514B			1	0.8	13.3
311.03	INDICATOR IN-525B			1	0.8	13.3
310.03	CONVERTER P-528A			1	1.1	-63.0
310.04	GLIDE SLOPE/MKR BCN I (EXPORT)			1	2.9	4.0
310.04	RECEIVER GM-247A & MOUNT			1	2.7	-63.0
310.04	ANTENNA RGS-10-48			1	0.1	-92.0
310.04	ANTENNA A-24A			1	0.7	154.8
310.06	300 ADF INSTL (EXPORT)			1	2.5	56.7
310.06	RECEIVER R-546E			1	3.4	12.8
310.06	MOUNT 40900			1	0.5	12.8
310.07	INDICATOR IN-346A			1	1.1	16.1
311.07	ACCESSORY UNIT RA-446A			1	1.4	2.5
310.06	ANTENNA LOOP L-346A			1	1.7	138.9
310.06	ANTENNA SENSE			1	3.0	59.1
400.00	400 NAV/COM INSTL			1	3.7	11.5
400.00	TRANSCIVER RT-428A			1	6.7	9.7
400.00	MOUNT 40550			1	0.6	9.7
400.01	INDICATOR IN-443A			1	2.5	16.1
401.01	INDICATOR IN-443B			1	2.5	16.1
400.02	400 NAV/COM INSTL			1	3.7	11.5
400.02	TRANSCIVER RT-428A			1	6.7	9.7
400.02	MOUNT 40550			1	0.6	9.7
400.03	INDICATOR IN-442A			1	2.5	16.1
401.03	INDICATOR IN-442B			1	2.5	16.1
401.04	INDICATOR IN-443A			1	2.5	16.1
401.05	INDICATOR IN-443B			1	2.5	16.1

SECTION B
STANDARD AND OPTIONAL EQUIPMENT

FACTORY KIT	ITEM	PART NUMBER	MARK IF INSTALLED	QUANTITY	WEIGHT (POUNDS)	ARM (INCHES)
400.04	400 GLIDE SLOPE INSTL			1	2.9	-50.0
400.04	RECEIVER R-443B			1	2.4	-63.0
400.04	MOUNT 36450			1	0.9	-63.0
400.04	ANTENNA RGS-10-48			1	0.1	-92.0
400.05	400 MARKER BEACON INSTL			1	2.9	45.9
400.05	RECEIVER R-402A & MOUNT			1	1.1	-63.0
400.05	ANTENNA A-24A			1	0.7	154.8
400.06	400 ADF INSTL			1	3.2	56.7
400.06	RECEIVER R-446A			1	3.5	12.8
400.06	MOUNT 40900			1	0.5	12.8
400.07	INDICATOR IN-346A			1	1.1	16.1
401.07	ACCESSORY UNIT RA-446A			1	1.4	2.5
400.06	ANTENNA LOOP L-346A			1	1.7	138.9
400.06	ANTENNA SENSE			1	3.0	59.1
400.20	ANTENNA-COM 1, A-29C			1	0.9	112.5
400.21	ANTENNA-COM 2, FIN TIP VF10-122			1	1.6	191.0
400.22	ANTENNA-DUAL NAV, VT10-56-5			1	2.9	228.0
400.23	ANTENNA-SINGLE NAV, VT10-50			1	1.6	228.0
400.13	AUDIO SYS ASP-310	9760274		1	0.8	13.0
400.14	AVIONICS BUS	0818103		1	0.7	23.4
400.15	JUNCTION BLOCK	9754054		1	2.5	-25.0
400.16	KIT-MIC & FILTER INSTL	310-1336-3		1	0.6	20.4
400.17	CHART HOLDER	0819011		1	0.2	32.9
400.18	SHELF-LOWER	9756073		1	2.3	-66.1
400.19	HEADSET	0770039		1	0.4	29.7
800.00	800 COM INSTL NO 1			1	3.5	-37.2
800.00	TRANSCIVER RT-831A			1	4.3	-63.0
800.00	MOUNT 36280			1	0.3	-63.0
800.00	CONTROL C-831A			1	1.5	14.3
800.00	ACCESSORY UNIT RTA-831B			1	6.2	-63.0

**SECTION B
STANDARD AND OPTIONAL EQUIPMENT**

FACTORY KIT	ITEM	PART NUMBER	MARK IF INSTALLED	QUANTITY	WEIGHT (POUNDS)	ARM (INCHES)
800.00	MOUNT 36450			1	0.9	-63.0
800.01	800 COM INSTL NO 2			1	3.5	-37.2
800.01	TRANSCEIVER RT-831A			1	4.3	-63.0
800.01	MOUNT 36280			1	0.3	-63.0
800.01	CONTROL C-831A			1	1.5	14.3
800.01	ACCESSORY UNIT RTA-831B			1	6.2	-63.0
800.01	MOUNT 36450			1	0.9	-63.0
800.02	800 NAV INSTL NO U			1	2.1	-24.9
800.02	RECEIVER R-41A			1	2.8	-63.0
800.02	MOUNT 36450			1	0.9	-63.0
800.02	CONTROL C-841A			1	1.4	14.3
800.03	INDICATOR IN-41A			1	2.1	13.0
801.03	INDICATOR IN-41D			1	2.1	13.0
800.04	CONVERTER B-841A			1	2.1	-63.0
800.04	MOUNT 36450			1	0.9	-63.0
800.05	800 NAV INSTL NO 2			1	2.1	-24.9
800.05	RECEIVER R-41A			1	2.8	-63.0
800.05	MOUNT 36450			1	0.9	-63.0
800.05	CONTROL C-841A			1	1.4	14.3
800.06	INDICATOR IN-41A			1	2.1	13.0
801.06	INDICATOR IN-41D			1	2.1	13.0
800.07	CONVERTER B-841A			1	2.1	-63.0
800.07	MOUNT 36450			1	0.9	-63.0
800.08	800 GLIDE SLOPE INSTL			1	2.0	-63.0
800.08	RECEIVER R-843A			1	2.0	-63.0
800.08	MOUNT 36450			1	2.1	-63.0
800.08	ANTENNA RGS-10-48			1	0.9	-63.0
800.09	400 MARKER BEACON INSTL			1	0.1	-92.0
800.09	RECEIVER R-402A & MOUNT			1	2.9	45.9
800.09	ANTENNA A-24A			1	1.1	-63.0
800.09				1	0.7	154.8

SECTION B
STANDARD AND OPTIONAL EQUIPMENT

FACTORY KIT	ITEM	PART NUMBER	MARK IF INSTALLED	QUANTITY	WEIGHT (POUNDS)	ARM (INCHES)
800.10	800 ADF INSTL			1	3.2	57.8
800.10	RECEIVER R-846A			1	3.8	-63.0
800.10	MOUNT 40830			1	0.8	-63.0
800.10	CONTROL C-846A			1	1.4	13.0
800.11	INDICATOR IN-346A			1	1.1	13.0
800.12	ACCESSORY UNIT RA-846A			1	1.4	2.5
800.10	ANTENNA LOOP L-346A			1	1.7	138.9
800.10	ANTENNA SENSE			1	3.0	59.1
800.21	ANTENNA-COM 1, A-29C			1	0.9	112.5
800.22	ANTENNA-COM 2, FIN TIP VF10-122			1	1.6	191.0
800.23	ANTENNA-DUAL NAV, VT10-56-5			1	2.9	228.0
800.24	ANTENNA-SINGLE NAV, VT10-50			1	1.6	228.0
800.14	AUDIO SYSTEM	9752007		1	0.8	13.0
800.15	KIT-MIC & FILTER INSTL	10-1336		3	0.6	20.4
800.16	SHELF INSTL LOWER	9756073		1	2.3	-66.2
800.17	HEADSET	0770039		1	0.4	29.7
800.18	J-BOX INSTL	9754019		1	2.5	-25.0
800.19	AVIONICS BUS	0818103		1	0.7	23.4
800.20	CHART HOLDER	0819011		1	0.2	32.9
810.00	800 COM INSTL NO 1 (EXPORT)			1	3.5	-37.2
810.00	TRANSCIEVER RT-831A			1	4.3	-63.0
810.00	MOUNT 36280			1	0.3	-63.0
810.00	CONTROL C-831A			1	1.5	14.3
810.00	ACCESSORY UNIT RTA-831B			1	6.2	-63.0
810.00	MOUNT 36450			1	0.9	-63.0
810.01	800 COM INSTL NO 2 (EXPORT)			1	3.5	-37.2
810.01	TRANSCIEVER RT-831A			1	4.3	-63.0
810.01	MOUNT 36280			1	0.3	-63.0
810.01	CONTROL C-831A			1	1.5	14.3
810.01	ACCESSORY UNIT RTA-831B			1	6.2	-63.0

SECTION B
STANDARD AND OPTIONAL EQUIPMENT

FACTORY KIT	ITEM	PART NUMBER	MARK IF INSTALLED	QUANTITY	WEIGHT (POUNDS)	ARM (INCHES)
810.01	MOUNT 36450			1	0.9	-63.0
810.02	800 NAV INSTL NO 1 (EXPORT)			1	2.1	-24.9
810.02	RECEIVER R-41A			1	2.8	-63.0
810.02	MOUNT 36450			1	0.9	-63.0
810.02	CONTROL C-841A			1	1.4	14.3
810.03	INDICATOR IN-41A			1	2.1	13.0
811.03	INDICATOR IN-41D			1	2.1	13.0
310.04	CONVERTER B-841A			1	2.1	-63.0
810.04	MOUNT 36450			1	0.9	-63.0
810.05	800 NAV INSTL NO 2 (EXPORT)			1	2.1	-24.9
810.05	RECEIVER R-41A			1	2.8	-63.0
810.05	MOUNT 36450			1	0.9	-63.0
810.05	CONTROL C-841A			1	1.4	14.3
810.06	INDICATOR IN-41A			1	2.1	13.0
811.06	INDICATOR IN-41D			1	2.1	13.0
810.07	CONVERTER B-841A			1	2.1	-63.0
810.07	MOUNT 36450			1	0.9	-63.0
810.08	GLIDE SLOPE/MKR BCN I (EXPORT)			1	2.9	-50.0
810.08	RECEIVER GN-247A & MOUNT			1	2.7	-63.0
810.08	ANTENNA RGS-10-48			1	0.1	-92.0
810.08	ANTENNA A-24A			1	0.7	167.5
810.10	800 ADF INSTL (EXPORT)			1	3.2	57.8
810.10	RECEIVER R-846A			1	3.8	-63.0
810.10	MOUNT 40830			1	0.8	-63.0
810.10	CONTROL C-846A			1	1.4	13.0
810.11	INDICATOR IN-346A			1	1.1	13.0
810.12	ACCESSORY UNIT RA-846A			1	1.4	2.5
810.10	ANTENNA LOOP L-346A			1	1.7	138.9
810.10	ANTENNA SENSE			1	3.0	59.1
800.14	800 COM CONTROL HEAD C-831S			1	1.4	14.3

SECTION B
STANDARD AND OPTIONAL EQUIPMENT

FACTORY KIT	ITEM	PART NUMBER	MARK IF INSTALLED	QUANTITY	WEIGHT (POUNDS)	ARM (INCHES)
622.00	400 TRANSPONDER INSTL			1	0.6	-29.6
622.00	TRANSCIEVER RT-459A & MOUNT			1	3.2	10.5
622.00	ANTENNA L10-216			1	0.3	-69.8
623.00	800 TRANSPONDER INSTL			1	0.6	-29.6
623.00	TRANSCIEVER RT-859A & MOUNT			1	3.2	10.5
623.00	ANTENNA L10-216			1	0.3	-69.8
621.00	TPR-660 TRANSPONDER I (EXPORT)			1	0.6	-29.6
621.00	TRANSCIEVER TRP-661A & MOUNT			1	2.7	10.5
621.00	ANTENNA L10-216			1	0.3	-69.8
681.00	400 DME (476A) INSTL			1	2.7	-5.4
681.00	TRANSCIEVER RTA-476A & MOUNT			1	9.8	-63.0
681.00	CONTROL C-476A			1	1.7	16.0
681.00	ANTENNA A-119A			1	0.3	10.5
629.00	AVQ-47 RADAR INSTL			1	2.3	-37.1
629.00	TRANSCIEVER MI-585035			1	14.7	-63.0
629.00	MOUNT MI-592032			1	1.0	-63.0
629.00	INDICATOR MI-585036			1	6.3	18.0
629.00	INDICATOR CLAMP MI-592034			1	0.5	14.7
629.00	ANTENNA MI-585034			1	4.2	-63.0
629.00	REFLECTOR MI-592038			1	1.0	-63.0
629.00	WAVEGUIDE MI-592057			1	2.6	-63.0
629.00	INDICATOR HOOD MI-592035			1	1.0	18.0
629.20	RDR-130 RADAR INSTL			1	2.3	-37.1
629.20	TRANSCIEVER RT-131A & MOUNT			1	13.0	-63.0
629.20	INDICATOR IN-132A & MOUNT			1	7.4	18.0
629.20	WAVEGUIDE			1	2.6	-63.0
629.20	ANTENNA DA-144A			1	3.8	-63.0
629.20	REFLECTOR AA-1210A			1	0.9	-63.0
629.20	RDR-150 RADAR INSTL			1	2.3	-37.1
629.20	TRANSCIEVER RT-131A & MOUNT			1	13.0	-63.0

SECTION B
STANDARD AND OPTIONAL EQUIPMENT

FACTORY KIT	ITEM	PART NUMBER	MARK IF INSTALLED	QUANTITY	WEIGHT (POUNDS)	ARM (INCHES)
629.20	INDICATOR IN-152A			1	5.8	18.0
629.20	WAVEGUIDE			1	2.6	-63.0
629.20	ANTENNA AT-133A			1	2.8	-63.0
629.20	REFLECTOR AA-1210A			1	0.9	-63.0
630.00	PT-10A HF INSTL			1	2.4	-27.4
630.00	TRANSCEIVER			1	3.7	-63.0
630.00	LOAD BOX			1	4.7	-35.0
630.00	POWER SUPPLY			1	8.9	-63.0
630.01	ANTENNA, STRAIGHT-30 FT			1	1.3	77.8
630.02	ANTENNA, OPEN VEE-45 FT			1	1.4	80.6
633.00	ASB-130 HF INSTL			1	1.5	-27.4
633.00	TRANSCEIVER			1	7.4	-63.0
633.00	POWER SUPPLY			1	8.8	-63.0
633.00	COUPLER			1	4.8	-35.0
633.00	CONTROL			1	0.7	15.7
633.01	ANTENNA, STRAIGHT-30 FT			1	1.3	77.8
633.02	ANTENNA, OPEN VEE-45 FT			1	1.4	80.6
650.00	300 ADF SECOND UNIT INSTL			1	2.5	29.2
650.00	RECEIVER R-546E			1	3.4	12.8
650.00	MOUNT 40900			1	0.5	12.8
650.01	INDICATOR IN-346A			1	1.1	16.1
653.01	INDICATOR IN-13A-1			1	1.4	16.1
653.02	ACCESSORY UNIT RA-446A			1	1.4	2.5
653.03	ACCESSORY UNIT RA-446A			1	1.4	2.5
653.04	INVERTER DV-20B			1	1.4	2.5
650.00	ANTENNA LOOP L-346A			1	3.7	-63.0
650.00	ANTENNA SENSE			1	1.7	55.6
651.00	400 ADF SECOND UNIT INSTL			1	3.0	59.1
651.00	RECEIVER R-446A			1	3.2	29.2
651.00	MOUNT 40900			1	3.5	12.8
651.00				1	0.5	12.8

SECTION B
STANDARD AND OPTIONAL EQUIPMENT

FACTORY KIT	ITEM	PART NUMBER	MARK IF INSTALLED	QUANTITY	WEIGHT (POUNDS)	ARM (INCHES)
651.01	INDICATOR IN-346A			1	1.1	16.1
654.01	INDICATOR IN-13A-1			1	1.4	16.1
654.02	ACCESSORY UNIT RA-446A			1	1.4	2.5
654.03	ACCESSORY UNIT RA-446A			1	1.4	2.5
654.04	INVERTER DV-20B			1	3.7	-63.0
651.00	ANTENNA LOOP L-346A			1	1.7	55.6
651.00	ANTENNA SENSE			1	3.0	59.1
652.00	800 ADF SECOND UNIT INSTL			1	3.2	13.9
652.00	RECEIVER R-846A			1	3.8	-63.0
652.00	MOUNT 40830			1	0.8	-63.0
652.00	CONTROL C-846A			1	1.4	13.0
652.01	INDICATOR IN-346A			1	1.1	16.0
655.01	INDICATOR IN-13A-1			1	1.4	16.0
655.02	ACCESSORY UNIT RA-846A			1	1.4	2.5
655.03	ACCESSORY UNIT RA-846A			1	1.4	2.5
655.04	INVERTER DV-20B			1	1.4	55.6
652.00	ANTENNA LOOP L-346A			1	1.7	59.1
652.00	ANTENNA SENSE			1	3.0	39.2
682.00	800 RMI SYSTEM INSTL			1	1.2	13.3
682.00	INDICATOR G660502-0202			1	2.6	-63.0
682.00	CONVERTER B-24A & MOUNT			1	5.1	-63.0
682.01	CONVERTER B-24A & MOUNT			1	5.1	-63.0
682.02	FLUX DETECTOR CT-504A			1	0.4	225.0
682.03	SLAVE ACCESS W/O BS SA-832A			1	0.5	16.0
682.04	SLAVE ACCESS W/BS SA-832B			1	1.6	16.0
821.00	IMPROVED ADF IN-346B			1	1.3	13.0
822.00	IMPROVED ADF IN-346C			1	2.1	13.0
823.00	IMPROVED ADF IN-346D			1	2.3	13.0
824.00	IMPROVED ADF RA-346A			1	5.0	54.0
825.00	IMPROVED ADF RA-346B			1	6.2	54.0

SECTION B
STANDARD AND OPTIONAL EQUIPMENT

FACTORY KIT	ITEM	PART NUMBER	MARK IF INSTALLED	QUANTITY	WEIGHT (POUNDS)	ARM (INCHES)
826.00	IMPROVED ADF RA-446A			1	1.4	54.0
827.00	IMPROVED ADF RA-846A			1	1.4	54.0
685.00	400 R-NAV INSTL			1	2.8	10.8
685.00	COMPUTER RN-478A			1	5.1	-63.0
685.01	INDICATOR IN-443AR			1	1.3	13.0
685.02	INDICATOR IN-443BR			1	1.3	13.0
685.03	INDICATOR IN-442AR			1	1.3	13.0
685.04	INDICATOR IN-442BR			1	1.3	13.0
672.00	AA-215 RADIO ALTIMETER INSTL			1	1.3	13.0
672.00	TRANSCEIVER RT-220			1	0.5	125.0
672.00	INDICATOR RA-215			1	6.8	140.4
672.00	ANTENNA AT-220			1	2.6	16.0
145.00	AVIONICS COOLING, INSTRUMENT PNL	9756081		3	1.6	139.0
145.10	AVIONICS COOLING, NOSE COMP DME	9756009		1	0.8	18.0
145.11	AVIONICS COOLING, NOSE COMP 800	9756009		6	2.9	-43.2
82.00	RADIO SHELF INSTL LOWER	9756073		1	2.8	-44.4
82.00	RADIO SHELF INSTL UPPER	9756073		2	2.3	-66.1
141.00	HEADSET W/MIKE PILOT	9754030		5	3.4	-69.9
141.10	HEADSET W/MIKE PILOT & COPILOT	9754030		6	0.4	29.7
0.10	SEAT-PILOT ADJUSTABLE LEATHER	0812782		1	0.8	29.7
89.00	SEAT-PILOT VERT ADJ TILTING	0812780		13	16.8	44.6
89.01	SEAT-PILOT VERT ADJ TILTG LETHR	0812780		13	23.4	44.6
81.00	SEAT-PILOT ELECTRIC ADJUSTING	0812781		5	24.0	44.6
81.01	SEAT-PILOT ELEC ADJUST LEATHER	0812781		5	28.0	44.6
181.00	BELT & SHOULDER HARNESS W/REEL	0811898		1	28.6	44.6
	SEAT-COPILOT ADJUSTABLE STD	0812782		2	1.9	49.5
0.11	SEAT-COPILOT ADJUSTABLE LEATHER	0812782		1	16.2	44.6
89.10	SEAT-COPILOT VERT ADJ TILTING	0812780		2	16.8	44.6
89.11	SEAT-COPILOT VERT ADJ TILTG LTHR	0812780		14	23.4	44.6
81.10	SEAT-COPILOT ELECTRIC ADJUST	0812781		6	24.0	44.6
				1	28.0	44.6

**SECTION B
STANDARD AND OPTIONAL EQUIPMENT**

FACTORY KIT	ITEM	PART NUMBER	MARK IF INSTALLED	QUANTITY	WEIGHT (POUNDS)	ARM (INCHES)
81.11	SEAT-COPILOT ELEC ADJUST LEATH	0812781 6		1	28.6	44.6
	BELT & SHOULDER HARNESS PILOT	0812865 2		1	1.7	49.5
181.10	BELT & SHOULDER HARNESS W/REEL	0811898 2		1	1.9	49.5
	SEAT-REAR RECLINING 3-PLACE STD	0812301 28		1	39.3	76.7
0.10	SEAT-REAR RECLINING 3P LEATHER	0812301 28		1	40.2	76.7
111.00	SEAT CENTER INDIVIDUAL 4-PL	0812875 3		1	43.8	73.4
111.10	SEAT CENTER INDIVIDUAL LEATHER	0812875 3		1	44.4	73.4
110.00	SEAT-CENTER INDIVIDUAL 6-PL	0812875 3		1	43.8	73.4
110.10	SEAT-CENTER INDIVIDUAL LEATHER	0812875 3		1	44.4	73.4
110.00	SEAT-FIFTH & SIXTH INDIVIDUAL	0812875 5		1	33.8	108.6
110.10	SEAT-FIFTH & SIXTH INDIVID LTHR	0812875 5		1	34.4	108.6
	CARGO TIE DOWNS-LUGGAGE STD	0812441 1		1	1.5	107.9
110.00	CARGO TIE DOWNS-LUGGAGE 6-PL	0812441 2		1	2.4	109.0
110.10	CARGO TIE DOWNS-LUGGAGE 6-PL	0812441 2		1	2.4	109.0
110.20	CARGO TIE DOWNS-LUGGAGE 6-PL	0812441 2		1	2.4	109.0
310.10	SIDE PANELS-LEATHER	0800301000		1*	2.4	69.0
110.00	ASH TRAY KIT	0800159 1		1	0.5	94.4
102.00	RELIEF TUBE MALE & FEMALE	0812884 1		1	1.8	50.0
110.10	ASH TRAY KIT	0800159 1		1	0.5	94.4
110.00	LIGHT & PLATE ASSYS INSTL	1845		1	0.8	94.5
110.10	LIGHT & PLATE ASSY INSTL	1845		1	0.8	94.5
13.00	MIRROR REAR VIEW	0813680 1		1	0.2	11.5
58.00	CO-PILOT OXYGEN MASK W/MIKE	0800210 2		1	0.1	22.7
123.00	DESK-WRITING RH W/STANDARD SEAT	0819001 1		1	5.4	49.8
123.10	DESK-WRITING RH W/MECH-ELE SEAT	0819001 2		1	5.4	49.8
123.20	DESK-WRITING LH W/STANDARD SEAT	0819001 1		1	5.4	49.8
123.30	DESK-WRITING LH W/MECH-ELE SEAT	0819001 2		1	5.4	49.8
138.70	STEREO TAPE SYSTEM INSTL	0813660 10		1	9.8	31.3
138.80	STEREO HEADSET INSTL	0813660 2		1	1.2	72.6
60.10	OXYGEN SYS (5-PL STD)48.3 CU FT	0800119 19		1	35.8	0.8

SECTION B
STANDARD AND OPTIONAL EQUIPMENT

FACTORY KIT	ITEM	PART NUMBER	MARK IF INSTALLED	QUANTITY	WEIGHT (POUNDS)	ARM (INCHES)
60.40	OXYGEN SYS (4-PL OPT) 48.3 CU FT	0800119 20		1	35.5	0.4
60.20	OXYGEN SYS (6-PL OPT) 48.3 CU FT	0800119 22		1	36.2	2.0
59.10	OXYGEN SYS (5-PL STD) 76.6 CU FT	0800119 19		1	36.2	-0.9
59.40	OXYGEN SYS (4-PL OPT) 76.6 CU FT	0800119 20		1	36.0	-1.3
59.20	OXYGEN SYS (6-PL OPT) 76.6 CU FT	0800119 22		1	36.7	0.3
68.10	OXYGEN PART PLUMBBG SYS (5PL STD	0800119 19		1	2.9	37.2
68.40	OXYGEN PART PLUMBBG SYS (4PL OPT	0800119 20		1	2.7	35.7
68.20	OXYGEN PART PLUMBBG SYS (6PL OPT	0800119 22		1	3.3	46.2
34.00	BAGGAGE DOOR LRG SIZE	0812140 1		1*	10.6	101.1
28.00	CURTAIN-CABIN PRIVACY	0811575 8		1	1.7	58.4
29.00	CURTAIN-SIDE WINDOW	0811791 27		1	2.8	93.3
41.00	NOSE WHEEL FENDER	5042021 1		1	1.0	-48.0
14.00	CARPET-NOSE BAGGAGE AREA	0819008 1		1	2.8	-31.0
199.00	PAINT POLYURETHANE	0800350000		1*	0.0	0.0
	EMERGENCY EQUIPMENT					
37.00	FIRE EXTINGUISHER (HAND TYPE)	5114243 2		1	5.1	35.3
44.00	FIRE EXTINGUISHER (MAGELLE) STC	3018007		1	18.4	16.5
177.00	LOCATOR BEACON ECONOMY	9754037 16		1	2.6	162.7
177.10	LOCATOR BEACON ECONOMY (CAN)	9754037 23		1	2.6	162.7
	AIR COND & ANTI-ICE					
15.00	AIR CONDITIONER, CABIN STC	0800312 1		1	95.1	142.8
67.00	DE-ICE,WING & TAIL-PARTIAL PLBG	0870170 10		1	3.9	57.0
32.00	DE-ICE,WING & TAIL-TOTAL INSTL	0870170 9		1	45.4	70.9
30.00	DE-ICE,PROPELLER 3-BLADE	0870189 9		1	14.3	-17.7
94.10	WINDSHIELD ANTI-ICE SYS,ALCOHOL	0813136 1		1	29.6	90.3
78.00	FUSELAGE ICE PROTECTION PLATES	0813075 1		1	2.8	-25.0

SECTION B
STANDARD AND OPTIONAL EQUIPMENT

FACTORY KIT	ITEM	PART NUMBER	MARK IF INSTALLED	QUANTITY	WEIGHT (POUNDS)	ARM (INCHES)
88.00	HEATED STATIC SOURCE	0814111 2		1	0.3	95.5
88.10	HEATED STATIC SOURCE W/RH INSTR	0814111 1		1	0.3	95.5
73.10	PHOTOGRAPHIC PROVISIONS					
73.20	PHOTOGRAPHIC PROVISIONS-15X23	10-0007 56		1	21.4	93.9
73.30	PHOTOGRAPHIC PROVISIONS-20X27	10-1042 1		1	13.7	89.5
	PHOTOGRAPHIC PROVIS-VIEW FINDER	10-0007 55		1	1.6	94.3

WEIGHT AND BALANCE FORM

PAYLOAD COMPUTATIONS				R E F	ITEM	WEIGHT	MOMENT/ 100
ITEM OCCUPANTS OR CARGO	ARM	WEIGHT	MOMENT/ 100				
1.					BASIC EMPTY WEIGHT		
2.					PAYLOAD		
3.					ZERO FUEL WEIGHT (sub-total) (Do not exceed maximum zero fuel weight)		
4.	Seat 1				FUEL LOADING (main) (auxiliary) (wing lockers)		
	Seat 2						
	Seat 3						
5.	Seat 4				TAKEOFF WEIGHT		
	Seat 5						
	Seat 6						
6.	BAGGAGE				LESS FUEL TO DESTINATION (main) (auxiliary) (wing lockers)		
	PAYLOAD						
7.					LANDING WEIGHT		

SECTION 7

AIRPLANE AND SYSTEMS DESCRIPTIONS

TABLE OF CONTENTS

	Page		Page
INTRODUCTION	7-3	Circuit Breakers and	
AIRFRAME	7-3	Switch Breakers	7-24
INSTRUMENT PANEL	7-3	External Power Receptacle	7-25
Overhead Console	7-5	LIGHTING SYSTEM	7-25
FLIGHT CONTROLS SYSTEM	7-5	External Lighting	7-25
Aileron System	7-6	Internal Lighting	7-27
Aileron Trim System	7-7	PITOT PRESSURE SYSTEM	7-28
Elevator System	7-8	STATIC PRESSURE SYSTEM	7-28
Elevator Trim System	7-9	VACUUM SYSTEM	7-28
Rudder System	7-10	FLIGHT INSTRUMENTS	7-30
Rudder Trim System	7-11	STALL WARNING SYSTEM	7-32
NOSEWHEEL STEERING SYSTEM	7-12	AVIONICS	7-32
WING FLAPS SYSTEM	7-13	Avionics Master Switches	7-32
LANDING GEAR SYSTEM	7-15	ENGINES	7-32
Landing Gear Position		Engine Controls	7-33
Lights	7-16	Engine Oil System	7-33
Landing Gear Warning Horn	7-16	Ignition System	7-34
Landing Gear Handcrank	7-17	Fuel System	7-34
Landing Gear Shock Struts	7-17	Internal Cowl Flap System	7-34
FUEL SYSTEM	7-18	Starting System	7-35
Main Tanks	7-18	Engine Instruments	7-35
Optional Auxiliary		Engine Mounts	7-35
Tanks	7-18	Engine Break-In Procedure	7-35
Optional Wing Locker		HEATING, VENTILATING AND	
Tanks	7-18	DEFROSTING SYSTEM	7-36
Fuel Selectors	7-20	Heating and Defrosting	7-36
Auxiliary Fuel Pump		Cabin Heat Switch	7-36
Switches	7-20	Cabin Air Temperature	
Fuel Drain Valves	7-20	Control Knob	7-36
Fuel Flow Gage	7-20	Forward Cabin Air Knob	7-36
Fuel Quantity Gage	7-21	Cabin Air Knob	7-37
Fuel Low Level Warning		Cabin Heat Registers	7-37
Lights	7-21	Defrost Knob	7-37
Engine-Driven Fuel Pumps	7-21	Heater Overheat Warning	
BRAKE SYSTEM	7-22	Light	7-37
ELECTRICAL SYSTEM	7-22	Heater Operation for	
Battery and Alternator		Heating and Defrosting	7-37
Switches	7-22	Heater Used for Ventila-	
Emergency Alternator		tion	7-39
Field Switch	7-22	Ventilating System	7-39
Overvoltage Relays	7-24	BAGGAGE COMPARTMENTS	7-39
Voltammeter	7-24	Baggage Tie-Down	7-39
		AIRPLANE TIE-DOWN PROVISIONS	
		AND JACK POINTS	7-39

TABLE OF CONTENTS (CONTINUED)

	Page		Page
SEATS, SEAT BELTS AND		Cabin Door	7-40
SHOULDER HARNESSSES	7-40	Windows	7-41
Pilot and Copilot Pro-		Emergency Exit Window	7-41
visions	7-40	CONTROL LOCKS	7-41
Passenger Provisions	7-40	PROPELLERS	7-41
DOORS, WINDOWS AND EXITS	7-40	PROPELLER SYNCHROPHASER	7-42

INTRODUCTION

Section 7 of the Pilot's Operating Handbook provides a description and operation of the airplane and its systems.

NOTE

Operational procedures for optional systems and equipment are presented in Section 9.

AIRFRAME

The 310 is a 4-place (standard), or 6-place (optional), all-metal, low-wing airplane. The fuselage and empennage are of semimonocoque construction. The wing, horizontal and vertical tail surfaces are of conventional aluminum construction. The wing uses 2 main spars which attach to the carry-thru spars. The retractable landing gear is a tricycle design using air-over-oil shock struts.

The 310 II is identical to the 310 except a selection of popular optional equipment has been included as standard equipment.

INSTRUMENT PANEL

The instrument panel, see Figure 7-1, contains the instruments and controls necessary for safe flight. The instrument panel presented is typical, as it contains all standard items and a good selection of popular optional equipment. The function and operation of the instrument panel features not described here have been explained in this section or Section 9 under the applicable system.

INSTRUMENT PANEL

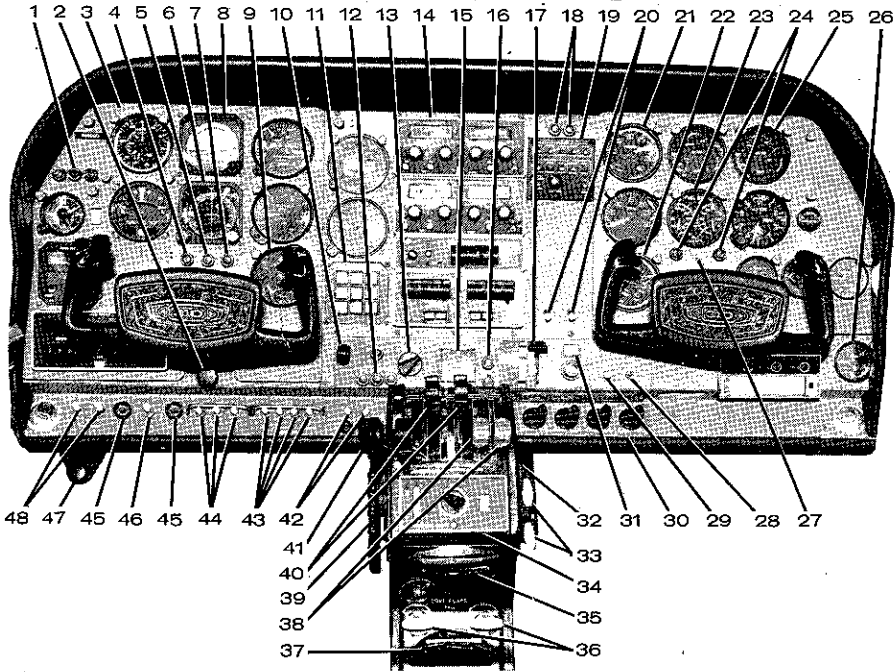

- | | |
|--|---|
| 1. MARKER BEACON INDICATOR LIGHTS (OPTIONAL) | 22. FUEL FLOW GAGE |
| 2. OXYGEN CONTROL | 23. FUEL QUANTITY GAGE |
| 3. FLIGHT INSTRUMENT GROUP | 24. AUXILIARY FUEL TANK LIGHTS |
| 4. WING DEICE PRESSURE LIGHT (OPTIONAL) | 25. COMBINATION ENGINE GAGE |
| 5. TURN AND BANK LIGHT | 26. OXYGEN CYLINDER PRESSURE GAGE |
| 6. FLIGHT DIRECTOR HSI (OPTIONAL) | 27. FUEL QUANTITY SELECTOR SWITCH |
| 7. LOW VOLT LIGHT | 28. CABIN HEATER OVERHEAT LIGHT |
| 8. FLIGHT DIRECTOR FDI (OPTIONAL) | 29. CABIN HEATER SWITCH |
| 9. ECONOMY MIXTURE INDICATOR (OPTIONAL) | 30. CABIN AIR CONTROL PANEL |
| 10. LANDING GEAR SWITCH | 31. CABIN STEP AND WING WALKWAY LIGHT SWITCH (OPTIONAL) |
| 11. FLIGHT DIRECTOR MODE SELECTOR (OPTIONAL) | 32. QUADRANT FRICTION LOCK |
| 12. LANDING GEAR POSITION INDICATOR LIGHTS | 33. ALTERNATE AIR CONTROLS |
| 13. AMP METER SELECT SWITCH | 34. AUTOPILOT CONTROL HEAD (OPTIONAL) |
| 14. AVIONICS CONTROL PANEL | 35. RUDDER TRIM CONTROL |
| 15. VOLTAMMETER | 36. COWL FLAP CONTROLS |
| 16. ALTERNATOR FAILURE LIGHTS | 37. AILERON TRIM CONTROL |
| 17. FLAP POSITION SWITCH | 38. MIXTURE CONTROLS |
| 18. FUEL LOW LEVEL LIGHTS (OPTIONAL) | 39. ELEVATOR TRIM CONTROL |
| 19. 300 AUDIO SWITCHING PANEL (OPTIONAL) | 40. PROPELLER CONTROLS |
| 20. AIR CONDITIONING SWITCHES (OPTIONAL) | 41. THROTTLE CONTROLS |
| 21. MANIFOLD PRESSURE GAGE | 42. FUEL TRANSFER SWITCHES |
| | 43. MAGNETO SWITCHES |
| | 44. BATTERY AND ALTERNATOR SWITCHES |
| | 45. ENGINE START SWITCHES |
| | 46. ENGINE PRIME SWITCH |
| | 47. PARKING BRAKE CONTROL |
| | 48. AUXILIARY FUEL PUMP SWITCHES |

Figure 7-1

OVERHEAD CONSOLE

The overhead console, see Figure 7-2, includes the avionics speaker, instrument panel floodlight with dimming control, oxygen jacks for the pilot and copilot, and a headphone and microphone jack.

OVERHEAD CONSOLE

Figure 7-2

FLIGHT CONTROLS SYSTEM

The flight controls consist of the ailerons, elevators and rudder and their respective trim systems. All of these surfaces are constructed of aluminum and are 100% statically mass balanced.

AILERON SYSTEM

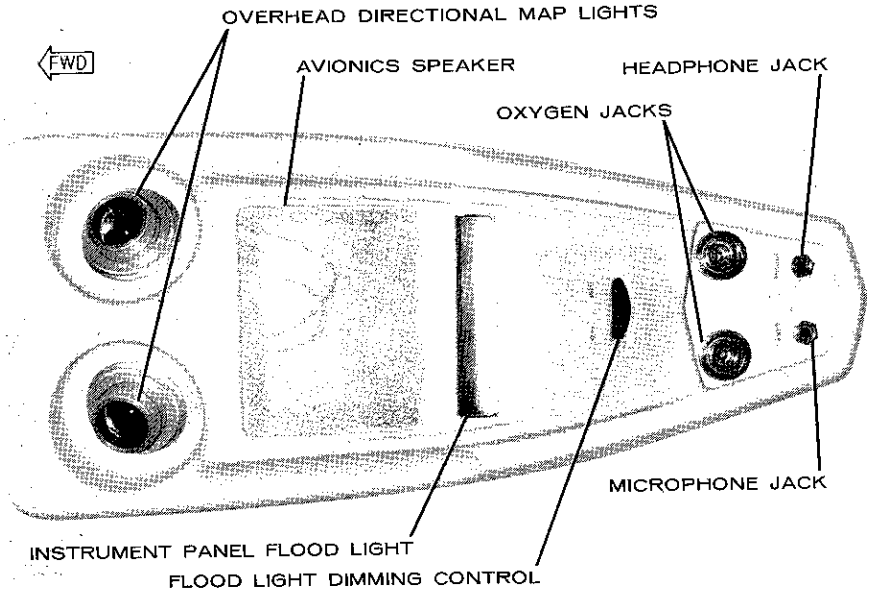
Each aileron, see Figure 7-3, is attached to the rear main wing spar at two points. The aileron is actuated by a push-pull rod which is attached to a bell crank in the wing. The bell crank is actuated by cables attached to the pilot's control wheel.

AILERON SYSTEM

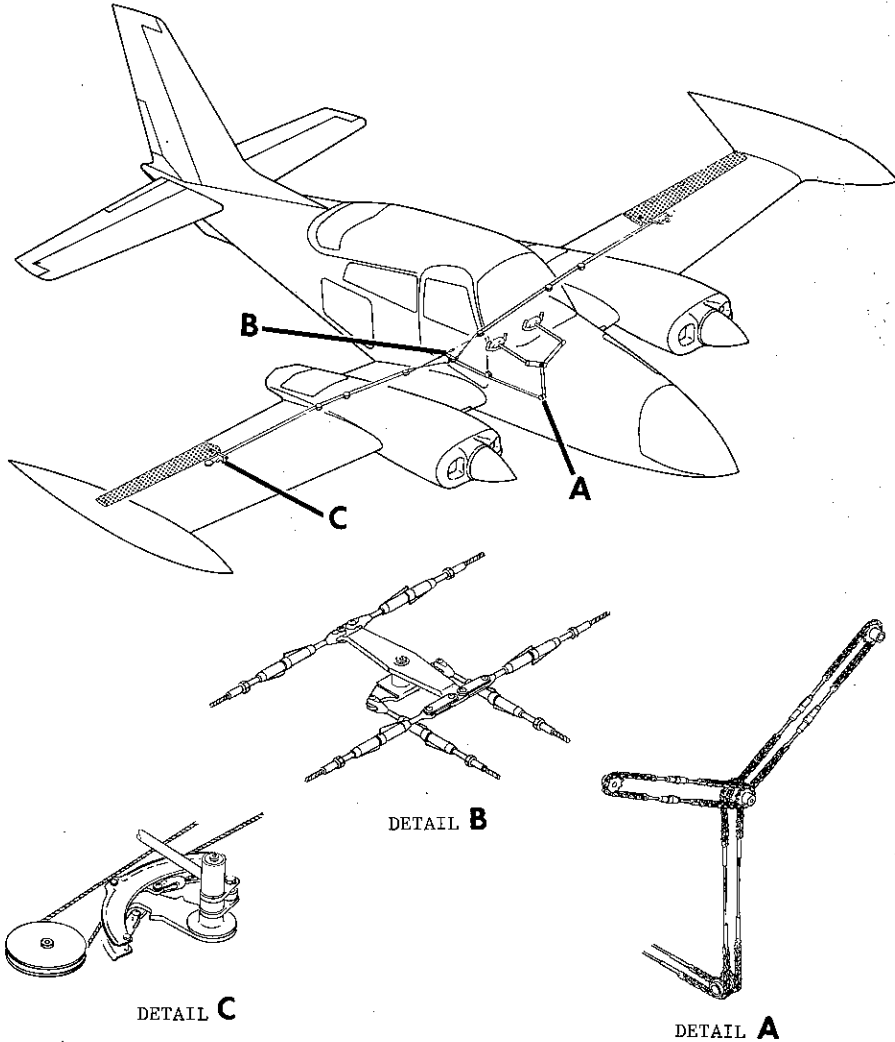

Figure 7-3

AILERON TRIM SYSTEM

Aileron trim, see Figure 7-4, is achieved by a trim tab attached to the left aileron with a full length piano-type hinge. The trim tab is actuated by a push-pull rod which is attached to a jack screw type actuator in the wing. The actuator is driven by cables attached to the trim control knob on the cockpit control pedestal.

AILERON TRIM SYSTEM

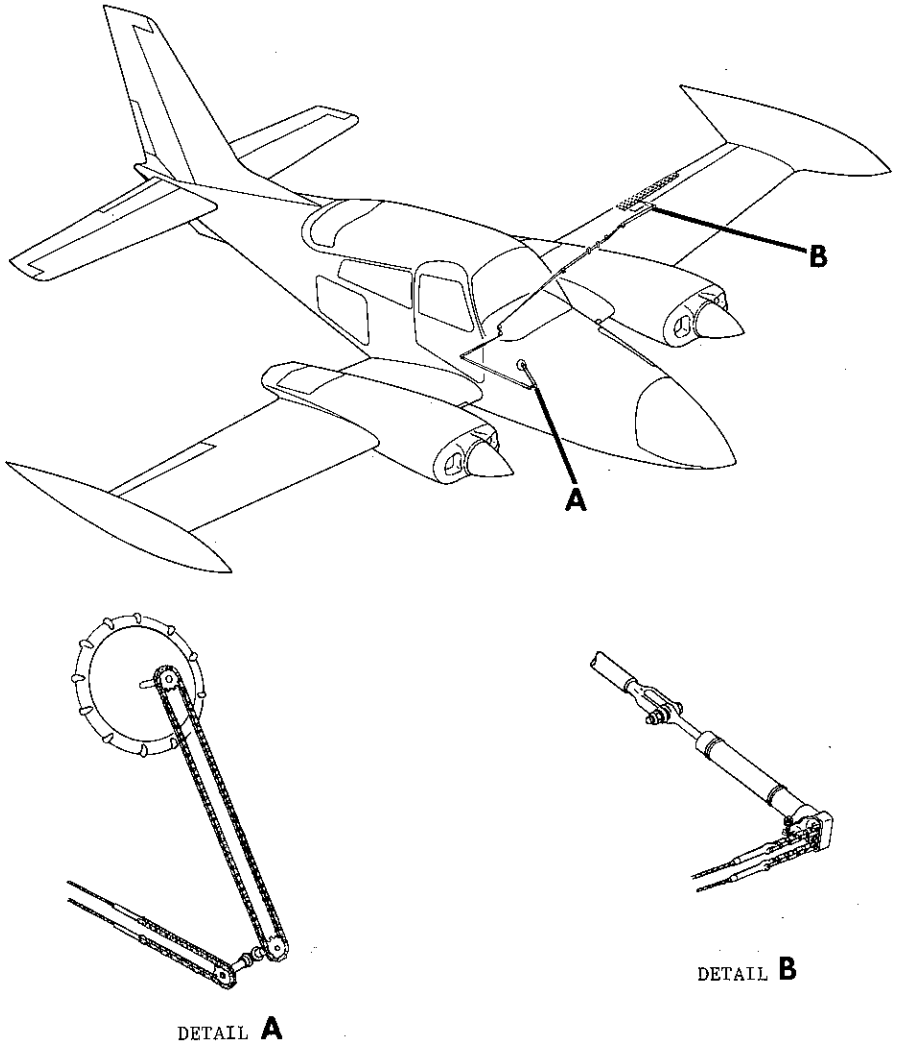

Figure 7-4

ELEVATOR SYSTEM

The two elevator control surfaces, see Figure 7-5, are connected by a torque tube. The resulting elevator assembly is attached to the rear spar of the horizontal stabilizer at five points. The elevator assembly is actuated by a push-pull rod which is attached to a bell crank in the empennage. The bell crank is actuated by cables attached to the pilot's control wheel.

ELEVATOR SYSTEM

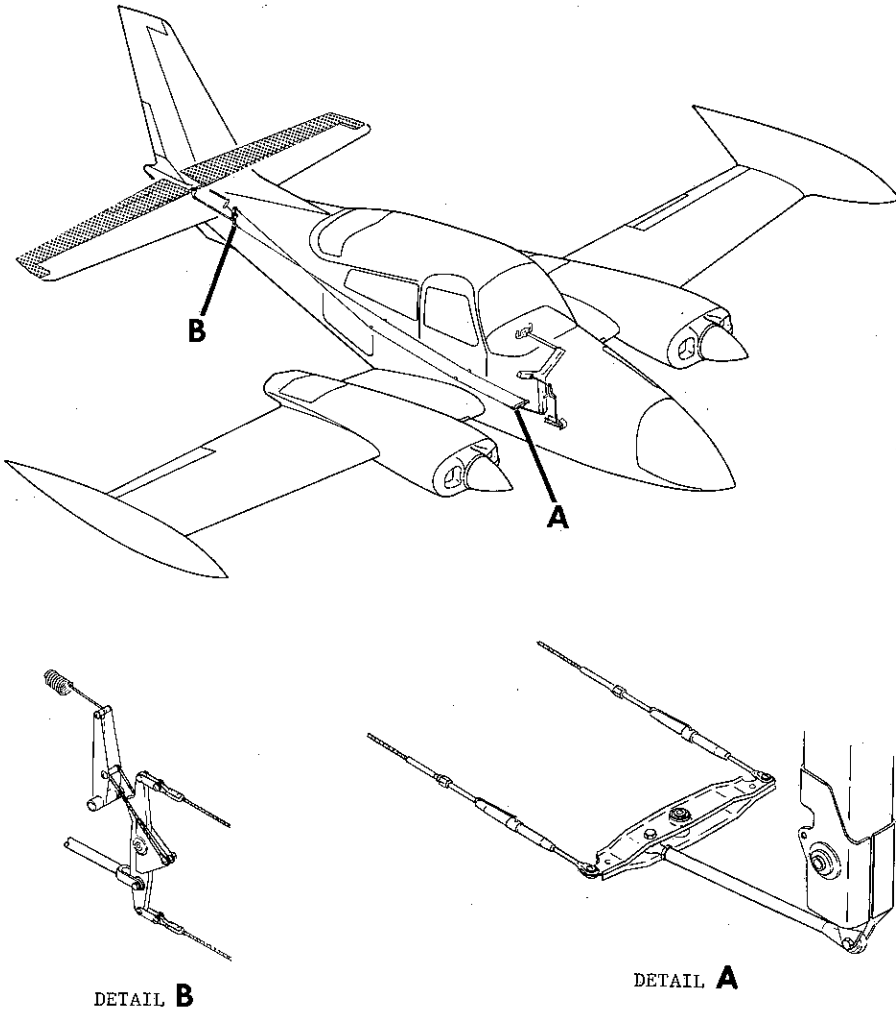

Figure 7-5

ELEVATOR TRIM SYSTEM

Elevator trim, see Figure 7-6, is achieved by an elevator trim tab attached to the right elevator with a full length piano-type hinge. The trim tab is actuated by a push-pull rod which is attached to a jack screw type actuator in the horizontal stabilizer. The actuator is driven by cables attached to the trim control wheel on the cockpit control pedestal.

ELEVATOR TRIM SYSTEM

Figure 7-6

RUDDER SYSTEM

The rudder, see Figure 7-7, is attached to the vertical stabilizer rear main spar at three points. The rudder is actuated by a bell crank attached to the bottom of the rudder. The bell crank is actuated by cables attached to the cockpit rudder pedals.

RUDDER SYSTEM

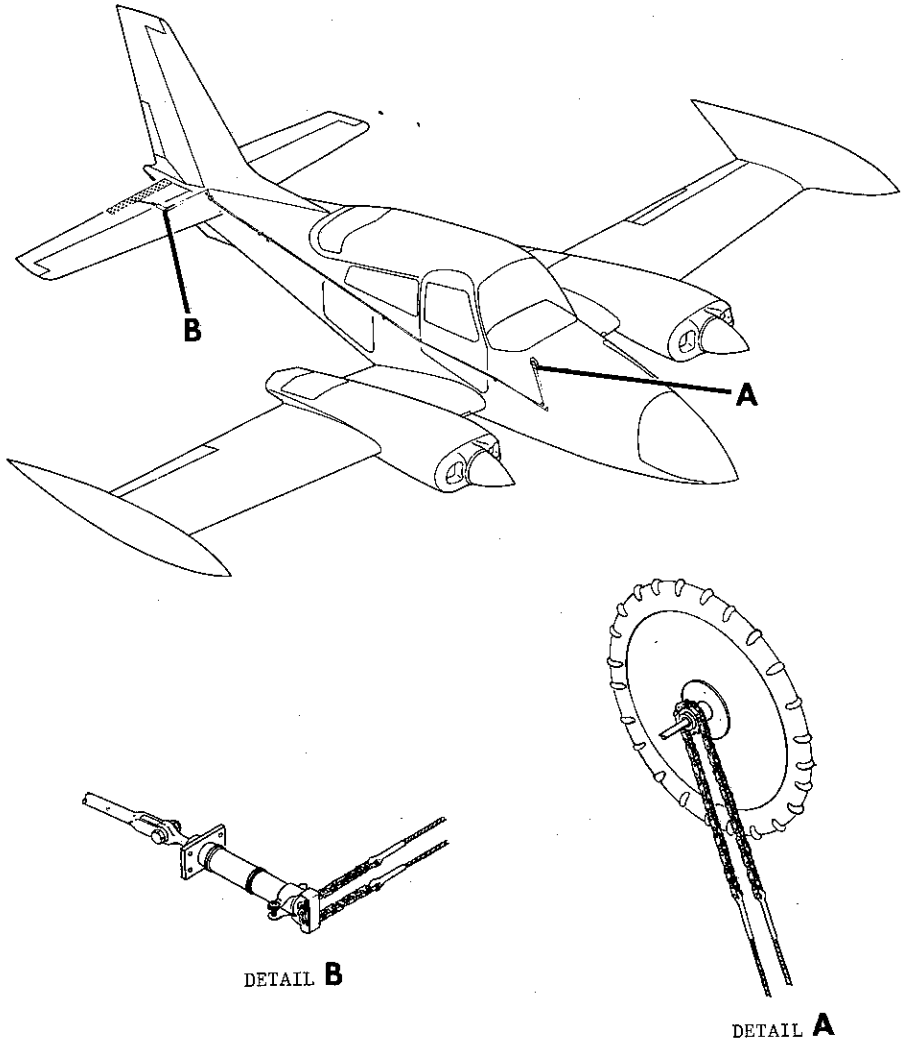
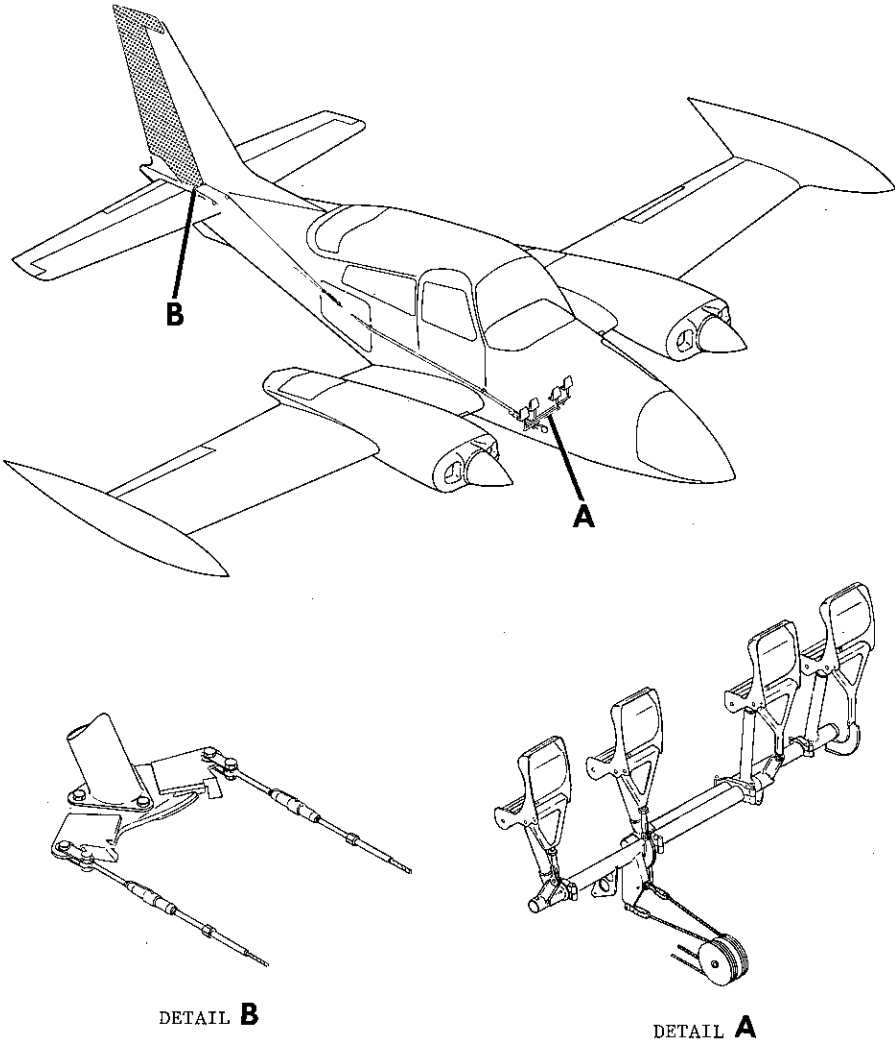

Figure 7-7

RUDDER TRIM SYSTEM

Rudder trim, see Figure 7-8, is achieved by a trim tab attached to the lower half of the rudder with a full length piano-type hinge. The trim tab is actuated by a push-pull rod which is attached to a jack screw type actuator in the vertical stabilizer. The actuator is driven by cables attached to the rudder trim wheel on the cockpit control pedestal.

RUDDER TRIM SYSTEM

Figure 7-8

NOSEWHEEL STEERING SYSTEM

The nosewheel steering system, see Figure 7-9, consists of the rudder pedals, nose gear, bungee spring assembly and cables. During ground operation, the nose gear automatically engages the nosewheel steering system, allowing normal directional control.

NOSEWHEEL STEERING SYSTEM

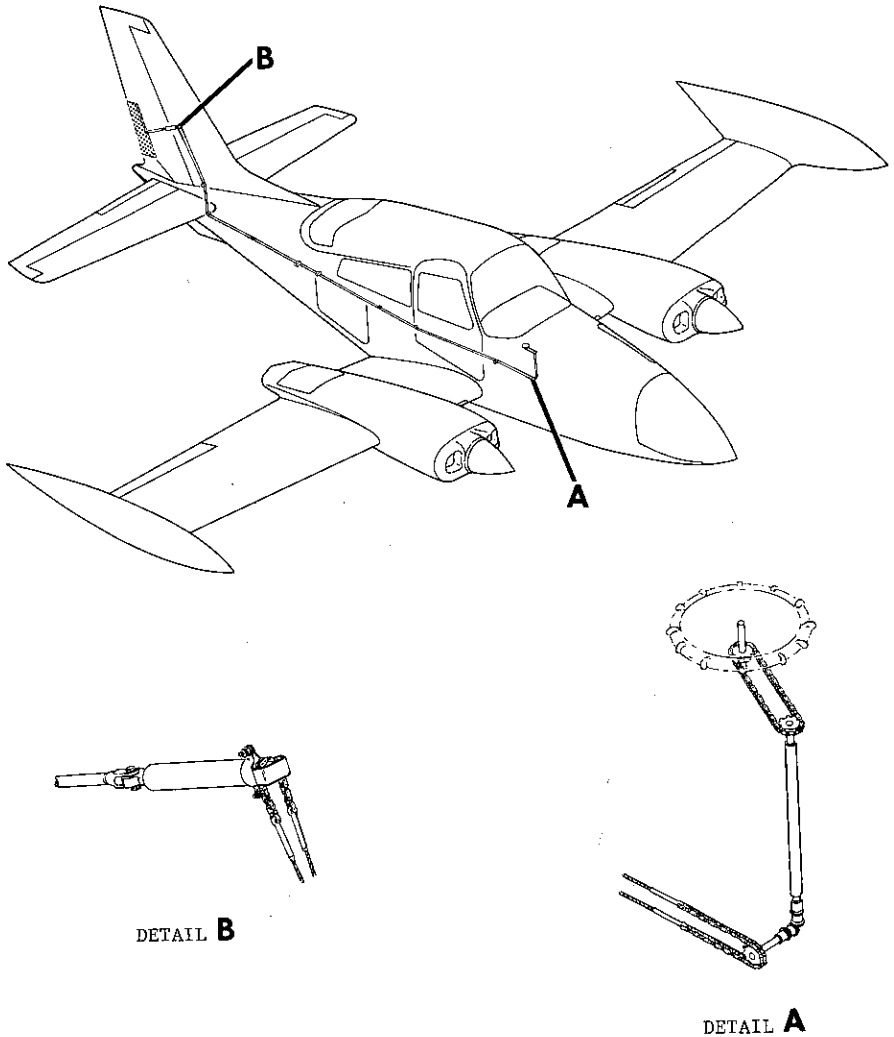
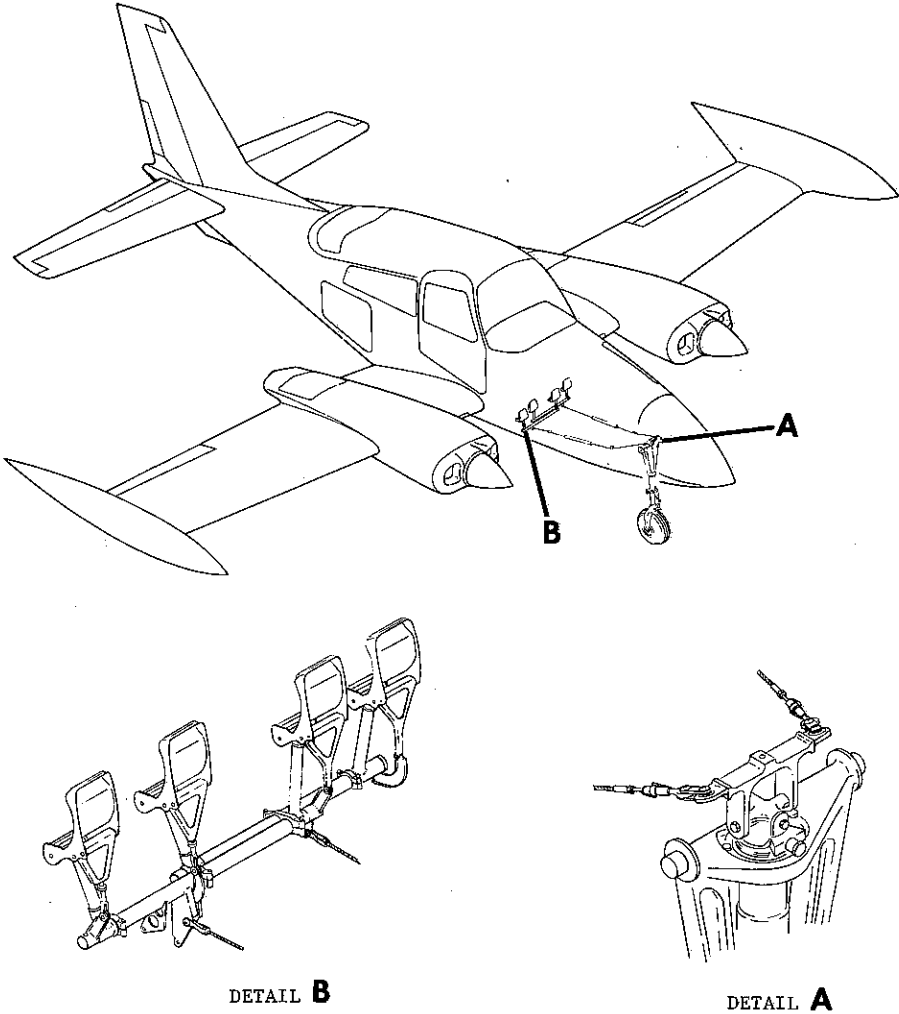

Figure 7-9

The minimum turning radius is presented in Figure 7-10. Always use as large a radius of turn as is practical. Turning tighter than necessary requires excessive braking on the inboard wheel which decreases the tire life.

NOTE

Minimum turning radius is effected with inboard wheel brake locked, full rudder and differential power.

MINIMUM TURNING RADIUS

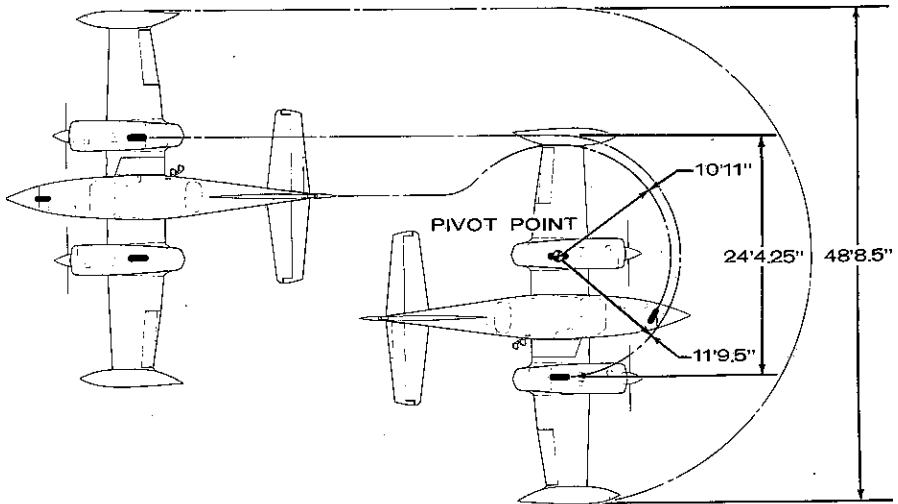

Figure 7-10

WING FLAPS SYSTEM

The wing flaps, see Figure 7-11, are of the split flap design. Each wing flap (two per side) is attached to the rear wing main spar lower surface and is actuated by two push-pull rods attached to bell cranks in the wing. The bell cranks in each wing are ganged together with push-pull rods. Each inboard push-pull rod is attached to a cable which is actuated by an electric motor with reduction gear in the fuselage center section.

The electric flap motor is controlled by the wing flap position switch, see Figure 7-1, in the cockpit. This switch incorporates a preselect

feature which allows the pilot to select the amount of flap extension desired. When the 0°, 15° or 35° position is selected, the flap motor is electrically actuated and drives the flaps toward the selected position. As the flaps move, an intermediate cable feeds position information back to the preselect assembly. When the actual flap position equals the selected position, a microswitch deenergizes the flap motor.

WING FLAPS SYSTEM

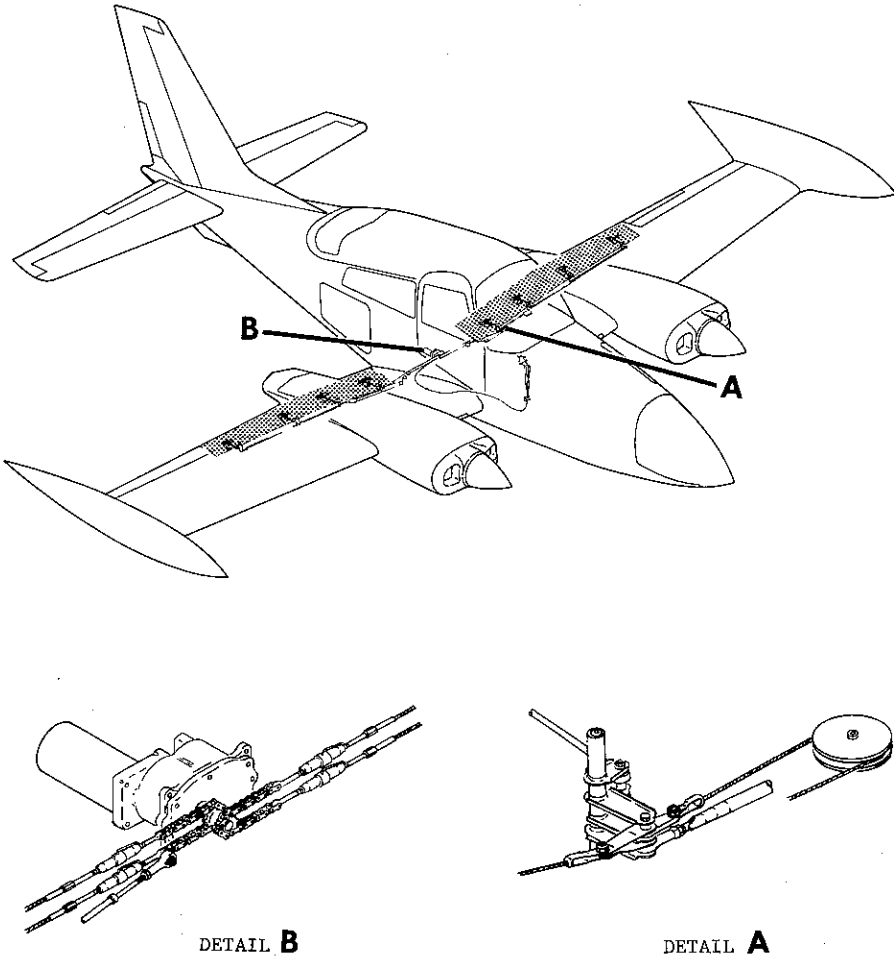

Figure 7-11

LANDING GEAR SYSTEM

The landing gear, see Figure 7-12, is a fully retractable tricycle landing gear consisting of a main gear located in each wing and a nose gear located in the forward fuselage. Each landing gear is mechanically connected to a single gear box located aft of the pilot's seat. The single gear box is normally driven electrically by a motor attached to the gear box. The electric motor is actuated by the landing gear switch on the pilot's instrument panel. During ground operation, accidental gear retraction, regardless of gear switch position, is prevented by a safety switch located on the left landing gear shock strut. When the weight of the airplane is on the landing gear, the shock strut is compressed, allowing the safety switch to open, thus preventing electrical power from reaching the landing gear motor.

The landing gear doors are mechanically linked to their respective landing gears, retracting and extending with each landing gear.

The landing gear is operated by a switch, see Figure 7-1, which is identified by a wheel-shaped knob. The switch positions are UP, off (center) and DOWN. To operate the gear, pull out the landing gear switch and move to the desired position. This allows electrical power to energize the landing gear motor, driving the landing gear toward the selected position. The motor will continue to run until the up or down limit switch on the gear box disconnects the electrical power to the landing gear motor.

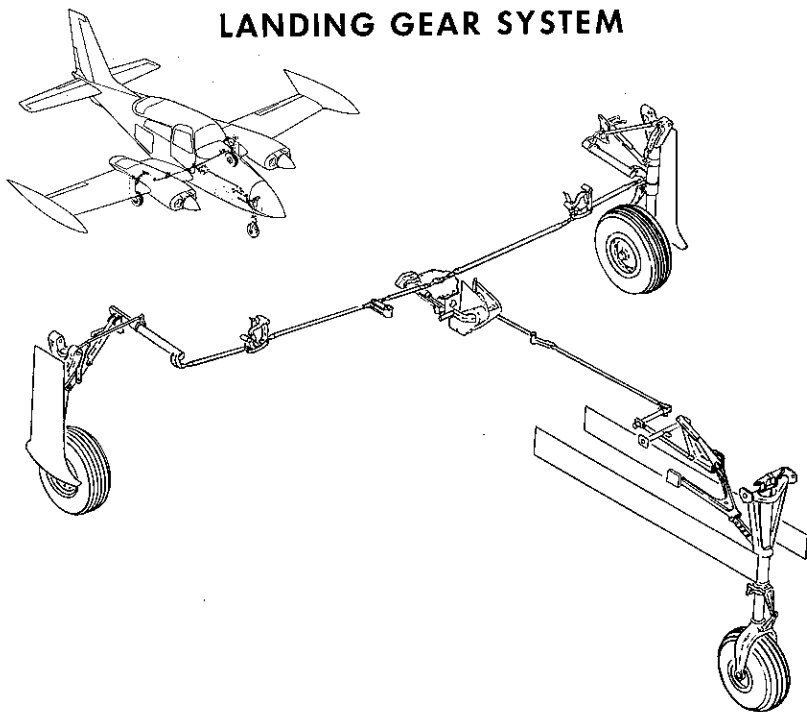

Figure 7-12

LANDING GEAR POSITION LIGHTS

Four landing gear position indicator lights, see Figure 7-1, are located to the right of the landing gear switch. Three of these lights (one for each gear) are green and will illuminate when each landing gear is fully extended and locked. The other light is red and will illuminate when any or all of the gears are unlocked (intermediate position). When the gear unlocked light and gear down lights are not illuminated, the landing gear is in the UP and locked position. The lights are push-to-test type with rotatable dimming shutters.

NOTE

The rotatable dimming shutters must be turned to full bright during daylight operations to insure adequate illumination of the landing gear position indicator lights.

LANDING GEAR WARNING HORN

The landing gear warning horn is controlled by the throttles and the wing flap position. The warning horn will sound intermittently if either throttle is retarded below approximately 12.0 inches Hg. manifold pressure with the landing gear retracted or if the wing flaps are lowered past the 15° position with the landing gear in any position except extended and locked. The warning horn can be activated by either the wing flap position switch or by throttle position as each functions independently of the other. The warning horn is also connected to the UP position of the landing gear position switch and will sound if the switch is placed in the UP position while the airplane is on the ground.

NOTE

Do not pull landing gear warning circuit breaker to silence horn as this turns off the landing gear control relay, thus the landing gear cannot be retracted.

LANDING GEAR HANDCRANK

A landing gear handcrank, see Figure 7-13, for manually lowering the landing gear, is located just below the right front edge of the pilot's seat. Normally, the crank is folded and stowed in a clip beside the seat. To use the crank, tilt pilot's seat aft, pull the crank out from its storage clip and unfold it until it locks in the operating position. The procedure for manually lowering the landing gear is given in Section 3. To stow the crank, push the lock release button on the crank handle, fold the handle and insert it in the storage clip.

NOTE

The handcrank handle must be stowed in its clip before the gear will operate electrically. When the handle is placed in the operating position, it disengages the landing gear motor from the actuator gear.

LANDING GEAR HANDCRANK

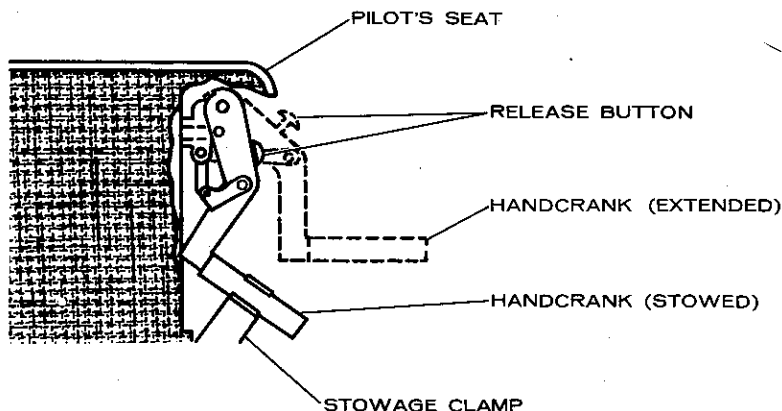

Figure 7-13

LANDING GEAR SHOCK STRUTS

Shock absorption is provided on each gear by an air-over-oil shock strut. This strut is composed of two basic parts: an upper trunnion assembly and a lower piston assembly which fits inside the upper trunnion assembly. The lower piston assembly contains an orifice and tapered metering pin which vary the resistance to shock according to severity transmitted to the upper trunnion assembly.

FUEL SYSTEM

The fuel system, see Figure 7-14, consists of two main tanks, two optional auxiliary tanks, two optional wing locker tanks, fuel selectors for selection of main, auxiliary or crossfeed fuel and other necessary components to complete the system.

MAIN TANKS

The main tanks are integrally sealed (wet) aluminum tanks mounted on each wing tip. Each tank contains an auxiliary fuel pump and transfer pump. The auxiliary fuel pump, mounted in the bottom of the tank, provides fuel pressure for priming during engine starting and supplies fuel to the engine in an emergency. The auxiliary pump operation is controlled by an auxiliary fuel pump switch on the switch and circuit breaker panel. The transfer pump, mounted on the aft side of the main tank rear bulkhead, transfers fuel from the nose section of the main tank to the center sump area, where it is picked up and routed to the engine by the engine-driven or auxiliary fuel pump. The transfer pump permits steep descents with low main tank fuel quantity. The transfer pump operates continuously whenever the battery switch is positioned to ON. The main tank is vented to atmospheric pressure by a flush vent located on the lower aft portion of the main tank. These tanks are serviced through a flush filler located on the top forward portion of each tank.

OPTIONAL AUXILIARY TANKS

The optional auxiliary tanks are available in two sizes. These tanks are bladder-type cells located between the spars in the outboard wing. These tanks provide an engine fuel supply during cruise operations. The auxiliary tanks are vented to the main tanks. The auxiliary tanks are serviced through a flush filler located on the upper wing surface outboard of the nacelles.

OPTIONAL WING LOCKER TANKS

A wing locker fuel tank is available for installation in the forward portion of each wing locker baggage area. These tanks are bladder-type cells which supplement the main tank fuel quantity. This fuel cannot be fed directly to the engines; instead it is transferred to the main tanks by wing locker fuel transfer pumps. The transfer pumps are manually controlled and should not be energized until adequate volume is available in the main tanks to hold the wing locker fuel. After the fuel is transferred, a pressure switch in each transfer line will sense a drop in pressure and illuminate the indicator light on the instrument panel, indicating fuel transfer is complete and the applicable wing locker transfer pump should be turned off. These pumps use fuel for lubrication; therefore, operation after fuel transfer will shorten the pump life. The wing locker fuel tanks are individually vented through the lower surface of each wing. The fuel vent lines are deiced by heaters which are controlled by the pitot heat switch. These tanks are serviced through a flush filler located on the top of the engine nacelle.

FUEL SYSTEM

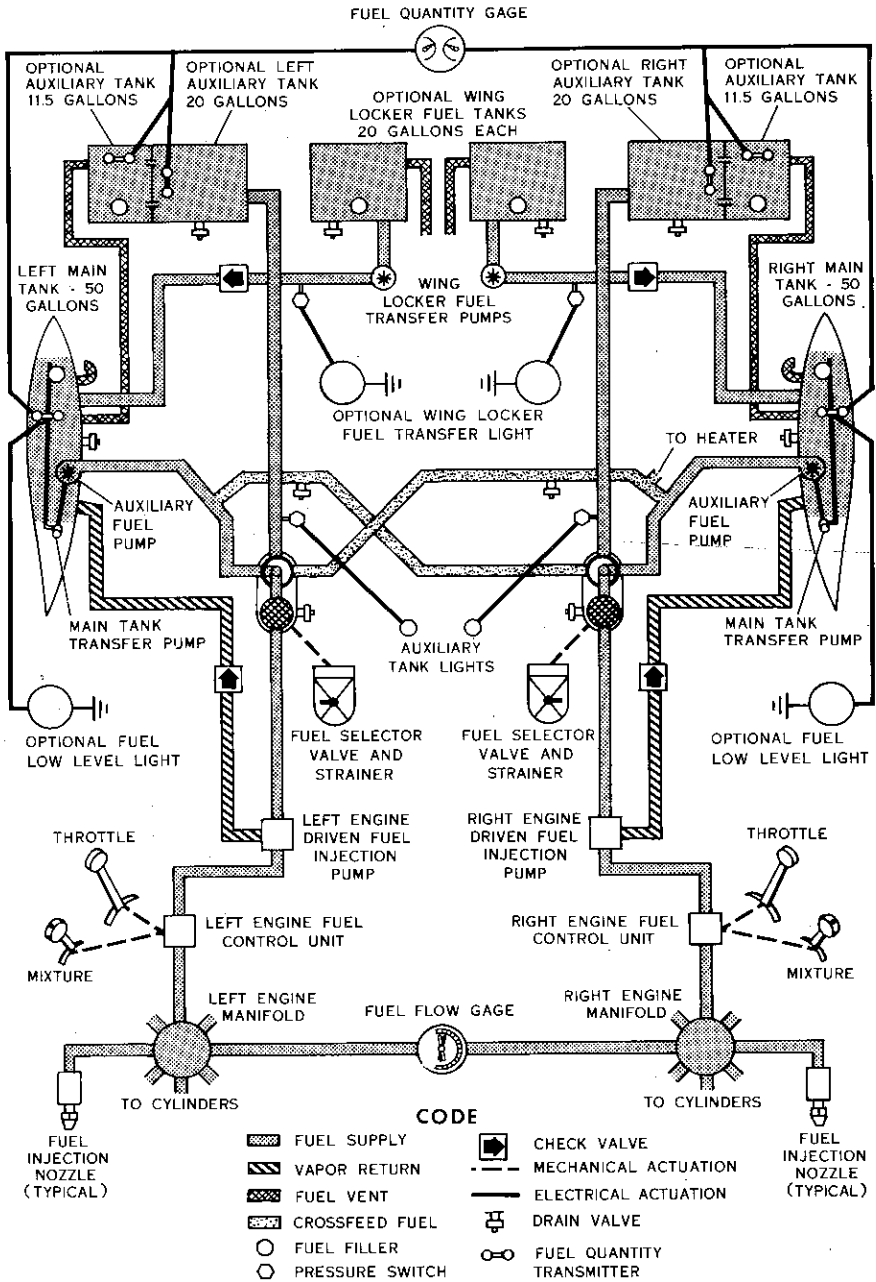

Figure 7-14

FUEL SELECTORS

Two fuel selectors, one for each engine, are provided on the floor between the pilot and copilot seats. The selectors allow selection of main fuel, auxiliary fuel, crossfeed and no fuel.

The MAIN position of each selector allows fuel to flow from the main tank through the fuel selector to the engine-driven fuel pump. The AUXILIARY position allows fuel to flow from the auxiliary tank through the fuel selector to the engine-driven pump. The crossfeed position allows fuel to flow from the opposite engine main tank to the engine-driven fuel pump. The crossfeed position is used for balancing asymmetric fuel loads and supplying the engine-driven fuel pump from the opposite main tank. When the OFF position is selected, no fuel is allowed to flow to the engine-driven fuel pump.

The fuel selector handles form the pointers for the selectors. The ends of the handles are arrow-shaped and point to the position on the selector placard which corresponds to the valve position.

AUXILIARY FUEL PUMP SWITCHES

A 3-position auxiliary fuel pump switch, see Figure 7-1, is provided for each main fuel tank pump. In the LOW position, the auxiliary fuel pumps operate at low speed, providing adequate fuel flow for purging. The ON position runs the auxiliary fuel pumps at low speed, as long as the engine-driven pumps are functioning. With an engine-driven pump failure and the switch in the ON position, the auxiliary pump on that side will switch to high speed automatically, providing sufficient fuel for all partial-power engine operations.

FUEL DRAIN VALVES

Fuel quick-drain valves are provided for each fuel tank, fuel selector and crossfeed line. In addition, a quick-drain is provided in each wing locker fuel transfer line. The drains provide a location for removing moisture and sediment from the fuel system. The drains are located on the lower surface of the fuselage, wing and main tanks and are actuated by depressing the lower portion of the valve. A special screwdriver is provided with the airplane which allows a 2-ounce sample to be drained and inspected without fuel spillage.

FUEL FLOW GAGE

The fuel flow gage, see Figure 7-1, is a dual instrument which indicates the approximate fuel consumption of each engine in pounds per hour. The fuel flow gage used with the injection system senses the pressure at which fuel is delivered to the engine spray nozzles. Since fuel pressure at this point is approximately proportional to the fuel consumption of the engine, the gage is marked as a flowmeter.

The gage dial is marked with arc segments corresponding to proper fuel flow for various power settings and is used as a guide to quickly set the mixtures. The gage has markings for takeoff and climb, and cruise power settings for various altitudes.

The takeoff and climb markings are the recommended full power fuel flows (2700 RPM and full throttle) for altitudes from sea level to 6000 feet. The sea level mark is a white arc while the marks for 2000, 4000 and 6000 feet are blue. Recommended fuel flows for altitudes above 6000 feet are presented in Section 5. Cruise climbs at 24.5 Inches Hg. manifold pressure and 2500 RPM should be conducted at a fuel flow of 107 pounds per hour per engine (75% power blue triangle) up to 5200 feet. Recommended fuel flows for altitudes above 5200 feet are presented in Section 5. In the cruise power range, standard day recommended lean fuel flows are presented as green segments.

FUEL QUANTITY GAGE

The dual indicating fuel quantity gage, see Figure 7-1, is calibrated in pounds and will accurately indicate the weight of fuel contained in the tanks; however, fuel density varies with temperature, therefore a full tank will weigh more on a cold day than on a warm day. This will be reflected by the weight shown on the gage. A gallons scale is provided in blue on the indicator for convenience in allowing the pilot to determine the approximate volume of fuel on board.

The dual indicating fuel quantity gage continuously indicates fuel remaining in the tanks selected. When the fuel selectors are in the AUX position, auxiliary tank indicator lights, see Figure 7-1, will illuminate and the fuel quantity gage will indicate the fuel in the auxiliary tanks (pounds in white and gallons in blue). When the fuel selectors are in the MAIN position, the fuel quantity gage will indicate the fuel in the main tanks. A 3-position switch, spring-loaded to center, allows checking fuel quantity in the tanks not selected. The switch, adjacent to the auxiliary tank indicator lights, is labeled MAIN and AUX. By positioning the switch to the appropriate tank position, the fuel quantity in that tank will be indicated on the fuel quantity gage.

FUEL LOW LEVEL WARNING LIGHTS

The optional fuel low level warning lights, see Figure 7-1, provide a warning when the left and/or right main tanks contain approximately 60 pounds of fuel. The warning is provided by two fuel low level warning lights located at the top of the avionics control panel. These lights are actuated by a float switch located in each main fuel tank. Each light operates independently from the fuel quantity indicating system.

ENGINE-DRIVEN FUEL PUMPS

Each engine is equipped with a mechanically driven fuel pump which provides fuel to the metering unit. Each pump also contains a bypass which returns excess fuel and vapor to the main tanks at all times. Should these pumps fail, the main tank auxiliary pumps can provide sufficient fuel flow for all partial-power engine operations. These auxiliary pumps, however, operate at a fixed pressure, consequently the mixture must be leaned when operating at a low power setting to prevent flooding the engine. Conversely, if an engine-driven pump failure should occur during high power operation, adequate fuel flow may not be available to insure rated power and adequate engine cooling.

BRAKE SYSTEM

The airplane is provided with an independent hydraulically actuated brake system for each main wheel. A hydraulic master cylinder is attached to each pilot's rudder pedal. Hydraulic lines and hoses are routed from each master cylinder to the wheel cylinder on each brake assembly. No manual adjustment is necessary on these brakes. The brakes can be operated from either pilot's or copilot's pedals. The parking brake system consists of a manually operated handle assembly, see Figure 7-1, connected to the parking brake valves located in each main brake line. When pressure is applied to the brake system and the parking brake handle is pulled, the valve holds pressure on the brake assemblies until released. To release parking brakes, push the parking brake handle in. It is not necessary to depress the rudder pedals when releasing the parking brake.

Maximum braking effectiveness is obtained by applying full even pressure to the toe brakes and applying full back pressure to the control column. This procedure is recommended only for emergency stops as excessive brake pad wear will occur. Maximum brake wear occurs at high speed. This brake wear can be reduced using aerodynamic braking supplemented with the use of wheel brakes. Maximum aerodynamic braking occurs with wing flaps extended to 35° and control wheel held aft to keep the nose off the runway as long as possible.

ELECTRICAL SYSTEM

Electrical energy, see Figure 7-15, is supplied by a 28-volt, negative-ground, direct current system powered by an alternator on each engine. The electrical system has independent circuits for each side with each alternator having its own regulator and overvoltage protection relay. The voltage regulators are connected to provide proper load sharing. A 24-volt battery is located in the left wing just outboard of the engine nacelle. Immediate detection of low system voltage is provided by a LOW VOLT light on the instrument panel, see Figure 7-1. The light will illuminate when the airplane bus voltage decreases below approximately 25 volts.

BATTERY AND ALTERNATOR SWITCHES

Separate battery and alternator switches, see Figure 7-1, are provided as a means of checking for a malfunctioning alternator circuit and to permit such a circuit to be turned off. If an alternator circuit fails or malfunctions, or when one engine is not running, the switch for that alternator should be turned off. Operation should be continued on the functioning alternator, using only necessary electrical equipment. If both alternator circuits should malfunction, equipment can be operated at short intervals on the battery alone. In either case a landing should be made as soon as practical to check and repair the circuits.

EMERGENCY ALTERNATOR FIELD SWITCH

An emergency alternator field switch, see Figure 7-16, is located on the right side of the switch and circuit breaker panel. The switch is used when the alternators will not self-excite. Placing the switch in the ON position provides excitation from the battery even though the battery is considered to have failed.

ELECTRICAL SYSTEM

TO AIRPLANE SYSTEMS

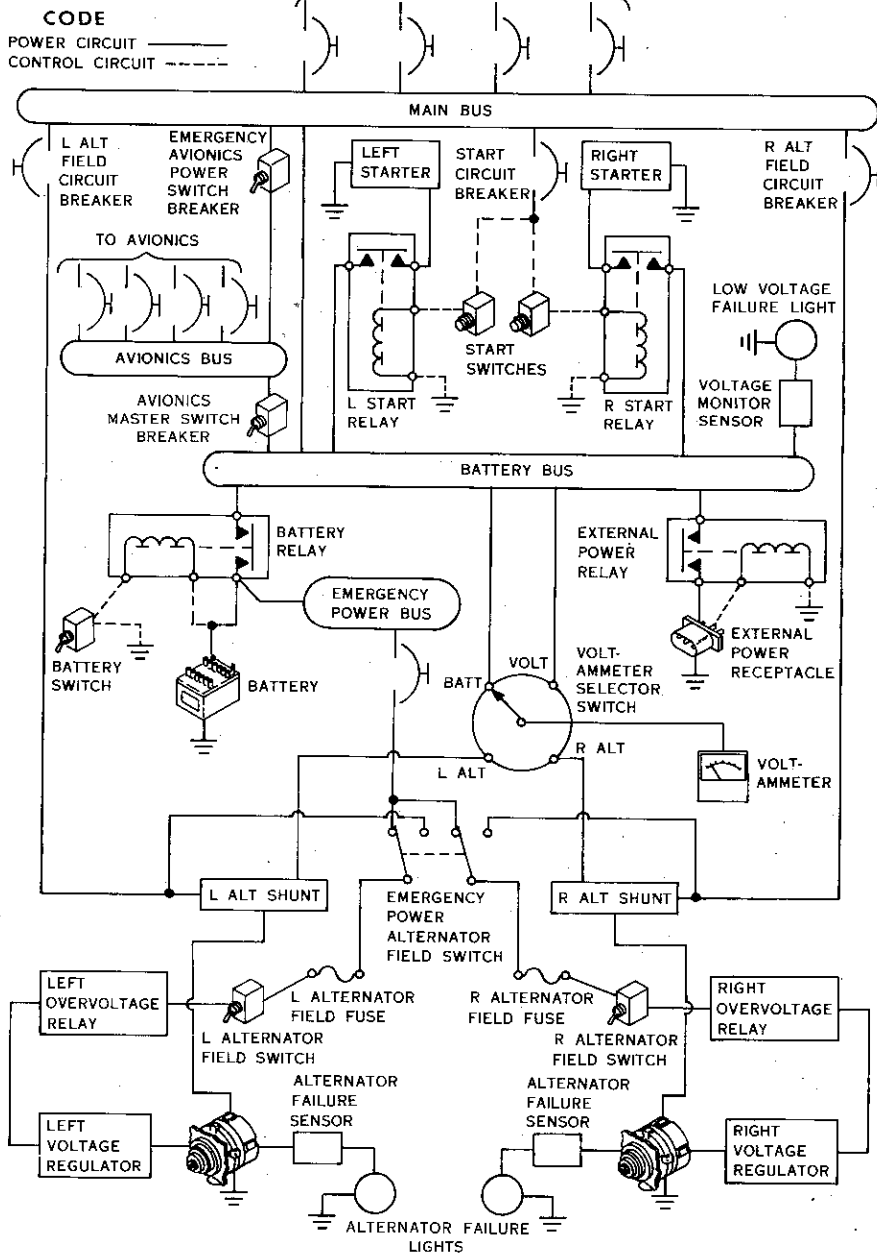

Figure 7-15

SWITCH AND CIRCUIT BREAKER PANEL

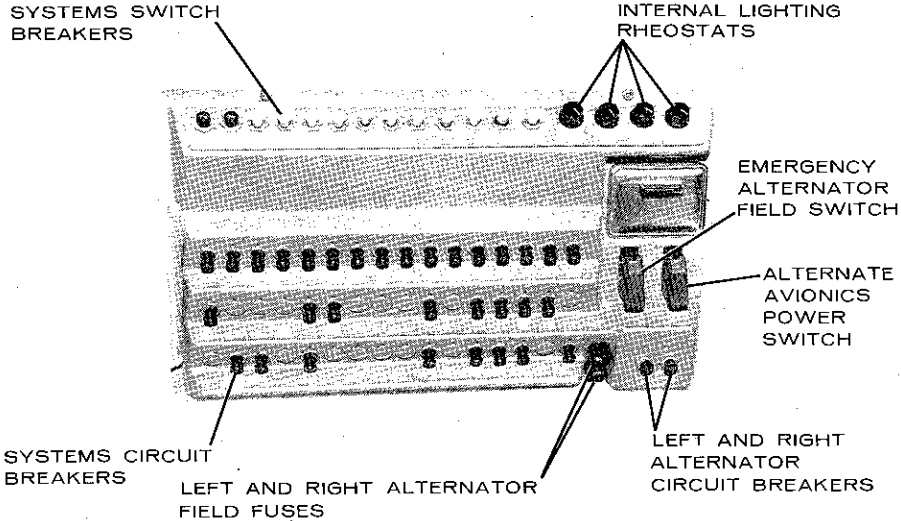

Figure 7-16

OVERVOLTAGE RELAYS

Two overvoltage relays in the electrical system constantly monitor their respective alternator output. Should an alternator exceed the normal operating voltage, the overvoltage relay will trip, taking the affected alternator off the line. The overvoltage relay can be reset by cycling the applicable alternator switch.

VOLTTMETER

A voltmeter, see Figure 7-1, located on the instrument panel is provided to monitor alternator current output, battery charge or discharge rate and bus voltage. An AMP METER SELECT switch, see Figure 7-1, labeled L ALT, R ALT, BAT, and VOLTS is located to the left of the voltmeter. By positioning the switch to L ALT, R ALT, or BAT position, the respective alternator or battery amperage can be monitored. By positioning the switch to the VOLTS position, the electrical system bus voltage can be monitored.

CIRCUIT BREAKERS AND SWITCH BREAKERS

All electrical systems in the airplane are protected by push-to-reset type circuit breakers or switch breakers, see Figure 7-16. Should an overload occur in any circuit, the resulting heat rise will cause the controlling circuit breaker to "pop" out, opening the circuit or allowing the switch breaker to return to the OFF position. After allowing to cool for approximately three minutes, the circuit breaker may be pushed in (until a click is heard or felt) or the switch breaker may be returned to the ON position to reenergize the circuit. However, the circuit should not be held in nor the switch breaker forced to remain in the ON position if it opens the circuit a second time as this indicates a short circuit.

EXTERNAL POWER RECEPTACLE

An optional external power receptacle may be installed in the left wing aft nacelle fairing. The receptacle accepts a standard AN-type external power source plug. The following precautions must be observed when starting an airplane using an external power source:

1. Avionics Master Switch - OFF.
2. Battery Switch - ON (The battery will tend to absorb transients that are present in some external power sources).
3. Alternator Switches - OFF.
4. Airplane Voltammeter - READ battery voltage.

NOTE

Set External Power Source Output Voltage to 28 volts.

5. External Power Source - TURN OFF before connecting to airplane.
6. External Power Source - ATTACH and TURN ON.
7. Airplane Voltammeter - READ VOLTAGE. (If external power source is properly connected, the reading will be greater than when reading battery voltage only).

LIGHTING SYSTEM

EXTERNAL LIGHTING

The airplane is equipped with three navigation lights, retractable landing lights (right light is optional), an optional taxi light, two anti-collision lights, optional strobe lights, an optional wing deice light and an optional cabin step light and a wing walkway light.

Navigation Lights

The navigation lights are located in the fuselage tail cone and in each main fuel tank forward fairing. These lights are energized with the navigation lights switch breaker on the switch and circuit breaker panel, see Figure 7-16. Proper operation can be checked by observing illumination in the small witness holes in the forward tips of the main fuel tanks and reflections on the ground below the tail light.

Landing Lights

The retractable landing lights (right light is optional) are located in the aft main fuel tank fairings. These lights are extended, retracted and illuminated by the landing light switch breaker on the switch and circuit breaker panel, see Figure 7-16. With the switch positioned to ON, the landing lights will extend and illuminate. In the OFF position, the lights will remain extended but will not illuminate. In the RETR position, the lights will retract flush with the respective main tank.

Taxi Lights

The optional taxi light, attached to the nose gear, provides adequate illumination for night taxiing. The taxi light is controlled by the taxi light switch breaker on the switch and circuit breaker panel, see Figure 7-16.

Anti-Collision Lights

Anti-collision lights are provided on the lower fuselage and forward rudder tip. These lights are actuated by the anti-collision light switch breaker on the switch and circuit breaker panel, see Figure 7-16. Do not operate in conditions of fog, clouds or haze as the reflection of the rotating light beam can cause disorientation or vertigo.

Strobe Lights

The optional wing strobe lights, with individual power supplies, are located adjacent to each navigation light. These lights are actuated by the strobe light switch breaker on the switch and circuit breaker panel, see Figure 7-16. The tail strobe light tube is mounted within the tail position light housing while its power supply is remotely located in the airplane tailcone. Do not operate in conditions of fog, clouds or haze as the reflection of the light beam can cause disorientation or vertigo.

Wing Deice Lights

The optional wing deice lights are installed in the outboard side of each engine nacelle and illuminate the outboard wing leading edge deice boots. The lights allow the pilot to check for ice accumulation on the wing leading edges. The lights are actuated by the deice light switch breaker on the switch and circuit breaker panel, see Figure 7-16.

Cabin Step And Wing Walkway Lights

The optional cabin step light and wing walkway light provide adequate illumination for night boarding. These lights are controlled by a switch on the instrument panel, see Figure 7-1, or by a push-button switch on the outside of the airplane adjacent to the baggage door.

COCKPIT LIGHTING CONTROLS

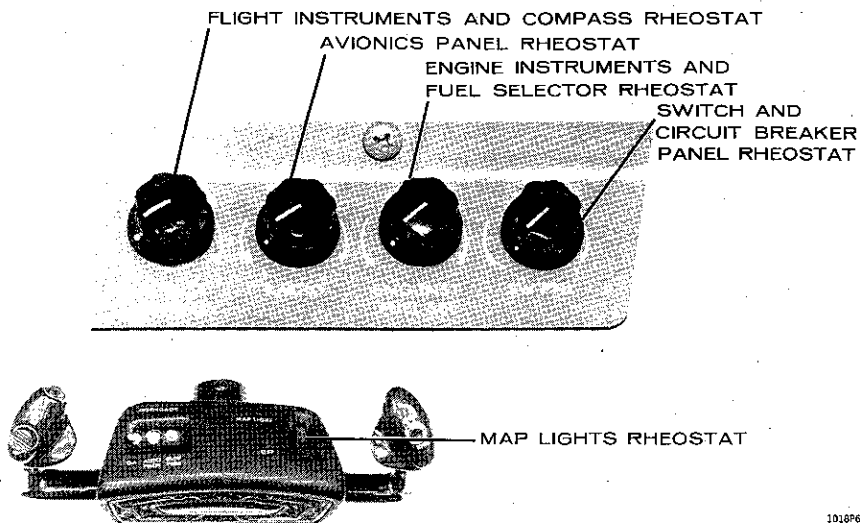

Figure 7-17

1014P6005
1014P6018

All exterior lighting should be checked for proper operation before night flying. Cockpit recognition of operational exterior lighting can be determined by looking for ground illumination or reflections on the ground and main fuel tanks by the various lights.

INTERNAL LIGHTING

The airplane is equipped with lighting for baggage areas, cockpit controls and indicators, cockpit illumination and cabin illumination.

Optional baggage area lights are provided for both wing lockers and the nose baggage areas. The lights are actuated when the applicable baggage door is opened and extinguish when the door is closed.

Cockpit lighting is provided by the instrument panel floodlight, instrument postlights, control wheel map light for the pilot and electroluminescent lighting for various placards. All cockpit lights, see Figure 7-17, except for the instrument panel floodlight and the map light, are variable intensity and are controlled by rheostats on the switch and circuit breaker panel. The instrument panel floodlight is controlled by a rheostat on the overhead console, see Figure 7-2. The map light is controlled by a rheostat on the control wheel, see Figure 7-17.

Individual reading lights and controls, see Figure 7-18, are provided in the cabin for each passenger seat.

CABIN LIGHTING AND CONTROLS

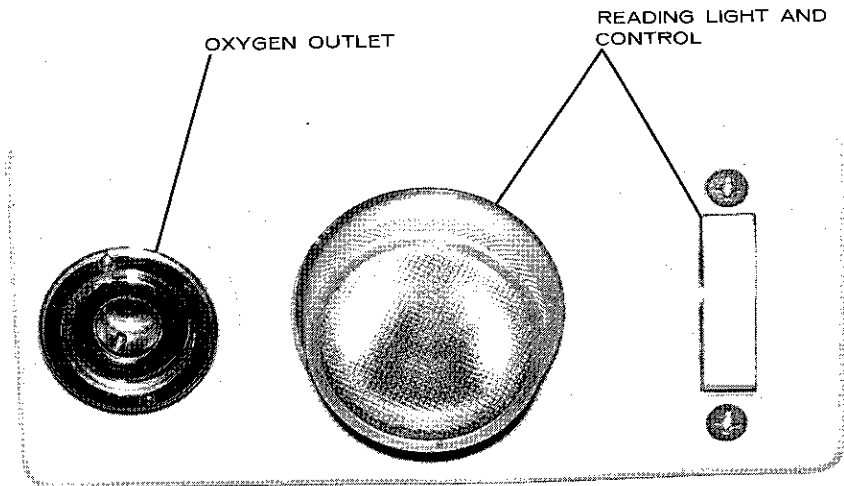

OVERHEAD PASSENGER CONTROL PANEL (TYPICAL)

Figure 7-18

PITOT PRESSURE SYSTEM

The standard pitot pressure system, see Figure 7-19, consists of an electrically heated pitot tube mounted on the left side of the fuselage nose cap, suitable plumbing and an airspeed indicator.

When the pitot heat switch is placed in the ON position, the heating elements in the pitot tube, stall warning vane and optional wing locker fuel vents are electrically heated to maintain proper operation of the pitot system, stall warning system and optional wing locker fuel system during icing conditions. Do not operate for prolonged periods while on the ground to prevent overheating of the heating elements.

When the optional copilot's instruments are installed, a second pitot system is used. This second pitot head is located on the right side of the fuselage nose cap and is connected to the copilot's airspeed indicator. This dual system allows a completely independent second presentation of airspeed pitot pressure. Pitot heat for the additional head is controlled by the pitot heat switch.

STATIC PRESSURE SYSTEM

Static pressure for the pilot's airspeed, altimeter and rate-of-climb indicators, see Figure 7-19, is obtained by a normal external static source or an alternate internal static source should the external source fail.

An alternate static pressure source and static system drain valve, installed in the static system below the parking brake handle, supplies an alternate static source to the pilot's instruments should the external static source malfunction. This valve also permits draining condensate from the static lines. When open, this valve vents to the static pressure in the cabin. Since this cabin pressure is relatively low, the airspeed indicator and the altimeter will show slightly higher readings than normal. Therefore, the alternate static source should be used primarily as a drain valve to restore the original system. Refer to Section 5 for airspeed and altimeter corrections when the static source is OPEN.

When the optional copilot's instruments are installed, a second set of static ports are installed below the standard static ports. The added static ports are manifolded together and are used as a reference for the copilot's instruments only. This dual system allows a completely independent second static pressure source. The drain valve for the copilot's instruments is located forward of the alternate static source and drain valve for the pilot's instruments. Use of this drain valve for an alternate static source is not approved. Optional static port heaters are controlled by the pitot heat switch.

VACUUM SYSTEM

A vacuum system, see Figure 7-20, is installed to provide a source of vacuum for the vacuum instruments. The system consists of an engine-driven vacuum pump on each engine, pressure relief valve for each pump, a common vacuum manifold, vacuum air filter, suction gage and gyro instruments.

PITOT STATIC SYSTEM

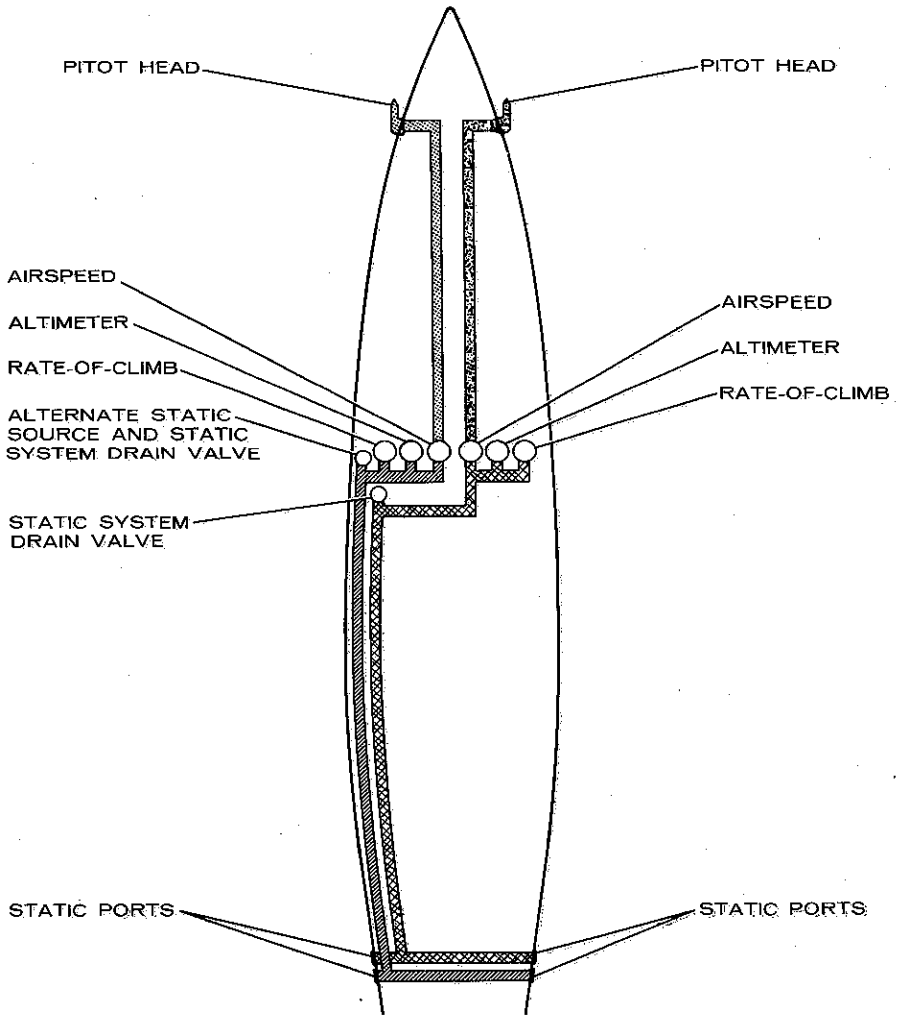

CODE





-  PILOT'S PITOT SYSTEM
-  PILOT'S STATIC SYSTEM
-  COPILOT'S PITOT SYSTEM (OPTIONAL)
-  COPILOT'S STATIC SYSTEM (OPTIONAL)

Figure 7-19

Each vacuum pump pulls a vacuum on the common manifold, exhausting the air overboard. The maximum amount of vacuum pulled on the manifold by each vacuum pump is controlled to a preset level by each pressure relief valve. Should either of the pumps fail, a check valve is provided in each end of the manifold to isolate the inoperative vacuum pump from the system.

The exhaust air side of each attitude gyro is connected to the vacuum manifold thus providing a smooth steady vacuum for the gyros. The vacuum pressure being applied to the gyros is constantly presented on the suction gage. This gage also provides failure indicators for the left and right vacuum pumps. These indicators are small red buttons located in the lower portion of the suction gage which are spring-loaded to the extended (failed) position. When normal vacuum is applied in the manifold, the failure buttons are pulled flush with the gage face. Should insufficient pressure occur on either side, the respective red button will extend. No corrective action is required by the pilot, as the system will automatically isolate the failed vacuum source, allowing normal operation on the remaining operative vacuum pump.

The inlet air side of the attitude gyros are connected to a common vacuum air filter which cleans the ambient cabin air before allowing it to enter the gyros.

FLIGHT INSTRUMENTS

The basic flight instruments, see Figure 7-1, consist of airspeed, altimeter and rate-of-climb indicators, electric turn-and-bank and vacuum horizon and directional gyros.

Operation of the airspeed, altimeter and rate-of-climb indicators can be determined by cross-checking the copilot's instruments, if installed. Also, when a climb or descent is initiated, these instruments should indicate the appropriate change. If no change is indicated, it is reasonable to assume static source blockage has occurred and the alternate static source should be selected. If the possibility of static source icing is present, actuation of the pitot heat switch might deceive the static sources, allowing a return to the normal static source, if the optional heated static sources are installed. If only the airspeed indicator appears to be affected when the climb or descent is initiated, it is reasonable to assume a pitot system blockage has occurred. If the possibility of pitot source icing is present, actuation of the pitot heat switch will clear the ice blockage. Reference the optional copilot's instruments and optional angle-of-attack indicator for airspeed information until a reliable airspeed indication can be obtained. If neither optional system is installed, fly attitude and power references.

Operation of the turn-and-bank needle can be checked by initiating a standard rate turn and cross-checking the turn rate with the directional gyro. An indicated standard rate turn should show a turning rate of 3 degrees per second on the directional gyro. Pressing the turn and bank indicator PRESS-TO-TEST light below the directional gyro will cause the light to illuminate if power is being applied to the turn-and-bank indicator. After shutdown of the airplane on the ground, abnormal noise coming from the turn-and-bank can indicate a near failure condition. The ball part of the turn-and-bank is virtually failure proof. Inaccuracy can result only if the indicator is not level in the instrument panel. With the airplane on level ground, the ball should be centered in the race.

**VACUUM SYSTEM
STANDARD SYSTEM**

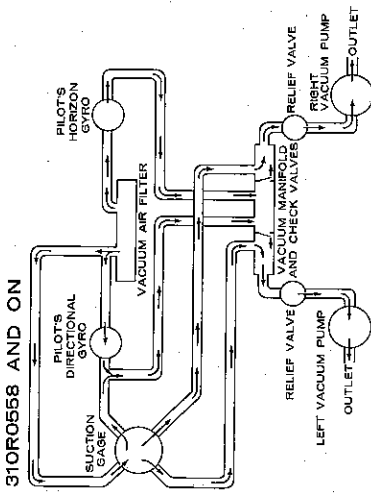
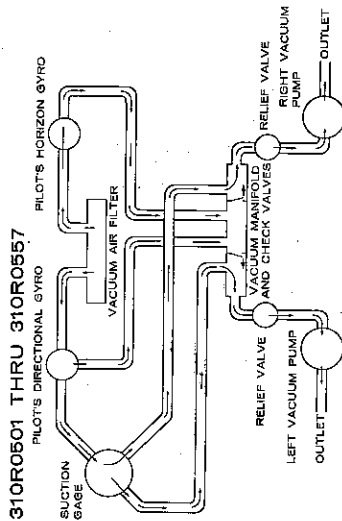

OPTIONAL SYSTEM

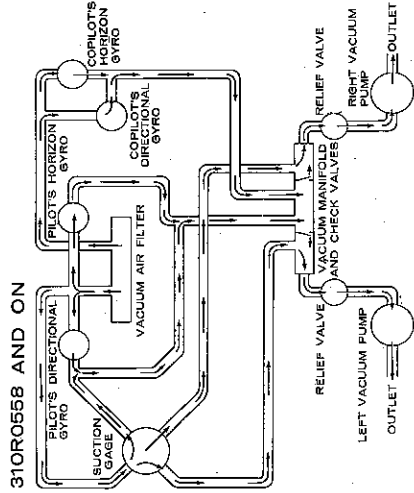
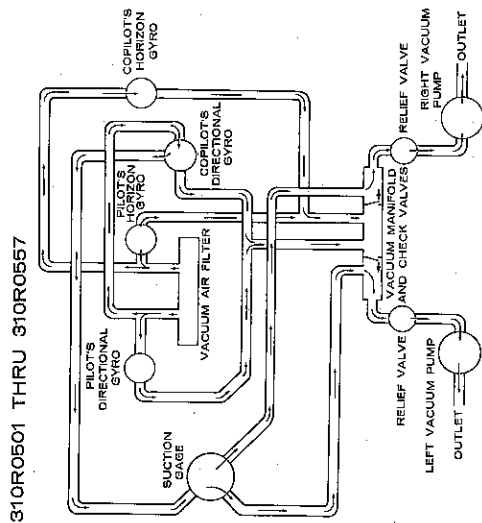

Figure 7-20

Operation of the directional and horizon gyros can be checked during taxiing by watching for an abnormally slow erection rate and erratic operation. After shutdown of the airplane on the ground, abnormal noise coming from either gyro can indicate a near failure condition. Checking the suction gage for proper vacuum and no failure buttons exposed will assure proper gyro vacuum is available.

In flight, the directional gyro can be checked by flying a standard rate turn and observing the directional gyro for a turning rate of 3 degrees per second. Also the precession rate in straight and level flight should not exceed 5 degrees in 10 minutes. The horizon gyro operation can be checked by establishing a level flight attitude; the gyro should indicate wings level within 1 degree. Initiate a 20-degree bank for a 180-degree turn, then smoothly return to level flight; gyro should indicate wings level within 3 degrees. Establish level flight at 150 KIAS; gyro should indicate level airplane within 1 degree. Smoothly pitch airplane nose down 10 degrees, then return to level flight; gyro should indicate level flight within one degree.

STALL WARNING SYSTEM

A stall warning system is required equipment which consists of a stall warning transmitter vane located in the left outboard wing leading edge, a cockpit warning horn and the necessary wiring to complete the system.

The stall warning horn will sound 5 to 10 KIAS above the stall in all flight configurations. Proper operation of the warning system can be checked during preflight inspection by moving the stall warning vane; the horn should sound. Condition of the stall warning vane heater should also be checked during preflight by actuating the pitot heat switch and feeling the vane for heat.

AVIONICS

AVIONICS MASTER SWITCHES

Two optional avionics master switches are provided with factory installed avionics. The master switch breaker labeled AVN MASTER is located on the top section of the switch and circuit breaker panel, see Figure 7-16. This switch supplies power from the battery bus through a circuit breaker located aft of the battery box to the individual avionics circuit breakers and is used for all normal operations. An emergency avionics master switch breaker labeled EMG AVN PWR is located in the lower section of the switch and circuit breaker panel and is protected by a red switch guard cover, see Figure 7-16. This switch supplies power from the alternator bus to the individual avionics circuit breakers. The emergency avionics master switch is recommended for use only when the avionics master switch, associated wiring or battery circuits become inoperative.

ENGINES

The airplane is equipped with two Continental six-cylinder, fuel-injected engines. Each engine is rated at 285 horsepower at 2700 RPM. Each engine is provided with an oil pump, fuel pump, vacuum pump, propeller governor, tachometer generator, starter and alternator.

ENGINE CONTROLS

The control pedestal contains all engine controls. The three primary engine controls are in groups of two at the top of the pedestal; starting from left to right they are: (1) throttle, (2) propeller and (3) mixture.

Throttle Control

The throttle control lever, see Figure 7-1, is used to increase or decrease the engine power by moving the butterfly valve in the fuel-air control unit.

Propeller Control

The propeller control lever, see Figure 7-1, is used to change the propeller pitch to maintain or set a desired engine RPM.

Mixture Control

The mixture control lever, see Figure 7-1, is used to control the amount of fuel to be metered by the fuel-air control unit.

Quadrant Friction Lock

A quadrant friction lock, see Figure 7-1, is provided to prevent the three primary engine controls (six total levers) from creeping once they have been set. The locking knob (approximately one and one-half inches in diameter) is located on the right side of the pedestal.

Cowl Flap Control

Two cowl flap controls, see Figure 7-1, are located just below the rudder trim tab wheel; one control for each engine. These controls are used to set the cowl flaps in any position from full open to full closed. A locking feature is provided for each control to prevent inadvertent cowl flap position change. Rotating the control clockwise engages the locking mechanism.

Alternate Air Control

An alternate air control is provided for each engine, see Figure 7-1. These mechanically actuated, controls are located on the right side of the control pedestal. Normally the controls are pushed in, providing cold filtered ram air to the engines. When the controls are pulled out, warm unfiltered air from inside the cowling is provided to the engines. A locking feature is provided for each control to prevent inadvertent alternate air control position change. Rotating the control clockwise engages the locking mechanism.

ENGINE OIL SYSTEM

The Continental engines installed in the airplane have a wet sump type, pressure lubricating system. Oil temperature is controlled by a thermally operated valve which either routes oil through the externally mounted cooler or bypasses the oil around the cooler. Oil is routed through internal passages to all moving parts of the engine which require lubrication.

In addition to providing lubrication and cooling for the engine, the oil is used for control of the propeller.

Oil pressures from both engines are routed into the fuselage, to the left and right engine gages, see Figure 7-1, where direct oil pressure readings are mechanically displayed. The oil temperatures of both engines are measured on the output side of the oil coolers. The measurements are electrically transmitted to the left and right engine gages where the oil temperatures are displayed.

IGNITION SYSTEM

Each engine is equipped with a dual ignition system. The ignition systems are entirely independent from each other such that a failure of any part of one system will have no effect on the other system. Each system consists of a magneto located on the rear engine accessory case, ignition harness to distribute the electrical energy and a spark plug in each engine cylinder. The left magneto fires the lower right and upper left spark plugs while the right magneto fires the upper right and lower left spark plugs. When the primary circuit of each magneto is electrically grounded by placing the magneto switch in the OFF position, the magneto will not produce a spark. With the magneto switch positioned to ON, the primary magneto circuit is ungrounded, allowing a high voltage spark to be produced to fire the spark plugs. During engine starting, a high voltage vibrator supplements the magneto spark to assure a fast start.

FUEL SYSTEM

Fuel is supplied to the engine using a low-pressure injection system. The fuel is injected into the cylinder head adjacent to the intake valve on all cylinders. This continuous flow type injection system controls fuel flow to match engine airflow. A manual mixture control and a flow gage, see Figure 7-1, indicating fuel flow are provided for precise leaning at any combination of altitude and power setting. There are no moving parts in this system except for the engine-driven fuel injection pump.

INTERNAL COWL FLAP SYSTEM

An internal cowl flap system is provided for each engine to allow manual control of the engine cooling airflow. Each system consists of a spring-loaded open cowl flap located below the louvers of the upper engine cowl inside the engine compartment. Actuation of the cowl flaps is achieved by use of a push-pull cable assembly. The cowl flap controls, located on the lower control pedestal, allow any intermediate position to be selected. A locking feature is provided for each control to prevent inadvertent cowl flap position change. Unlike external cowl flaps that are designed to reduce engine temperatures, the internal cowl flaps are designed to increase engine temperatures during low power climb, cruise, descent and operations in below standard ambient conditions. Cowl flap position has no effect on cruise or climb performance.

STARTING SYSTEM

The starting system consists of a 24-volt lead acid battery, a direct-drive starter mounted on each engine, a starter button for each engine and necessary wiring and components to complete the system.

The starter is engaged when the starter button, located below the pilot's control wheel, is pushed, see Figure 7-1. Pushing the button closes the starting relay, allowing the starter to be energized. While the starter is energized, a starting vibrator provides a high-voltage current through the left magneto at a retarded position to assist the normal magneto ignition during the start.

ENGINE INSTRUMENTS

Engine instrumentation for each engine, see Figure 7-1, consists of mechanical oil pressure, electrical oil temperature and electrical cylinder head temperature presented on the combination engine gage, a mechanical manifold pressure gage, electric tachometer and mechanical fuel flow gage. The gages are placarded as to their operational parameters.

ENGINE MOUNTS

The engine is mounted to the nacelle structure by four engine mounts. Each mount incorporates two rubber pads capable of sustaining operational loads and providing absorption for engine vibrations.

ENGINE BREAK-IN PROCEDURE

The engine underwent a run-in at the factory and is ready for the full range of use. It is, however, recommended that cruising be accomplished at 65% to 75% power until a total of 50 hours has accumulated or oil consumption has stabilized.

CAUTION

The purpose of operating at 65% to 75% power with Best Power or Recommended Lean mixture is to insure proper seating of the rings and is applicable to new engines, and engines in service following cylinder replacement or top overhaul of one or more cylinders.

The airplane is delivered from the factory with corrosion preventive oil in the engine. This oil allows fast ring seating and should not be used any longer than 25 hours. If during the first 25 hours oil must be added, use only aviation grade straight mineral oil conforming to Specification MIL-L-6082. Refer to Section 8 for additional oil servicing information.

HEATING, VENTILATING AND DEFROSTING SYSTEM

The cabin air system provides for cabin heating, ventilating and defrosting. The system consists of an air inlet in the nose, a cabin fan, a gasoline combustion-type heater and controllable heat outlets in the cabin. Two heat outlets are located at the base of the windshield for defrosting purposes. One outlet duct is located on the forward cabin bulkhead and one is located on each side of the forward cabin. Two additional outlets are located in the aft passenger compartment on the aft face of the main spar, see Figure 7-21.

HEATING AND DEFROSTING

Fresh air is picked up from the air inlet in the nose of the airplane, heated by the heater, and directed to the cockpit and cabin. The heating and ventilating air is not recirculated, but exhausts overboard through the aft cabin exhaust air outlet.

The heating system can be used for ventilation by placing the cabin heat switch, see Figure 7-1, in the CABIN FAN position. The fan provides unheated fresh air to the cabin through the cabin heat outlets. In flight, the fan becomes inoperative and the heating system can be used for ventilation by placing the cabin heat switch to the OFF position, turning the cabin air knobs to OPEN, and opening the heat outlets as desired.

CABIN HEAT SWITCH

The cabin heater is controlled by a three-position cabin heat switch, see Figure 7-1. Switch positions are HEAT, OFF and FAN. Placing the switch in the HEAT position starts and maintains heater operation. Placing the switch in the FAN position provides ventilation for the cabin while the airplane is on the ground.

CABIN AIR TEMPERATURE CONTROL KNOB

The cabin air temperature is controlled by the temperature control knob, see Figure 7-1. Counterclockwise rotation of this knob increases the desired temperature.

This knob adjusts a thermostat, which in turn controls heated air temperature in a duct located just aft of the heater. When the temperature of the heated air exceeds the setting of the thermostat, the thermostat automatically opens and shuts off the heater. When the heated air cools to the thermostat setting, the heater starts again. Thus the heater cycles on and off to maintain an even air temperature.

FORWARD CABIN AIR KNOB

The forward cabin air knob directs warm air to the outlet located on the forward cabin bulkhead. This direct outlet allows fast warm-up when the airplane is on the ground. Airflow through the direct outlet is completely shutoff when the knob is turned to CLOSED. The knob may be set at any intermediate position to regulate the quantity of air to the pilot's compartment.

CABIN AIR KNOB

The cabin air knob controls airflow to all passenger compartment heat registers. When the knob is turned to OPEN, the air flows to heat registers in the passengers' compartment. Airflow to the heat registers is completely shutoff by turning the knob to CLOSED. The knob may be set in any intermediate position to regulate the quantity of air to the cabin.

CABIN HEAT REGISTERS

Two cabin heat registers are located on the aft side of the main spar beneath the pilot's and copilot's seats and one on each side in the forward cabin. Each register is provided with a lever operated rotary-type valve which controls the amount of air coming from the heat registers. Each register is marked for open or closed and may be placed in any intermediate position to regulate the amount of air coming from the registers.

DEFROST KNOB

Windshield defrosting and defogging is controlled by the DEFROST knob. When the knob is turned to OPEN, air flows from the defroster outlets at the base of the windshield. When the knob is turned to CLOSED, airflow to the defroster outlets is shut off. The knob may be set in any intermediate position to regulate the defroster airflow.

HEATER OVERHEAT WARNING LIGHT

An amber overheat warning light provided on the instrument panel is labeled OVERHEAT, see Figure 7-1. When illuminated, the light indicates that the heater overheat switch has been actuated and that the temperature of the air in the heater has exceeded 163°C (325°F). Once the heater overheat switch has been actuated, the heater turns off and cannot be restarted until the overheat switch, located in the right forward nose compartment, has been reset. Prior to having the overheat switch reset, the heater should be thoroughly checked to determine the reason for the malfunction.

HEATER OPERATION FOR HEATING AND DEFROSTING

- (1) Battery Switch - ON.
- (2) Cabin Air Knobs - OPEN.
- (3) Defrost Knob - Adjust as desired (if defrosting is desired).
- (4) Temperature Control Knob - OPEN.
- (5) Cabin Heat Switch - HEAT.
- (6) Heat Registers - As desired.

NOTE

- If warm air is not felt coming out of the registers within one minute, turn cabin heat switch OFF; check circuit breaker and try another start. If heater still does not start, no further starting attempt should be made.
- During heater operation, defrost and/or cabin air knobs must be open.

HEATING, VENTILATING AND DEFROST SYSTEM

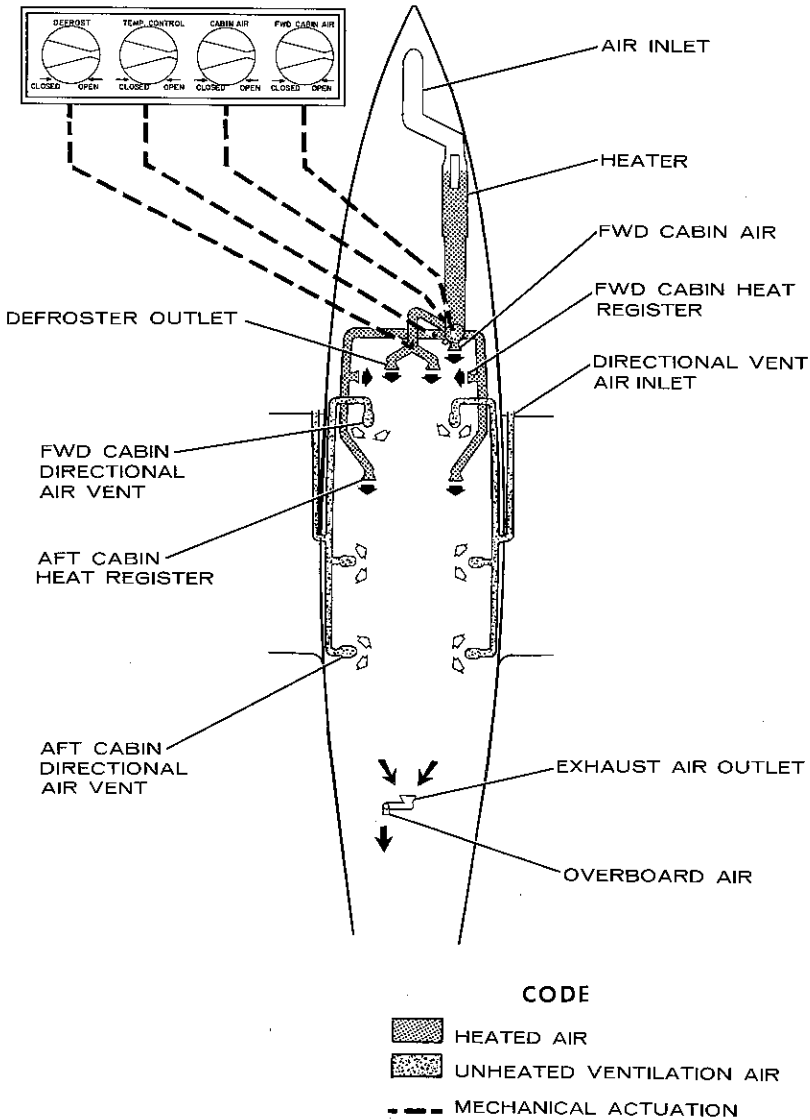

Figure 7-21

HEATER USED FOR VENTILATION

- (1) Battery Switch - ON.
- (2) Cabin Air Knobs - OPEN as desired.
- (3) Cabin Heat Switch - FAN.
- (4) Heat Registers - As desired.

VENTILATING SYSTEM

In addition to the ventilation provided by the cabin heating system, a separate ventilation system obtains ram air from the wing root leading edge air inlets and ducts it to the directional vents. The ventilating system functions only in flight, since it depends entirely on ram air pressure. For ground ventilation, the ventilating fan of the heating system must be used.

BAGGAGE COMPARTMENTS

Five baggage locations, see Figure 1-3, are available with the standard seating arrangement: one in the fuselage nose section, two in the aft cabin area and one in the aft portion of each engine nacelle.

These baggage areas are intended primarily for low-density items such as luggage and briefcases. The floors of the wing locker baggage areas are primary structure. Therefore, care should be exercised during loading and unloading to prevent damage. When loading high-density objects, insure that adequate protection is available to prevent damage to any of the airplane's primary structure. Without optional equipment installed, 120 pounds can be carried in each wing locker, 350 pounds in the nose baggage compartment, 200 pounds in the aft cabin (Station 96) and 160 pounds in the aft cabin (Station 124 - Standard or Station 126 - Optional). With optional equipment installed, refer to Section 2 or the loading placards in your airplane's baggage compartments.

WARNING

- The transportation of hazardous materials is discouraged. However, if transport of this material is necessary, it shall be done in accordance with FAR 103 and any other applicable regulations.
- Under no circumstances, allow the loading of people or animals in the nose baggage area or wing lockers. These areas do not qualify for carriage of animate objects.

AIRPLANE TIE-DOWN PROVISIONS AND JACK POINTS

A wing tie-down fitting is provided on the lower surface of each wing outboard of each engine nacelle. The fittings are located aft of the leading edge and retract into the wing when not in use. The empennage is secured at the tail tie-down fitting located on the fuselage bottom, below the elevator hinge line. In addition the nose gear can be secured with ropes attached to the nose gear assembly above the scissors linkage.

Three jack points are provided; they are located aft of each main landing gear door hinge for the main gear and aft and outboard of the left nose gear door hinge for the nose gear.

SEATS, SEAT BELTS AND SHOULDER HARNESSSES

PILOT AND COPILOT PROVISIONS

The pilot and copilot seats are secured to seat pan assemblies which are attached to the forward main spar carry-thru structure. The seats are adjustable fore and aft on seat rails by lifting the handle located on the forward face of the seat.

Seat belts are provided for both seats and are attached to the seat structure. The shoulder harnesses attach aft and outboard of the pilot's and copilot's seats to overhead structure. The opposite end of each harness attaches permanently to the outboard pilot's or copilot's seat belt. An adjustment is provided between the attach points. With the optional shoulder harnesses, inertia reels are bolted to overhead structure aft and outboard of the pilot's and copilot's seats. The opposite end of the harnesses attach to the seat belts with a detachable fastener. The inertia reels allow normal fore and aft movement of the occupants until a violent movement occurs, at which time the reel will lock, restricting forward movement of the seat occupant.

PASSENGER PROVISIONS

The standard 4-place configuration has a double seat that incorporates individual reclining adjustments. The seat is secured in a stationary position to the floor structure. Each seat position is equipped with a seat belt which is attached to the seat structure. Shoulder harnesses are not available for the passenger seats.

The optional 6-place configuration has two individual center seats and two individual aft seats. The center seats are mounted on seat tracks and may be adjusted forward and aft. The aft seats may be adjusted to the recline position. The aft seats are secured in a stationary position to the floor structure with quick-disconnect fasteners. Each seat position is equipped with a seat belt. The seat belts on the center seats are attached to the seat structure. The seat belts on the aft seats are attached to the floor structure.

NOTE

Insure that the individual center seat's stop pins are engaged with the holes in the seat rails before takeoff and landing.

DOORS, WINDOWS AND EXITS

CABIN DOOR

The cabin door is a one-piece, single-hinged door located on the right side of the fuselage above the wing. A hold-open assembly on the bottom of the door frame will keep the door in the open position. The door can be opened by either the outside or inside handle.

WINDOWS

There are five fixed windows in the airplane, consisting of a rear omni window, two side picture windows, an emergency exit window on the pilot's side and a cabin door window. The emergency exit window also contains an integrally mounted foul weather window. The foul weather window can be opened during all ground operations and inflight. Airspeed is not restricted with the foul weather window open.

EMERGENCY EXIT WINDOW

The pilot's side window may be removed for emergency exit by removing the plastic cover over the red emergency pulling, pulling the ring to release the window retainers and pushing out at the bottom of the window with sustained force to remove the window. The emergency window is held in at the top by retaining pins. When the window is pushed open far enough, the pins will slip out of their retainers and the window will fall free.

CONTROL LOCKS

A control column lock is provided to restrict the control column from moving. This restriction holds the elevators and ailerons in a neutral position, thus preventing damage to the control surfaces in gusty wind conditions. The rudder is secured with the optional rudder gust lock or by placing an external control surface lock over the vertical stabilizer and rudder. If neither rudder lock is available, caster the nosewheel to the full left or right position. This action will deflect the rudder against its stop, thus restricting rudder movement.

WARNING

Insure all control locks are removed before starting the engines.

PROPELLERS

The airplane is equipped with all-metal, three-bladed, constant-speed, full-feathering, single-acting, governor-regulated propellers. Each propeller utilizes oil pressure which opposes the force of springs and counterweights to obtain correct pitch for engine load. Oil pressure from the propeller governor drives the blades toward low pitch (increasing RPM) while the springs and counterweights drive blades toward high pitch (decreasing RPM). The source of oil pressure for propeller operation is furnished by the engine oil system, boosted in pressure by the governor gear pump, and supplied to the propeller hub through the engine crankshaft flange.

To feather the propeller blades, the propeller control levers on the control pedestal must be placed in the feather position. Unfeathering the propeller is accomplished by positioning the propeller control lever to the increase RPM position. The optional unfeathering system uses accumulator air and oil to force the propeller out of feather and into the low pitch condition.

CAUTION

Do not feather the propeller below 700 RPM as this may damage the hub mechanism.

PROPELLER SYNCHROPHASER

The optional propeller synchrophaser system, see Figure 7-22, is designed to match propeller RPM and propeller phase angle of the two engines. The propeller RPM and phase angle of the slaved (left) engine will follow changes in RPM and phase angle of the master (right) engine over a limited range. This limited range feature prevents the left engine from losing more than 50 propeller RPM should the right engine be feathered with the synchrophaser system on. In addition, the optimum phase relationship between the left and right propeller blades can be selected by the pilot for minimum noise and vibration in the cabin.

With the function switch in the OFF position, the system is deenergized and the automatic phaser RPM control is positioned to its mid-range to insure normal operation when next turned on. With the function switch in the SYNC position, the synchrophaser operates as a synchronizer, maintaining the same propeller RPM on both engines. With the function switch in the PHASE position, the propeller RPM of the left and right engines will be synchronized and the phase angle of the left engine can be phased with the phase angle of the right engine by adjusting the phasing rheostat.

The synchrophaser light will be illuminated when the SYNC or PHASE functions are selected. The light will flash when the difference between the left and right propeller RPM exceeds 50 RPM. As the left propeller RPM is manually synchronized to the right propeller RPM, the light will flash at a slower rate until the RPM difference is less than 50, at which time the light will illuminate continuously.

PROPELLER SYNCHROPHASER

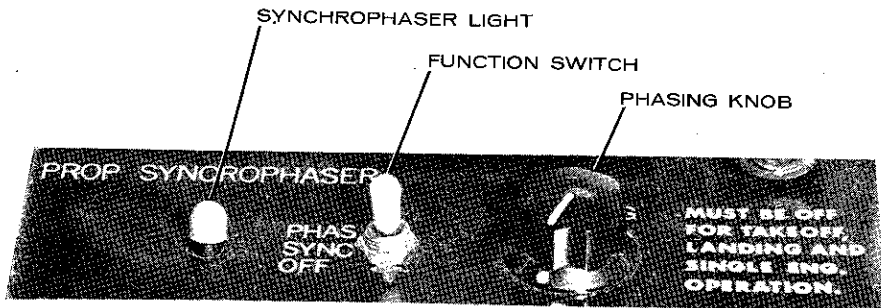

Figure 7-22

Make certain that both engines are functioning properly with the synchrophaser turned off. The PHASE position should only be used in level cruising flight in smooth air. Any major deviations from level flight will cause the slipstream pattern over the left engine propeller to change, which in turn will cause a sound level change. Since the left propeller is slaved to the right propeller, and the slaving range is limited, the synchrophaser should not be operated at either extreme of the RPM governing range.

For best operation, it is important to guard against propeller control creeping by setting the quadrant friction lock tightly, see Figure 7-1. On extended flights, it may be necessary to periodically switch to the OFF position, reset the propeller control levers and reengage the synchrophaser.

NOTE

- Manually synchronize the propellers prior to selecting the SYNC or PHASE positions.
- The propeller synchrophaser must be positioned to OFF during takeoff, landing and single-engine operation.

SECTION 8

AIRPLANE HANDLING, SERVICE AND MAINTENANCE

TABLE OF CONTENTS

	Page		Page
INTRODUCTION	8-1	FLYABLE STORAGE	8-7
Publications	8-2	SERVICING	8-9
OWNER FOLLOW-UP SYSTEM	8-2	Fuel	8-9
INSPECTION REQUIREMENTS	8-2	Oil	8-11
Cessna Progressive Care		Oxygen	8-12
Program	8-3	Alcohol Windshield	
Cessna Customer Care		Deice Reservoir	8-13
Program	8-3	Tires	8-13
Servicing Requirements	8-4	AIRPLANE CLEANING AND CARE	8-13
Airplane File	8-4	Painted Surfaces	8-13
Preventive Maintenance	8-5	Propeller	8-13
ALTERATIONS OR REPAIRS		Landing Gear	8-14
TO THE AIRPLANE	8-5	Deice Boots	8-14
GROUND HANDLING	8-5	Engines	8-15
Towing	8-5	Interior Care	8-15
Parking	8-6	Windows and Wind-	
Tie-Down	8-6	shield	8-16
JACKING AND LEVELING	8-7	Oxygen Masks	8-16

INTRODUCTION

Section 8 of the Pilot's Operating Handbook provides information on cleaning, inspection, servicing and maintenance of the airplane.

If your airplane is to retain the new plane performance and dependability, certain inspection and maintenance requirements must be followed. It is wise to follow a planned schedule of lubrication and preventive maintenance based on climatic and flying conditions encountered in your locality.

Keep in touch with your Cessna Dealer, and take advantage of his knowledge and experience. He knows your airplane and how to maintain it. He will remind you when lubrications and oil changes are necessary, and about other seasonal and periodic services.

All correspondence concerning your airplane should include the airplane model and serial number. This information may be obtained from the FAR-45 required identification plate located on the main cabin door forward post. Refer to the Airplane Service Manual for an illustration of the identification plate.

PUBLICATIONS

Various publications and flight operation aids are furnished in the airplane when delivered from the factory. These items are listed as follows:

CUSTOMER CARE PROGRAM BOOK
PILOT'S OPERATING HANDBOOK
PILOT'S CHECKLIST
AVIONICS OPERATION GUIDE
POWER COMPUTER
SALES AND SERVICE DEALER DIRECTORY
DO'S AND DON'TS ENGINE BOOKLET

The following additional publications, plus many other supplies that are applicable to your airplane, are available from your Cessna Dealer.

SERVICE MANUALS AND PARTS CATALOGS FOR YOUR
AIRPLANE
ENGINE AND ACCESSORIES
AVIONICS

Your Cessna Dealer has a current catalog of all Customer Services Supplies that are available, many of which he keeps on hand. Supplies which are not in stock, he will be happy to order for you.

OWNER FOLLOW-UP SYSTEM

Your Cessna Dealer has an Owner Follow-Up System to notify you when he receives information that applies to your Cessna. In addition, if you wish, you may choose to receive similar notification, in the form of Service Letters, directly from the Cessna Customer Services Department. A subscription form is supplied in your Customer Care Program book for your use should you choose to request this service. Your Cessna Dealer will be glad to supply you with details concerning these follow-up programs, and stands ready, through his Service Department, to supply you with fast, efficient, low cost service.

INSPECTION REQUIREMENTS

As required by Federal Aviation Regulations, all civil airplanes of U.S. registry must undergo a complete inspection (annual) each twelve calendar months. In addition to the required annual inspection, airplanes operated commercially (for hire) must have a complete inspection every 100 hours of operation.

In lieu of the above requirements, an airplane may be inspected in accordance with a progressive inspection schedule, which allows the work load to be divided into smaller operations that can be accomplished in shorter time periods.

The Cessna Progressive Care Program has been developed to provide a modern progressive inspection schedule that satisfies the complete airplane inspection requirements of both the 100-hour and annual inspections as applicable to Cessna airplanes.

Additional inspections may be required by the FAA. These inspections are issued in the form of Airworthiness Directives and can apply to the airframe, engines and/or components of the airplane. It is the owner's responsibility to insure compliance with these directives. In some cases, the Airworthiness Directives require repetitive compliance; therefore, the owner should insure inadvertent noncompliance does not occur at future inspection intervals.

NOTE

Refer to FAR Parts 43 and 91 for properly certified agency or personnel to accomplish the inspections. Contact your local Cessna Dealer for additional information.

CESSNA PROGRESSIVE CARE PROGRAM

The Cessna Progressive Care Program has been designed to help you realize maximum utilization of your airplane at a minimum cost and downtime. Under this program, your airplane is inspected and maintained in four operations at 50-hour intervals during a 200-hour period. The operations are recycled each 200 hours and are recorded in a specially provided Aircraft Inspection Log as each operation is conducted.

The Cessna Aircraft Company recommends Progressive Care for airplanes that are being flown 200 hours or more per year, and the 100-hour inspection for all other airplanes. The procedures for the Progressive Care Program and the 100-hour inspection have been carefully worked out by the factory and are followed by the Cessna Dealer Organization. The complete familiarity of Cessna Dealers with Cessna equipment and factory-approved procedures provides the highest level of service possible at lower cost to Cessna owners.

CESSNA CUSTOMER CARE PROGRAM

Specific benefits and provisions of the Cessna Warranty plus other important benefits for you are contained in your Customer Care Program book supplied with your airplane. You will want to thoroughly review your Customer Care Program book and keep it in your airplane at all times.

Coupons attached to the Program book entitle you to an initial inspection and either a Progressive Care Operation No. 1 or the first 100-hour inspection within the first 6 months of ownership at no charge to you. If you take delivery from your Dealer, the initial inspection will have been performed before delivery of the airplane to you. If you pick up your airplane at the factory, plan to take it to your Dealer reasonably soon after you take delivery, so the initial inspection may be performed allowing the Dealer to make any minor adjustments which may be necessary.

You will also want to return to your Dealer either at 50 hours for your first Progressive Care Operation, or at 100 hours for your first 100-hour inspection depending on which program you choose to establish for your airplane. While these important inspections will be performed for you by any Cessna Dealer, in most cases you will prefer to have the Dealer from whom you purchased the airplane accomplish this work.

SERVICING REQUIREMENTS

For quick and ready reference, quantities, materials, and specifications for frequently used service items (such as fuel, oil, etc.) are shown in this section.

In addition to the Preflight Inspection covered in Section 4, complete servicing, inspection, and test requirements for your airplane are detailed in the Airplane Service Manual. The Service Manual outlines all items which require attention at 50, 100, and 200 hour intervals plus those items which require servicing, inspection, and/or testing at special intervals.

Since Cessna Dealers conduct all service, inspection, and test procedures in accordance with applicable Service Manuals, it is recommended that you contact your Dealer concerning these requirements and begin scheduling your airplane for service at the recommended intervals.

Cessna Progressive Care ensures that these requirements are accomplished at the required intervals to comply with the 100-hour or annual inspection as previously covered.

Depending on various flight operations, your local government aviation agency may require additional service, inspections, or tests. For these regulatory requirements, owners should check with local aviation officials where the airplane is being operated.

AIRPLANE FILE

There are miscellaneous data, information and licenses that are a part of the airplane file. The following is a checklist for that file. In addition, a periodic check should be made of the latest Federal Aviation Regulations to insure that all data requirements are met.

- A. To be displayed in the airplane at all times:
 - (1) Aircraft Airworthiness Certificate (FAA Form 8100-2).
 - (2) Aircraft Registration Certificate (AC Form 8050-3).
 - (3) Aircraft Radio Station License (Form FCC-556, if transmitter installed).
- B. To be carried in the airplane at all times:
 - (1) Weight and Balance, and associated papers (latest copy of the Repair and Alteration Form, Form 337, if applicable).
 - (2) Airplane Equipment List.
 - (3) Pilot's Operating Handbook
 - (4) Pilot's Checklist
- C. To be made available upon request:
 - (1) Airplane Log Book
 - (2) Engine Log Books

Most of the items listed are required by the United States Federal Aviation Regulations. Since the regulations of other nations may require other documents and data, owners of airplanes not registered in the United States should check with their own aviation officials to determine their individual requirements.

Cessna recommends that these items, plus the power computer, Customer Care Program book and Customer Care Card, be carried in the airplane at all times.

PREVENTIVE MAINTENANCE

Part 43 of the FAR's allows the holder of a pilot certificate, issued under Part 61, to perform preventive maintenance on any airplane owned or operated by him that is not used in air carrier service. Refer to FAR Part 43 for a list of preventive maintenance items the pilot is authorized to accomplish.

NOTE

- Prior to performance of preventive maintenance, review the applicable procedures in the Airplane Service Manual to insure the procedure is properly completed.
- All maintenance other than preventive maintenance must be accomplished by appropriately licensed personnel. Contact your Cessna Dealer for additional information.
- Pilots operating airplanes of other than United States registry should refer to the regulations of the country of certification for information on preventive maintenance that may be performed by pilots.

ALTERATIONS OR REPAIRS TO THE AIRPLANE

Alterations or repairs to the airplane must be accomplished by appropriately licensed personnel. If alterations are considered, the FAA should be consulted to insure that the airworthiness of the airplane is not violated.

GROUND HANDLING

TOWING

The airplane should be moved on the ground with the aid of the nose-wheel towing bar provided with the airplane. The tow bar is designed to attach to the nose gear strut fork.

CAUTION

Remove all rudder locks before ground handling. When using the tow bar, never exceed the nosewheel turning radius limits of 55° either side of the center. Structural damage may occur if the turn limits are exceeded. Do not push or pull on propellers or control surfaces when moving the airplane on the ground.

Should towing operations be required which cannot be accomplished with the nosewheel towing bar, refer to the Airplane Service Manual for proper towing procedures using the main landing gear.

PARKING

Parking is normally accomplished with the nosewheel aligned straight ahead. This minimizes stress on the nose gear during starting and simplifies the steering during subsequent departures from the parking area. If gusty wind conditions prevail and the optional rudder gust lock is not installed, restrict rudder travel with an external rudder gust lock or caster the nosewheel to the extreme right or left position. This forces the rudder against the rudder stop which minimizes buffeting of the rudder in gusty weather. When parking the airplane, head into the wind and set the parking brake.

CAUTION

Do not set parking brakes when the brakes are overheated or during cold weather when accumulated moisture may freeze the brakes.

When setting the parking brake is impractical, chock the main and nose wheels to prevent airplane movement.

With the mixture levers in IDLE CUT-OFF, the fuel flow is effectively blocked at the fuel metering unit. Thus, it is unnecessary to place the fuel selectors in the OFF position if the airplane is receiving normal usage. However, if a long period of inactivity is anticipated, the fuel selectors should be turned OFF to preclude any possible fuel seepage that might develop through the metering valve.

NOTE

Do not leave the fuel selectors in an intermediate position, as fuel from the main tanks will transfer into the auxiliary tanks.

TIE-DOWN

Proper tie-down procedure is the best precaution against damage to a parked airplane by gusty or strong winds. To tie-down the airplane securely, proceed as follows:

1. Head airplane into the wind if possible. Close engine cowl flaps after engines have cooled sufficiently.
2. Set parking brake and install control locks to restrict travel of all movable surfaces.

CAUTION

Do not set parking brake when the brakes are overheated or during cold weather when accumulated moisture may freeze the brakes.

3. If a rudder gust lock is not available, caster the nosewheel to the extreme left or right positions.
4. Install pitot tube cover(s) if available.
5. Set elevator, aileron and rudder trim tabs to neutral, so the trim tabs fair with the control surfaces.
6. Use ropes or chains of at least 700 pounds tensile strength. Secure the nose gear with a rope attached above the nose gear torque link. The other end should be attached to a substantial ground anchor. The rope angle to the ground should be 45 degrees. Attach a second rope in a similar manner to the opposite side of the nose gear. Secure the tail tie-down fitting in a similar manner. Do not impose side loads on the tie-down fitting.

JACKING AND LEVELING

Three jack points are provided on the underside of the airplane; one is located just aft of the nose wheel well, and one is located on the lower surface of each wing, just aft of the main gear attach points.

NOTE

- To prevent the flight hour recorder from recording while the airplane is on jacks and battery switch is in the ON position, remove fuse located in the side console. Reinstall fuse when finished.
- Special two-ton jacks, ideally suited to the 310R can be supplied by the Cessna Aircraft Company. Three jacks are required to lift the airplane.

To level the airplane longitudinally and laterally, use the three jacking points provided on the airplane. Level longitudinally by backing out the two screws at "Level Point" on the left outside fuselage at Stations 88.90 and 59.10 and place a spirit level on these screws, then level longitudinally. To level laterally, place a spirit level centered on the outside skin along the rear spar on the underside of fuselage. Refer to the Airplane Service Manual for additional information.

FLYABLE STORAGE

Flyable storage applies to all airplanes which will not be flown for an indefinite period but which are to be kept ready to fly with the least possible preparation. If the airplane is to be stored temporarily, or indefinitely, refer to the Airplane Service Manual for proper storage procedures.

Airplanes which are not in daily flight should have the propellers rotated, by hand, six revolutions at least once each week. In damp climates and in storage areas where the daily temperature variation can cause condensation, propeller rotation should be accomplished more frequently. Rotating the propeller 45° to 90° from its original position redistributes residual oil on the cylinder walls, crankshaft and gear surfaces and repositions the pistons in the cylinders, thus preventing corrosion. Rotate propellers as follows:

1. Throttles - IDLE.
2. Mixtures - IDLE CUT-OFF.
3. Magneto Switches - OFF.
4. Propellers - ROTATE CLOCKWISE. Manually rotate propellers six revolutions, standing clear of arc of propeller blades. Stop propeller 45° to 90° from its original position.

Keep fuel tanks full to minimize condensation in the fuel tanks. Maintain battery at full charge to prevent electrolyte from freezing in cold weather. If the airplane is stored outside, tie-down airplane in anticipation of high winds. Secure airplane as follows:

1. Secure rudder with the optional rudder gust lock or with a control surface lock over the fin and rudder. If a lock is not available, caster the nosewheel to the full left or right position.
2. Install control column lock in pilot's control column, if available. If column lock is not available, tie the pilot's control wheel full aft with a seat belt.
3. Tie ropes or chains to the wing tie-down fittings located on the underside of each wing. Secure the opposite ends of the ropes or chains to ground anchors. Chock the main landing gear tires; do not set the parking brake if a long period of inactivity is anticipated as brake seizing can result.
4. Secure a rope (no chains or cables) to the upper nose gear trunnion and secure opposite end of rope to a ground anchor. Chock the nose landing gear tire.
5. Secure the middle of a rope to the tail tie-down fitting. Pull each end of rope at a 45-degree angle and secure to ground anchors at each side of the tail.
6. At the end of 30 days, the airplane should be flown for 30 minutes until oil and cylinder temperatures reach normal operating range. If the airplane is not flown at the end of 30 days, the airplane should be placed in temporary or indefinite storage.

SERVICING**NOTE**

Refer to the Airplane Service Manual for complete servicing requirements.

FUEL (Aviation Grade 100/130 Minimum - Green Color)

Low lead aviation grade 100LL (Blue Color) is a suitable alternate. Service after each flight. Keep full to retard condensation in the tanks. Tank capacities are:

- Each Main Tank - 51.0 Gallons
- Each Optional Auxiliary Tank - 20.5 Gallons (40-Gallon Option)
- Each Optional Auxiliary Tank - 32.0 Gallons (63-Gallon Option)
- Each Optional Wing Locker Tank - 20.5 Gallons

Isopropyl alcohol may be added to the fuel supply in quantities not to exceed 1% of the total. Refer to Fuel Additive paragraphs in this section for additional information.

WARNING

- Do not operate any avionics or electrical equipment on the airplane during fueling. Do not allow open flame or smoking in the vicinity of the airplane while fueling.
- During all fueling operations, fire fighting equipment must be available. Two ground wires from different points on the airplane to separate approved grounding stakes shall be used.

Fuel Additive

Strict adherence to recommended preflight draining instructions as called for in Section 4 will eliminate any free water accumulations from the tank sumps. While small amounts of water may still remain in solution in the gasoline, it will normally be consumed and go unnoticed in the operation of the engine.

One exception to this can be encountered when operating under the combined effect of: 1) use of certain fuels, with 2) high humidity conditions on the ground 3) followed by flight at high altitude and low temperature (flight levels of 20,000 feet or above and temperatures of -28.9°C (-20°F) or below). Under these unusual conditions small amounts of water in solution can precipitate from the fuel stream and freeze in sufficient quantities to induce partial icing of the engine fuel injection system.

While these conditions are quite rare and will not normally pose a problem to owners and operators, they do exist in certain areas of the world and consequently must be dealt with, when encountered.

Therefore, to alleviate the possibility of fuel icing occurring under these unusual conditions it is permissible to add isopropyl alcohol or ethylene glycol monomethyl ether (EGME) compound to the fuel supply.

The introduction of alcohol or EGME compound into the fuel provides two distinct effects: 1) it absorbs the dissolved water from the gasoline and 2) alcohol has a freezing temperature depressant effect.

Alcohol, if used, is to be blended with the fuel in a concentration of 1% by volume. Concentrations greater than 1% are not recommended since they can be detrimental to fuel tank materials.

The manner in which the alcohol is added to the fuel is significant because alcohol is most effective when it is completely dissolved in the fuel. To insure proper mixing the following is recommended:

1. For best results the alcohol should be added during the fueling operation by pouring the alcohol directly on the fuel stream issuing from the fueling nozzle.

ALCOHOL - FUEL MIXING RATIO CHART

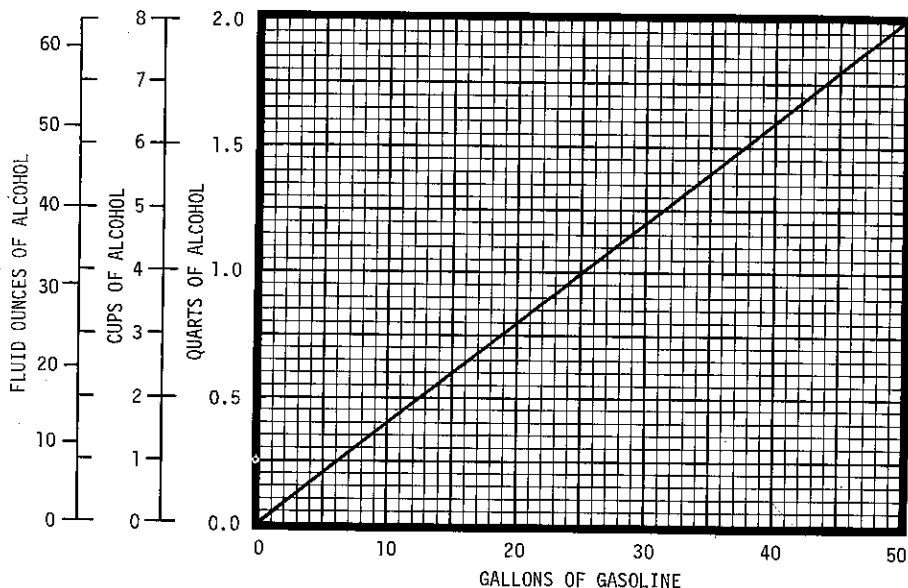

Figure 8-1

2. An alternate method that may be used is to premix the complete alcohol dosage with some fuel in a separate clean container (approximately 2-3 gallon capacity) and then transferring this mixture to the tank prior to the fuel operation.

Any high quality isopropyl alcohol may be used, such as:

Anti-icing fluid (MIL-F-5566) or
Isopropyl alcohol (Federal Specification TT-I-735a).

Figure 8-1 provides alcohol-fuel ratio mixing information.

Ethylene glycol monomethyl ether (EGME) compound in compliance with MIL-I-27686 or Phillips PFA-55MB, if used, must be carefully mixed with the fuel in concentrations not to exceed 0.15% by volume.

CAUTION

- Mixing of the EGME compound with the fuel is extremely important because concentration in excess of that recommended (0.15 percent by volume maximum) will result in detrimental affects to the fuel tanks, such as deterioration of protective primer and sealants and damage to O-rings and seals in the fuel system and engine components. Use only blending equipment that is recommended by the manufacturer to obtain proper proportioning.
- Do not allow the concentrated EGME compound to come in contact with the airplane finish or fuel cell as damage can result.

Prolonged storage of the airplane will result in a water buildup in the fuel which "leeches out" the additive. An indication of this is when an excessive amount of water accumulates in the fuel tank sumps. The concentration can be checked using a differential refractometer, manufactured by the Seiscor Corporation, Tulsa, Oklahoma. It is imperative that the technical manual for the differential refractometer be followed explicitly when checking the additive concentration.

OIL (Aviation Grade Engine Oil; SAE 50 Above 4.4°C (40°F), SAE 30 Below 4.4°C (40°F) or Multiviscosity Unrestricted Temperature Range - Filter 623427)

Multiviscosity oil is recommended for use after the first 25 hours of engine operation for improved starting in temperatures below 44°C (40°F). When operating temperatures overlap indicated ranges, use the lighter grade of oil. Ashless dispersant oil, conforming to Continental Motors Specification MHS-24, must be used. No oil additives are approved for use. Change oil and filter every 100 hours or 6 months, whichever occurs first. Reduce intervals for prolonged operation in dusty areas, cold climates, or when short flights and long idle periods result in sludging conditions.

NOTE

For faster ring seating and improved oil control, your Cessna was delivered from the factory with corrosion preventive oil conforming to MIL-C-6529, Type II. This break-in oil must be used only for the first 25 hours of operation; at that time it must be replaced with ashless dispersant oil. If oil must be added during this first 25 hours of operation, use straight mineral oil conforming to MIL-L-6082.

Check oil level before each flight. Do not operate on less than 9 quarts. To minimize loss of oil through breather, fill to 10-quart level for normal flights of less than 3 hours. For extended flight, fill to capacity which is 13 quarts for each engine sump including 1 quart for oil filter.

OXYGEN (Aviators Breathing Oxygen - Specification MIL-O-27210)

Check pressure gage for anticipated requirements before each flight. Refill whenever pressure drops below 300 PSI.

OXYGEN SERVICING CHART

AMBIENT TEMPERATURE		FILLING PRESSURE PSIG	AMBIENT TEMPERATURE		FILLING PRESSURE PSIG
°C	°F		°C	°F	
-17.8	0	1600	21.1	70	1925
-12.2	10	1650	26.7	80	1950
-6.7	20	1675	32.2	90	2000
-1.1	30	1725	37.8	100	2050
4.4	40	1775	43.3	110	2100
10.0	50	1825	48.9	120	2150
15.6	60	1875	54.4	130	2200

THE NUMBERS SHOWN ABOVE ARE APPLICABLE TO 1800 PSI OXYGEN BOTTLES. IF AN 1850 PSI OXYGEN BOTTLE IS INSTALLED, INCREASE EACH FILLING PRESSURE BY 50 PSI.

Figure 8-2

The oxygen cylinders, when fully charged and allowed to stabilize at a temperature of 21.1°C (70°F), contain approximately 48.3 cubic feet of oxygen, under a pressure of 1800 PSI or 76.6 cubic feet of oxygen under a pressure of 1850 PSI. Filling pressures will vary, however, due to the ambient temperature in the filling area, and because of the temperature rise resulting from compression of the oxygen. Because of this, merely filling to 1800 or 1850 PSI will not result in a properly filled cylinder. Fill to the pressures indicated in Figure 8-2 for the ambient temperature.

WARNING

Oil, grease, or other lubricants in contact with oxygen create a serious fire hazard, and such contact must be avoided when handling oxygen equipment.

The oxygen cylinder is serviced through a filler valve located inside the nose baggage bay on the aft baggage bay bulkhead.

ALCOHOL WINDSHIELD DEICE RESERVOIR (Isopropyl Alcohol MIL-F-5566)

Check reservoir fluid level; fill as required. Reservoir capacity is 3.0 gallons.

TIRES

Tire pressure should be maintained at 60 PSI for the main wheel tires and 40 PSI for the nosewheel tire.

AIRPLANE CLEANING AND CARE

PAINTED SURFACES

The painted exterior surfaces of your new airplane require an initial curing period which may be as long as 90 days after the finish is applied. During this curing period some precautions should be taken to avoid damaging the finish or interfering with the curing process. The finish should be cleaned only by washing with clean water and mild soap, followed by a rinse water and drying with cloths or a chamois. Do not use polish or wax, which would exclude air from the surface, during this 90-day curing period. Do not rub or buff the finish and avoid flying through rain, hail or sleet.

Once the finish has cured completely, it may be waxed with a good automotive wax. A heavier coating of wax on the leading edges of the wings, tail, engine nose cap and propeller spinner will help reduce the abrasion encountered in these areas.

PROPELLER

Preflight inspection of propeller blades for nicks and wiping them occasionally with an oily cloth to clean off grass and bug stains will assure long, trouble-free service. It is vital that small nicks on the

propeller, particularly near the tips and on the leading edges, are dressed out as soon as possible since these nicks produce stress concentrations, and if ignored, may result in cracks. Never use an alkaline cleaner on the blades; remove grease and dirt with Stoddard solvent. Do not feather the propellers below 700 RPM as this may damage the hub mechanism.

LANDING GEAR

Cessna Dealer's mechanics have been trained in the proper adjustment and rigging procedures of the landing gear system. To assure trouble-free gear operation, have your Cessna Dealer check the gear regularly and make any necessary adjustments. Only properly trained mechanics should attempt to repair or adjust the landing gear components and system.

DEICE BOOTS

The optional deice boots have a special, electrically conductive coating to bleed-off static charges which cause radio interference and may perforate the boots. Fueling and other servicing operations should be done carefully, to avoid damaging this conductive coating or tearing the boots.

To prolong the life of surface and propeller deice boots, they should be washed and serviced on a regular basis. Keep the boots clean and free from oil, grease and other solvents which cause rubber to swell and deteriorate. Outlined below are recommended cleaning and servicing procedures.

CAUTION

Use only the following instructions when cleaning boots. Disregard instructions which recommend petroleum base liquids (Methyl-Ethyl-Ketone, non-leaded gasoline, etc.) which can harm the boot material.

Clean the boots with mild soap and water, then rinse thoroughly with clean water.

NOTE

Isopropyl alcohol can be used to remove grime which cannot be removed using soap. If isopropyl alcohol is used for cleaning, wash area with mild soap and water, then rinse thoroughly with clean water.

To possibly improve the service life of deice boots and to reduce the adhesion of ice, it is recommended that the deice boots be treated with AGE MASTER No. 1 and ICEX.

AGE MASTER No. 1, used to protect the rubber against deterioration from ozone, sunlight, weathering, oxidation and pollution, and ICEX, used to help retard ice adhesion and for keeping deice boots looking new longer, are both products of and recommended by B. F. Goodrich.

The application of both AGE MASTER No. 1 and ICEX should be in accordance with the manufacturer's recommended directions as outlined on the containers.

CAUTION

- Protect adjacent areas, clothing, and use plastic or rubber gloves during applications, as AGE MASTER No. 1 stains and ICEX contains silicone which makes paint touchup almost impossible.
- Ensure that the manufacturer's warnings and cautions are adhered to when using AGE MASTER No. 1 and ICEX.

Small tears and abrasions in surface deice boots can be repaired temporarily without removing the boots, and the conductive coating can be renewed. Your Cessna Dealer has the proper materials and know-how to do this correctly.

ENGINES

The engine compartments should be cleaned, using a suitable solvent. Most efficient cleaning is done using a spray-type cleaner. Before spray cleaning, insure protection is afforded for components which might be adversely affected by the solvent. Refer to the Airplane Service Manual for proper lubrication of controls and components after engine cleaning.

INTERIOR CARE

To remove dust and loose dirt from the upholstery, headliner and carpet, clean the interior regularly with a vacuum cleaner.

Blot up any spilled liquid promptly with cleansing tissue or rags. Don't pat the spot; press the blotting material firmly and hold it for several seconds. Continue blotting until no more liquid is taken up. Scrape off sticky materials with a dull knife, then spot-clean the area.

Oily spots may be cleaned with household spot removers, used sparingly. Before using any solvent, read the instructions on the container and test it on an obscure place on the fabric to be cleaned. Never saturate the fabric with a volatile solvent; it may damage the padding and backing materials.

WARNING

- Use all cleaning agents in accordance with the manufacturer's recommendations.
- The use of toxic or inflammable cleaning agents is discouraged. If these cleaning agents are used, insure adequate ventilation is provided to prevent harm to the user and/or damage to the airplane.

Soiled upholstery and carpet may be cleaned with foam-type detergent, used according to the manufacturer's instructions. To minimize wetting the fabric, keep the foam as dry as possible and remove it with a vacuum cleaner.

The plastic trim, instrument panel and control knobs need only be wiped with a damp cloth. Oil and grease on the control wheel and control knobs can be removed with a cloth moistened with kerosene. Volatile solvents, such as mentioned in paragraphs on care of the windshield, must never be used since they soften and craze the plastic.

WINDOWS AND WINDSHIELDS

The plastic windshield and windows should be kept clean and waxed at all times. To prevent scratches and crazing, wash them carefully with plenty of soap and water, using the palm of the hand to feel and dislodge dirt and mud. A soft cloth, chamois or sponge may be used, but only to carry water to the surface. Rinse thoroughly, then dry with a clean, moist chamois. Rubbing the surface of the plastic with a dry cloth builds up an electrostatic charge which attracts dust particles in the air. Wiping with a moist chamois will remove both the dust and this charge.

CAUTION

Applying localized heat to a windshield equipped with an optional electrical anti-ice panel may distort or damage the windshield anti-ice panel.

Remove oil and grease with a cloth moistened with kerosene. Never use gasoline, benzine, acetone, carbon tetrachloride, fire extinguisher fluid, lacquer thinner or glass cleaner. These materials will soften the plastic and may cause it to craze.

After removing dirt and grease, if the surface is not badly scratched, it should be waxed with a good grade of commercial wax. The wax will fill in minor scratches and help prevent further scratching. Apply a thin, even coat of wax and bring it to a high polish by rubbing lightly with a clean, dry, soft flannel cloth. Do not use a power buffer; the heat generated by the buffing pad may soften the plastic.

Do not use a canvas cover on the windshield unless freezing rain or sleet is anticipated. Canvas covers may scratch the plastic surface.

OXYGEN MASKS

The pilot's mask is a permanent type mask, while the remainder are the semipermanent type. They may be cleaned with alcohol or used as disposable masks. Additional masks and hose assemblies are available from your Cessna Dealer.

ASPEN AVIONICS

Aspen Avionics, Inc.
5001 Indian School NE
Albuquerque, NM 87110 USA

FAA APPROVED
AIRPLANE FLIGHT MANUAL SUPPLEMENT
or
SUPPLEMENTAL AIRPLANE FLIGHT MANUAL
for the
ASPEN AVIONICS EVOLUTION FLIGHT DISPLAY SYSTEM
EFD1000 PRIMARY FLIGHT DISPLAY
Optionally with
EFD1000 AND/OR EFD500 MULTI-FUNCTION DISPLAYS

The information contained in this Supplement must be attached to the FAA Approved Airplane Flight Manual or placed with the Pilot's Operating Handbook or other operating information when the Aspen EFD1000 PFD and optionally the Aspen EFD1000 MFD and/or EFD500 MFD are installed in accordance with AML STC SA10822SC. This document must be carried in the aircraft at all times.

The information in this Supplement supplements or supersedes the information in the FAA Approved Airplane Flight Manual or other operating information only as set forth herein.

For limitations, procedures, and performance data not contained in this Supplement, consult the Airplane Flight Manual or other operating information.

Airplane Make: CESSNA
Airplane Model: 310R
Airplane Registration Number: VH-~~XXXX~~ JTV
Airplane Serial Number: 316R0712

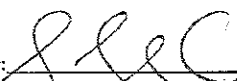
FAA APPROVED By: 
S. Frances Cox, Manager
Ft. Worth Special Certification Office
Federal Aviation Administration
Fort Worth, TX 76137-4298
DATE APPROVED: July 14, 2010

DOCUMENT REVISIONS

Document Revision	Pages Revised	Description of Change	FAA Approval Date	ECO
()	All	Internal Release		1775
A	All	Initial Release for FAA Approval	9/28/2009	1784
B	All	Added PFD Pilot information and winds aloft speed limit.	12/10/2009	1847
C	All	Added AMMD and Charts information to the Databases, Hazard Awareness Limitations and the Warning, Caution and Advisory Sections. Updated the software version section. Updated Acronyms and Abbreviations.	4/12/2010	1950
D	All	Added Level B/Class III aircraft information. Clarified databases intended function. Added Ownship on Instrument Approach Charts information. Improved formatting.		2074
E	All	Added electronic placard information in Section 2.10. Removed ownship on instrument Approach Charts information	7/7/2010	2092
F	All	Added ownship on instrument Approach Charts Limitation information	7/14/2010	2113
<p>FAA APPROVED By:</p>  <p>S. Francis Cox, Manager Ft. Worth Special Certification Office Federal Aviation Administration Fort Worth, TX 76137-4288</p>				
<i>Prepared By:</i>	WCB	<i>Reviewed By:</i>	PAH	See ECO Record For Release Authorization

TABLE OF CONTENTS

1	General	5
1.1	System Overview	5
1.2	Installed Equipment Configuration Matrix	7
2	Limitations	10
2.1	Pilot's Guide	10
2.2	Software Versions	10
2.3	Airspeed Limitation	10
2.4	Pitot Obstruction Monitor	11
2.5	Databases (EFD1000/500 MFD Only)	11
2.6	RSM GPS Usage (if installed)	13
2.7	Operation on Internal Battery or EBB	13
2.8	Emergency Backup Battery (EFD1000 MFD Only)	14
2.9	Geographic Limitation	14
2.10	Placards and Decals	15
2.11	Seaplane Operation	15
2.12	Hazard Awareness Limitations (EFD1000 PFD PRO and MFDs ONLY)	16
2.13	Kinds of Operations Equipment List (KOEL)	19
2.13	Kinds of Operations Equipment List (KOEL)	19
3	Emergency and Abnormal Procedures/Conditions	20
3.1	Pitot/Static System Blockage	20
3.2	CROSS CHECK ATTITUDE Message	20
3.3	ADAHRS Attitude Disagreement	21
3.4	MFD Reversionary Mode Operation (EFD1000 MFD only)	21
3.5	In-Flight ADAHRS Reset	22
3.6	Alternator or Generator Failure, or ON BAT Annunciation	23
3.7	Abnormal Shutdown Procedure	24
3.8	EBB Disconnect (EFD1000 MFD only)	24
3.9	Power Override	25
3.10	EFD1000/500 Intercommunications Failure	25
3.11	Loss of GPS information	26
3.12	MFD Database Card	27
3.13	Warning, Caution, and Advisory Summary	28
4	Normal Procedures	37
4.1	Exterior Inspection	37
4.2	Before Taxi Checks	37
4.3	Before Take-Off Checks	38
4.4	Before Approach Checks	39
4.5	Shutdown Checks	39
5	Performance	40
6	Weight & Center of Gravity	40
7	EFD1000/500 System Operation	40
8	List of Acronyms and Abbreviations	41

INTENTIONALLY LEFT BLANK

1 General

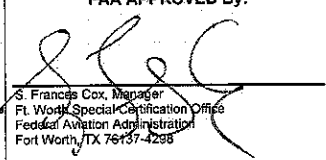
1.1 System Overview

This Airplane Flight Manual Supplement (AFMS) applies to aircraft installations of the following possible display combinations:

- EFD1000 Level B PFD Pro or EFD1000 PFD Pro
- EFD1000 Level B PFD Pro or EFD1000 PFD Pro, and EFD500 MFD
- EFD1000 Level B PFD Pro or EFD1000 PFD Pro, and EFD1000 MFD
- EFD1000 Level B PFD Pro or EFD1000 PFD Pro, and EFD1000 MFD and EFD500 MFD
- EFD1000 PFD Pilot
- EFD1000 PFD Pilot and EFD500 MFD

The Evolution Flight Display System is a multi-display, highly capable Electronic Flight Instrument System (EFIS) with integral Micro Electromechanical Systems (MEMS)-based Air Data Attitude and Heading Reference System (ADAHRS) with either internal backup battery or external Emergency Backup Battery (EBB). The system offers a state-of-the-art Primary Flight Display (PFD) with Attitude/Flight Director, and HSI/two-pointer RMI, combined with mapping, satellite weather, traffic and Stormscope[®] overlays. When combined with the optional EFD1000 MFD and/or EFD500 MFD, the system offers a multi-panel, Multi-Function Display (MFD) solution that displays high resolution moving maps with Jeppesen[®] enroute and terminal data, satellite weather information, Stormscope data, traffic sensor data, relative terrain depictions, secondary attitude information, and a secondary HSI display. In addition, at the push of a button the EFD1000 MFD can instantly revert to a fully-functional primary flight display generated from ADAHRS data completely independent of that generated by the PFD. When combined with the optional Emergency Backup Battery the EFD1000 PFD and MFD combination provides an unsurpassed level of reliability and safety, and has FAA approval to replace mechanical airspeed and altitude instruments traditionally required with previous generation EFIS systems.

The EFD1000 Pilot PFD is a Primary Flight Display (PFD) with Attitude indicator, heading indicator and moving map. The Pilot PFD does not interface with weather or traffic data, and cannot be installed with an EFD1000MFD.

The Level B EFD1000 PFD provides a higher level of software integrity, primarily for certification on higher-performance (Class III¹) aircraft. The Level B PFD does not interface with weather or traffic data, and can be installed with an EFD1000 MFD and/or an EFD500.

The EFD1000 Pilot PFD is a Primary Flight Display (PFD) with Attitude indicator, heading indicator and moving map. The Pilot PFD does not interface with weather or traffic data, and cannot be installed with an EFD1000 MFD.

The EFD500 is a fully functional MFD with all the capability of the EFD1000 MFD except reversion, HSI, Remote Sensor Module (RSM), Emergency Backup Battery, Cross Link information (receive only) and the air data, attitude and heading features.

The standard internal battery in the EFD1000 or EFD500 is capable of providing 30 or more minutes of operation at typical cockpit temperatures if aircraft power to the system fails. An optional Emergency Backup Battery (EBB) available for the EFD1000 MFD provides a guaranteed 30 minutes of emergency operation, even under extreme environmental conditions, when maintained as required by the installation Manual (900-00003-001). Typical EBB endurance at 25°C is two or more hours, depending on the backlight intensity.

When the EFD1000 MFD with Emergency Backup Battery is used to replace backup altimeter and airspeed indicators the battery condition must be verified prior to each flight.

¹ FAA Advisory Circular 23-1309-1D defines a Class III aircraft as typically Single Reciprocating Engine, Single Turbine Engine, Multiple Reciprocating Engine and Multiple Turbine Engine equal or over 6000 pounds Maximum Certificated Gross Takeoff Weight.

Figure 1 provides a block diagram of a complete EFD1000/500 system installation, including optional interfaces. See section 1.2 for a list of equipment installed in your aircraft.

For detailed information on the operation of the EFD1000 PFD please refer to Aspen Avionics document 091-00005-001, EFD1000 PFD Pilot's Guide. For additional information about the EFD1000/500 MFD, please refer to Aspen Avionics document 091-00006-001, EFD1000/500 MFD Pilot's Guide. These documents must be carried in the aircraft whenever an EFD1000 PFD and/or EFD1000/EFD500 MFD are installed in the airplane.

EFD1000 Pilot Features. Refer to the Pilot's Guide for detailed information:

- o Airspeed and Altitude Tapes
- o Integral Altitude Alerter (visual only; no audible alert)
- o Slaved heading indicator with heading Bug
- o Base map with flight plan legs and waypoints
- o 360° and arc view
- o GPS Groundspeed, OAT and TAS
- o Display of calculated winds aloft
- o Integral Air data computer and Attitude Heading Reference System (ADAHRS)
- o Built in backup battery and available emergency GPS
- o Brilliant Display
- o The Pilot can only be configured for only one GPS navigator

The EFD1000 Pro Features include the features of the EFD Pilot plus:

- o Full slaved Electronic HSI with dual bearing pointers in lieu of the slaved heading indicator
- o Integrates with most GA autopilot and Flight Director systems
- o Dual GPS and dual VHF Nav support
- o Built-in GPS Steering, (with compatible GPS navigator)
- o Approach minimums alerting
- o Optional Traffic and Weather interfaces

1.2 Installed Equipment Configuration Matrix

The table below records the equipment and optional interfaces installed in your aircraft, and will be completed during installation by the installation facility. The table is marked with the specific equipment that is installed in your aircraft, and shows what external interfaces have been installed, such as traffic and weather, and to which EFD the data is provided.

Please refer to this sheet to determine which portions of this AFMS are applicable to your specific aircraft installation:

NOTE: These tables are to be completed by the Avionics Installer

	EFD500 MFD	EFD1000 PFD PRO	EFD1000 PFD PILOT	Level B EFD1000 PFD	EFD1000 MFD
Installed Evolution Flight Displays		✓	✓		
RSM with GPS	N/A	✓	✓		
RSM without GPS, top mount	N/A				
RSM without GPS, bottom mount	N/A				
EBB Emergency Backup Battery	Not Authorized	Not Authorized	Not Authorized	Not Authorized	
Traffic Interface		✓	Not Available	Not Available	
Stormscope [®] Interface		✓	Not Available	Not Available	
XM Weather Interface (Requires optional EWR50)			Not Available	Not Available	
Charts		Not Available	Not Available	Not Available	

Table 1 Installed Equipment Configuration

Backup Attitude Indicator	YES (Required)	
	Emergency Backup Battery	Vacuum
Backup Attitude Power Source		
Standby Airspeed Indicator	NO*	YES
Standby Altimeter	NO*	YES

Table 2 Backup Instruments Configuration

*An operational EBB Emergency Backup Battery connected to an EFD1000 MFD is required unless a standby Airspeed indicator and a standby Altimeter are installed. See Section 1.1 and Table 4.

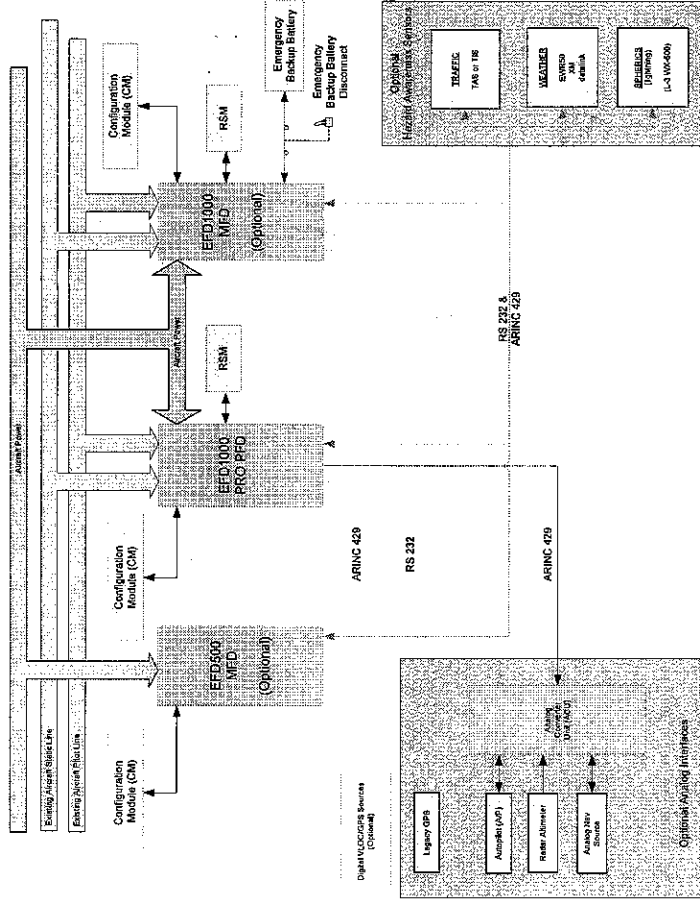

Figure 1 – Block Diagram of the EFD1000 Pro PFD, EFD1000MFD and EFD500MFD System with Optional Interfaces.
 NOTE: The Level B EFD1000 PFD is not connected to the Optional Hazard Awareness Sensors.

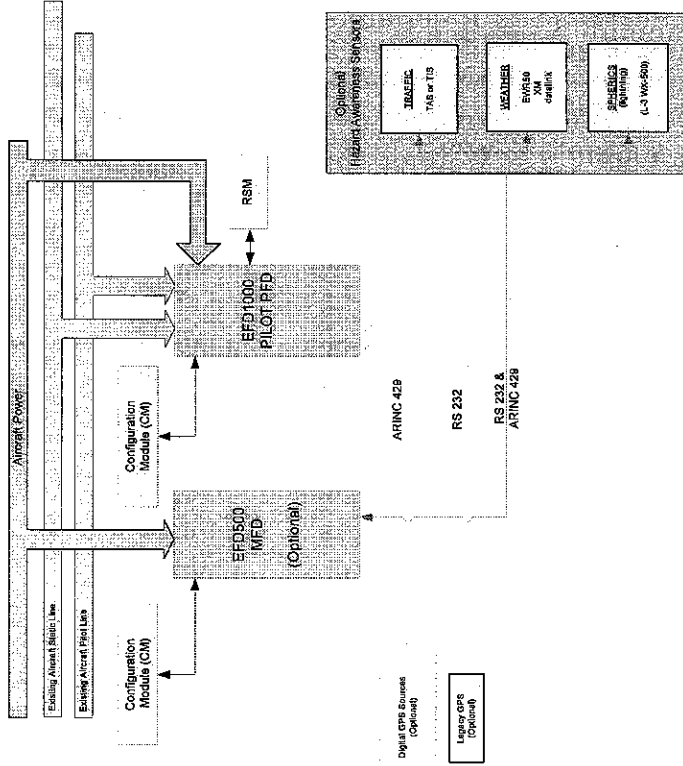

Figure 2 Block Diagram of EFD1000 Pilot PFD System with Optional EFD600

2 Limitations

2.1 Pilot's Guide

Limitation: Aspen Avionics document 091-00005-001, EFD1000 PFD Pilot's Guide must be carried in the aircraft and be available to the flight crew.

Limitation: For installations that include the optional EFD1000 MFD or EFD500 MFDs, Aspen Avionics document 091-00006-001, EFD1000/500 MFD Pilot's Guide must be carried in the aircraft and be available to the flight crew.

2.2 Software Versions

Limitation: The EFD1000/500 display must use the software versions listed below, or later FAA approved versions.

The EFD1000 and EFD500 use identical software source code. A license key "image" stored in the unit Configuration Module determines the associated operating mode (i.e. PFD, MFD) and enabled features (i.e. weather, traffic) of the connected EFD hardware.

The EFD software version is displayed on the Main Menu System Status page. Refer to Table 1 Installed Equipment Configuration, to determine the configuration of this aircraft.

System Component	Software Name	Version 2.X Software Version (or subsequent)
EFD1000 (PFD or MFD) and EFD500 MFD	MAP	2.1
	IOP	2.0
EFD1000 Level B Pro (PFD)	MAP	B2.1
	IOP	B2.0

2.3 Airspeed Limitation

Limitation: The maximum approved operating airspeed for this system is 270 KIAS (311 MPH IAS).

2.4 Pitot Obstruction Monitor

Limitation: For aircraft with two EFD1000 displays, an IFR GPS must be operable for dispatch under IFR.

NOTE:

This limitation applies only to aircraft with both an EFD1000 PFD and an EFD1000 MFD, regardless of the standby instrument configuration

Most light aircraft have only a single pitot and static system available for flight instrument use. As such, a common pitot and static input is shared between the EFD1000 PFD and the EFD1000 MFD. Should one or both of these lines become blocked, such as might occur due to an inadvertent icing encounter or from water trapped in the lines, then both the EFD1000 PFD and the EFD1000 MFD, along with any installed standby indicators of airspeed and altitude, could display erroneous airspeed and altitude information.

Furthermore, because the EFD1000 uses pitot and static pressures as part of the ADAHRS attitude solution, loss or corruption of the pitot or static pressures could also influence the accuracy of attitude information.

The EFD1000 has been shown to be robust to these failures, either by being tolerant to incorrect pitot or static inputs, or by detecting and annunciating a degraded attitude solution. When connected to an IFR certified GPS, the system evaluates indicated airspeed and GPS groundspeed to identify conditions indicative of a blockage in the pitot system. If a blockage is detected the monitor will fail the attitude solution, post red X's in place of the attitude and heading information, and present a "CHECK PITOT HEAT" message as a reminder to the pilot to check for ice accumulating on the pitot probe. An "ATTITUDE FAIL" annunciation will accompany the "CHECK PITOT HEAT" amber annunciation, and will be presented when indicated airspeed is less than 30 KIAS (35 mph) and GPS groundspeed is greater than 50 kts (58 mph).

Once the system detects that the pitot obstruction has been cleared, the "CHECK PITOT HEAT" annunciation is removed and the system automatically performs an ADAHRS in flight reset.

Should a GPS failure be experienced in flight, the Pitot Obstruction Monitor continues to operate in a fail safe mode and will continue to detect obstructions in the pitot system that might occur. However, post landing the monitor remains active and as the airplane slows below 30 KIAS the system will post a red X in place of the attitude and heading information and post the "CHECK PITOT HEAT" message. In this circumstance, restoring the GPS system, or cycling power to the affected EFD1000, will restore normal monitor operation.

In some aircraft with very low stall speeds it may be possible to activate the Pitot Obstruction Monitor when performing slow flight at indicated airspeeds below 30 KIAS. Under these circumstances if the groundspeed exceeds 50kts the monitor will activate. Should this occur, fly by reference to the standby attitude indicator or the visual horizon. To restore normal ADAHRS operation, increase the indicated airspeed to a value greater than 30 KIAS; the affected display will then perform an automatic reset.

This Pitot Obstruction Monitor is not available in installations without a GPS. An IFR approved GPS is required for installations with two EFD1000 displays.

2.5 Databases (EFD1000/500 MFD Only)

There are several databases available (see Table 3). Jeppesen provides terrain, NavData[®], cultural information and obstacle data. The intended function of each of these databases is to provide a background graphical depiction of the surrounding map features used to improve the flight crew awareness of the aircraft ownship position relative to other items depicted on the moving map. The background graphical depiction of the surrounding map features is not to be used for navigation and must

not be used as a basis for maneuvering.

The overlaid flight plan originates from the GPS and can be used for navigation within the limitations of the GPS approval.

The EFD1000 PFD does not use a database.

Limitation: Database currency date must be acknowledged on the EFD1000 MFD and EFD500 MFD prior to each flight. Flight with an expired database is not recommended. Any out of date data displayed on the EMD must either a) be verified to be correct by the flight crew before use or b) not be used.

Limitation: Legend information, as well as climb and descent tables, MLS frequency pairing and general data that are found in the NACO paper Terminal Procedures Volumes are not provided in the Charts Database. The operator is responsible for access to this information as required by regulation.

The Jeppesen NavData[®], Cultural database and Obstacle database are all combined into a single download from Jeppesen. Terrain data is loaded at the factory and does not require periodic updating. The terrain database is available from Jeppesen.

The Terminal Procedures Charts (Charts) database updates are provided by Seattle Avionics.

Data base valid dates for Jeppesen and Charts are displayed at power up and require a pilot action to acknowledge. Database valid date information can also be accessed via the main menu of the MFD.

NOTE:

**Flight with an expired database is not recommended.
An expired database does not prevent terrain or other Nav Map features from being displayed on the MFD**

Database Type	Includes	Update Cycle	Database Provider	Limitations
Terrain	High resolution terrain data for Americas, International, or Worldwide geographic regions. Terrain depiction is limited to the region between 65 deg N latitude to 65 deg South latitude	Delivered with unit, updated as desired	Jeppesen mail order	These databases are intended to improve flight crew awareness and are not to be used for navigation.
NavData	Includes Navaids, Controlled Airspace, Restricted, Prohibited and Special Use Airspace, Airports, etc.	28 day update cycle	Jeppesen JSUM®	
Cultural	Includes Roads, Rivers, Railroads, Political boundaries, Cities, etc.	28 day update cycle	Jeppesen JSUM®	
Obstacles	Includes man made obstacles greater than 250 ft. AGL. This database relies upon data reported by government agencies and may not include all obstacles due to inherent reporting and processing delays in the data. In addition, obstacle data may not be available for all regions within the data card coverage area.	28 day update cycle	Jeppesen JSUM®	
Charts	NACO Terminal Procedures Charts	28 day update cycle	Seattle Avionics	

Table 3 Database Listing and Descriptions

2.6 RSM GPS Usage (if installed)

Limitation: The RSM GPS is limited to EMERGENCY USE ONLY.

The EFD1000 RSM can optionally include a non-certified GPS receiver. This GPS can provide positioning data when all other approved sources of GPS data have failed. Position data from the RSM GPS will only become available for use following a loss of position information from all other connected GPS system(s). When the RSM GPS is in use, the current flight plan leg will be shown in white rather than magenta, and a message is presented limiting the RSM GPS to EMERGENCY USE ONLY.

2.7 Operation on Internal Battery or EBB

Limitation: Takeoff with aircraft voltage (as indicated on the EFD) below 12.3V (14V electrical system) or 24.6V (28V electrical system) is NOT AUTHORIZED.

Each EFD1000 or EFD500 is equipped with either an internal battery, or an external Emergency Backup Battery. Battery operation and logic is the same regardless of which battery is connected to your display. The Emergency Backup Battery has a wider operating temperature envelope than the internal battery, and will provide battery capacity for significantly longer than the internal battery.

The EFD system incorporates sophisticated power logic to determine when to transition to battery. On

the ground, the system will turn on and turn off with the application or removal of aircraft power. In the air, the system will transition to battery if aircraft power is removed or degraded. Transition thresholds and times will vary as a function of the input voltage to the display, which can be observed via the Menu Power Settings Page. Battery operation should be expected any time the aircraft charging system is unable to maintain a voltage at the EFD of 12.3 V (14V electrical system) or 24.6V (28V electrical system). Under these circumstances, should the aircraft dispatch the EFD will transition to battery shortly after reaching flying speed.

2.8 Emergency Backup Battery (EFD1000 MFD Only)

Limitation: Dispatch when EBB charge status of less than 80% is NOT AUTHORIZED if the EBB is required by the KOEL in section 2.12.7

Dispatch with a cabin temperature below -20°C is NOT AUTHORIZED if the EBB is required by the KOEL in section 2.12.7.

The Emergency Backup Battery is an approved emergency power source for the EFD1000 MFD. When installed, the EBB enables the EFD1000 MFD to be the approved backup instrument to the EFD1000 PFD, and authorizes removal of independently-powered standby airspeed and altitude instruments. When maintained in accordance with the Installation Manual (annual check and scheduled replacement per 900-00003-001) and the EFD1000 MFD shows a charge status of 80%, the EBB will provide at least 30 minutes operation when cold-soaked to -20°C and the display is operated at the default maximum backlight intensity. Battery operation below this temperature is not assured. The EBB charge status must be verified prior to each flight where the EBB is required by the KOEL in section 2.12.7. The minimum dispatch limit is 80% when the EBB is required.

At cold temperatures it takes 10 minutes for the EFD1000 system to calculate an accurate EBB charge status. On the ground when the battery is colder than 0°C, a timer will run for 10 minutes before EBB charge status is displayed. In the air, the charge status will be indicated after a 15 second delay. When the battery is cold (<0°C) the % remaining value will initially decrease rapidly for several minutes, but will subsequently increase and stabilize at the correct value. This stabilization process may take as long as 10 minutes. During this period the pilot should consider the charge status determined during the pre-flight checks to be the battery charge state.

NOTE: The limitations in this section apply only to those installations with an EBB installed without standby airspeed and altitude instruments. See section 2.12.7 for the Kinds of Operation Equipment List.

2.9 Geographic Limitation

Limitation: Use of the EFD1000 for IFR operations in the region within 750 nautical miles of the magnetic North or South Pole, based solely upon the altitude and heading data provided by the EFD1000, is NOT AUTHORIZED.

The ADAHRS solution in the EFD1000 uses multiple inputs, including the earth's magnetic field, to determine aircraft heading, pitch and roll. The system must be able to periodically sense the earth's magnetic vector to be able to correctly resolve heading and stabilize the ADAHRS attitude solution.

All magnetic sensors, including the one in the EFD1000, will experience degraded performance in the vicinity of the earth's magnetic poles. When the horizontal component of the earth's magnetic field is no longer strong enough to provide reliable heading data, the EFD1000 will detect this condition and compensate for the reduced magnetic fields. The system can continue to operate for a short time without

reference to magnetic North, but must be able to periodically resolve the magnetic vector to continue operations.

If the EFD1000 is unable to resolve the earth's magnetic field for two minutes, the system will switch to and annunciate Free Gyro Mode. In this mode, the ADAHRS continues to provide attitude and heading data based on gyro-only operating logic. This will be accompanied by a "FREE GYRO MODE" message posted on the HSI, and a "CROSS CHECK ATTITUDE" annunciation posted on the attitude indicator. Under these circumstances, increased vigilance and instrument cross check is required.

If the weak magnetic conditions persist, and the EFD1000 is unable to resolve the magnetic vector for six minutes or greater, then the attitude and heading solution will be considered failed and will be removed (i.e. Red X'd). The ADAHRS solution will automatically restore once the magnetic vector can again be resolved.

Within a region approximately 750 nautical miles from the magnetic pole, the conditions described above are expected to be persistent. In the Northern Hemisphere, this distance approximately equates to operations in the Arctic Islands found north of continental North America.

2.10 Placards and Decals

When the EBB has been installed and independently-powered airspeed and altitude instruments have been removed, the following placard must be shown on the instrument panel in plain view of the flight crew:

EMER BAT DISPATCH LIMIT 80%
SEE EFD AFMS

The following electronic placard is displayed during initialization of the MFD:

CAUTION:
Terrain Information for Awareness Only. Do not Maneuver Based Solely on this Information.

The aircraft ownship position presented on Instrument Procedure Charts and Airport Diagrams may be inaccurate - reference to ownship position for navigation or maneuvering is prohibited.

2.11 Seaplane Operation

Limitation: If the ADAHRS is unable to align due to wave action, departure under IMC or IFR is PROHIBITED.

The EFD1000s may not be able to align when on water as a function of the wave action being experienced by the aircraft. When aligning on water, always perform a visual verification of the attitude reference with a secondary source, such as a mechanical gyro or the horizon. If the alignment is not successful, it is acceptable to depart under VFR/VMC and, while maintaining VFR/VMC, perform an ADAHRS in-flight alignment per Section 3.5.

2.12 Hazard Awareness Limitations (EFD1000 PFD PRO and MFDs ONLY)**2.12.1 Terrain and Obstacle Display Limitation (MFD):**

Limitation: Maneuvering based solely on the EFD1000 terrain and obstacle display is NOT AUTHORIZED. Pilot in command has the responsibility to see and avoid terrain and other obstacles.
--

The EFD1000/500 MFD display of terrain and obstacle information is advisory only. In addition, the system does not provide terrain or obstacle alerts. Not all obstacles within a given region will be charted. The pilot is responsible for terrain and obstacle avoidance by visual means, or by following approved instrument procedures. At system start up the pilot must acknowledge this operational limitation by pressing either knob.

2.12.2 Traffic Display Limitation:

Limitation: Maneuvering based solely on the EFD1000 traffic display is NOT AUTHORIZED. Pilot in command has the responsibility to see and avoid traffic.

The EFD1000/500 MFD and EFD1000 PFD will display traffic information when connected to a TIS or TAS system. Traffic information is presented to assist the pilot in visually identifying nearby aircraft.

2.12.3 XM Datalink Information Limitation:

Limitation: Datalink information (e.g. NEXRAD, METAR, TFR, etc.) shown on the PFD or MFD displays is supplemental to data available from official sources.

The EFD1000/500 MFD and EFD1000 PFD may be connected to an optional EWR50 XM weather receiver. Datalink information displayed on the EFD1000 system is supplemental to the out of the cockpit view and weather information from approved sources.

The XM service and reporting area includes the United States, Southern Canada and Puerto Rico.

The maximum wind speed capable of being shown is 180 knots. Wind speeds greater than 180 knots will be shown as 180 knots.

2.12.4 Electronic Map Display Limitation:

Limitation: The EFD1000/500 moving map display is not a substitute for approved maps or charts required by the operating rules.

The EFD1000 Moving Map Display is not a substitute for approved aeronautical maps or charts from approved sources. Approved maps and charts must be carried in the aircraft, as required by the applicable operating regulations.

2.12.5 Aerodrome Moving Map Display (AMMD) Limitation:

Limitation: The aircraft ownship position presented on the Airport Diagrams may be inaccurate – reference to ownship position for navigation or maneuvering is prohibited.

The intended function of Aerodrome Moving Map Display (AMMD) is to help flight crew orient themselves on the airport surface and improve pilot positional awareness during taxi operations. AMMD function is not sufficient to be used as the basis for maneuvering and shall not be used for navigation.

This EFB AMMD with an aircraft ownship position symbol is designed to assist flight crews in orienting themselves on the airport surface to improve pilot positional awareness during taxi operations. The AMMD function is not to be used as the basis for ground maneuvering. This application is limited to ground operations only.

This function is a Class 3 Electronic Flight Bag Type C application. See FAA AC 91-78 for more information.

The intersection of the wings and fuselage of the aircraft ownship symbol on the AMMD corresponds to the ownship's actual position.

2.12.6 Terminal Procedures Charts ("Charts"), no Ownship Depiction Limitation

Limitation: Except as provided for by regulation, the Terminal Procedures Charts depictions on the EFD are not substitutes for aeronautical charts required to be carried aboard the aircraft. This function does not replace any system or equipment required by the regulations.

The intended function of the Terminal Procedures Charts depiction without the aircraft ownship depicted on the chart is to provide a convenient location to view portions of the Terminal Procedures Charts information.

The Terminal Procedures Charts depiction is not sufficient to be used as the basis for maneuvering and must not be used for navigation.

This function is a Class 3 Electronic Flight Bag Type B application. For most 14 CFR Part 91 operations, the in-flight use of an Electronic Flight Bag/Electronic Chart Display in lieu of paper reference material is the decision of the aircraft operator and the pilot in command. For Part 91 subpart K, Part 91 subpart F and Part 135, Part 121 and Part 125 operations, consult your Operating Specifications. See FAA AC 91-78 for more information.

2.12.7 Terminal Procedures Charts ("Charts") with Ownship Depiction Limitation

Limitation: The aircraft ownship position presented on the Terminal Procedures Charts may be inaccurately portrayed due to errors in the charts – reference to the ownship position for navigation or maneuvering is prohibited.

Limitation: Except as provided for by regulation, the Terminal Procedures Charts depictions on the EFD are not substitutes for aeronautical charts required to be carried aboard the aircraft. This function does not replace any system or equipment required by the regulations.

The intended function of the display of terminal procedures with the ownship position is to provide a graphical depiction of the approach chart used to improve the flight crew awareness of the aircraft ownship position relative to other items depicted on the chart.

The Terminal Procedures Charts depiction is not sufficient to be used as the basis for maneuvering and must not be used for navigation.

2.13 Kinds of Operations Equipment List (KOEL)

The EFD1000/500 system must be installed and maintained in accordance with the STC. The system is approved for day/night IFR and VFR operations in accordance with 14 CFR Parts 91. The system is generally suitable for Part 135 operations, but must be evaluated in accordance with the regulations and the limitations of the Part 135 certificate.

Table 4 below shows the minimum equipment required for dispatch based on the kind of flight operation being conducted. Any other system limitations, such as the minimum battery charge detailed within this AFMS, must also be adhered to when that equipment is required for the kinds of flight operation being conducted.

The minimum equipment required for dispatch, based on the kind of flight operation conducted, must include all of the components shown in at least one of the columns in Table 4. If all of the equipment in a particular column is installed and serviceable, then the type of operation indicated at the top of that column is authorized.

Additionally, VFR day/night operations are authorized with any of the minimum IFR equipment configurations.

For example, in a single PFD installation, if the PFD is inoperative, but a whiskey compass, altimeter and airspeed indicator are available, then the flight may proceed if conducted under day/night VFR.

NOTE: The numbers in the table refers to the quantity of items required.

Kinds of Operations Equipment Requirements (see 14 CFR Part 91.213(d))	Day VFR	Day/ Night VFR	Day/ Night VFR	IFR	IFR	IFR
EFD1000 PFD	1	1		1	1	1
EFD1000 MFD with EBB		1		1		
EFD1000 MFD with Internal Battery					1	
Magnetic Compass	1	1	1	1	1	1
Standby Attitude Indicator				1	1	1
Standby Airspeed Indicator			1		1	1
Standby Altimeter			1		1	1
IFR Approved GPS				1	1	
Analog Converter Unit	As needed for navigation. Deactivated and placarded if inoperative and not required					

Table 4 - Kinds of Operations Equipment List Pertaining to the EFD 1000 systems.

3 Emergency and Abnormal Procedures/Conditions

3.1 Pitot/Static System Blockage

If a blocked pitot or static line is suspected or annunciated, proceed as follows:

PITOT HEAT	ON
ALTERNATE STATIC SOURCE	SELECT OPEN
ATTITUDE	Maintain straight and level flight by reference to standby sources of attitude.
Consider exiting IMC	

CAUTION:

Most light aircraft have only a single pitot and static pneumatic system available for flight instrument use. Should these lines become blocked, both the standby indicators and the EFD1000 (PFD and MFD) indicators will display erroneous airspeed and altitude information.

The EFD1000 (PFD and MFD) also uses pitot and static pressures as part of the attitude and heading solution. Loss or corruption of this data will affect the accuracy or availability of attitude and heading information.

If an erroneous pitot input is detected by the EFD1000 (PFD or MFD) in flight, the EFD1000 will present red "X"s over the attitude and heading indicators, and display an amber "CHECK PITOT HEAT" annunciation

3.2 CROSS CHECK ATTITUDE Message

Persistent or frequent CROSS CHECK ATTITUDE annunciations during normal maneuvers are indicative of a degraded ADAHRS solution.

ATTITUDE	Maintain by reference to other instruments or the visible horizon
Consider exiting IMC	

NOTE:

The CROSS CHECK ATTITUDE message indicates that the statistical confidence in the ADAHRS solution is degraded. Momentary annunciations may be seen during aggressive maneuvers, such as 60 deg turns or aerobatics, which are normal.

3.3 ADAHRS Attitude Disagreement

Should differences be observed between one or more EFD1000 displays and/or the standby instruments, monitor all available attitude, airspeed, and altitude information to diagnose faulty indicator(s).

ATTITUDE	Maintain straight and level flight
If an EFD1000 ADAHRS is suspected as faulty, proceed as follows:	
AUTOPILOT	DISCONNECT
MENU	Select "GENERAL SETTINGS" Page
"ADAHRS: RESET?" LINE SELECT KEY	PRESS
"ADAHRS: RESET?" LINE SELECT KEY	PRESS AGAIN TO CONFIRM RESET
Consider exiting IMC	

CAUTION:

The EFD1000 PFD and MFD may share a common pitot/static system and their otherwise independent attitude solution may be similarly affected by pitot/static faults.

3.4 MFD Reversionary Mode Operation (EFD1000 MFD only)

To select REV mode, proceed as follows:

EFD1000 MFD REV Button	MOMENTARY PRESS
REVERSIONARY PFD Display	Configure as desired
BARO SETTING	Verify

NOTE:

Pressing and holding the REV key for 5 seconds will shut off the unit. The REV button is located on the EFD bezel, marked with "REV" in red text.

NOTE:

When reversion mode is selected, verify that the display is configured as necessary. Items to consider include Baro Setting, Altitude Bug, Airspeed Bug, Minimums, CDI Nav Source, Selected Course and Heading, ARC/360 Mode, Map configuration, Weather, Traffic and Lightning overlays, etc.

In the unlikely event of a failure of the PFD, including the loss of ADC or ADAHRS functions, the EFD1000 MFD can revert to PFD operation. With a single press and release of the red text REV key located on the MFD bezel the MFD will immediately change to the PFD operating mode. To return to the MFD operating mode, press the REV key again. In the MFD Reversionary PFD mode, operation is identical to the PFD except the optional tone generator will no longer function. In addition, selection of the REV mode does not switch autopilot outputs to the MFD. Rather, autopilot outputs remain connected to the EFD1000 PFD. If the PFD is failed, autopilot operation may be unavailable or limited.

Information that is not related to Primary Flight Information (e.g. navigation configuration data such as navigation source, selected course, selected heading, altitude bug, minimums bug, airspeed bug) is not passed between the displays, and, therefore, must be configured or verified by the pilot, as necessary, prior to entering critical phases of flight. After configuring the MFD REV mode, the unit may be returned to normal MFD operation. This simple step will ensure that the MFD is ready to assume all of the duties performed by the PFD should that equipment experience a failure.

3.5 In-Flight ADAHRS Reset

To reset an EFD1000 ADAHRS proceed as follows:

ATTITUDE	MAINTAIN STRAIGHT AND LEVEL FLIGHT by visual reference, or by standby instruments
AUTOPILOT	DISCONNECT
MENU	Select "GENERAL SETTINGS" Page A
"ADAHRS: RESET?" LINE SELECT KEY	PRESS
"ADAHRS: RESET?" LINE SELECT KEY	PRESS AGAIN TO CONFIRM ADAHRS RESET
	Activate any other control to cancel the reset

NOTE:

When an EFD1000 ADAHRS is manually reset in flight, it performs an abbreviated initialization that usually takes less than 30 seconds. During the initialization, the attitude and direction information are removed and replaced with red "X"s and the annunciations, "ATTITUDE FAIL" and "DIRECTION INDICATOR FAIL" are presented. Gentle maneuvering during the initialization is permitted. The ADAHRS reset is considered complete when the EFD1000 attitude and heading are once again displayed and the attitude display is stable and correct with respect to other sources of attitude information.

The EFD1000 ADAHRS is normally stable, self-correcting, and accurate. The pilot may elect to manually reset it if pitch and roll indications disagree with the standby attitude indicator, or the ADAHRS is suspected to be inaccurate (e.g., following aerobatic maneuvers). The ADAHRS reset function is analogous to "caging" a gyroscopic attitude indicator.

3.6 Alternator or Generator Failure, or ON BAT Annunciation

UNRESTORABLE LOSS OF EXTERNAL POWER IS AN EMERGENCY SITUATION

Electrical System	Follow AFM procedures to restore power
<u>If unable to restore aircraft alternator or generator</u>	
EFD1000/500 Circuit Breaker / Switch	OPEN for each display
LAND AS SOON AS POSSIBLE	

CAUTION:

If the aircraft alternator or generator fails and the EFD is operated until its battery is exhausted, the screen may fade to solid white for several seconds before blanking. To avoid this condition at night, manually turn off the EFD once the display shows 0% battery remaining.

NOTE:

The internal battery normally provides 30-60 minutes of operation at 20°C and warmer. At very cold temperatures internal battery operation is not assured.

The Emergency Backup Battery will provide at least 30 minutes of operation with 80% indicated charge when at -20°C. A fully charged EBB at +20°C or warmer will typically provide power for two or more hours of operation.

When operating "ON BAT" the maximum "auto" backlight setting is 40% and the maximum manual backlight setting is 70%. Changing the backlight setting changes battery endurance, reflected by the % remaining indication.

A fully charged battery will indicate a charge level of 99% for some time before beginning to show discharge. Once discharge is indicated the charge level will decrease in a steady manner with a slight acceleration nearing 0%.

The "ON BAT" annunciation and estimated charge remaining, is displayed in the upper half of each EFD whenever the system is operating from battery.



The internal battery (or EBB) provides power for both the EFD and optional RSM GPS.

If aircraft generated power to the EFD is degraded or fails, such as from an aircraft alternator or generator failure, each EFD will begin an automatic load-shed routine, and will disconnect from the power bus two minutes after input power degrades, or immediately if the input power fails.

To complete the load-shed process, the pilot must open each EFD Circuit Breaker / Switch. This may be done as soon as the degraded power is noticed.

These actions prevent the EFD from automatically restarting from connected external power should the flight continue until the EFD battery is fully depleted. If it is desired to reconnect the EFD to the aircraft

power bus, close the associated Circuit Breaker / Switch and select EXT Power from the Power Settings Menu.

3.7 Abnormal Shutdown Procedure

In the event of an EFD malfunction requiring in-flight shut down of the equipment, proceed as follows

EFD1000 MFD (with EBB)
 EFD Circuit Breaker / Switch OFF / PULL
 EBB Disconnect Switch DISC

- OR -

EFD1000/500 display with internal battery
 EFD Circuit Breaker / Switch OFF / PULL
 REV Button PUSH AND HOLD UNTIL
 DISPLAY BLANKS

NOTE:

Heading and navigation inputs to the autopilot are provided by the PFD. Turning off the PFD may affect selected or available autopilot modes.

NOTE:

Each EFD 1000/500 has a labeled circuit breaker and optional master switch or a combined circuit breaker / switch. These switches are mounted on or adjacent to the instrument panel and within the pilot's reach.

3.8 EBB Disconnect (EFD1000 MFD only)

To isolate the EBB in the event of an EBB or EFD1000 MFD malfunction, proceed as follows:

EBB Switch Select DISC

NOTE:

When in the "DISC" position, the EBB isolation relay is powered from the EBB. When the switch is in the disconnect position the Emergency Backup Battery will gradually discharge.

The EBB is protected by thermal and short-circuit sensing circuitry to prevent battery overheating or damage. The battery is normally connected to its EFD1000 MFD. If it is desired to remove battery power from the EFD1000 MFD, or to otherwise isolate the EBB, the EBB includes an externally activated

isolation relay integral to the EBB aluminum housing. This relay is activated by the EBB Disconnect switch installed in the instrument panel.

The EBB Emergency Disconnect switch is either a guarded or lever-lock switch mounted on or adjacent to the instrument panel and within the pilot's reach. The switch should be left in the NORM position at all times, including when away from the aircraft. When it is desired to disconnect the EBB from the EFD1000 MFD display, move the switch to the DISC position.

3.9 Power Override

In the event that the pilot wishes to override the automatic power configuration of the equipment, proceed as follows:

MENU	"POWER SETTINGS"
	Page
<u>To switch FROM aircraft power to Battery:</u>	
"BATTERY" LINE SELECT KEY	PRESS
<u>To switch FROM Battery TO aircraft power:</u>	
"EXT PWR" LINE SELECT KEY.....	PRESS

3.10 EFD1000/500 Intercommunications Failure

In the event of a "CROSS LINK FAILURE" message, verify that barometric altimeter setting information is correctly transferred between the displays. On the EFD1000 MFD, the barometric altimeter setting can only be set from the MFD REV mode.

BARO SETTING	VERIFY
If EFD1000 Baro Setting must be set	
EFD1000 MFD REV Button	PRESS TO DISPLAY PFD
BARO SETTING	SET

CAUTION:

<p>Relative terrain is based on the barometric altitude from the EFD1000 displays. BARO setting may not be shared between the EFD1000 displays during this Cross Link Failure condition. It is necessary to set BARO individually on both EFD1000 displays to prevent the display of erroneous relative terrain.</p> <p>The Barometric Pressure Setting is shown on the EFD1000/500 MFD data bar.</p>

An intercommunications link exists between the EFD1000 PFD, EFD1000 MFD, and EFD500 MFD to share various information, including barometric setting, heading, airspeed and altitude information. The EFD1000 PFD and EFD1000 MFD both receive and transmit data to each other, and each also transmits data to the EFD500 MFD. The EFD500 MFD only receives data, but does so from each installed EFD1000 display.

In the event of an intercommunication failure between the EFD1000 PFD, EFD1000 MFD, or EFD500 MFD, a CROSS LINK FAILURE annunciation will be presented in the affected PFD/MFD's data bar.

When this occurs, the altimeter's barometric pressure setting may not be communicated between EFDs. It will be necessary to confirm if the baro setting information is being transferred. If it is not, the pilot should manually adjust the BARO setting on the affected display. For the EFD1000 MFD, this is accomplished in the PFD Reversion Mode.

In a three display configuration it is possible for the EFD500 MFD to display this message, but still maintain synchronization. This indicates that only one of the intercommunications buses to the EFD500 has failed.

3.11 Loss of GPS information

CAUTION:

In the event of complete GPS failure, the Nav Map stops moving and orients North Up, the airplane symbol is removed and reverts to a stationary map with an accompanying "GPS POS FAILED" annunciation. In this case, the Nav Map may be manually panned to correlate to the estimated aircraft position determined by other means.

Position and flight plan data for the PFD and MFD is provided from aircraft GPS equipment. The EFD displays may be configured to receive data from one or two external GPS systems. In addition, when an RSM connected to the EFD includes an emergency GPS, this information may be used if the aircraft GPS system(s) fail.

The Nav Map function in either the PFD or MFD follows an automatic position reversion scheme to determine which GPS is the position source for the map. The primary GPS is always the one selected by the pilot, either by the associated CDI nav source (PFD), or via the menus (MFD). If the selected GPS fails, the EFD automatically switches to another GPS (when installed), and will annunciate "GPS# Reversion", where # represents the GPS source providing position data.

If all external GPS systems fail, and an RSM GPS is connected to that display, the EFD will use position data from the RSM and annunciate RSM GPS REVERSION EMER USE ONLY." In this case, the map data is approved for emergency use only.

Whenever the map has reverted to an alternate position source, all map features and capabilities are retained, including the display of the flight plan from the selected GPS. However, when the GPS position source is different from the source that generated the flight plan, the flight plan is presented without showing an active (magenta) leg. The flight plan and map data from each external GPS is retained independently. If two external GPS were connected prior to, and if each had a different flight plan at the time of failure, both of these flight plans are retained and can be viewed by the pilot.

In the unlikely event that there is a complete loss of all GPS data to an MFD, including loss of the RSM GPS (if installed), the NAV Map is retained, the flight plan is removed, and the map is no longer updated with aircraft position information. An annunciation of "GPS POS FAILED" is presented in the center of the map, the airplane symbol is removed, the map changes to a North-up orientation and the map will no longer move with the aircraft. Manual panning is still possible and all map features that are not GPS position dependent continue to remain available, including relative terrain overlays.



3.12 MFD Database Card

Each EFD1000 MFD and EFD500 MFD includes a microSDHC (SD card, High Capacity) card slot into which a database card with terrain and Nav Map data may be inserted. The database card must remain in the EFD display as data is dynamically loaded from the microSDHC into the EFD memory during flight as the aircraft position changes.

In the event that the microSDHC database card is removed from the card slot, or communications with the card fails, the MFD will continue to operate using the last data that was loaded into memory. As the aircraft position changes, the software will attempt to access the data card to retrieve additional data for the new location. When this occurs, if the data card cannot be detected, an annunciation of "DATABASE FAILURE" is displayed at the bottom of the Nav Map. When this occurs the previously loaded data remains available, but new data information (such as roads, rivers, nav aids, and detailed terrain data that has not yet been loaded into memory) will not be available to add to the navigation map.

When the data card is restored, restarting the EFD will reinitialize the database.

3.13 Warning, Caution, and Advisory Summary









Warning







Caution







Advisory













	Applicability					Annunciation	Description
	EFD 1000 PFD PRO	EFD 1000 PFD PLOT	EFD 1000 MFD REV	EFD 1000 MFD	EFD 500 MFD		
W	✓	✓	✓	✓	✓		<p>Red annunciations presented whenever the EFD1000 is operating on the internal or EBB. The countdown timer appears first, and is then replaced by the ON BAT and % charge annunciation</p>
W	✓	✓	✓	✓			<p>Red annunciation presented whenever the EFD1000 determines that the associated function is invalid or failed.</p> <p>On the EFD1000 MFD SAI and SHSI, only the "ATTITUDE FAIL" and "DIRECTION INDICATOR FAIL" annunciations are presented.</p> <p>These indications are also presented when the ADAHRS system is re-initializing after a manual or automatic reset.</p> <p>Fly by reference to standby sources of attitude, altitude and airspeed, such as the EFD1000 MFD, standby instruments, or the visible horizon.</p> <p>In this circumstance GPSS operation is still possible. In addition, the LDI and VDI will continue to remain available and display either GPS approach lateral and vertical deviations, or localizer lateral deviation information, which may be manually flown.</p>
W	✓	✓	✓	✓			<p>Red chevrons displayed on the Attitude Indicator's pitch scale to indicate extreme pitch up and down attitudes and the appropriate fly-to direction to restore level flight.</p>











	Applicability					Annunciation	Description
	EFD 1000 PFD PRO	EFD 1000 PFD PLOT	EFD 1000 MFD REV	EFD 1000 MFD	EFD 500 MFD		
C	✓	✓	✓	✓		CROSS CHECK ATTITUDE	Amber annunciation centered in the upper half of the attitude indicator whenever the EFD1000 ADAHRS internal integrity monitor determines that attitude is potentially degraded. If a steady CROSS CHECK ATTITUDE annunciation is presented, cross check attitude, airspeed and altitude indications against alternate sources.
C				✓		ADAHRS FAIL	Amber annunciation displayed in the data bar of the EFD1000 MFD when its internal ADAHRS reports a failure (e.g. during ADAHRS Reset)
C				✓		CHECK AHRS	Amber annunciation presented on the EFD1000 MFD when its internal ADAHRS reports a "CROSS CHECK ATTITUDE" condition.
C				✓	✓	CROSS LINK FAILURE	Amber annunciation presented in the EFD1000 MFD Data Bar when it loses communication with the PFD, and in the EFD500 MFD data bar when it loses communication with either the PFD or the EFD1000 MFD.
				✓	✓	(HDG FAIL)	Amber annunciation presented on the MFD in the Charts, Nav Map and WX applications when heading has failed.
C	✓	✓	✓	✓		[REDACTED]	Amber annunciation accompanied by an "ATTITUDE FAIL" annunciation. Presented when the software detects an obstruction in the pitot system that could potentially degrade the attitude solution. This annunciation is removed when the detected condition is resolved, which would be followed by an automatic ADAHRS reset. A GPS system is required for this monitor to be enabled.







	Applicability					Annunciation	Description
	EFD 1000 PFD PRO	EFD 1000 PFD PLOT	EFD 1000 MFD REV	EFD 1000 MFD	EFD 500 MFD		
C	✓	✓*	✓	✓	✓	    	<p>Amber annunciations presented when a connected GPS is invalid or not available. GPS# or RSM REVERSION (optional) annunciations indicate the current GPS basemap source. Note: the EFD500 MFD cannot revert to RSM GPS since it is not configured with an RSM.</p> <p>*GPS2 is not applicable to the PFD Pilot. "GPS1", "RSM GPS" and "RSM GPS REVERSION" are the only annunciations of this type that apply to the PFD Pilot.</p>
C				✓	✓		<p>Amber annunciation presented in the center of the NAV Map when all GPS sources have failed. When presented, the map changes to a North-up orientation and the map no longer moves with the aircraft. Manual panning is still possible and all map features that are not GPS position dependent continue to remain available, including relative terrain overlays.</p>
C	✓	✓	✓	✓			<p>Amber annunciation presented whenever the selected GPS source indicates that GPS integrity is degraded. See the applicable GPS AFMS for more information.</p>
C	✓		✓				<p>Amber annunciation presented when the aircraft reaches, or is below the set MINIMUMS. Will be accompanied by a one-second stuttered tone when the optional tone generator is installed. Not applicable to the PFD Pilot.</p>
C	✓	✓*	✓				<p>Amber flag presented to indicate the aircraft is reaching (steady) or deviating (flashing) the selected altitude. Will be accompanied by a one-second steady tone when the optional tone generator is installed.</p> <p>*The tone is not available on the PFD Pilot.</p>

	Applicability					Annunciation	Description
	EFD 1000 PFD PRO	EFD 100 0 PFD PLOT	EFD 100 0 MF D REV	EFD 100 0 MF D	EFD 500 MF D		
C	✓		✓				Amber "DH" annunciation presented when a connected radar altimeter indicates the aircraft has reached the radar altitude set by the pilot. See the radar altimeter's AFMS for more information. Not applicable to the PFD Pilot.
C	✓		✓			 GPSS	GPSS annunciation that indicates the previously selected GPSS source is invalid (e.g. the flight plan was deleted) or a different GPSS has been selected by pilot. Commands the autopilot to roll the aircraft to wings level until GPSS is re-engaged, or a valid GPSS signal is available. Not applicable to the PFD Pilot.
C				✓	✓		Amber annunciation presented on the dedicated terrain display when any of the information needed to render the map (position, altitude, or heading) is detected as invalid.
C				✓	✓		A "TRAFFIC" Advisory annunciation is presented in the data bar whenever a connected traffic system generates a Traffic Advisory and a dedicated traffic view is not being displayed.
							TRFC* legend above the lower center button is presented to inform the pilot of the single pilot action needed show a dedicated traffic display.
C	✓		✓	✓	✓		Amber annunciations provided when Traffic data is reported as unavailable by the connected traffic sensor. Not applicable to the PFD Pilot.
C				✓	✓		Amber annunciation that indicates that the traffic data has not been refreshed within 6 seconds. The Primary Flight Display shows only TRFC RMVD.

	Applicability					Annunciation	Description
	EFD 1000 PFD PRO	EFD 100 0 PFD P/L OT	EFD 100 0 MF D REV	EFD 100 0 MF D	EFD 500 MF D		
C				✓	✓		Amber annunciation that indicates a traffic sensor failure.
C				✓	✓		Amber annunciation on the dedicated traffic display to indicate that the link between the EFD and traffic sensor has been lost (e.g., traffic sensor is OFF).
C				✓	✓		Amber annunciation presented when the spherics (lightning) sensor reports that the self-test response has not been received within 10 seconds of the test request.
C				✓	✓	FAIL	Amber annunciation presented when the spherics (lightning) sensor reports a failed self-test, an unrecoverable fault, or an undefined fault.
C				✓	✓	ERROR	Amber annunciation presented when the spherics (lightning) sensor reports an undefined but recoverable error
C				✓	✓		Amber annunciation presented when the spherics (lightning) sensor reports a recoverable antenna error
C				✓	✓		Amber annunciation presented when the spherics (lightning) sensor reports a recoverable inhibit line stuck microphone error
C				✓	✓		Amber annunciation presented when the spherics (lightning) sensor reports a recoverable changed antenna jumper error.
C				✓	✓		Amber annunciation presented when the spherics (lightning) sensor reports no heading data. Accompanied by removal of spherics (lightning) sensor data.

	Applicability					Annunciation	Description
	EFD 1000 PFD PRO	EFD 1000 PFD PLOT	EFD 1000 MFD REV	EFD 1000 MFD	EFD 500 MFD		
C				✓	✓		Amber annunciation presented when the spherics (lightning) sensor reports that the sensor is enabled but no data is detected
C	✓		✓	✓	✓	     	Datalink weather product data not received. Not applicable to the PFD Pilot.
C	✓	✓	✓				Annunciation presented on the PFD HSI whenever the HSI compass card is no longer receiving magnetic corrections. After 6 minutes of free gyro operation the attitude and heading solutions will be removed.
C	✓	✓	✓	✓	✓		Annunciation presented in the menus when the connected EFD1000 battery is not detected or failed
A	✓	✓			✓		Annunciation presented when the EFD1000 PFD's or EFD500 MFD's "REV" button is pressed.
A			✓	✓			Annunciation presented when the EFD1000 MFD's "REV" button is pressed.
A	✓		✓			 	Green annunciations provided whenever GPSS is enabled and the GPS source is valid. Either "GPSS1" or "GPSS2" may be annunciated depending on aircraft configuration. Not applicable to the PFD Pilot.

	Applicability					Annunciation	Description
	EFD 1000 PFD PRO	EFD 100 0 PFD PIL OT	EFD 100 0 MF D REV	EFD 100 0 MF D	EFD 500 MF D		
A	✓		✓	✓			GPS annunciations provided by an active GPS source. TERM may also be displayed in the same location as APPR. See the GPS AFMS for additional information on the meaning of these annunciations.
A	✓		✓	✓	✓		Green annunciation that indicates that the traffic sensor is enabled. Not applicable to the PFD Pilot.
A				✓	✓		Green annunciation that indicates that the traffic sensor is in standby.
A				✓	✓		Green annunciation that indicates that the traffic sensor is in the self-test mode.
A				✓	✓		Green annunciation that indicates that the TIS traffic data has not been refreshed within 6 seconds.
A	✓		✓	✓	✓		Lightning (spherics) Strike display mode selected. The rate indicates the approximate number of lightning strikes detected per minute. Not applicable to the PFD Pilot.
A	✓		✓	✓	✓		Lightning (spherics) Cell clustering display mode selected. The rate indicates the approximate number of lightning strikes detected per minute. Not applicable to the PFD Pilot.
A	✓		✓	✓	✓		Self-test mode annunciation that replaces spherics (lightning) Strike / Cell rate information. Not applicable to the PFD Pilot.
A				✓	✓		Lightning (spherics) Self-test mode selected.
A				✓	✓		Annunciation that replaces aircraft ownership symbol during a spherics (lightning) self-test.

	Applicability					Annunciation	Description
	EFD 1000 PFD PRO	EFD 100 PFD PLOT	EFD 100 MF D REV	EFD 100 MF D	EFD 500 MF D		
A	✓		✓	✓	✓		A data age annunciation is presented for datalink weather products when the XM receiver is operational. The elapsed time since last data update is expressed in minutes (e.g.05). Not applicable to the PFD Pilot.
A	✓		✓	✓	✓		A horizontal red line through the spherics (lightning) rate legend that indicates the data is no longer detected. Not applicable to the PFD Pilot.
A	✓		✓	✓	✓		A horizontal red line through the legend of selected data indicates that the data is invalid, unavailable, or for datalink products, that the data product is expired. Not applicable to the PFD Pilot.
A	✓		✓				A horizontal red line through the source legend of selected data indicates that the data is invalid or unavailable. Not applicable to the PFD Pilot.
A	✓		✓	✓			A horizontal red line through the selected navigation source indicates that the data is invalid or unavailable. HSI and SHSI only. Not applicable to the PFD Pilot.
A				✓	✓		Annunciation presented at the bottom center of the Nav Map or the Charts application if the software is unable to access the data base stored to the microSDHC memory card.
A				✓	✓		Annunciation presented at the bottom center of the Nav Map when data is being loaded from the micro SD card at start up. The current data type and total number of data types to be loaded is identified (i.e. "11/1"), along with an indication of the type of data that is currently being loaded (i.e. "AIRWAYS").

	Applicability					Annunciation	Description
	EFD 1000 PFD PRO	EFD 100 0 PFD P/L OT	EFD 100 0 MF D REV	EFD 100 0 MF D	EFD 500 MF D		
A				✓	✓	OWNSHIP NOT AVAILABLE	Annunciation presented at the top center of the CHARTS application when the OWN hotkey is selected and the aircraft ownship cannot be displayed because the chart is not geo-referenced.
A				✓	✓	OWNSHIP OFF CHART	Annunciation presented at the top center of the CHARTS application when the displayed chart is geo-referenced, the OWN hotkey is selected and the aircraft position is not on the chart.

4 Normal Procedures

4.1 Exterior Inspection

RSM(s).....	Check condition and security
RSM Vent Hole.....	Check clear of obstructions
RSM Lightning Tape.....	Check condition and security



4.2 Before Taxi Checks

Alternate Static Source.....	CHECK
EBB Switch (if installed).....	Verify set to NORM
EFD MASTER SWITCHES (if installed).....	ON
Avionics and Instruments.....	SET as desired
PFD.....	Configure for departure
EFD1000 MFD (if installed).....	Select REV and configure as necessary

CAUTION:

The EFD1000 MFD Reversionary PFD display references, bugs, navigation sources, etc. must be configured or verified as necessary for takeoff and departure. This will reduce pilot workload should the MFD reversion mode be required.

NOTE:

ADAHRS alignment begins at power up. Avoid movement during ADAHRS alignment as this will delay and degrade the ADAHRS initialization. Attitude and heading data is presented once alignment is complete.

NOTE:

When in the "DISC" position, the EBB isolation relay is powered from the EBB. When the switch is in the disconnect position the Emergency Backup Battery will gradually discharge.

NOTE:

MFD database features load incrementally after power up. Loading progress is indicated at the bottom of the Nav Map.

4.3 Before Take-Off Checks

MENU	"POWER SETTINGS" Page
EXT PWR: (Aircraft Input Voltage)	Check > 12.3V/24.6V
BAT:	Verify battery status is not shown as "FAIL" (normally this shows "CHARGING" or "READY")
In addition, if an EFD1000 MFD with EBB is installed, perform the following steps from the Power Settings Page:	
EFD1000 MFD	Select "BATTERY"
EFD1000 MFD	Verify Battery charge is above 80%
EFD1000 MFD	Select EXT PWR
MENU	Press the MENU button to return to normal operation

CAUTION:

If an EFD is required by the Kinds Of Operations Equipment List, takeoff with indicated aircraft voltage (as displayed in the EFD Power Settings Menu) below 12.3V (14 Volt aircraft) or 24.6V (28Volt aircraft) is NOT AUTHORIZED

If the indicated aircraft voltage is below 12.3V (14V Electrical System) or 24.6V (28V Electrical System) the EFD will automatically switch to battery shortly after takeoff.

Indicated aircraft voltages below these thresholds are indicative of an aircraft electrical system charging problem that must be resolved before flight.

CAUTION:

If the EBB is required by the Kinds Of Operations Equipment List (See section 2.12.7), the minimum EBB charge permitted for dispatch is 80%

CAUTION:

If the EBB temperature is below -20°C the battery may not power the EFD1000 until warmed. When an EBB is required by the kinds of operations limitations (See section 2.12.7), the cabin temperature must be above -20°C before departure

NOTE:

If the EBB temperature is below 0°C, it will take 10 minutes or longer to determine the "BATTERY" charge. Indicated battery charge may rise from the initial indication as the battery warms.

The internal or EBB battery will not charge until the battery temperature is above 0°C. The battery will have to be allowed to warm to accept a charge.

4.4 Before Approach Checks

EBB Switch (if installed).....	Verify set to NORM
Avionics and Instruments	SET as desired
PFD.....	Configure for arrival
EFD1000 MFD (if installed)	Select REV and configure as necessary

CAUTION:

The EFD1000 MFD Reversionary PFD display references, bugs, navigation sources, etc. must be configured or verified as necessary for landing and missed or final approach. This will reduce pilot workload should the MFD reversion mode be required.

4.5 Shutdown Checks

EFD1000/EFD500 Circuit Breaker / Switches.....	OFF
EBB Switch (if installed).....	Verify set to NORM

NOTE:

The EBB disconnect switch should be left in the NORM position, except during an abnormal condition. When in the "DISC" position the EBB energizes a relay that is powered from the EBB. When the switch is in the DISC position the EBB will gradually discharge.

NOTE:

Each EFD display includes either an internal battery or external EBB. On the ground the EFD will initiate a shut down sequence when aircraft power is removed. If this sequence is interrupted, the EFD will continue to operate from battery until the battery is depleted.

To avoid inadvertently discharging the EFD battery, confirm that each EFD is completely powered down before leaving the aircraft.

5 Performance

No change to basic Airplane Flight Manual or other performance information or placards.

6 Weight & Center of Gravity

See current weight and balance records.

7 EFD1000/500 System Operation

Refer to Aspen Avionics document 091-00005-001, EFD1000 PFD Pilot's Guide and Aspen Avionics document 091-00006-001, EFD1000/500 MFD Pilot's Guide, for detailed operating instructions of the EFD1000 PFD, EFD1000 MFD, and EFD500 MFD systems.

NOTE:

Although intuitive to operate, a reasonable degree of familiarity is required to effectively use the EFD1000/500 system.

Study this AFMS, the Pilot's Guides, and seek instruction from a competent instructor to gain and maintain familiarity and competence with this system.

Gain experience with the system under VMC before flying in IMC.

Practice often.

Go Fly!

ASPEN AVIONICS
A NEW WAY TO LOOK AT AVIONICS

8 List of Acronyms and Abbreviations

A/P	Autopilot
ACU	Analog Converter Unit
ADAHRS	Air Data Attitude Heading Reference System
AFMS	Airplane Flight Manual Supplement
AMMD	Aerodrome Moving Map Display
BARO	Barometric Pressure Setting
BAT	Battery
CM	Configuration Module
DH	Decision Height
EBB	Emergency Backup Battery
EFB	Electronic Flight Bag
EFD	Evolution Flight Display
EFIS	Electronic Flight Instrument System
EOC	Executable Object Code
EWR	Evolution Weather Receiver
GPS	Global Positioning System
GPSS	GPS Steering
HDG	Heading
HSI	Horizontal Situation Indicator
IAS	Indicated Airspeed
IFR	Instrument Flight Rules
IMC	Instrument Meteorological Conditions
IOP	Input-Output Processor
KOEL	Kinds of Operations Equipment List
MAP	Main Application Processor
MEMS	Micro Electromechanical Systems
MFD	Multi-Function Display
NACO	National Aeronautical Charting Office
OAT	Outside Air Temperature
PFD	Primary Flight Display
REV	Reversion
RMVD	Removed
RSM	Remote Sensor Module
SAI	Secondary Attitude Indicator
SDHC	Secure Digital, High-Capacity
SHSI	Secondary Horizontal Situation Indicator
TAS	True Airspeed
TAS	Traffic Advisory System
TIS	Traffic Information System
TRFC	Traffic
VFR	Visual Flight Rules
VMC	Visual Meteorological Conditions
VOR	VHF Omni-directional Radio Range
VLOC	VOR / Localizer

AJ Wheeler Investments Pty Ltd
Bowral NSW

ESM-Cessna310-34-001

APPROVED FLIGHT MANUAL SUPPLEMENT

CESSNA 310R

FITTED WITH

**GARMIN GNS530AW VHF COMMUNICATIONS
TRANSCEIVER, VOR/ILS RECEIVER, AND GPS
RECEIVER**

DOCUMENT NO: ESM-Cessna310-34-001

Reg. No. VH-WME

Serial No. 310R0712

This document must be carried in the aircraft at all times when the aircraft is modified by installation of the Garmin GNS530AW GPS/NAV/COM/WAAS SYSTEM in accordance with Garmin Installation Manual 190-00357-02 Rev B (or later issue) and Engineering Solutions Engineering Order ESE-Cessna310-34-001.

The information contained herein supplements or supersedes the Basic Flight Manual only in those areas listed herein. For Limitations, Procedures, and Performance information not contained in this supplement consult the basic Airplane Flight Manual.

AJ Wheeler Investments Pty Ltd
Bowral NSW

GARMIN GNS530AW

ESM-Cessna310-34-001

LOG OF PAGES

<u>Issue</u>	<u>Date</u>	<u>Page</u>	<u>Description</u>
1	07/06/2010	1-27	Original issue

This document is approved per CAR 35(2)		
Authorised Person	ARN	IOA
Brett Conrad	439936	AEB 08/029
Signature:		Date:
		08/06/10

APPROVED: B. Conrad Date: 08/06/10

Authorised Person per CAR (1988) 35

ENGINEERING SOLUTIONS

Prepared by: B. Conrad

Checked by: D. Bowden

GARMIN GPS/NAV/COM GNS 530AW

GENERAL DESCRIPTION

Engineering Order ESE-Cessna310-34-001 installs a Garmin GNS 530AW GPS/NAV/COM in the airplane.

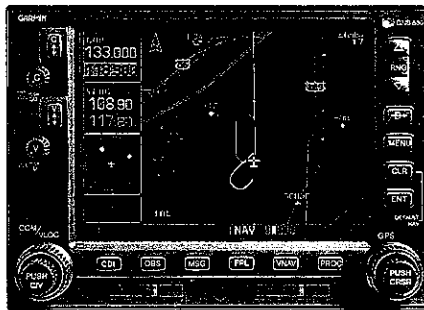

SECTION I: GENERAL

The GNS 530AW System is a fully integrated, panel mounted instrument, which contains a VHF Communications Transceiver, a VOR/ILS receiver, and a Global Positioning System (GPS) Navigation computer. The system comprises a GPS antenna, GPS Receiver, VHF VOR/LOC/GS antenna, VOR/ILS receiver, VHF

COMM antenna and a VHF Communications Transceiver. The primary function of the VHF Communication portion of the equipment is to facilitate communication with Air Traffic Control. The primary function of the VOR/ILS Receiver portion of the equipment is to receive and demodulate VOR, Localizer, and Glide Slope signals. The primary function of the GPS portion of the system is to acquire signals from the GPS system satellites, recover orbital data, make range and Doppler measurements, and process this information in real-time to obtain the user's position, velocity, and time.

The Garmin GNS530AW GPS display is a 3.8" diagonal 128 by 240 pixel colour LCD. The unit includes two removable data cards, one with a Jeppesen Navigation database (to be inserted into the leftmost card slot), and the second being a Terrain database (to be inserted into the rightmost card slot).

GPS TSO-C146a (RTCA/DO-229C Class 3): The Garmin GNS530AW GPS system complies with FAA AC 20-138A for IFR navigation using GPS for en route, terminal area, and non-precision approach operations (including "GPS", or "GPS and RNAV" approaches).

The GNS530AW has the ability to make use of the Wide Area Augmentation System (WAAS) or other Space-Based Augmentation System (SBAS) complying with ICAO Annex 10 within the system coverage and service volume for enroute, terminal area, non-precision approach operations (including "GPS", or "GPS and RNAV" approaches), and approach procedures with vertical guidance (including "LNAV/VNAV" and "LPV").

When operating within North America, WAAS provides augmentation information to GPS receivers to enhance the accuracy and reliability of position estimates.

The signals from GPS satellites are received across the National Airspace System (NAS) at many widely-spaced Wide Area Reference Stations (WRS) sites. The WRS locations are precisely surveyed so that any errors in the received GPS signals can be detected.

The GPS information collected by the WRS sites is forwarded to the WAAS Master Station (WMS) via a terrestrial communications network. At the WMS, the WAAS augmentation messages are generated. These messages contain information that allows GPS receivers to remove errors in the GPS signal, allowing for a significant increase in location accuracy and reliability.

The augmentation messages are sent from the WMS to uplink stations to be transmitted to navigation payloads on geostationary communications satellites.

The navigation payloads broadcast the augmentation messages on a GPS-like signal. The GPS/WAAS receiver processes the WAAS augmentation message as part of estimating position. The GPS-like signal from the navigation transponder can also be used by the receiver as an additional source for calculation of the user's position.

The system as described is for the US based WAAS; a list of other SBAS systems that are in operation or under development are listed below, these form a part of the global network.

Satellite Based Augmentation Systems:

EGNOS

European Geostationary Navigation Overlay Service

WAAS

Continental United States Wide Area Augmentation System

MSAS

Japanese MTSAT Satellite Augmentation System

NOTE:

The satellite service currently being received in Australia is MSAS but since Australia lies outside the service volume the corrections are not being used by the GPS receiver. Refer to Limitations section 2.6 for further details.

The GNS530AW is:-

- Approved IFR enroute, terminal, Non-Precision GPS Approach, oceanic and remote continental region operations when operated in accordance with the Civil Aviation Safety Authority (CASA) Civil Aviation Safety Regulations (CASR).
- Navigation is accomplished using the WGS-84 coordinate reference datum. Navigation is based upon use of only the Global Positioning System (GPS) operated by the United States of America.

- Pressure altitude is automatically provided from an approved source. Therefore, these systems may be used as a Primary Means IFR Navigation for enroute and terminal operations including GPS Arrivals, GPS/DME Arrivals, and approved Supplemental Non-Precision Approaches as published in the AIP.

SECTION 2: LIMITATIONS

2.1 GARMIN Pilot's Guide & Reference

The Garmin GNS530AW Series Pilots Guide & Reference, P/N 190-00140-00, Rev. N (Aug 2008) (or later appropriate revision) must be immediately available to the flight crew whenever navigation is predicated on the use of the system.

2.2 Software Versions

The GNS530AW must utilise the following or later FAA approved software versions:

Sub – System	Software Version
Main	3.00
GPS	3.00
COMM	7.00
VOR / LOC	5.01
G/S	4.00

The GNS530AW must utilize the following or later FAA approved software versions:

Function	Sub-System Version				
	Main	GPS	COM	VOR/LOC	G/S
Initial Approval	2.00	2.00	2.00	1.25	2.00
Traffic / Weather Interface	2.08	2.00	2.00	1.25	2.00
Primary Oceanic/Remote	3.00	3.00	2.00	1.25	2.00

The Main software version is displayed on the GNS530AW self test page immediately after turn-on for 5 seconds. The remaining software versions can be verified on the AUX group sub-page 2, "SOFTWARE/DATABASE VER".

NOTE:

Subsequent software versions may support different functions. Check the 500W series Pilot's Guide document No 190-00140-00 Rev. N (Aug 2008) or later for further information.

2.3 Database Revisions

A valid and compatible database must be installed and contain current NavData as per following table:

Part Number	Rev.	Description
010-10546-00	B or later	Data card, WAAS, IFR, World Wide
010-10546-01	B or later	Data card, WAAS, IFR, Americas
010-10546-02	B or later	Data card, WAAS, IFR, International

The GNS530AW supports Terrain and requires a Terrain database card to be installed in order for the feature to operate. The table below lists compatible database cards for the GNS530AW series. Each of the data base cards contains the following data:

Part Number	Rev.	Description
010-10201-20	C or later	Data card, TAWS/Terrain, 128MB
010-10546-01	A or later	Data card, TAWS/Terrain, 256MB

2.4 IFR with correct Database or Waypoints

IFR en route and terminal navigation predicated upon the GNS530AW's GPS Receiver is prohibited unless the pilot verifies the currency of the data base or verifies each selected waypoint for accuracy by reference to current approved data.

2.5 Other Approved NAV Equipment Required

The aircraft must have other approved navigation equipment installed and operating appropriate to the route of flight.

2.6 GPS Equipment Database to be I.A.W Approved Procedures

Instrument approach navigation predicated upon the GNS530AW's GPS Receiver must be accomplished in accordance with approved instrument approach procedures that are retrieved from the GPS equipment data base. The GPS equipment data base must incorporate the current update cycle.

2.7 RAIM availability in the GPS Final Approach Fix

Instrument approaches utilizing the GPS receiver must be conducted in the approach mode and Receiver Autonomous Integrity Monitoring (RAIM) must be available at the Final Approach Fix.

2.8 GNS530AW and the AIP

The GNS530AW GPS must be used in accordance with the applicable Aeronautical Information Publication (AIP):

- (a) Supplemental means en-route IFR navigation aid.
- (b) Primary means en-route and area IFR/NVFR navigation aid.
- (c) Non-precision approach IFR navigation aid.
- (d) GPS in lieu of DME

2.9. VOR/ILS Receiver Usage

Use of the GNS530AW VOR/ILS receiver to fly approaches not approved for GPS require VOR/ILS navigation data to be present on the EHSI.

2.10. No IFR when the EHSI is found inoperative pre flight

IFR approaches are prohibited, if the EHSI is found to be inoperative during pre-flight. (This limitation does not prohibit conducting an IFR approach, if the EHSI fails during flight. The indications provided on the GNS530AW unit display may be used as a backup).

2.11 Alternate airport not supported by GPS

When an alternate airport is required by the applicable operating rules, and served by an approach based on *other* than GPS navigation, the aircraft must have the operational equipment capable of using that navigation aid, and the required navigation aid must be operational.

2.12 VNAV for advisory only

VNAV information may be utilized for advisory information only. Use of VNAV information for Instrument Approach Procedures does not guarantee Step-Down Fix altitude protection, or arrival at approach minimums in normal position to land.

2.13 Default Settings in SETUP Menu

If not previously defined, the following default settings must be made in the "SETUP 1" menu of the GNS530AW prior to operation (refer to Pilot's Guide for procedure if necessary):

1. **dis, spd** nm kt (sets navigation units to "nautical miles" and "knots")
2. **alt, vs** ft fpm (sets altitude units to "feet" and "feet per minute")
3. **map datum** WGS 84 (sets map datum to WGS-84, see note below)
4. **posn** deg-min (sets navigation grid units to decimal minutes)

NOTE:

In some areas outside the United States, datum's other than WGS-84 may be used. If the GNS530AW is authorised for use by the appropriate airworthiness authority, the required geodetic datum must be set in the GNS530AW prior to use for navigation.

2.14 Terrain

Terrain refers to the display of terrain information. The terrain display is intended to serve as a situational awareness tool only and does not provide TAWS capability. It does not provide either the accuracy or fidelity, or both, on which to solely base decisions and plan manoeuvres to avoid terrain or obstacles. TERRAIN unit alerts

are advisory only and are not equivalent to warnings provided by a TAWS unit.

- (a) GNS530AW must utilize Main Software 3.00 or later FAA approved software version.
- (b) Navigation must not be predicted upon use of the TERRAIN display.
- (c) To avoid giving unwanted alerts, TERRAIN should be inhibited when landing at an airport that is not included in the airport database.
- (d) Pilots are not permitted to deviate from their current ATC clearance to comply with terrain/obstacle alerts from a TERRAIN unit except as allowed for in the AIP.
- (e) The TERRAIN databases have an area of coverage as detailed below:
 - (i) The TERRAIN Database has an area of coverage from North 75° Latitude to South 60° Latitude in all longitudes.
 - (ii) The Airport Terrain Database has an area of coverage that includes the USA, Canada, Mexico, Latin America and South America.
 - (iii) The Obstacle Database has an area of coverage that includes the USA.

NOTE:

TERRAIN warnings are advisory only and are not equivalent to warnings provided by a TAWS unit.

The area of coverage may be modified as additional terrain data sources become available.

2.15 Automatic Switching GPS / ILS

The automatic switching between GPS and ILS is to be disabled for NPA operations. To disable this function, the following setting must be made in the "SET UP 1" menu of the GNS530AW prior to operation (refer to Pilot's Guide for procedure if necessary).

- (a) Select **CDI/Alarms** and press **ENT** key.
- (b) Change **ILS CDI SELECTION** to **Manual**.

The capacity for automatic switching between GPS and ILS guidance is now disabled and the pilot must now select the desired guidance source.

2.16 SBAS functions in Australia

Australia is currently outside a SBAS service volume so the GNS530AW will not process SBAS (WAAS) signals; however Australia is within coverage of SBAS satellites. The SBAS satellites provide two functions: one is the SBAS augmentation data, the other is a GEO ranging signal. The GEO ranging signal provides functions like other GPS satellites - this in turn provides the

system with improved satellite availability, therefore this function should be enabled.

To enable this function the following setting must be made in the "SET UP 2" menu of the GNS530AW prior to operation (refer to Pilot's Guide for procedure if necessary).

- (a) Select **SBAS selection** and press **ENT** key
- (b) Change **WAAS enabled to ON** (using small right knob) and press **ENT** key
- (c) Press **small right knob** to exit

2.17 GPS CDI Scaling

The GNS530AW WAAS receiver, whether the SBAS function is enabled or disabled, calculates the approach as angular scaling down to $\pm 350\text{ft}$ (equivalent to 0.1 nm) at the runway threshold, rather than linear scaling of 0.3 nm from the FAF as used in a GARMIN GNS530AW a non WAAS unit.

The differences are as shown below.

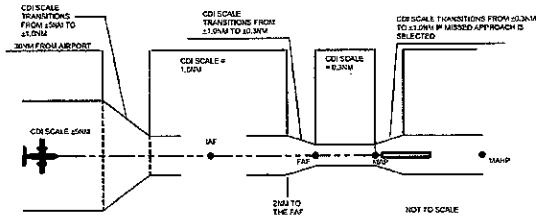

NON WAAS GPS APPROACH CDI SCALE.

1. WITHIN 30NM OF THE DESTINATION AIRPORT THE GPS WILL SWITCH FROM "ENROUTE" MODE TO "TERMINAL" MODE. THE SCALE TRANSITION IS FROM 40NM TO 10.0NM, FULL SCALE DEFLECTION.
2. WITHIN 7.5NM FROM THE JAF THE SCALE WILL SWITCH FROM "TERMINAL" TO "APPROACH" MODE. SCALE TRANSITION FROM 10.0NM TO 0.3NM.
3. WHEN ENROUTE AN MISSED APPROACH AT THE MAP THE SCALE WILL TRANSITION FROM 0.3NM TO 10.0NM TERMINAL MODE TO THE MAP.

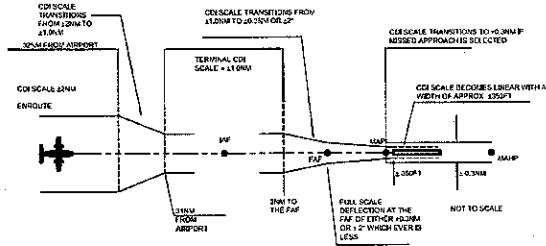

WAAS GPS APPROACH CDI SCALE.

1. THE CDI SCALE TRANSITION FROM 22.0NM "ENROUTE MODE", TO 2.0 NM "TERMINAL MODE" SCALE WITHIN 37NM FROM THE DESTINATION AIRPORT. ONCE WITHIN 45° OF THE FINAL APPROACH COURSE AND THE FAF IS THE TO WAYPOINT, THE 40W UNIT SWITCHES FROM TERMINAL MODE TO APPROACH MODE. CDI SCALING IS TIGHTENED FROM 11.0NM FULL SCALE DEFLECTION TO EITHER 10.0NM OR 12° FULL SCALE DEFLECTION WHICHEVER IS LESS AT THE FAF. THE SCALING CHANGE OCCURS GRADUALLY OVER A 2.0M DISTANCE PRIOR TO REACHING THE FAF. AT THE LANDING THRESHOLD POINT (LTP) THE ANGULAR SCALE THEN OCCOMES LINEAR AGAIN WITH A WIDTH OF APPROXIMATELY 1.00FT.
2. MISSED APPROACH PROCEDURES REFER TO SECTION 1 OF THE PILOTS GUIDE FOR OPERATIONAL DETAILS. IF SBAS IS ANNUNCIATED THE CDI SCALING WILL CHANGE TO 25.0NM FULL SCALE DEFLECTION OR IF TERRIS ANNUNCIATED THE SCALING WILL CHANGE TO 1.0 NM.

3. FLIGHT PHASE	AUTO CDI SCALING
DEPARTURE	16.0NM
OCEANIC	22.0NM
ENROUTE	25.0NM
TERMINAL MODE	11.0NM
APPROACH (NON-PRECISION)	11.0NM DECREASING TO 1.00NM (DEPENDS ON VARIABLES)
APPROACH (LNAV/VNAV)	11.0NM DECREASING TO 1.00NM (DEPENDS ON VARIABLES)
APPROACH (LPV)	11.0NM DECREASING TO 1.00NM (DEPENDS ON VARIABLES)
MISSED APPROACH	10.0NM

2.18 EPU (Estimated Position Uncertainty)

A measure of satellite geometry quality and additional factors, is expressed as a horizontal position error, estimated by the Fault Detection and Exclusion (FDE) algorithm (in feet, metres or NM). This information can be viewed on the Satellite Status page along with Horizontal Figure of Merit (HFOM), Vertical Figure of Merit (VFOM).

HFOM and VFOM represent 95% confidence levels in horizontal and vertical accuracy. The lower the number the better the accuracy, the higher the number the poorer the accuracy.

CAUTION:

When SBAS is turned on, with the aircraft operating outside a SBAS service volume, high EPU errors may be displayed. If this is the case, before conducting an

approach, ensure that HFOM and VFOM are observed to be low numbers.

2.19 Satellite Availability & Accuracy

Users are cautioned that satellite availability and accuracy may be subject to change.

2.20 Garmin Prediction for RAIM Availability

Garmin Prediction Program P/No 006-A0154-03 (with installed antenna GA35 selected) should be used to confirm the availability of RAIM for the intended flight.

Terrain Display

Terrain refers to the display of terrain information. Pilots are NOT authorized to deviate from their current ATC clearance to comply with terrain/obstacle alerts. Terrain unit alerts are advisory only and are not equivalent to warnings provided by TAWS. Navigation must not be predicated upon the use of the terrain display.

The terrain display is intended to serve as a situational awareness tool only. By itself, it may not provide either the accuracy or the fidelity on which to base decisions and plan maneuvers to avoid terrain or obstacles. It may not provide either the accuracy, fidelity, or both, on which to solely base decisions and plan maneuvers to avoid terrain or obstacles.

The use of the terrain avoidance warning and terrain display functions is prohibited during QFE (atmospheric pressure at airport elevation) operations.

2.20 Weather Detection Display

The GNS530AW is interface to the WX500 Stormscope. Weather detection is presented on the GNS530AW display. Refer to the Garmin Pilot's Guide Addendum Part Number 190-00356-31 for a description of the WX500 weather information on the GNS530AW display.

SECTION 3: EMERGENCY PROCEDURES

3.1 In Flight Emergency

In an in-flight emergency, depressing and holding the GNS530AW Comm transfer button for 2 seconds will select the emergency frequency of 121.500 MHz into the "Active" frequency window.

3.2 GNS530AW GPS Loss of Power

Circuit protection is provided by "Trip-Free" design circuit breakers located in the pilot's circuit breaker panel. The system circuit breakers are identified as 'NAV/GPS 2' and 'No. 2 COM'.

3.3 GNS530AW GPS Loss of Integrity Monitoring (RAIM)

3.3.1 If a "RAIM NOT AVAILABLE" message is displayed:

While conducting an instrument approach:

Terminate the approach.

Execute a missed approach if required.

3.3.2 If "RAIM IS NOT AVAILABLE" message is displayed:

In the en route, terminal, or initial approach phase of flight:

Continue to navigate using the GPS equipment or revert to an alternate means of navigation other than the GNS530AW's GPS receiver appropriate to the route and phase of flight.

When continuing to navigate using GPS navigation, position must be verified every 10 minutes using the GNS530AW's VOR/ILS receiver or another IFR-approved navigation system.

3.3.3 If "RAIM IS NOT AVAILABLE" message is displayed

In the final approach segment:

GPS based navigation will continue for up to 5 minutes with the approach CDI sensitivity (0.3 nautical miles).

After 5 minutes the system will flag and no longer provide course guidance with approach sensitivity. Missed approach

course guidance may still be available with 1 nautical mile CDI sensitivity by executing the missed approach.

3.3.4 If "RAIM POSITION WARNING" message is displayed:

The system will flag and no longer provide GPS based navigational guidance.

The crew should revert to the GNS530AW VOR/ILS receiver or an alternate means of navigation other than the GNS530AW's GPS receiver.

3.4 GNS530AW GPS Annunciator Messages

Refer to the GNS530AW Pilot's Guide 190-00140-00 Rev. N (Aug 2008) or later revision, for appropriate pilot actions to be accomplished in response to annunciated messages.

SECTION 4: NORMAL PROCEDURES

4.1 Pilot Training

Prior to operational use of the GNS530AW - GPS in this aircraft, the operating crew must be appropriately endorsed in accordance with the current operating rules.

4.2 GNS530AW Pilot's Guide

Normal operating procedures are outlined in the Garmin GNS530AW Pilot's Guide and Reference P/N 190-00140-00 Rev. N (Aug 2008) (or later revision).

4.3 Pilot/Co-Pilot VHF Communication

COM selection is provided by the pilot's/co-pilot's audio panel. When COM 2 is selected then communication information is controlled by the channel selection of the GNS530AW COM.

4.4 Pilot's Display

The GNS530AW System data appears on the pilot's EHSI. The source of the data is selectable between either GPS 2 or VLOC 2 and this can be achieved, either by selection of the GPS 2 or VLOC 2 on the EHSI or on the GNS530AW.

4.5 Instrument Panel Annunciation

4.5.1 External GPS 2 and VLOC 2 annunciation

The EHSI provides external GPS 2 annunciation and selection between GPS 2 and VLOC 2.

4.5.2 GNS530AW Annunciations

The annunciation operates in unison with the internal annunciation provided by GNS530AW as follows:

4.5.3 MSG (Message)

To alert the pilot of any important information or warnings. While most messages are advisory in nature, warning messages may require pilot intervention. When the 'MSG' annunciator flashes, press the MSG Key located on the GNS530AW front to display the message. Press the MSG Key again to return to the previous page.

4.5.4 WPT (Waypoint)

- (a) When the aircraft is within 10 seconds of reaching the turning point for a course change, the waypoint annunciator flashes.
- (b) When the aircraft is in a turn, the waypoint annunciator illuminates and remains illuminated until the turn is completed.
- (c) When a user arrival alarm is set and the aircraft is within the circle defined by the arrival alarm radius at the arrival waypoint, the waypoint annunciator flashes for 10 seconds.
- (d) When a user arrival alarm is not set and the aircraft is within 10 seconds of reaching the arrival waypoint, the waypoint annunciator flashes.

4.5.5 APR (Approach)

When performing a GPS approach, the approach annunciator will illuminate once the approach becomes active.

4.6 OBS Selection

Remote OBS Mode Selection with its corresponding annunciation is used to toggle between GPS OBS and GPS AUTO modes of operation. This performs the same function as pressing the 'OBS' key located on the GNS530AW front panel. The OBS Key is used to select manual (OBS mode) or automatic sequencing of

waypoints. Activating OBS mode holds the current active **To** waypoint as the navigation reference and prevents the GPS from sequencing to the next waypoint. When OBS mode is cancelled, automatic waypoint sequencing is reselected, and the GNS530AW automatically selects the next waypoint in the flight plan once the aircraft has crossed the present active-to waypoint.

4.8 Pilot's EFD 1000 EHSI & STEC 55X Autopilot Operation

The GNS530AW System data will appear as GPS 2 or VLOC 2 on the pilot's EHSI.

The source of data being selectable between either GPS 2 or VLOC 2 as annunciated on the EHSI and on the GNS530AW display located above the CDI key. Coupling of the GNS530AW System steering information to the autopilot is accomplished by engaging the autopilot in the NAV 2 or APR mode.

When the autopilot system is using course information supplied by the GNS530AW, the course pointer will not be automatically slewed to the desired track and the course pointer on the EHSI must be manually set to the desired track (DTK) as indicated by the GNS530AW. For detailed autopilot operational instructions, refer to the FAA Approved STEC 55X Flight Manual Supplement No 891837 and the pilots operating handbook "Fifty Five X" for the autopilot operation.

4.9 Automatic Localizer Course Capture

As a default, the GNS530AW automatic localizer course capture feature is enabled. This feature provides a method for system navigation data displayed on the pilots EHSI being switched automatically from GPS guidance to localizer / glide slope guidance at the point of course intercept on a localizer at which GPS derived course deviation equals localizer derived course deviation. If an offset from the final approach course is being flown, it is possible that the automatic switch from GPS course guidance to localizer / glide slope course guidance will not occur. It is the pilot's responsibility to ensure correct system navigation data is presented on the EHSI before continuing a localizer based approach beyond the final approach fix.

4.10 Approach / RAIM Prediction

The information contained in this section is vital for successful operation of the GNS530AW during approach mode. The following is a summary of the approach navigation features provided by the GNS530AW.

- (a) The pilot may, at any time, select an approach, either ILS or GPS, which is available for the destination airport (see Pilot's guide for more information on selecting approaches). The destination airport is defined to be the last waypoint in the active route or the current direct – to airport.

Follow the procedure outlined in the Pilot's Guide to obtain the predicted RAIM for the waypoint selected.

TERRAIN AWARENESS CAUTION

When a terrain awareness CAUTION occurs take positive corrective action until the alert ceases. Stop descending or initiate either a climb or a turn, or both, as necessary, based on analysis of all available instruments and information.

TERRAIN AWARENESS WARNING

If a terrain awareness WARNING occurs, immediately initiate and continue a climb that will provide maximum terrain clearance, or any similar approved vertical terrain escape maneuver, until all alerts cease. Only vertical maneuvers are recommended, unless either operating in visual meteorological conditions (VMC), or the pilot determines, based on all available information, that turning in addition to the vertical escape maneuver is the safest course of action, or both.

SECTION 5: PERFORMANCE

No Change.

SECTION 6: WEIGHT AND BALANCE

Refer to current weight and balance data.

FAA APPROVED

AIRPLANE FLIGHT MANUAL SUPPLEMENT
or
SUPPLEMENTAL AIRPLANE FLIGHT MANUAL
for
GARMIN GMX 200 SYSTEM INSTALLATION
as installed in

CFSSNA 310R
Make and Model Airplane

Reg. No. VH-LME S/N 310R0712
VH-JTV

This document serves as an Airplane Flight Manual Supplement or as a Supplemental Airplane Flight Manual when the aircraft is equipped with the Garmin GMX 200 unit. This document must be carried in the airplane at all times when the Garmin GMX 200 is installed in accordance with STC# SA01692SE.

The information contained herein supplements or supersedes the information made available to the operator by the manufacturer in the form of clearly stated placards, markings, or manuals or in the form of an FAA approved Airplane Flight Manual, only in those areas listed herein. For limitations, procedures and performance information not contained in this document, consult the basic placards, markings, or manuals or the basic FAA approved Airplane Flight Manual.

FAA APPROVED

Manager, Aircraft Certification Office
Federal Aviation Administration
Seattle, Washington

DATE: 13 July 2007

AFMS for GMX 200 Multi-Function Display
190-00607-01 Rev. B
Page 1 of 8

FAA APPROVED

DATE: JUL 13 2007

Table of Contents

SECTION	PAGE
Section 1. GENERAL	4
1.1 Garmin GMX 200 MFD	4
Section 2. LIMITATIONS	5
2.1 Operation	5
2.2 Pilot's Guide	5
2.3 System Software	5
2.4 Magnetic Variation	5
2.5 Power on Self Test (POST)	6
2.6 ADS-B Broadcast Mode Control	6
2.7 Weather Radar Control	6
Section 3. EMERGENCY PROCEDURES	7
3.1 Emergency Procedures	7
3.2 Abnormal Procedures	7
Section 4. NORMAL PROCEDURES	7
Section 5. PERFORMANCE	8
Section 6. WEIGHT AND BALANCE	8
Section 7. SYSTEM DESCRIPTIONS	8

Section 1. GENERAL

1.1 Garmin GMX 200 MFD

The GMX 200 Multi-Function Display (MFD) is a General Aviation in-cockpit display designed to provide the pilot with a wide variety of situational awareness related information. The display is capable of displaying Traffic, Moving Map, Terrain Awareness information VFR/IFR charting functions, and FIS uplinked weather. Basic information displayed includes airports, navigational aids, terrain, current flight plan and more.

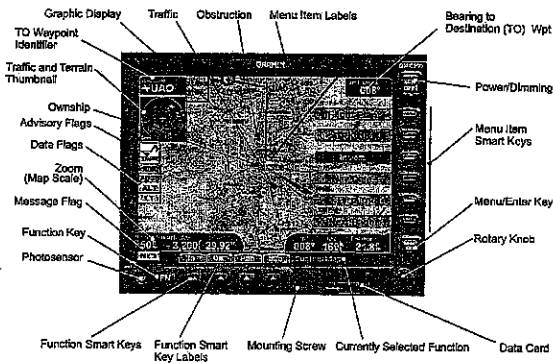

Figure 1 - GMX 200 Control and Display Layout

Section 2. LIMITATIONS

2.1 Operation

GMX 200 moving map display use is limited to situational awareness. The GMX 200 integrates with separately approved navigation sensor installations.

If the GMX 200 has no heading information, when winds aloft are significant, the traffic presentation may be offset by any wind correction angle.

Adherence to limitations in AFM supplements for interfaced systems is mandatory.

2.2 Pilot's Guide

The GARMIN GMX 200 Pilot's Guide, part number and revision listed below (or later FAA approved revision), must be immediately available for the flight crew.

- Pilot's Guide P/N 190-00607-02 Rev. A.

2.3 System Software:

The system must utilize a software version listed below (or later FAA approved versions). The software version can be displayed in the system mode on the GMX 200 display under the INFO smart key. Software versions support different functions; check the GMX 200 Pilot's Guide for more information.

Table 1 - Approved Software Versions

Software Item	Approved Software Version (or later FAA approved versions)	
	SW version	As displayed on unit
Airborne SW	2.12	2.12

2.4 Magnetic Variation

The automatic magnetic variation (MagVar) correction is not available in the GMX 200 above 73° North or below 73° South latitude. All bearing and track information is computed and displayed relative to true north in these polar regions.

2.5 Power on Self Test (POST)

The GMX 200 performs a self test when power is applied. The pilot is responsible for verifying all tests pass. If any of the GMX 200 tests fail, power off the GMX 200.

2.6 ADS-B Broadcast Mode Control

If the GMX 200 is configured to control a GDL 90 UAT Datalink Sensor:

- The GDL 90 does not replace any required equipment.
- The GDL 90 UAT datalink is approved for Air Traffic Control (ATC) ADS-B Surveillance Services in the United States. For areas where ATC Surveillance Services are provided, the UAT equipment shall broadcast aircraft position, velocity, barometric altitude information, flight identification and/or a 4096 squawk code.
- When directed by ATC to turn "off" the ADS-B transmission, pilots should use the GMX 200 ADS-B broadcast mode control function to stop ADS-B transmissions while airborne or on the surface. (Press FN, then TRAF, then MENU, then "Next Page" as necessary to display "Tx Alt" or "Tx Alt Off" on the top button label. Press the top button until "Standby" is displayed.)

UAT datalink is also used to receive Traffic Information Services-Broadcast (TIS-B) and Flight Information Services-Broadcast (FIS-B) information.

Not all areas of the United States have the capability to provide ATC services or TIS-B/FIS-B information on the UAT datalink. Refer to Notice to Airman for areas of coverage and operational applications, found on the FAA website: www.flyadsb.com.

2.7 Weather Radar Control

RADAR is broadcasting energy when a green "RDR" flag (solid or flashing) is displayed on the GMX 200. If the GMX 200 is configured to control an airborne weather radar unit, observe all safety precautions including:

- Do not operate in the vicinity of refueling operations.
- Do not operate while personnel are in the vicinity (approximately 20 feet) of the radar sweep area.

WARNING

If a radar system is installed, it generates microwave radiation and improper use, or exposure, may cause serious bodily injury. DO NOT OPERATE THE RADAR EQUIPMENT UNTIL YOU HAVE READ AND CAREFULLY FOLLOWED THE SAFETY PRECAUTIONS AND INSTRUCTIONS in the RADAR USER MANUAL

2.7.1 Electronic Flight Bag Functions

The GMX200 has been evaluated as an Electronic Flight Bag device (EFB) as a Class 3 Type B device limited to the display of following types of electronic charts: area, approach and airport surface maps. No other functions displayed on the GMX200 are approved for use as an EFB. Additional approvals may be required to utilize the GMX200 EFB chart functions, see AC 120-76A for applicability.

Section 3. EMERGENCY PROCEDURES

3.1 Emergency Procedures

No change.

3.2 Abnormal Procedures

No change.

Section 4. NORMAL PROCEDURES

The normal operating procedures for the GMX 200 are described in the Pilot's Guide listed in the Section 2.1. The pilot shall review and clear all messages after power up.

CAUTION

It is recommended to view all functions in the Track-UP mode to avoid disorientation when transferring to the Traffic page.

Since the GMX 200 is limited to situational awareness, annunciations are only advisory in nature. No maneuvers are authorized by the GMX 200. The GMX 200 may display red or yellow annunciations:

- Red PULL UP or yellow TERR – The pilot should follow the guidance provided by the primary TAWS system installed.
- Yellow TRAFFIC ALERT – Visually acquire traffic and maintain proper separation.
- Yellow ADSB – The pilot should be aware that the aircraft ADS-B system is not broadcasting own ship data.
- Other yellow annunciators indicate a failure of that function – The pilot should recognize the loss of that data.

The pilot's guide contains a complete list of annunciations and their meanings.

Section 5. PERFORMANCE

No change.

Section 6. WEIGHT AND BALANCE

See current weight and balance data.

Section 7. SYSTEM DESCRIPTIONS

See Garmin GMX 200 Pilot's Guide for a complete description of the GMX 200 system.

LOAD DATA SHEET

DA 735

Organisation :			
Aircraft Type :	310R	VH- JTV	Serial No. 310R0712
Approved Loading System :	IAW 310R PILOT OPERATING HANDBOOK AND SUPPLIMENTS		

Authorised	Date	Date of Expiry	Issue
S. Whitehead	22/7/13	22/07/2016	11

Empty Aircraft Weight and Balance

Item	Weight(kg)	Arm(mm)	Index Units	Configuration
Empty Weight	1708.5	910	1554818	6 POB

Remarks

Empty : Unusable Fuel and Full Oil.

APPROVED

SIGNED

DATED 22/7/13

S. Whitehead AQ 35

POBox 789

Biggera Waters

Qld 4216

0755 715847