

06

**DIMENSIONS
AND AREAS**

LIST OF EFFECTIVE PAGES

CHAPTER	PAGE	DATE	CHAPTER	PAGE	DATE
■ 06-LEP (BA)	1	SEP 04		17	JUN 02
	2	JUN 02		18	JUN 02
06-TC (BA)	1	JUN 02		19	JUN 02
	2	JUN 02		20	JUN 02
				21	JUN 02
06-00-00 (BA)	1	JUN 02		22	JUN 02
	2	JUN 02		23	JUN 02
06-10-00 (BA)	1	JUN 02		24	JUN 02
	2	JUN 02		25	JUN 02
	3	JUN 02		26	JUN 02
	4	JUN 02		27	JUN 02
06-10-00 (BM)	1	JUN 02	■ 06-30-00 (BM)	1	SEP 04
	2	JUN 02		2	JUN 02
	3	JUN 02		3	JUN 02
	4	JUN 02		4	JUN 02
06-20-00 (BA)	1	JUN 02		5	JUN 02
	2	JUN 02		6	JUN 02
	3	SEP 04		7	JUN 02
	4	JUN 02		8	JUN 02
	5	JUN 02		9	JUN 02
	6	JUN 02		10	JUN 02
	7	JUN 02		11	JUN 02
	8	JUN 02		12	JUN 02
■ 06-30-00 (BA)	1	SEP 04		13	JUN 02
	2	JUN 02		14	JUN 02
	3	JUN 02		15	JUN 02
	4	JUN 02		16	SEP 04
	5	JUN 02		17	SEP 04
	6	JUN 02		18	SEP 04
	7	JUN 02		19	SEP 04
	8	JUN 02		20	SEP 04
	9	JUN 02		21	SEP 04
	10	JUN 02		22	SEP 04
	11	JUN 02		23	SEP 04
	12	JUN 02		24	SEP 04
	13	JUN 02		25	SEP 04
	14	JUN 02		26	SEP 04
	15	JUN 02			
	16	JUN 02			

AAAA
Validity : S / N 1 - 9999

PAGE INTENTIONALLY LEFT BLANK

TABLE OF CONTENTS

SUBJECT	CHAPTER	PAGE	VALIDITY
DIMENSIONS AND AREAS	06-00-00 (BA)	1	1 - 9999
DESCRIPTION AND OPERATION		1	
1. GENERAL		1	
DIMENSIONS AND SURFACES	06-10-00 (BA)	1	1 - 9999
DESCRIPTION AND OPERATION		1	Pre-MOD. 151
1. GENERAL		1	
A. General dimensions of the aircraft		1	
B. Wings		2	
C. Ailerons		2	
D. Wing flaps		2	
E. Horizontal stabilizer		2	
F. Vertical stabilizer		2	
G. Landing gears		3	
DIMENSIONS AND SURFACES	06-10-00 (BM)	1	1 - 9999
DESCRIPTION AND OPERATION		1	Post-MOD. 151
1. GENERAL		1	
A. General dimensions of the aircraft		1	
B. Wings		1	
C. Ailerons		1	
D. Wing flaps		1	
E. Horizontal stabilizer		1	
F. Vertical stabilizer		2	
G. Landing gears		2	
AREA LOCATIONS	06-20-00 (BA)	1	1 - 9999
DESCRIPTION AND OPERATION		1	
1. GENERAL		1	
2. DESCRIPTION		1	
A. Area 100		1	
B. Area 200		1	
C. Area 300		2	
D. Area 500		2	
E. Area 600		2	
F. Area 700		2	
INSPECTION DOORS	06-30-00 (BA)	1	1 - 9999
DESCRIPTION AND OPERATION		1	Pre-MOD. 151
1. GENERAL		1	
2. DESCRIPTION		2	
A. Area 100 - Power plant		2	

AAAA

Validity : S / N 1 - 9999

06-TC (BA)

Page 1
JUN 02

SUBJECT	CHAPTER	PAGE	VALIDITY
INSPECTION DOORS (Cont'd)	06-30-00 (BA)		
B. Area 200 - Fuselage		6	
C. Area 300 - Stabilizers		16	
D. Areas 500 / 600 - Wing		18	
E. Area 700 - Landing gear		22	
INSPECTION DOORS	06-30-00 (BM)	1	1 - 9999
DESCRIPTION AND OPERATION		1	Post-MOD.151
1. GENERAL		1	
2. DESCRIPTION		2	
A. Area 100 - Power plant		2	
B. Area 200 - Fuselage		4	
C. Area 300 - Stabilizers		14	
D. Areas 500 / 600 - Wing		16	
E. Area 700 - Landing gear		20	

**DIMENSIONS AND AREAS
DESCRIPTION AND OPERATION**

1. GENERAL

This chapter presents :

- airplane dimensions : overall length, width (span), height at fin - refer to 06-10-00,
- areas (wings, stabilizers) - refer to 06-10-00,
- airplane zoning - refer to 06-20-00,
- identification of inspection doors, access plates and panels as described in the text - refer to 06-30-00.

PAGE INTENTIONALLY LEFT BLANK

**DIMENSIONS AND SURFACES
DESCRIPTION AND OPERATION**

1. GENERAL (Figure 1)

Single engine, low cantilever wing aircraft, made entirely of metal.

A. General dimensions of the aircraft

Total length (Dimension A) 25 ft 4 in (7.72 m)

Aircraft equipped with lighting assy Option or Post-MOD. 139

Total length (Dimension A) 25 ft 5.1 in (7.75 m)

All

Height on ground (Dimension B) 9 ft 10.9 in (3.02 m)

Overall span (Dimension C) 32 ft 5.4 in (9.89 m)

Propeller (Standard) – S / N 1 – 764, 766 – 878 Pre-MOD. 72

Manufacturer SENSENICH

Type 74 DM6 S8 – 061

Propeller diameter :

- Maxi 74 in (1.88 m)

- Mini 72 in (1.83 m)

Ground clearance (Dimension D) 9.4 in (240 mm)

Propeller (Optional) – S / N 1 – 764, 766 – 878

Manufacturer HARTZELL

Type HC.C2YL-1BF/F 7663 A-4

Propeller diameter :

- Maxi 72 in (1.83 m)

- Mini 70 in (1.78 m)

Ground clearance (Dimension D) 10.4 in (265 mm)

Propeller – Post-MOD. 72, Pre-MOD. 139

Manufacturer SENSENICH

Type 74 DM6 S8 – 054

Propeller diameter :

- Maxi 74 in (1.88 m)

- Mini 72 in (1.83 m)

Ground clearance (Dimension D) 9.4 in (240 mm)

AAAA

Validity : S / N 1 – 9999 Pre-MOD. 151

06-10-00 (BA)

Page 1
JUN 02

Propeller - Post-MOD. 139

Manufacturer SENSENICH
 Type 74 DM6 S8 - 058
 Propeller diameter :
 - Maxi 74 in (1.88 m)
 - Mini 72 in (1.83 m)
 Ground clearance (Dimension D) 9.4 in (240 mm)

All

Cabin, forward external width 4 ft (1.22 m)
 Cabin, rear external width 4 ft 3.2 in (1.30 m)

B. Wings

Profile RA 16 - 3C3
 Aspect ratio 8
 Dihedral 4°
 Aerodynamic chord 4 ft (1.22 m)
 Wing area 128.09 sq.ft (11.90 m²)
 Setting + 3°

C. Ailerons

Unit area 4.90 sq.ft (0.46 m²)
 Mean span 4 ft 1 in (1.24 m)

D. Wing flaps

Unit area 10 sq.ft (0.93 m²)
 Mean span 8 ft 4.4 in (2.55 m)

E. Horizontal stabilizer

Span (Dimension E) 10 ft 6 in (3.20 m)
 Stabilator area, anti-tab included 26.73 sq.ft (2.48 m²)
 Anti-tab area 5.78 sq.ft (0.54 m²)
 Anti-tab automaticity 85 %

F. Vertical stabilizer

Fin area 9.47 sq.ft (0.88 m²)
 Rudder area 6.78 sq.ft (0.63 m²)

G. Landing gears

Telescopic leg main landing gear

Track (Dimension F) 7 ft 7.7 in (2.33 m)

Wheel base (Dimension G) 6 ft 5.2 in (1.96 m)

Trailing arm main landing gear

Track (Dimension F) 7 ft 6.5 in (2.30 m)

Wheel base (Dimension G) 6 ft 3.6 in (1.92 m)

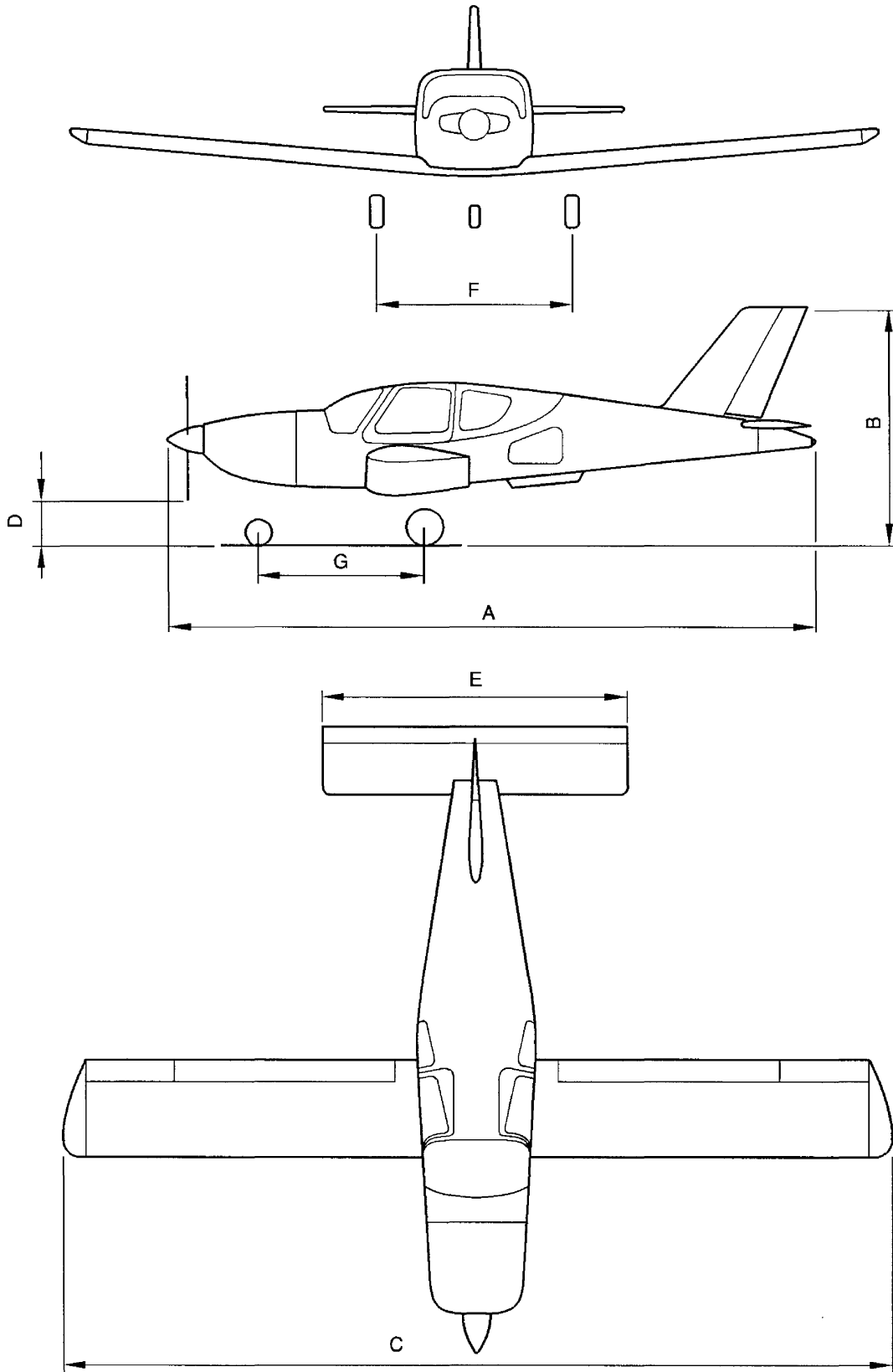

14061000AAA BVZ4001

Three-view drawing
Figure 1

**DIMENSIONS AND SURFACES
DESCRIPTION AND OPERATION**

1. GENERAL (Figure 1)

Single engine, low cantilever wing aircraft, made entirely of metal.

A. General dimensions of the aircraft

Total length (Dimension A)	25 ft 4 in (7.72 m)
Height on ground (Dimension B)	9 ft 10.9 in (3.02 m)
Overall span (Dimension C)	32 ft 11.3 in (10.04 m)
Propeller	
Manufacturer	SENSENICH
Type	74 DM6 S8 - 058
Propeller diameter :	
- Maxi	74 in (1.88 m)
- Mini	72 in (1.83 m)
Ground clearance (Dimension D)	9.4 in (240 mm)
Cabin, forward external width	4 ft (1.22 m)
Cabin, rear external width	4 ft 3.2 in (1.30 m)

B. Wings

Profile	RA 16 - 3C3
Aspect ratio	8
Dihedral	4°5
Aerodynamic chord	4 ft (1.22 m)
Wing area	128.09 sq.ft (11.90 m ²)
Setting	+ 3°

C. Ailerons

Unit area	4.90 sq.ft (0.46 m ²)
Mean span	4 ft 1 in (1.24 m)

D. Wing flaps

Unit area	10 sq.ft (0.93 m ²)
Mean span	8 ft 4.4 in (2.55 m)

E. Horizontal stabilizer

Span (Dimension E)	10 ft 6 in (3.20 m)
Stabilator area, anti-tab included	26.73 sq.ft (2.48 m ²)

Anti-tab area 5.78 sq.ft (0.54 m²)

Anti-tab automaticity 85 %

F. Vertical stabilizer

Fin area 11.15 sq.ft (1.036 m²)

Rudder area 6.78 sq.ft (0.63 m²)

G. Landing gears

Track (Dimension F) 7 ft 6.5 in (2.30 m)

Wheel base (Dimension G) 6 ft 3.6 in (1.92 m)

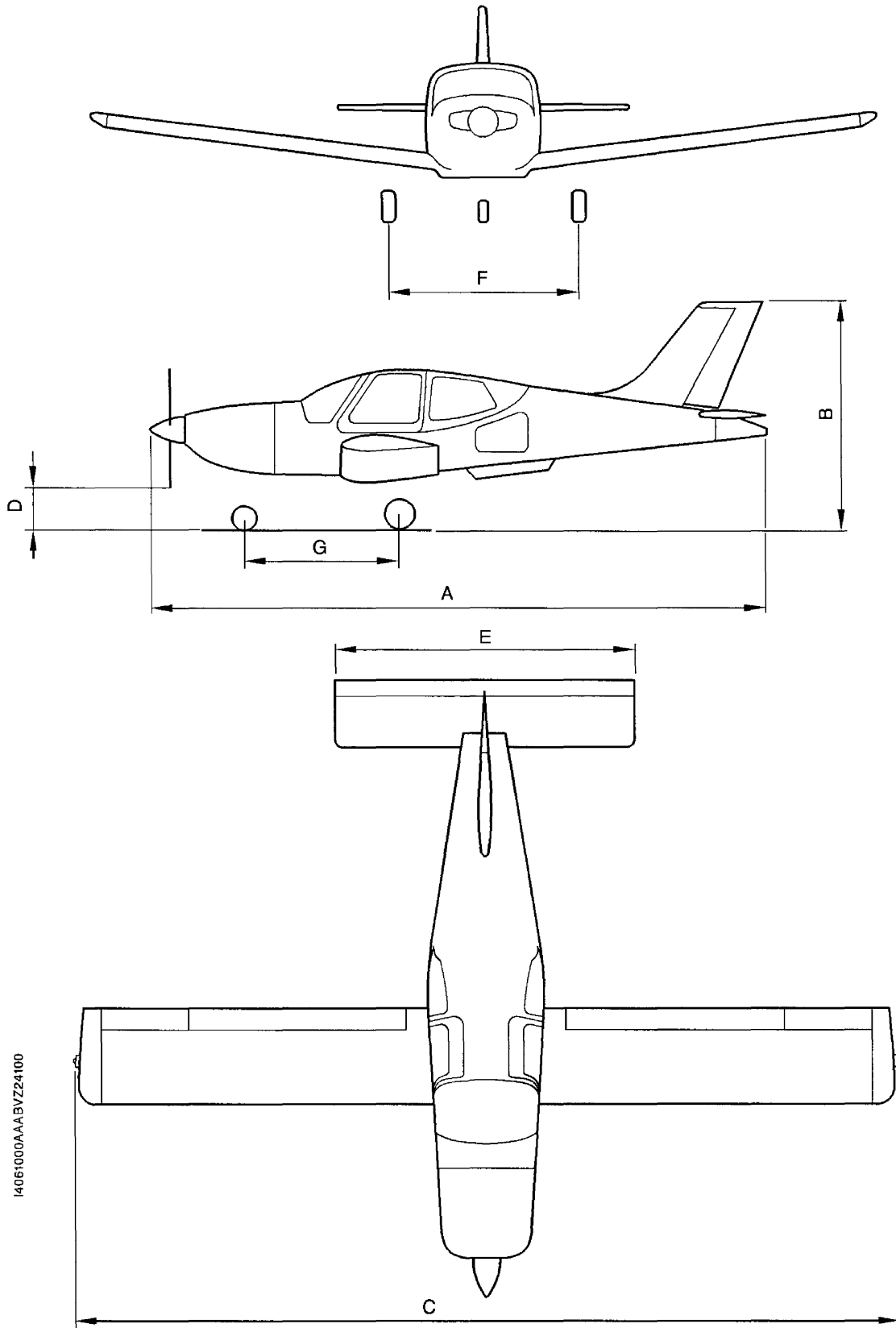

1406100AAA.BVZ24100

Three-view drawing
Figure 1

PAGE INTENTIONALLY LEFT BLANK

AREA LOCATIONS

DESCRIPTION AND OPERATION

1. GENERAL

In order to ensure accessibility to the various maintenance stations, the aircraft is divided up into several areas.

Each area is large enough to be subdivided into secondary areas which are easily defined in relation to structural markings.

The aircraft is composed of six primary areas :

Area 100 : Power plant

Area 200 : Fuselage

Area 300 : Empennages

Area 500 : L.H. wing

Area 600 : R.H. wing

Area 700 : Landing gear

2. DESCRIPTION (Figures 1, 2, 3, 3A and 3B)

A. Area 100

This area is composed of the FWD section of the aircraft, from the propeller spinner to the firewall (frame C0).

It is subdivided into three secondary areas :

- Area 110 : Propeller spinner
- Area 120 : Upper section of power plant
- Area 130 : Lower section of power plant

B. Area 200

This area is composed of the fuselage section located behind the firewall, including the tail cone.

It is subdivided into five secondary areas :

- Area 210 : FWD fuselage - external area between the firewall and frame C6
- Area 220 : Rear fuselage - from frame C6, including tail cone
- Area 230 : Cockpit - internal area between the firewall and the back of the rear seat except for control station
- Area 240 : Upper duct and baggage compartment - internal upper duct area and internal area between the back of rear seat and the AFT baggage compartment bulkhead (frame C6)
- Area 250 : Control station - internal area comprising instrument panel and upper surface of pedestal

C. Area 300

This area is composed of the horizontal and vertical stabilizers.

It is subdivided into three secondary areas :

- Area 310 : Fixed vertical stabilizer
- Area 320 : Rudder
- Area 330 : Stabilator

D. Area 500

This area is composed of the L.H. wing.

It is subdivided into three secondary areas :

- Area 510 : Wing lower surface
- Area 520 : Wing upper surface
- Area 530 : Wing interior

E. Area 600

Similar to area 500, this area is composed of the R.H. wing.

It is subdivided into two secondary areas :

- Area 610 : Wing lower surface
- Area 620 : Wing upper surface

F. Area 700

This area consists of the landing gear assembly.

It is subdivided into three secondary areas :

- Area 710 : Nose landing gear
- Area 730 : L.H. main landing gear
- Area 740 : R.H. main landing gear

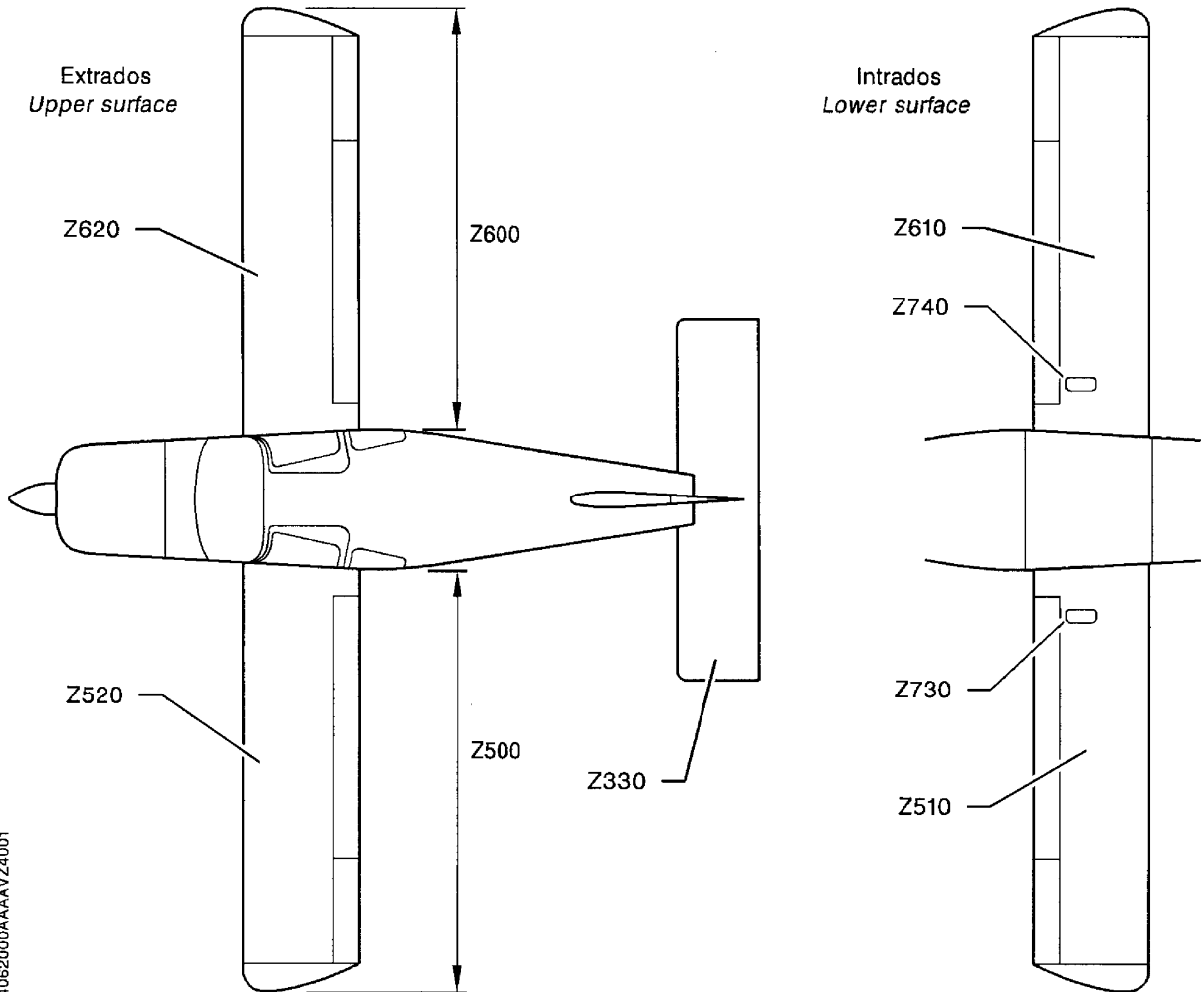
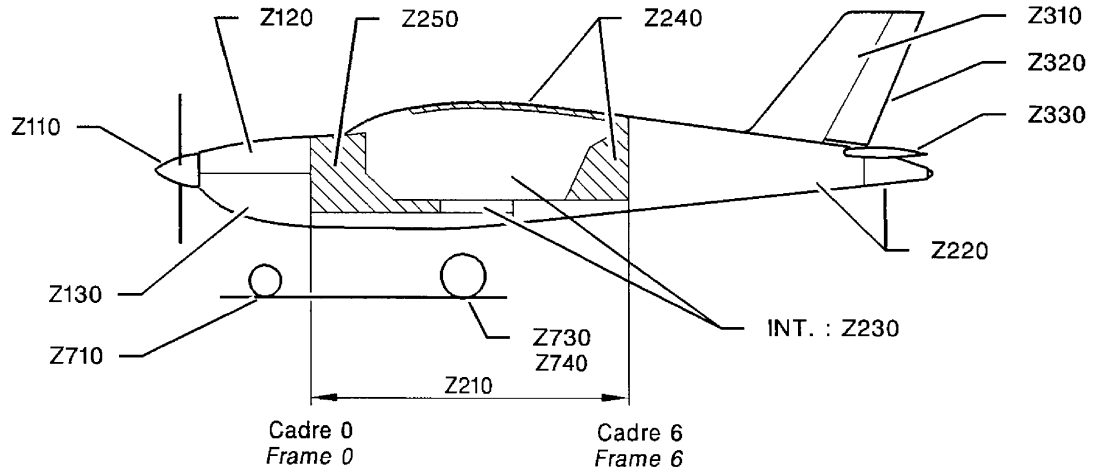

Location of areas
Figure 1

14062000AAA/VZ4001

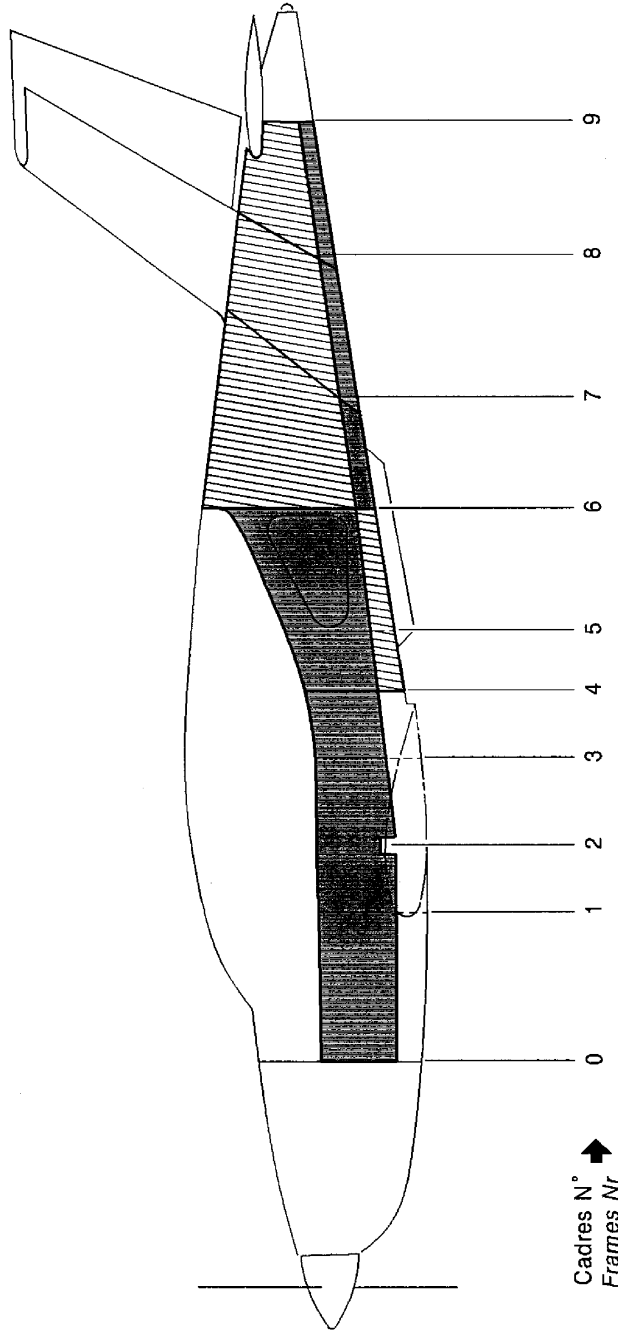

I4062000AAAAVZ4200

Location of fuselage frames
Figure 2

AAAA
Validity : S / N 1 - 9999

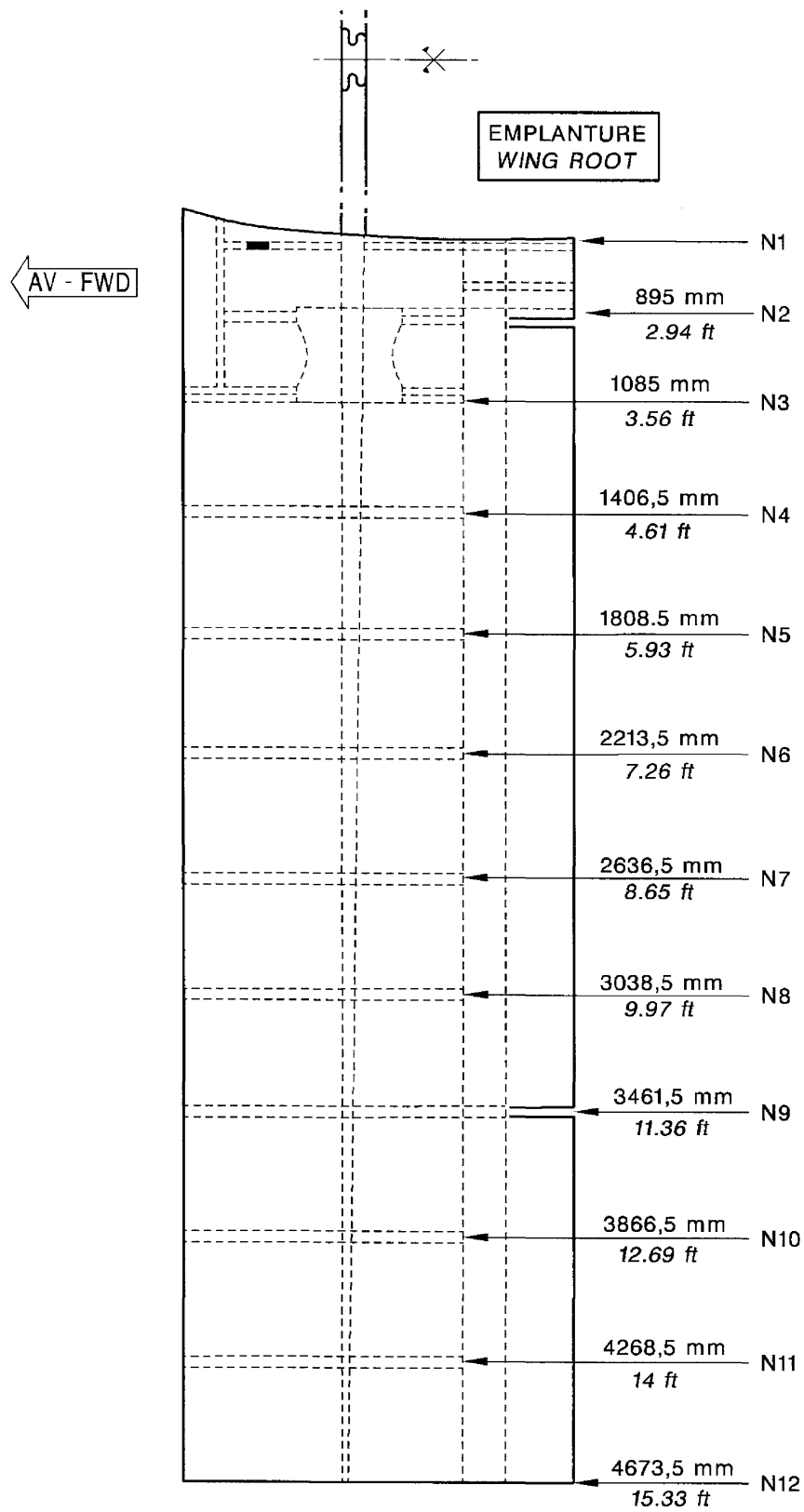

Location of wing ribs
Figure 3 - S / N 1 - 274

14524000AAA HWZ1200

AAAA
Validity : S / N 1 - 9999

06-20-00 (BA)

Page 5
JUN 02

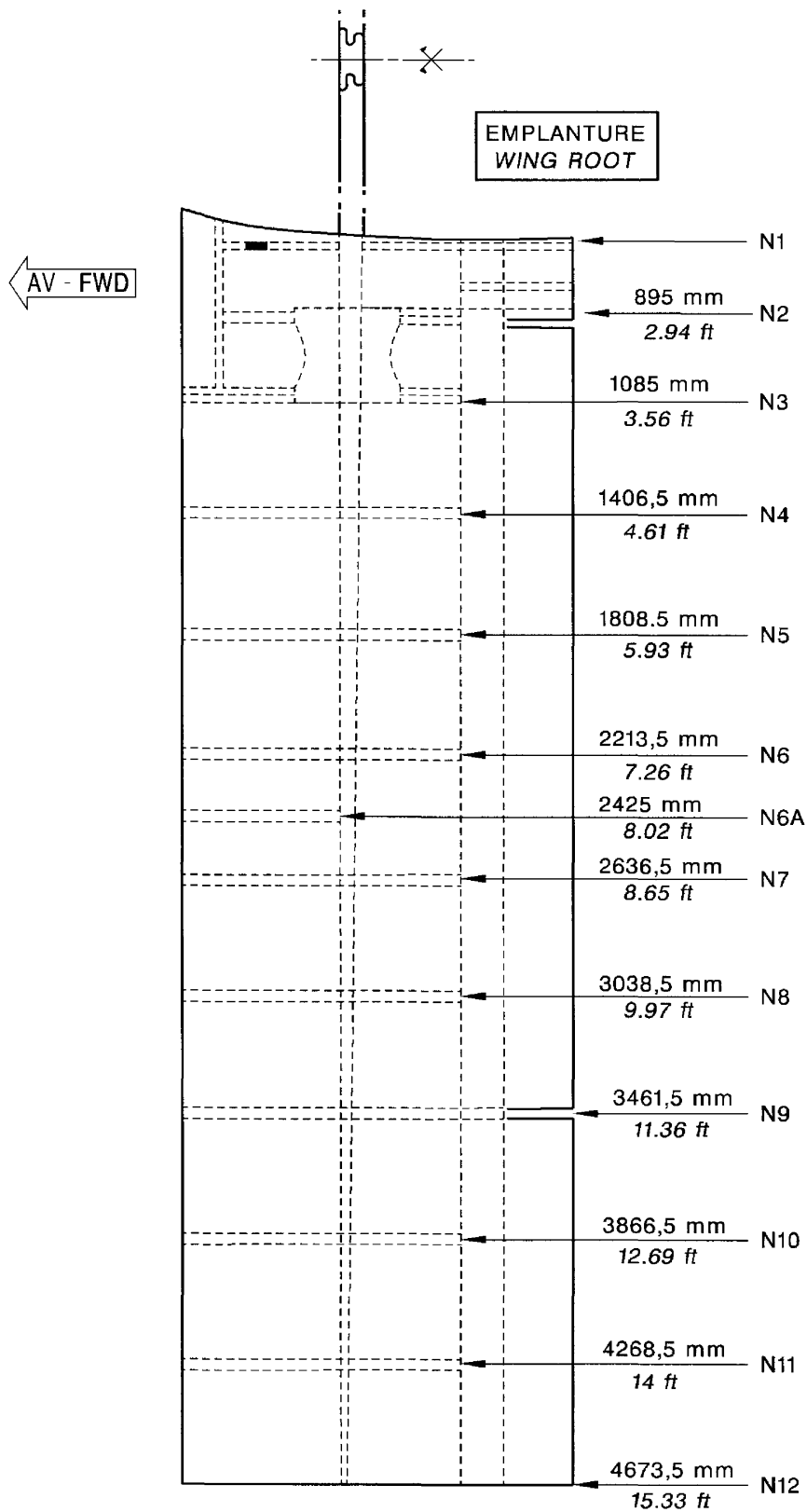

Location of wing ribs
Figure 3A - S / N 275 - 9999, without OPTION 558

14524000AAA HWZ14000

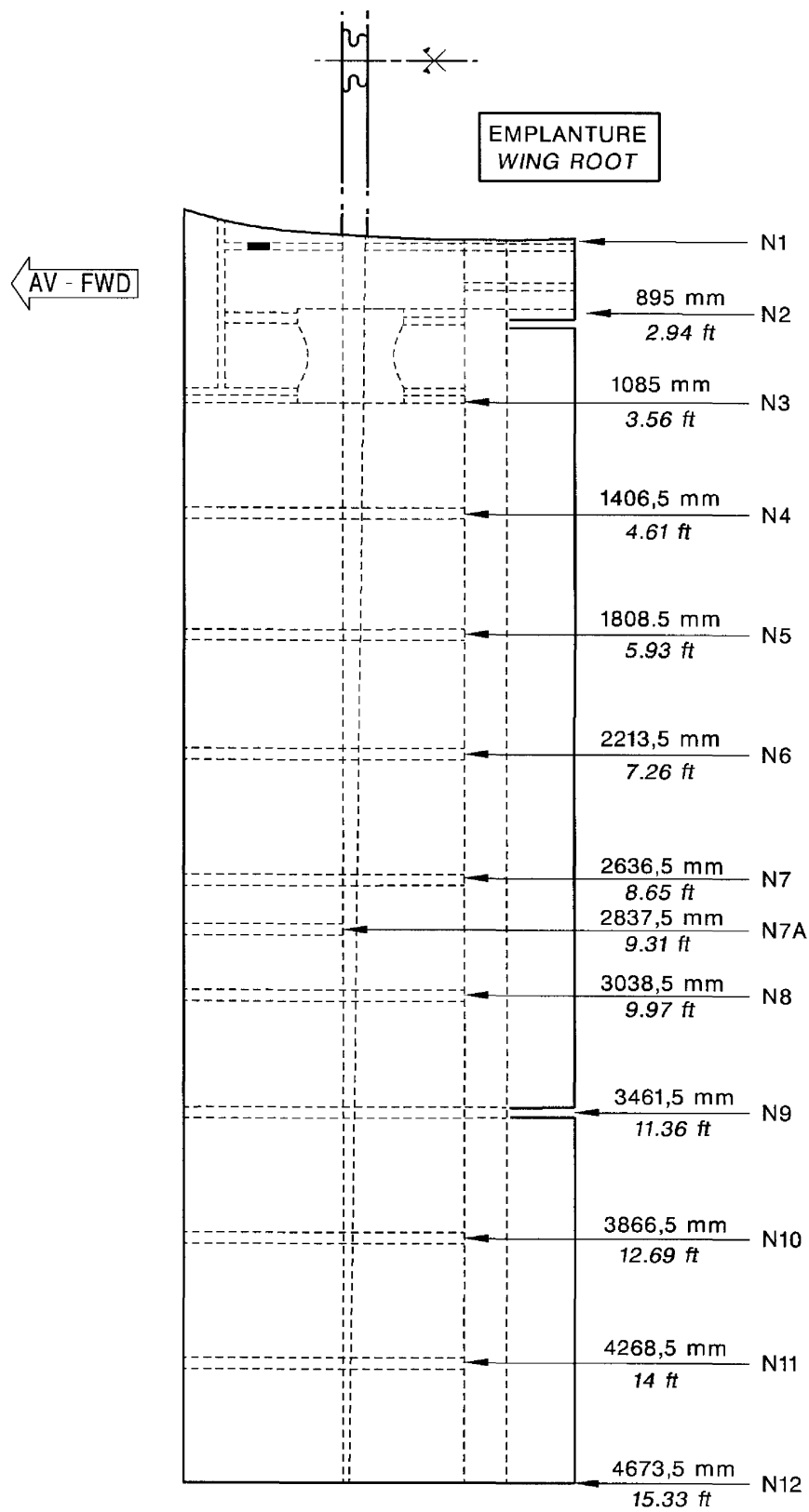

14524000AAA HWZ4100

Location of wing ribs
Figure 3B - S / N 275 - 764, 766 - 878, with OPTION 558

AAAA
Validity : S / N 1 - 9999

06-20-00 (BA)

Page 7
JUN 02

PAGE INTENTIONALLY LEFT BLANK

INSPECTION DOORS

DESCRIPTION AND OPERATION

1. GENERAL

The inspection or service doors generally include all openings which facilitate maintenance practices or which allow access to certain components.

To facilitate their localization, the inspection doors are identified by a three- or four-digit number, sometimes followed by a letter.

The first two digits are identical to the first two digits of the secondary area concerned - refer to 06-20-00. The final digit(s) is (are) the sequence number within the secondary area. This number is attributed in the following order : FWD - aft, interior - exterior, top - bottom. A letter "L" (left), "R" (right), "C" (center), "F" (FWD), "A" (Aft), "T" (top) or "B" (bottom) may be used to complete an element's identification.

Eg :

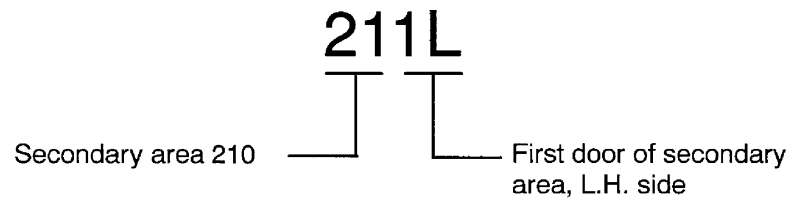

2. DESCRIPTION

A. Area 100 - Power plant (Figures 1 and 1A)

Identification No.	DESCRIPTION	AREA LOCATION AND ACCESSIBLE ELEMENTS
111	Propeller cone	Propeller attachment Propeller pitch adjustment screw
121	Power plant upper cowling	Power plant upper section Firewall upper FWD section Battery tray Brake hydraulic fluid tank Oil cooler Tachometer sensor
122	Inspection door	Oil gage
131	Power plant lower cowling	Power plant lower section Power plant rear table Firewall lower FWD section Engine air inlet Exhaust pipe and heat exchanger Injection unit Power plant fuel system Power plant oil system Propeller governor
132	Cover plate	Facilitates removal / installation of power plant lower cowling
133	Inspection door (if installed)	Engine quick drain

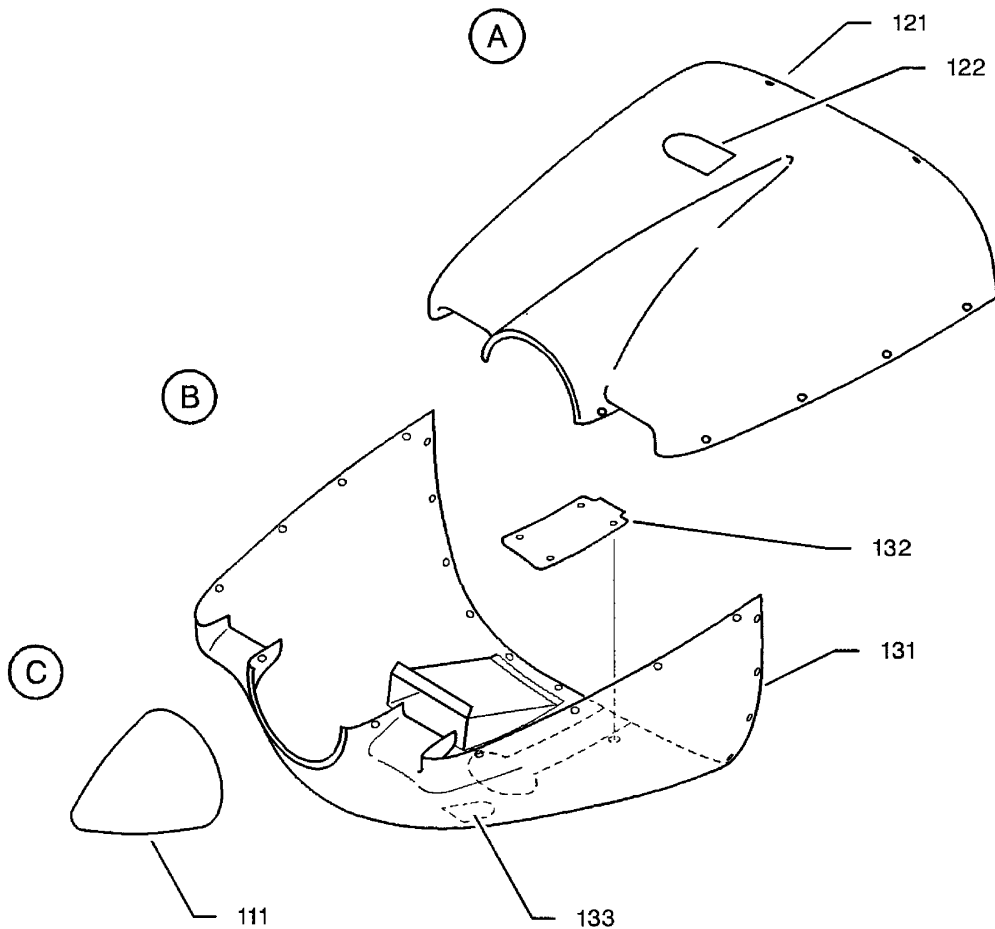
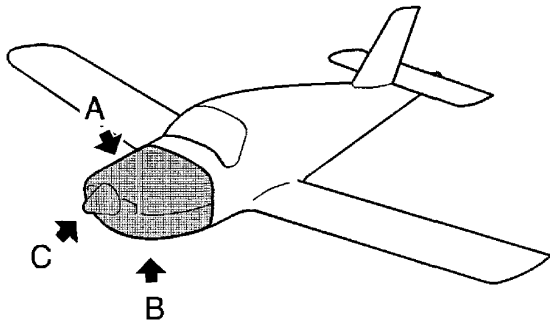

14524D00AAAOWZ24100

Inspection doors - Area 100
Figure 1 - S / N 1 - 387, 393 (in series)

AAAA
Validity : S / N 1 - 9999 Pre-MOD. 151

06-30-00 (BA)

Page 3
JUN 02

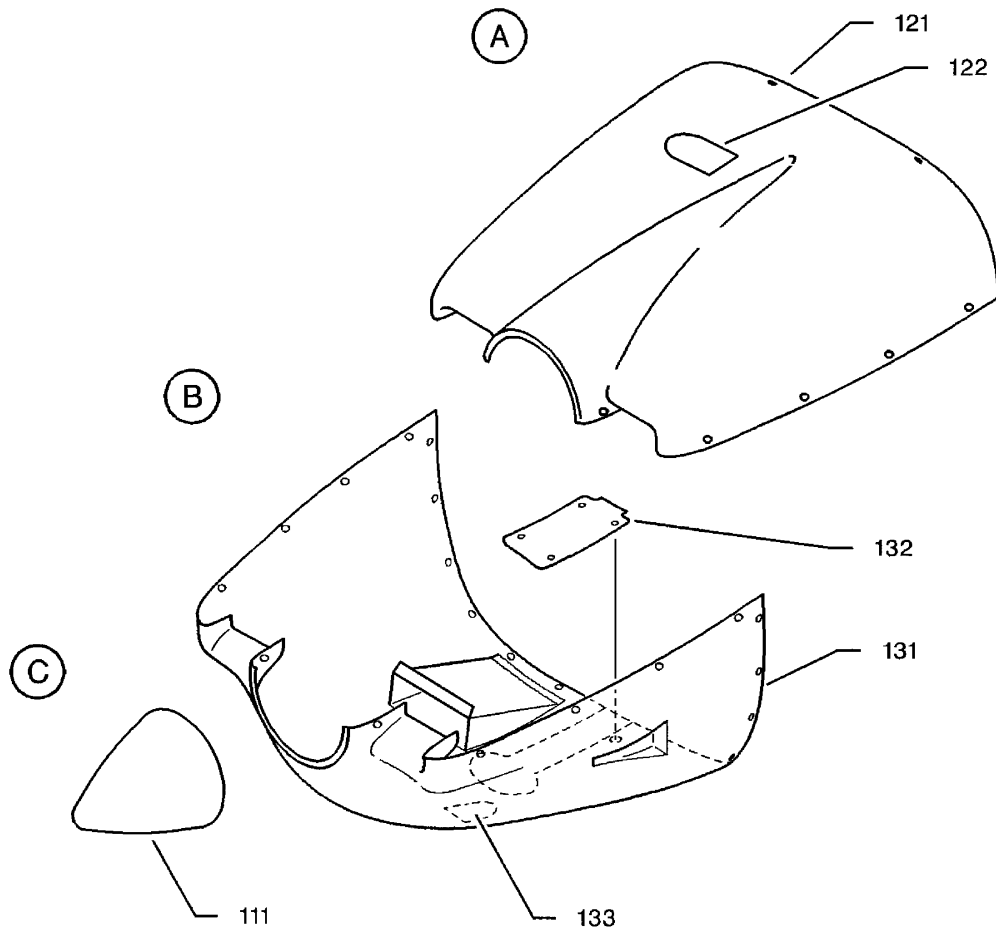
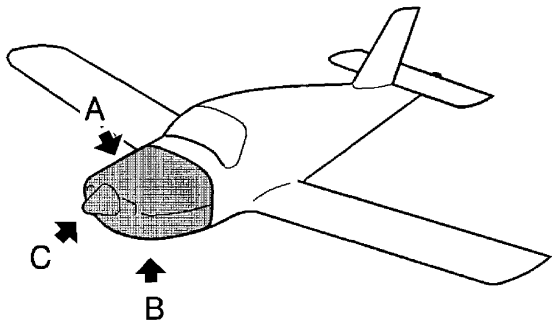

Inspection doors - Area 100
Figure 1A - S / N 1 - 387, 393 (in retrofit)
S / N 388 - 392, 394 - 9999 (in series)

1452400AAA0WZ4200

PAGE INTENTIONALLY LEFT BLANK

B. Area 200 - Fuselage

1) Area 210 - FWD fuselage (Figure 2)

Identification No.	DESCRIPTION	AREA LOCATION AND ACCESSIBLE ELEMENTS
211L	L.H. inspection door (if installed)	L.H. FWD table L.H. instrument panel FWD section Console upper section Vacuum system (if installed)
211R	R.H. inspection door (if installed)	R.H. FWD table R.H. instrument panel FWD section Console upper section Voltage regulator Radio console ventilator (if installed)
212L	Inspection door on firewall	Exterior light indicator printed circuit board Diode and fuse printed circuit board Alternator output indicator printed circuit board
212R	Inspection door (From S / N 1 - 822, 850 - 887, 889 - 947)	Voltage regulator
213L	Inspection door (From S / N 731)	Fuel system connection
214	Inspection door (From S / N 731)	Fuel pipe
215	Inspection door (From S / N 731)	Fuel selector / filter unit
216L	Inspection door (if installed)	Ground power receptacle (if installed)
217	Inspection door	Flap actuator
217L	L.H. junction fairing	L.H. wing FWD attachment to fuselage
217R	R.H. junction fairing	R.H. wing FWD attachment to fuselage
218	Cowling under hull	Wing / fuselage central attachments Wing / fuselage aft attachments Lower section of cabin floor-panels Fuel system Ram and static systems Brake system Wing and aft fuselage electric circuits Flaps relay and actuator Autopilot servo-actuator and aileron linkage (if installed) Gaging conditioner
219	Baggage compartment door	Baggage compartment (from outside)

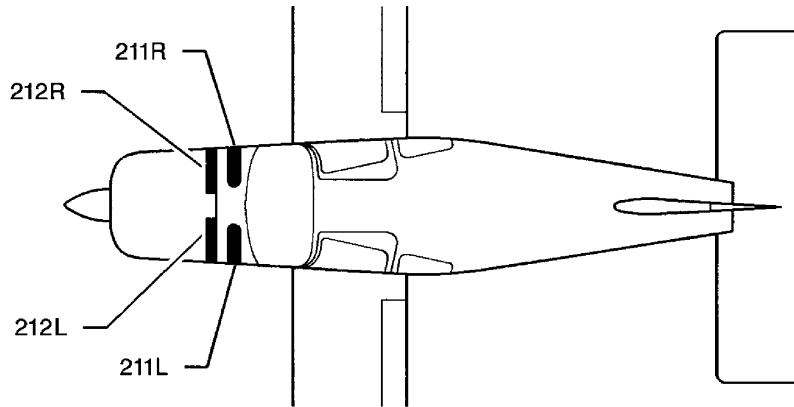
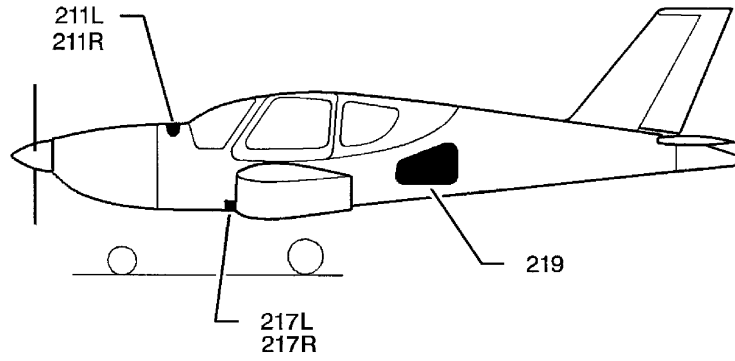

Intrados voilure gauche
L.H. wing lower surface

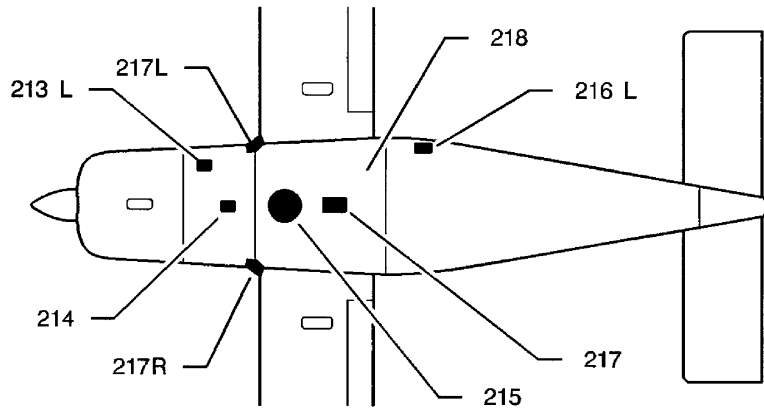

Intrados voilure droite
R.H. wing lower surface

Inspection doors - Area 210
Figure 2

14063000AAA-BWZ14000

2) Area 220 - Aft fuselage (Figure 3)

Identification No.	DESCRIPTION	AREA LOCATION AND ACCESSIBLE ELEMENTS
221	Blanking cap	Rudder lower hinge
222	Aft fuselage cone	Elevator hinge Elevator trim actuator Rudder steering linkage Aft navigation light (if installed)

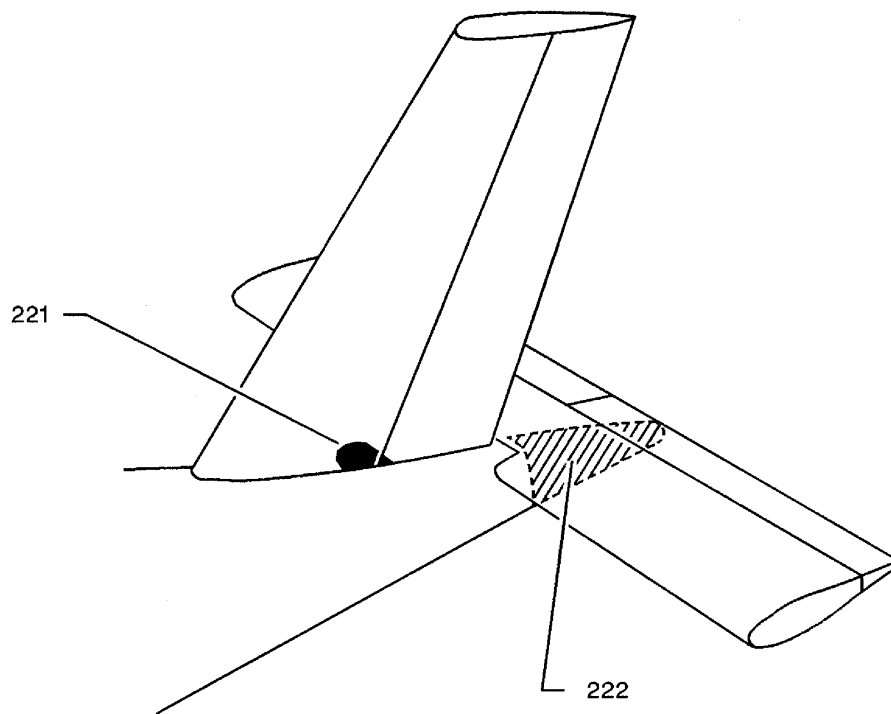

I4550000AAAAAYZ4000

Inspection doors - Area 220
Figure 3

AAAA
Validity : S / N 1 - 9999 Pre-MOD. 151

06-30-00 (BA)

Page 9
JUN 02

3) Area 230 - Cockpit (Figure 4)

Identification No.	DESCRIPTION	AREA LOCATION AND ACCESSIBLE ELEMENTS
231L	FWD L.H. side furnishings	Electric circuit routing FWD L.H. NACA water outlet VHF 1 feeder
231R	FWD R.H. side furnishings	Electric circuit routing FWD R.H. NACA water outlet VOR feeder
232L	Circuit-breaker panel	Circuit-breaker and bus bar electric connections FWD L.H. NACA water outlet VHF 1 feeder
232R	Map holder	VOR feeder
233L	L.H. door lower furnishings	L.H. access door locking mechanism Pilot seat belt L.H. FWD lower attachment NACA water outlet and L.H. door mechanism VHF 1 feeder
233R	R.H. door lower furnishings	R.H. access door locking mechanism. Front passenger seat belt R.H. lower FWD attachment NACA water outlet and R.H. door mechanism VOR feeder
234L	L.H. aft furnishings	L.H. FWD seat belt reel Aft lateral seat belt external attachment
234R	R.H. aft furnishings	R.H. FWD seat belt reel Aft lateral seat belt external attachment
235L	L.H. side inspection door	Console lower section Pedals FWD lower air conditioning
235R	R.H. side inspection door	Console lower section Pedals FWD lower air conditioning
236	Tunnel	Aft lower air conditioning Flight control linkage and sealing bellows Ram and static air systems Braking system Aft fuselage and wing electric circuits
237	Mike support plate	Electric connections for micro plugs and head-set

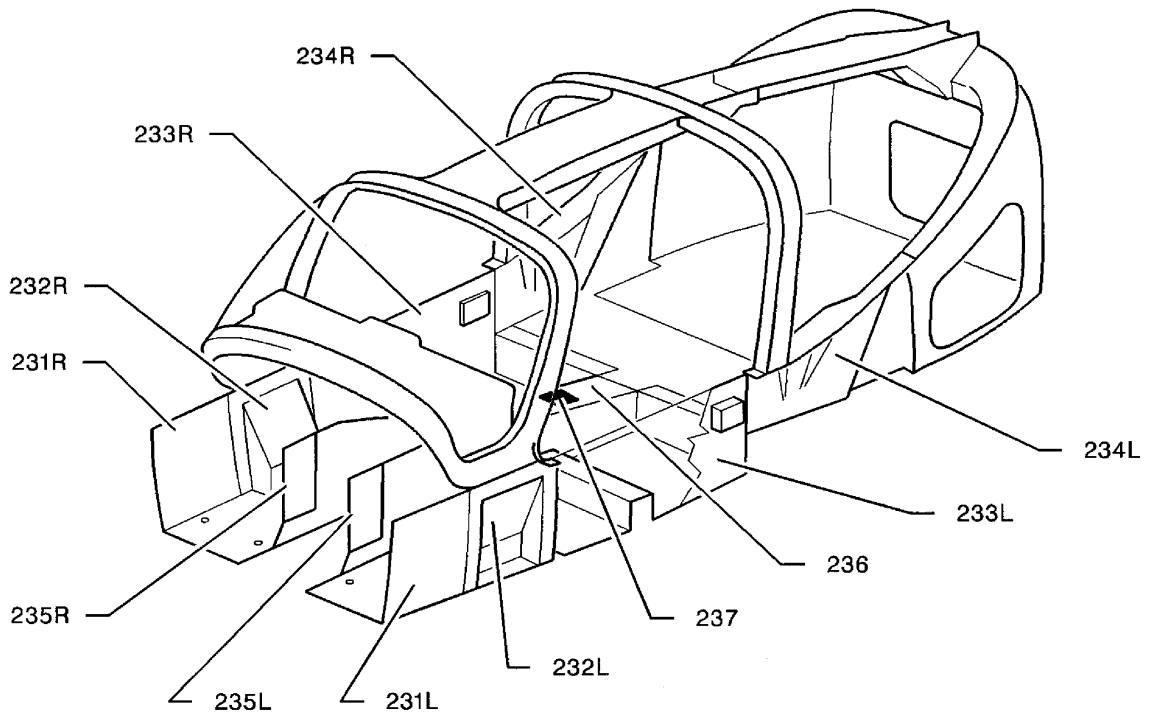

14251600AAAAAYZ14200

Inspection doors - Area 230
Figure 4

4) Area 240 - Upper duct and baggage compartment (Figure 5)

Identification No.	DESCRIPTION	AREA LOCATION AND ACCESSIBLE ELEMENTS
241	Overhead panel	Upper air conditioning Cabin lighting Emergency lighting Antenna fastenings and feeders on upper duct (if installed) Aural warnings Loud-speaker (if installed)
242	Baggage compartment bottom door	Aft fuselage interior Flight control linkage Autopilot horizontal stabilizer servo-actuators and trim (if installed) Static air system Flashing units (if installed)
244C	Inspection door (if installed)	ADF 2 antenna (if installed)
249	Cover	Stormscope (if installed) UHF transceiver (if installed)

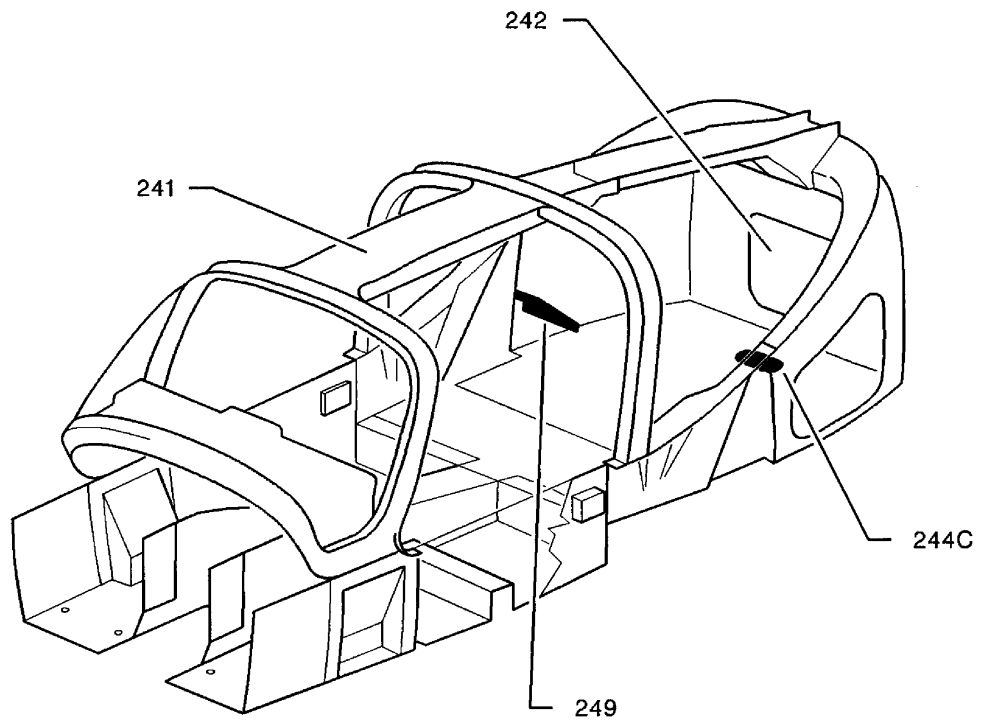

14251600AAAAYZ14100

Inspection doors - Area 240
Figure 5

AAAA
Validity : S / N 1 - 9999 Pre-MOD. 151

5) Area 250 – Main control station (Figure 6)

Identification No.	DESCRIPTION	AREA LOCATION AND ACCESSIBLE ELEMENTS
251C	Central console	Instruments located on central console
251L	L.H. instrument panel	Instruments located on L.H. instrument panel
251R	R.H. instrument panel	Instruments located on R.H. instrument panel
252	Pedestal FWD cover	Wing flap control and pull-off type circuit-breaker electric connections Engine controls Lower air conditioning Flight control linkage Ram air system Brake system Aft fuselage and wing electric circuits
253	Pedestal aft cover	Lighter electric connection Engine controls Lower air conditioning Flight control linkage Fuel selector valve linkage (S / N 731 - 9999) Static and ram air systems Brake system Aft fuselage and wing electric circuits
254L	L.H. panel strip	Pilot air outlet Magneto / start selector Parking brake knob Fuel selector valve control (S / N 1 - 730) Hourmeter (if installed) Stormscope (if installed) Radio Master Switch (if installed) Emergency static source valve (if installed) Pressure indicator (if installed)
254R	R.H. panel strip	Front passenger air outlet Air conditioning control Transponder (if installed) Hourmeter (if installed)

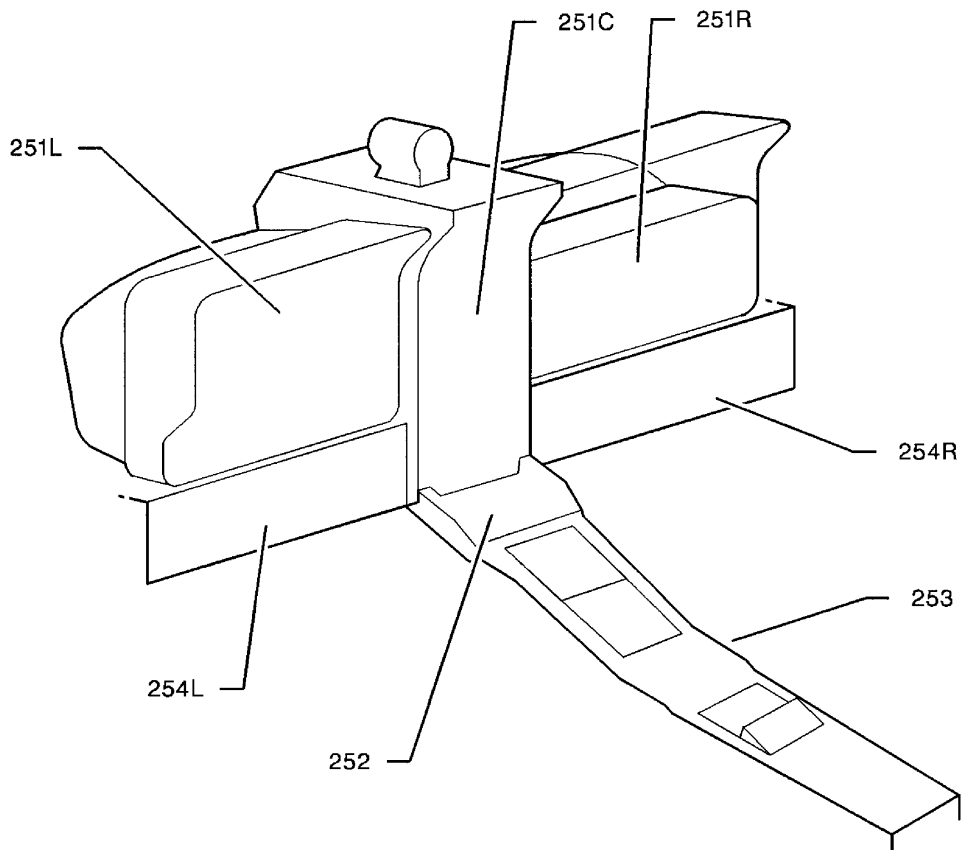

14063000AAAACWZ4000

Inspection doors - Area 250
Figure 6

AAAA
Validity : S / N 1 - 9999 Pre-MOD. 151

06-30-00 (BA)

Page 15
JUN 02

C. Area 300 - Stabilizers (Figure 7)

Identification No.	DESCRIPTION	AREA LOCATION AND ACCESSIBLE ELEMENTS
311	Vertical stabilizer tip	Antenna access and anti-collision light (if installed)

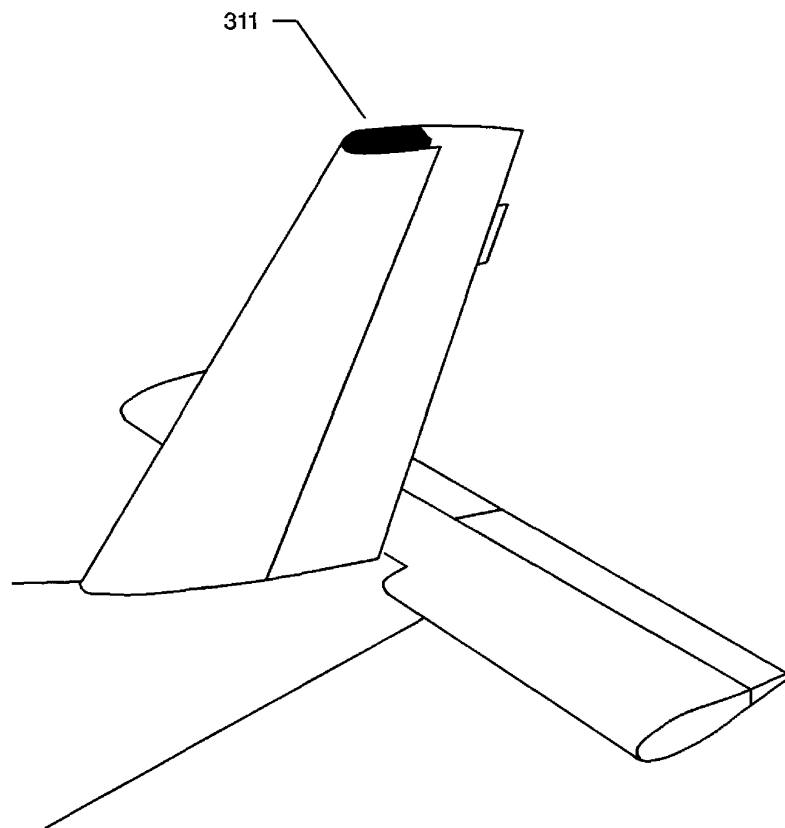

1455000AAAAAYZ4200

Inspection doors - Area 300
Figure 7

AAAA
Validity : S / N 1 - 9999 Pre-MOD. 151

D. Areas 500 / 600 - Wing (Figures 8 and 9)

1) Area 500 - L.H. wing

Identification No.	DESCRIPTION	AREA LOCATION AND ACCESSIBLE ELEMENTS
511	Inspection door	Wing root area in front of spar Spar (FWD side) Aileron linkage Fuel supply lines Fuel strainer (tank outlet)
512	Inspection door	Wing root area behind spar Spar (rear side) Aileron bellcrank Fuel tank air vent (outlet) Root gage (float gage) L.H. main landing gear upper attachment Electric wiring Capacity gage oscillator
513	Inspection door	Tank area Capacity gage sensor Low level detector (option)
514	Inspection door	Tank area Capacity gage sensor Air vent (tank interior)
515	Inspection door	Central area behind spar Spar (rear side) Aileron linkage Rigid air vent pipes Wing tip gage (float gage) Capacity gage oscillator
516	Inspection door	End area behind spar Spar (rear side) Aileron bellcrank Aileron control rod Air vent hose
517	Wing tip	Navigation light Anti-collision light Internal end area Light control box (if installed)
518	Inspection door (Post-MOD. 93)	Main landing gear attachment pin
521	Fuel plug	Tank (filling) Fuel gage
522	Light protection	Taxi light Landing light
523	Inspection door	Flux valve if aircraft equipped with radar
531	Inspection door	Fuel tank

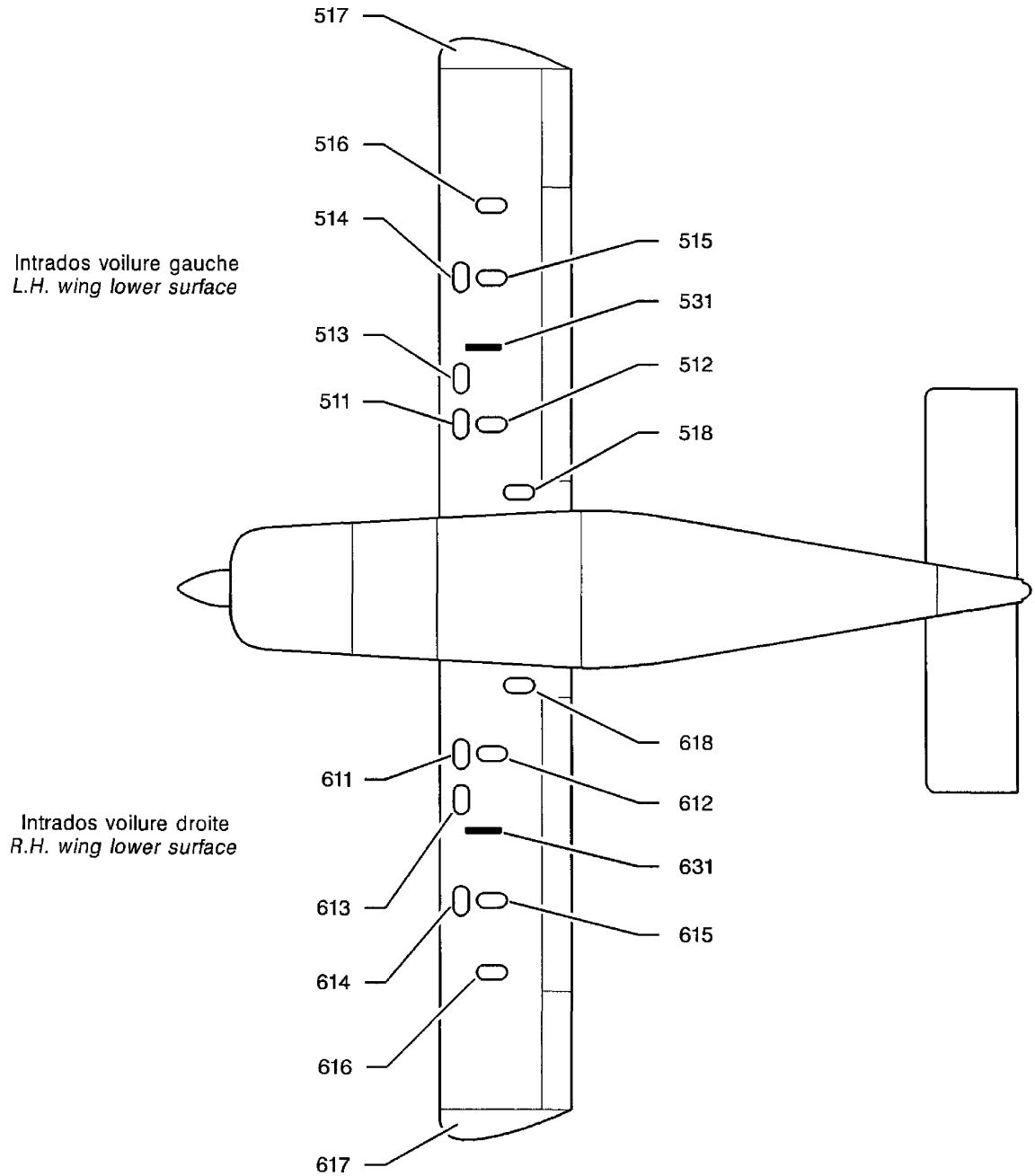

Inspection doors - Areas 500 / 600 - Lower surface and interior
Figure 8

14063000AAAAVZ4000

2) Area 600 - R.H. wing

Identification No.	DESCRIPTION	AREA LOCATION AND ACCESSIBLE ELEMENTS
611	Inspection door	Wing root area in front of spar Spar (FWD side) Aileron linkage Fuel supply line Fuel strainer (tank outlet)
612	Inspection door	Wing root area behind spar Spar (rear side) Aileron bellcrank Fuel tank air vent (outlet) Wing root gage (float gage) L.H. main landing gear upper attachment Electric wiring Capacity gage oscillator
613	Inspection door	Tank area Capacity gage sensor Low level detector (option)
614	Inspection door	Tank area Capacity gage sensor Air vent (tank interior)
615	Inspection door	Center area behind spar Spar (rear side) Aileron linkage Wing tip gage (float gage) Air vent hose Capacity gage oscillator
616	Inspection door	End area behind spar Spar (rear side) Aileron bellcrank Aileron control rod Air vent hose
617	Wing tip	Navigation light Anti-collision light Internal end area
618	Inspection door (Post-MOD. 93)	Main landing gear attachment pin
621	Fuel plug	Tank (filling) Fuel gage
622	Inspection door	Flux valve
631	Inspection door	Fuel tank

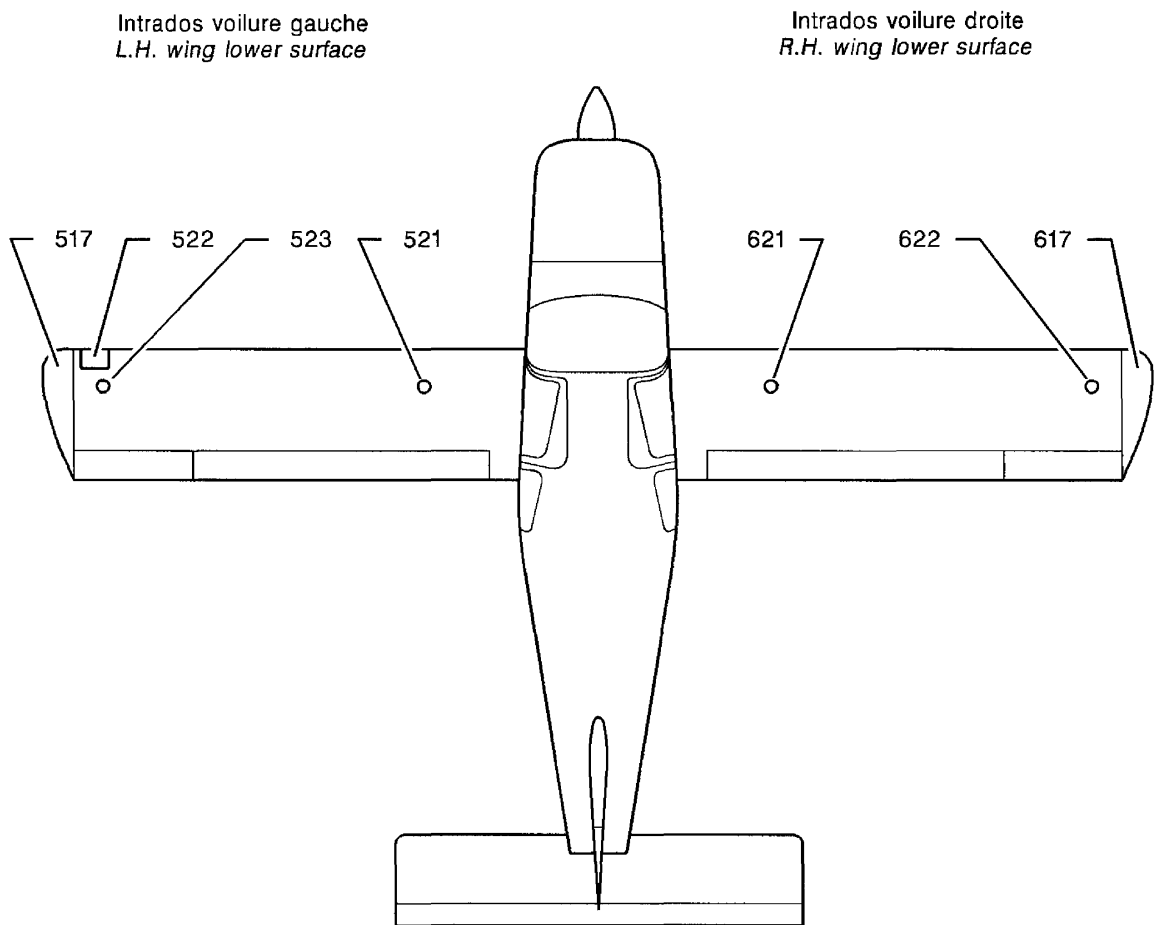

14063000AAAAVZ14200

Inspection doors - Areas 500 / 600 - Upper surface
Figure 9

E. Area 700 - Landing gear

1) Telescopic leg main landing gear

S / N 1 - 764, 766 - 878 Pre-MOD. 72 and S / N 1851 - 9999 (Figure 10)

Identification No.	DESCRIPTION	AREA LOCATION AND ACCESSIBLE ELEMENTS
711	FWD fairing	Nose landing gear lower section and wheel
712	Aft fairing	Nose landing gear lower section and wheel
713	Inspection door	Nose wheel valve
731	Wing / L.H. main landing gear junction cover	L.H main landing gear attachment to wing
732	L.H. main landing gear leg FWD fairing	L.H. main landing gear leg
733	L.H. main landing gear leg aft fairing	L.H. main landing gear leg and brake system
734	L.H. main landing gear wheel fairing	L.H. wheel and axle assy
735	Door	L.H. brake cylinder and disk
736	Door	L.H. wheel valve
741	Wing / R.H. main landing gear junction cover	R.H. main landing gear attachment to wing
742	R.H. main landing gear body FWD fairing	R.H. main landing gear leg
743	R.H. main landing gear body aft fairing	R.H. main landing gear leg and brake system
744	R.H. main landing gear wheel fairing	R.H. wheel and axle assy
745	Door	R.H. brake cylinder and disk
746	Door	R.H. wheel valve

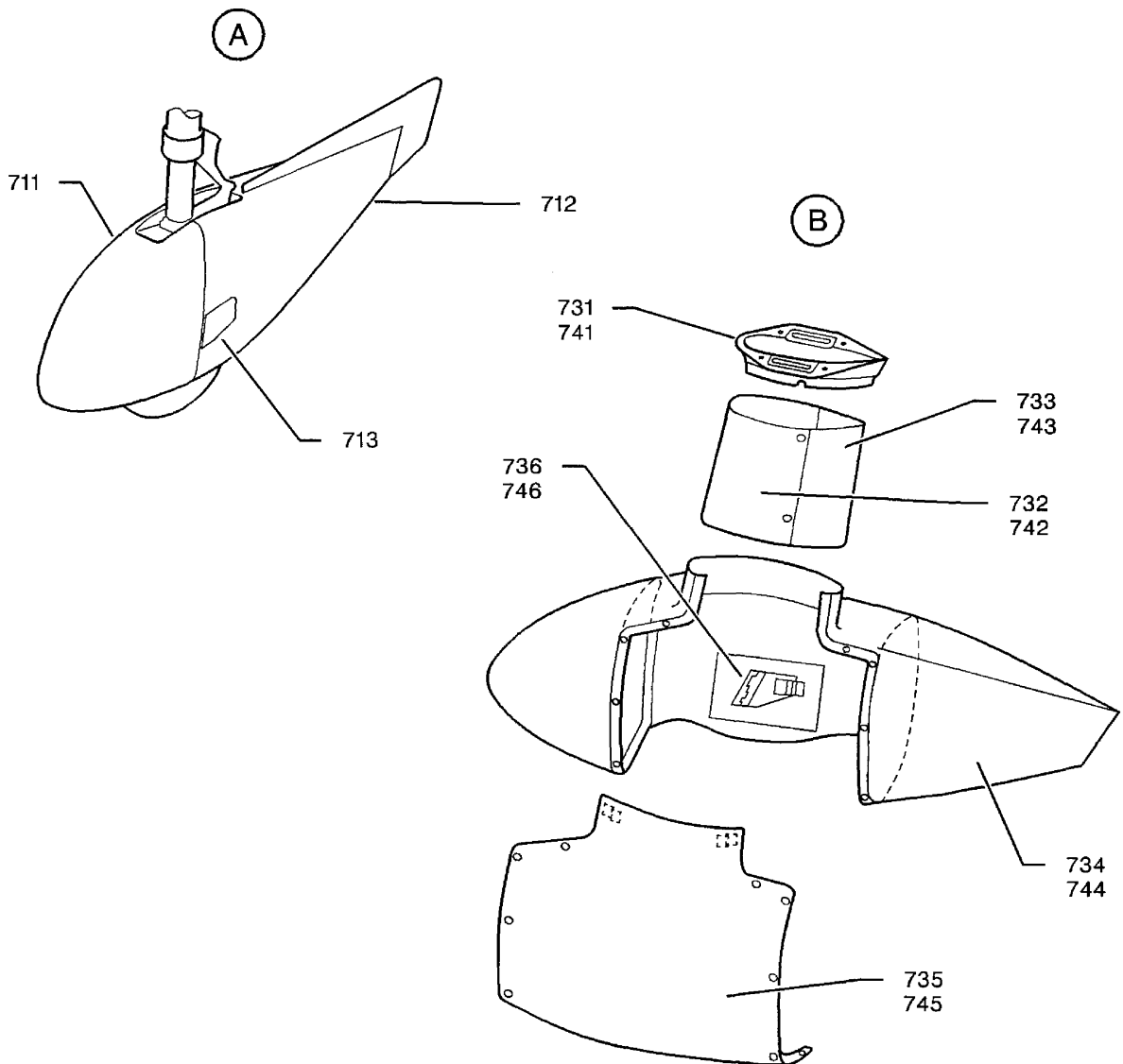
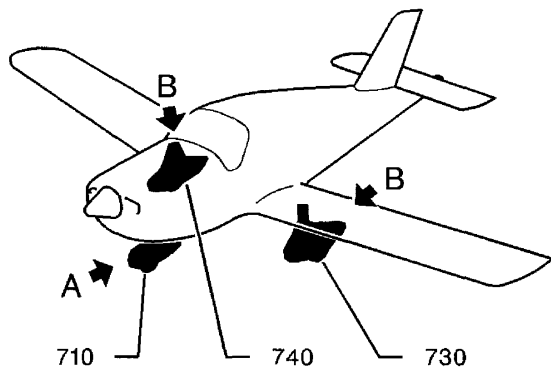

Inspection doors - Area 700
Figure 10

14321004AAACYZ4000

AAAA
Validity : S / N 1 - 9999 Pre-MOD. 151

S / N 765, 879 - 1850 and S / N 1 - 764, 766 - 878 Post-MOD. 72 (Figure 11)

Identification No.	DESCRIPTION	AREA LOCATION AND ACCESSIBLE ELEMENTS
714	Trim	Front wheel and axle attachment
731	Wing / L.H. main landing gear junction cover	L.H. main landing gear attachment to wing
737	Trim	L.H. wheel and axle attachment
741	Wing / R.H. main landing gear junction cover	R.H. main landing gear attachment to wing
747	Trim	R.H. wheel and axle attachment

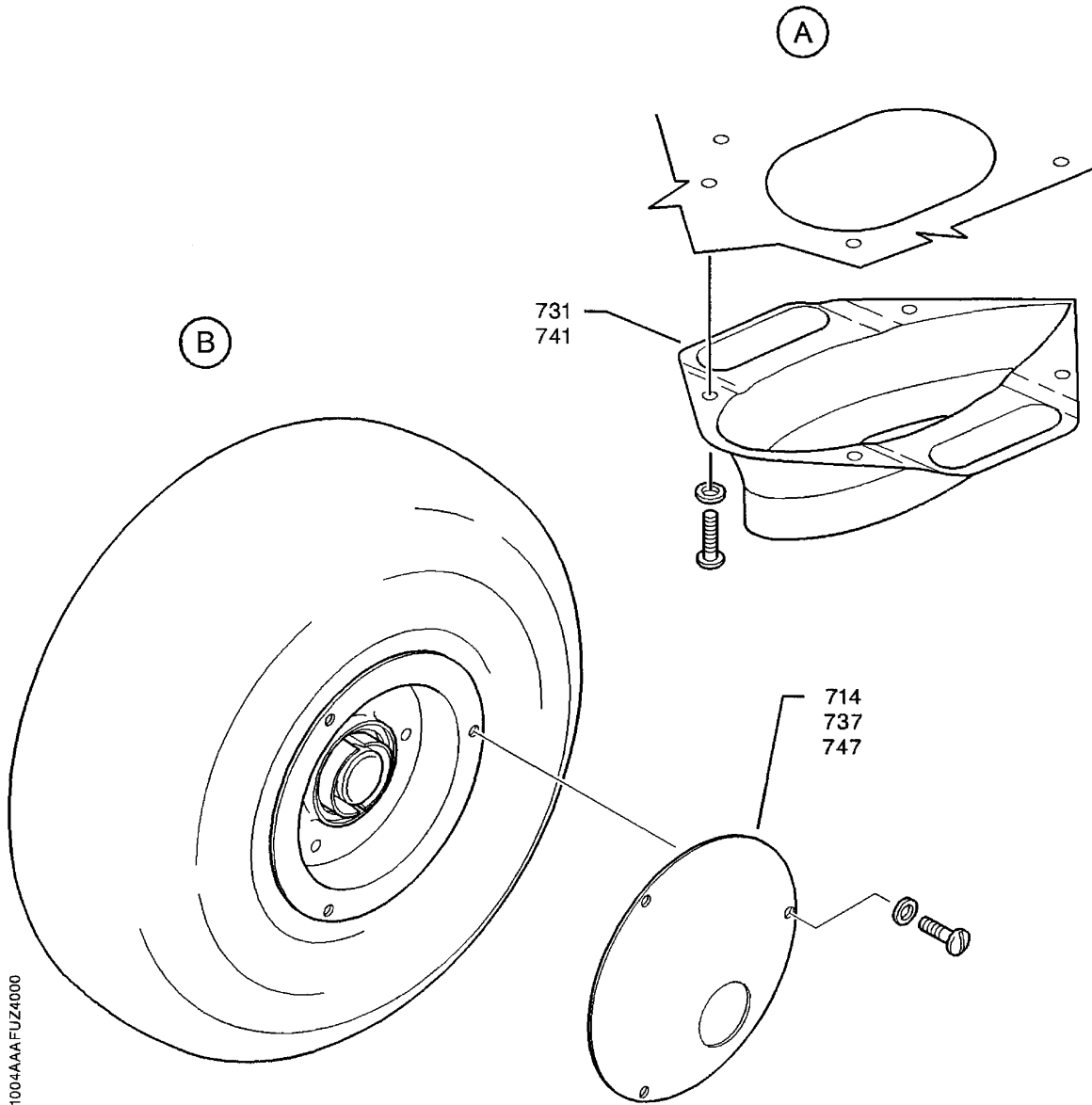
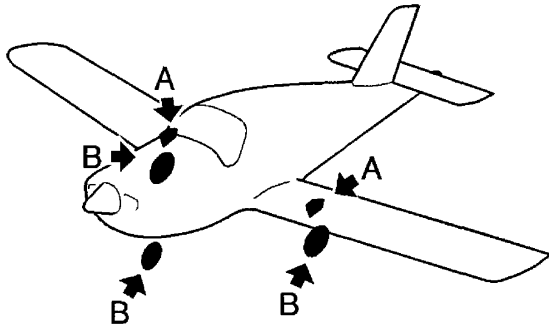

I4321004AAA FUZ4000

Inspection doors - Area 700
Figure 11

AAAA
Validity : S/N 1 - 9999 Pre-MOD. 151

06-30-00 (BA)

Page 25
JUN 02

2) Trailing arm main landing gear (Figure 12)

Identification No.	DESCRIPTION	AREA LOCATION AND ACCESSIBLE ELEMENTS
711	FWD fairing	Nose landing gear lower section and wheel
712	Aft fairing	Nose landing gear lower section and wheel
713	Inspection door	Nose wheel valve
734	L.H. inboard half-fairing	L.H. wheel and axle assy
735	L.H. outboard half-fairing	L.H. brake cylinder and disk
736	Inspection door	L.H. wheel valve
744	R.H. inboard half-fairing	R.H. wheel and axle assy
745	R.H. outboard half-fairing	R.H. brake cylinder and disk
746	Inspection door	R.H. wheel valve

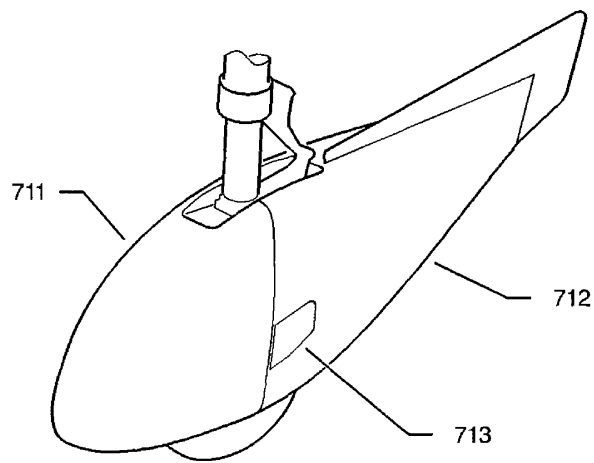
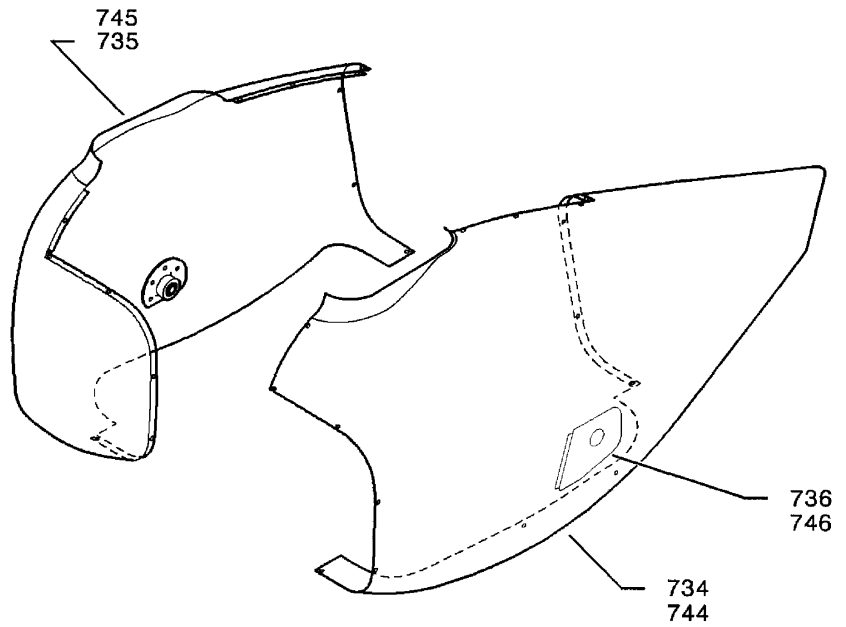
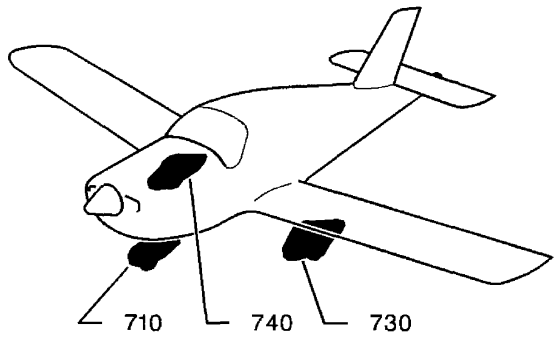

Inspection doors - Area 700
Figure 12

M321024AAAAYZ4000

PAGE INTENTIONALLY LEFT BLANK

INSPECTION DOORS

DESCRIPTION AND OPERATION

1. GENERAL

The inspection or service doors generally include all openings which facilitate maintenance practices or which allow access to certain components.

To facilitate their localization, the inspection doors are identified by a three- or four-digit number, sometimes followed by a letter.

The first two digits are identical to the first two digits of the secondary area concerned - refer to 06-20-00. The final digit(s) is (are) the sequence number within the secondary area. This number is attributed in the following order : FWD - aft, interior - exterior, top - bottom. A letter "L" (left), "R" (right), "C" (center), "F" (FWD), "A" (Aft), "T" (top) or "B" (bottom) may be used to complete an element's identification.

Eg :

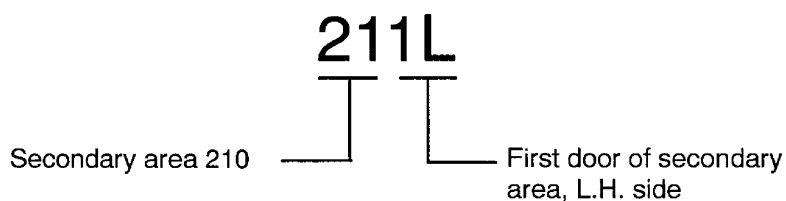

2. DESCRIPTION

A. Area 100 - Power plant (Figure 1)

Identification No.	DESCRIPTION	AREA LOCATION AND ACCESSIBLE ELEMENTS
111	Propeller cone	Propeller attachment Propeller pitch adjustment screw
121	Power plant upper cowling	Power plant upper section Firewall upper FWD section Battery tray Brake hydraulic fluid tank Oil cooler Tachometer sensor
122	Inspection door	Oil gage
131	Power plant lower cowling	Power plant lower section Power plant rear table Firewall lower FWD section Engine air inlet Exhaust pipe and heat exchanger Injection unit Power plant fuel system Power plant oil system Propeller governor
132	Cover plate	Facilitates removal / installation of power plant lower cowling
133	Inspection door (if installed)	Engine quick drain

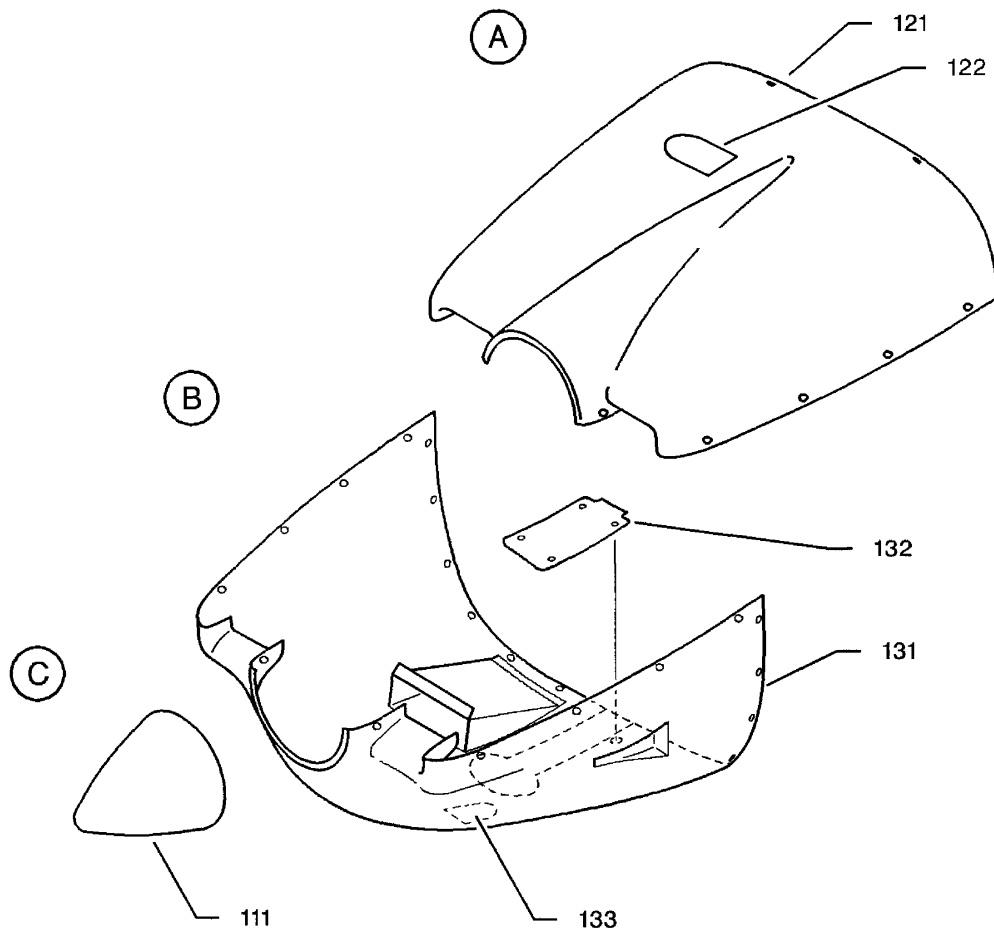
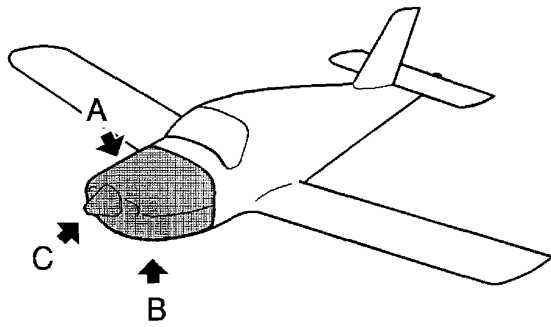

I4524000AAAOWZ4200

Inspection doors - Area 100
Figure 1

B. Area 200 - Fuselage

1) Area 210 - FWD fuselage (Figure 2)

Identification No.	DESCRIPTION	AREA LOCATION AND ACCESSIBLE ELEMENTS
211L	L.H. inspection door	L.H. FWD table L.H. instrument panel FWD section Console upper section Vacuum system
211R	R.H. inspection door	R.H. FWD table R.H. instrument panel FWD section Console upper section Voltage regulator Radio console ventilator (if installed)
212L	Inspection door on firewall	Exterior light indicator printed circuit board Diode and fuse printed circuit board Alternator output indicator printed circuit board
213L	Inspection door	Fuel system connection Fuel flowmeter sensor (if installed) Emergency vacuum system (if installed)
214	Inspection door	Electric boost pump Emergency vacuum system (if installed)
215	Inspection door	Fuel selector / filter unit
216L	Inspection door	Ground power receptacle
217	Inspection door	Flap actuator
217L	L.H. junction fairing	L.H. wing FWD attachment to fuselage
217R	R.H. junction fairing	R.H. wing FWD attachment to fuselage
218	Cowling under hull	Wing / fuselage central attachments Wing / fuselage aft attachments Lower section of cabin floor-panels Fuel system Ram and static systems Brake system Wing and aft fuselage electric circuits Flaps relay and actuator Autopilot servo-actuator and aileron linkage (if installed) Anti-collision lights power unit Emergency electromechanical vacuum pump (if installed) Gaging conditioner
219	Baggage compartment door	Baggage compartment (from outside)

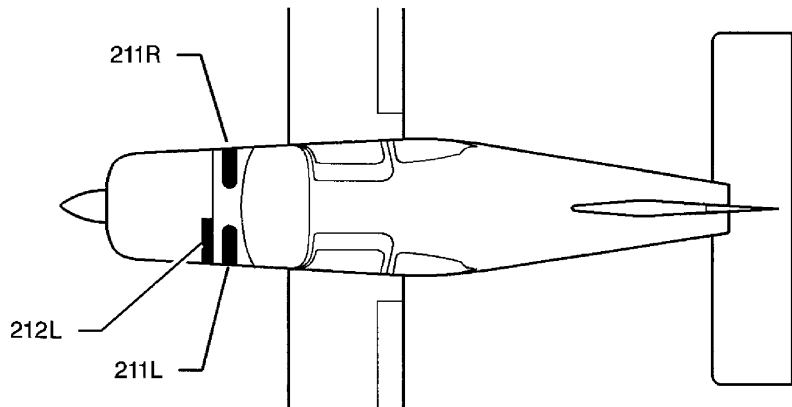
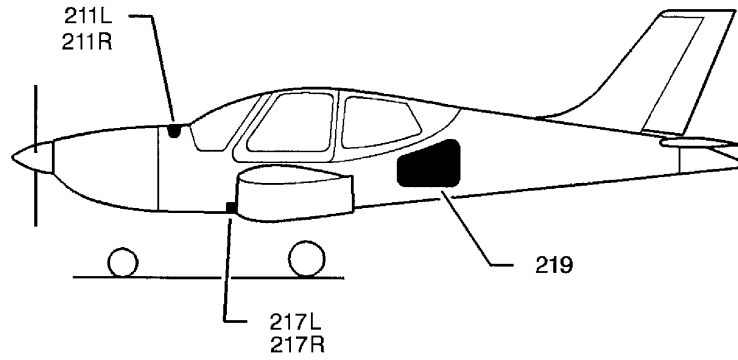

Intrados voilure gauche
L.H. wing lower surface

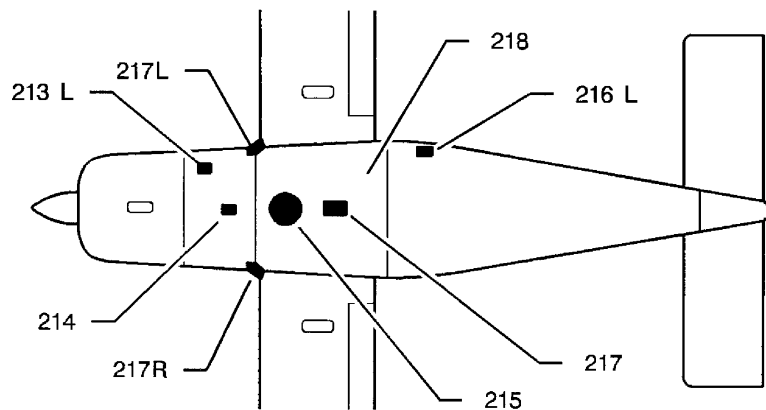

Intrados voilure droite
R.H. wing lower surface

Inspection doors - Area 210
Figure 2

14063000AAA BWZ14200

2) Area 220 - Aft fuselage (Figure 3)

Identification No.	DESCRIPTION	AREA LOCATION AND ACCESSIBLE ELEMENTS
221	Blanking cap	Rudder lower hinge
222	Aft fuselage cone	Elevator hinge Elevator trim actuator Rudder steering linkage
225	Dorsal fin	Vertical stabilizer / fuselage junction

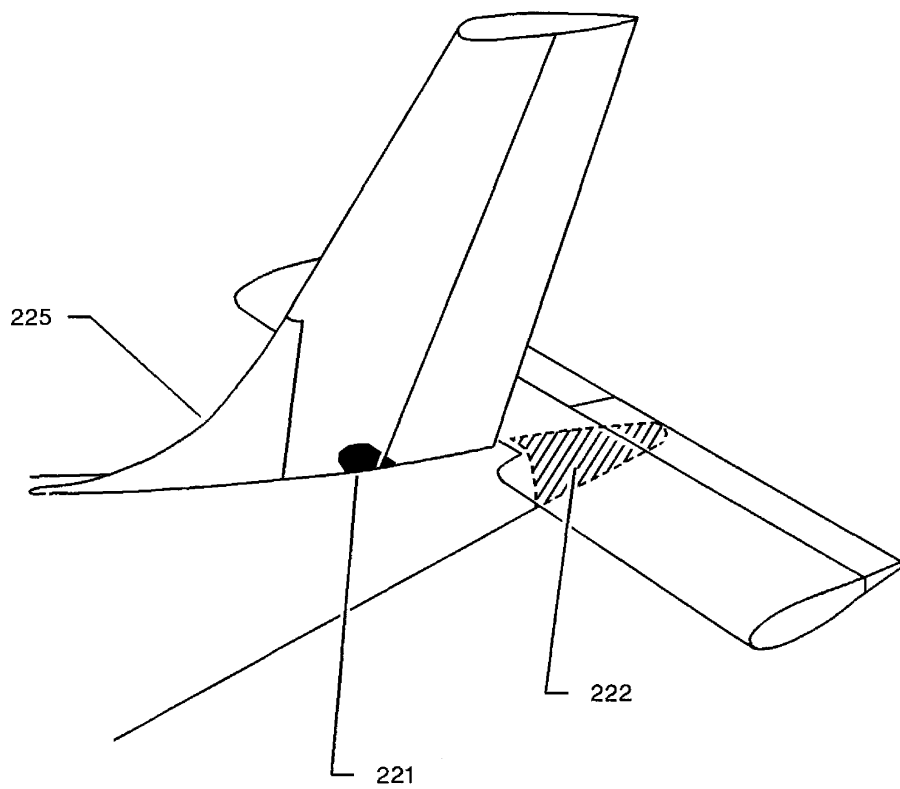

14550000AAAAYZ14200

Inspection doors - Area 220
Figure 3

AFAB
Validity : S / N 1 - 9999 Post-MOD.151

06-30-00 (BM)

Page 7
JUN 02

3) Area 230 - Cockpit (Figure 4)

Identification No.	DESCRIPTION	AREA LOCATION AND ACCESSIBLE ELEMENTS
231L	FWD L.H. side furnishings	Electric circuit routing FWD L.H. NACA water outlet VHF 1 feeder
231R	FWD R.H. side furnishings	Electric circuit routing FWD R.H. NACA water outlet VOR feeder
232L	Circuit-breaker panel	Circuit-breaker and bus bar electric connections FWD L.H. NACA water outlet VHF 1 feeder
232R	Map holder	VOR feeder
233L	L.H. door lower furnishings	L.H. access door locking mechanism Pilot seat belt L.H. FWD lower attachment NACA water outlet and L.H. door mechanism VHF 1 feeder
233R	R.H. door lower furnishings	R.H. access door locking mechanism. Front passenger seat belt R.H. lower FWD attachment NACA water outlet and R.H. door mechanism VOR feeder
234L	L.H. aft furnishings	L.H. FWD seat belt reel Aft lateral seat belt external attachment
234R	R.H. aft furnishings	R.H. FWD seat belt reel Aft lateral seat belt external attachment
235L	L.H. side inspection door	Console lower section Pedals FWD lower air conditioning
235R	R.H. side inspection door	Console lower section Pedals FWD lower air conditioning
236	Tunnel	Aft lower air conditioning Flight control linkage and sealing bellows Ram and static air systems Braking system Aft fuselage and wing electric circuits
237	Mike support plate	Electric connections for micro plugs and head-set
238R	Inspection door	Access to flap indicator printed circuit board (under rear bench seatpan)

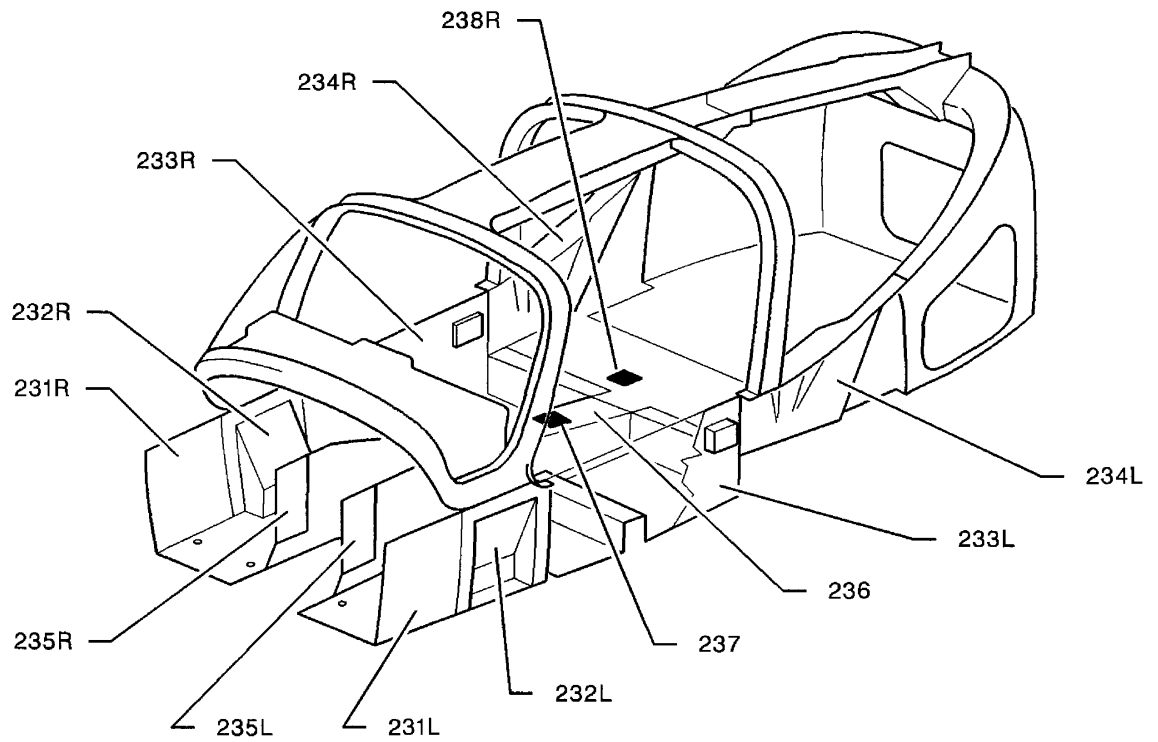

14251600AAAY Z4200

Inspection doors - Area 230
Figure 4

4) Area 240 - Upper duct and baggage compartment (Figure 5)

Identification No.	DESCRIPTION	AREA LOCATION AND ACCESSIBLE ELEMENTS
241A	Aft overhead panel	GPS 2 antenna (if installed)
241F	FWD overhead panel	Upper air conditioning Cabin lighting Emergency lighting Antenna fastenings and feeders on upper duct (if installed) Aural warnings Loud-speaker (if installed)
242	Baggage compartment bottom door	Aft fuselage interior Flight control linkage Autopilot horizontal stabilizer servo-actuators and trim (if installed) Static air system Flashing unit(s) (if installed)
244C	Inspection door (if installed)	ADF 2 antenna (if installed)
249	Cover	Stormscope (if installed) UHF transceiver (if installed)

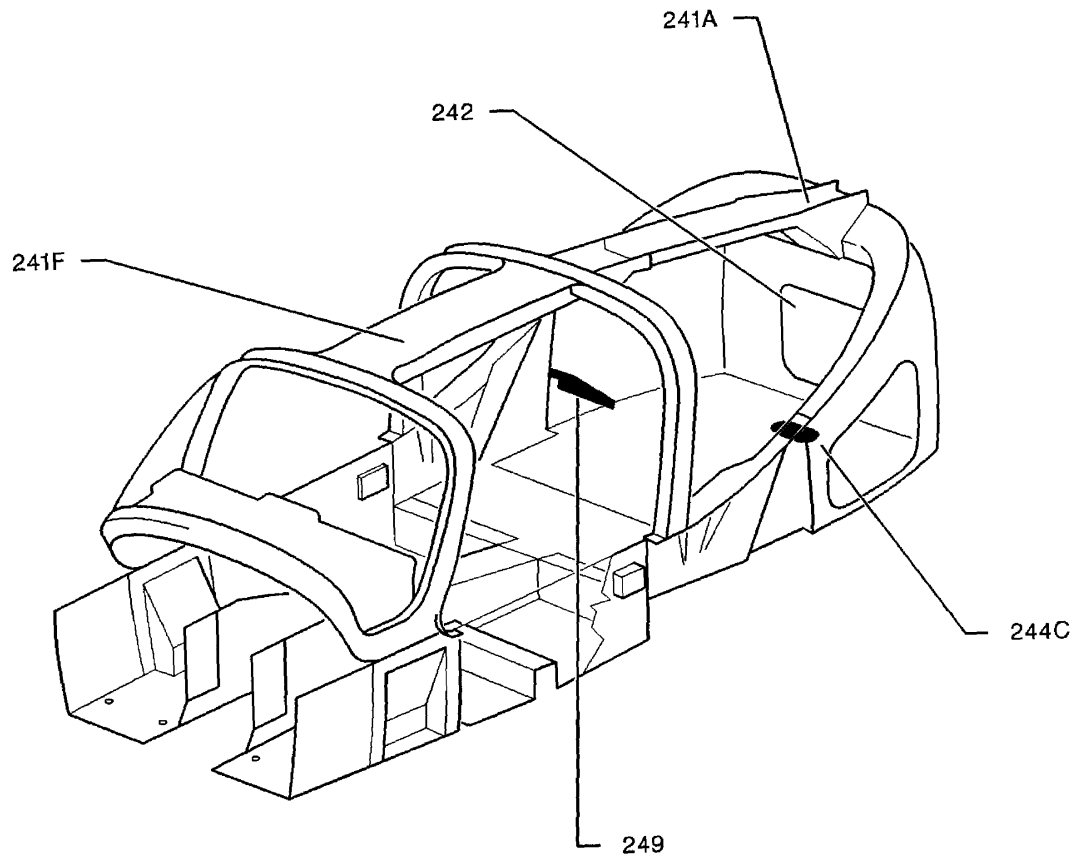

I4251600AAAAYZ24100

Inspection doors - Area 240
Figure 5

5) Area 250 - Main control station (Figure 6)

Identification No.	DESCRIPTION	AREA LOCATION AND ACCESSIBLE ELEMENTS
251C	Central console	Instruments located on central console
251L	L.H. instrument panel	Instruments located on L.H. instrument panel
251R	R.H. instrument panel	Instruments located on R.H. instrument panel
252	Pedestal FWD cover	Wing flap control and pull-off type circuit-breaker electric connections Engine controls Lower air conditioning Flight control linkage Ram air system Brake system Aft fuselage and wing electric circuits
253	Pedestal aft cover	Lighter electric connection Engine controls Lower air conditioning Flight control linkage Fuel selector valve linkage Static and ram air systems Brake system Aft fuselage and wing electric circuits
254L	L.H. panel strip	Pilot air outlet Magneto / start selector Parking brake knob Pressure indicator Emergency static source valve A/P Switch (if installed) Hourmeter (if installed) Stormscope (if installed) Radio Master Switch (if installed)
254R	R.H. panel strip	Front passenger air outlet Air conditioning control Transponder (if installed) Hourmeter (if installed)

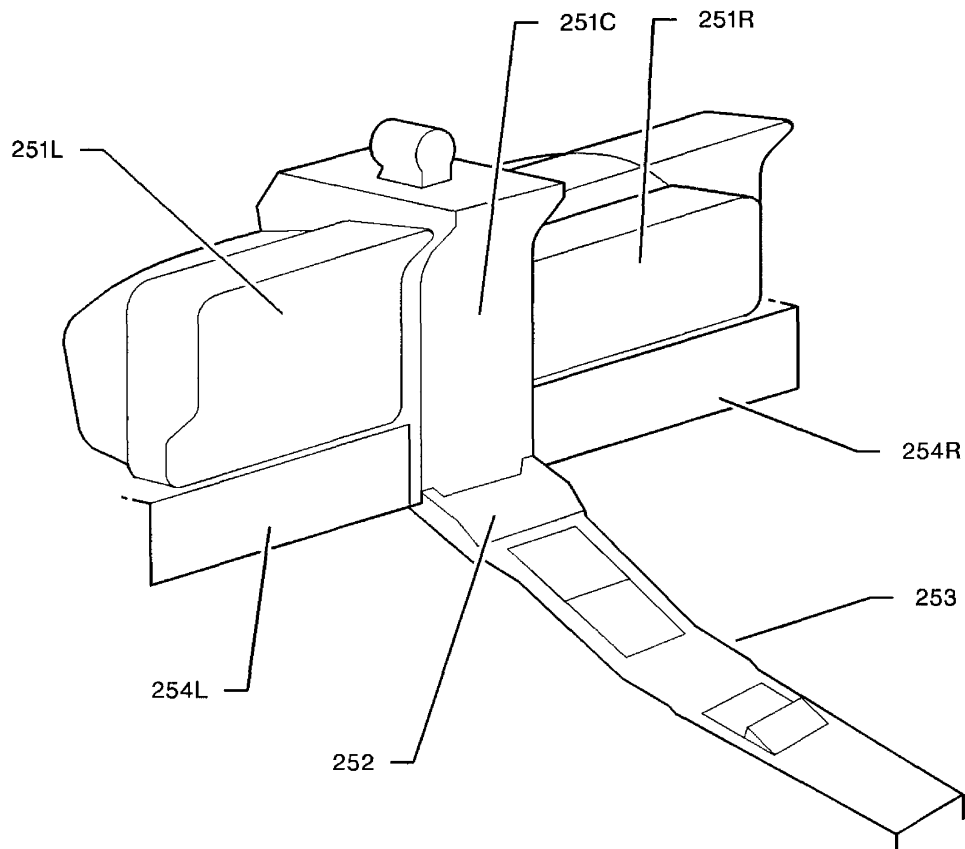

14063000AAAACWZ4000

Inspection doors - Area 250
Figure 6

C. Area 300 - Stabilizers (Figure 7)

Identification No.	DESCRIPTION	AREA LOCATION AND ACCESSIBLE ELEMENTS
311	Vertical stabilizer tip	Antenna access and anti-collision light (if installed)

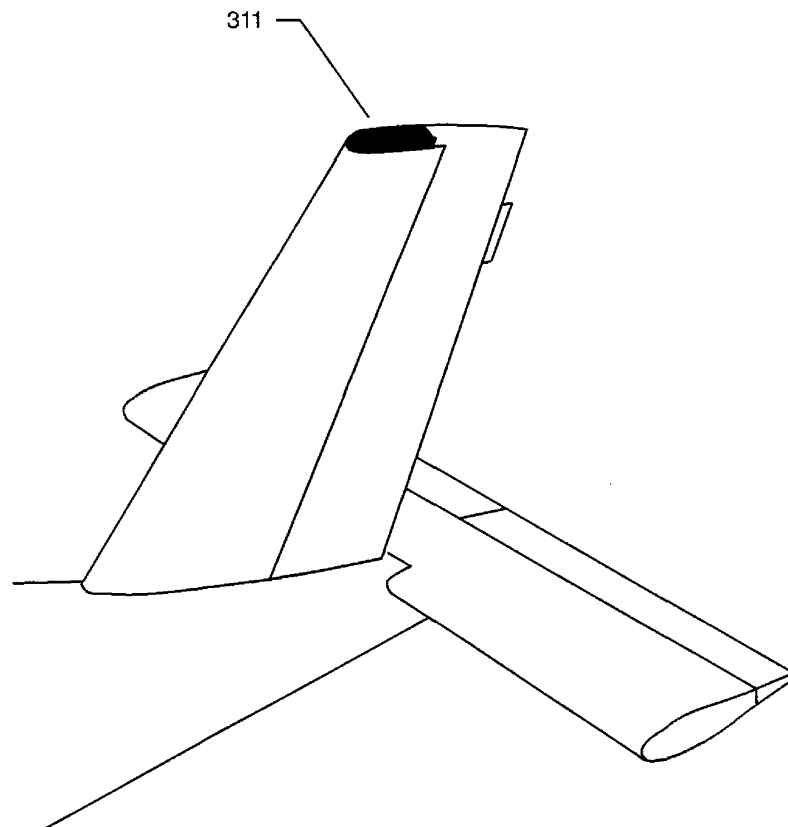

I4550000AAAAAYZ4200

Inspection doors - Area 300
Figure 7

AFAB
Validity : S / N 1 - 9999 Post-MOD.151

06-30-00 (BM)

Page 15
JUN 02

D. Areas 500 / 600 - Wing (Figures 8 and 9)

1) Area 500 - L.H. wing

Identification No.	DESCRIPTION	AREA LOCATION AND ACCESSIBLE ELEMENTS
511	Inspection door	Wing root area in front of spar Spar (FWD side) Aileron linkage Fuel supply lines Fuel strainer (tank outlet)
512	Inspection door	Wing root area behind spar Spar (rear side) Aileron bellcrank Fuel tank air vent (outlet) L.H. main landing gear upper attachment Electric wiring
513	Inspection door	Tank area Capacity gage sensor Low level detector
514	Inspection door	Tank area Capacity gage sensor Air vent (tank interior)
515	Inspection door	Central area behind spar Spar (rear side) Aileron linkage Rigid air vent pipes Capacity gage oscillator
516	Inspection door	End area behind spar Spar (rear side) Aileron bellcrank Aileron control rod Air vent hose
517	Wing tip	Navigation light Anti-collision light Internal end area Light control box (if installed)
518	Inspection door	Wing rear attachment Main landing gear attachment pin
519	Inspection door	Central area behind spar Spar (rear side) Aileron linkage Rigid air vent pipes Wing root gage oscillator

Identification No.	DESCRIPTION	AREA LOCATION AND ACCESSIBLE ELEMENTS
521	Fuel plug	Tank (filling) Fuel gage
522	Light protection	Taxi light Landing light
523	Inspection door	Flux valve if aircraft equipped with radar
531	Inspection door	Fuel tank
5111	Inspection door	Stall warning indicator Spar (FWD side)

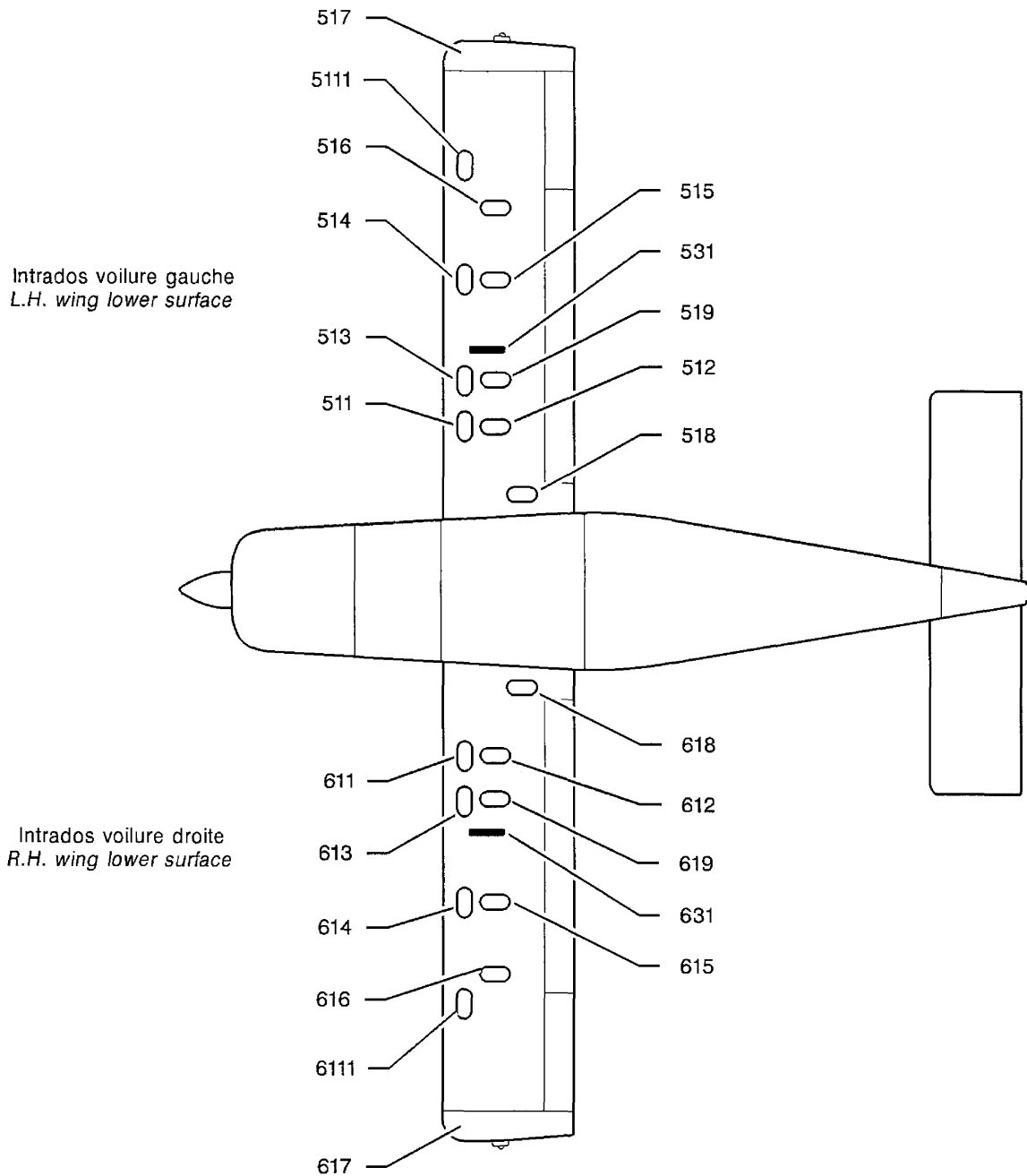

Inspection doors - Areas 500 / 600 - Lower surface and interior
Figure 8

14063000AAAAYZ4201

2) Area 600 - R.H. wing

Identification No.	DESCRIPTION	AREA LOCATION AND ACCESSIBLE ELEMENTS
611	Inspection door	Wing root area in front of spar Spar (FWD side) Aileron linkage Fuel supply line Fuel strainer (tank outlet)
612	Inspection door	Wing root area behind spar Spar (rear side) Aileron bellcrank Fuel tank air vent (outlet) L.H. main landing gear upper attachment Electric wiring
613	Inspection door	Tank area Capacity gage sensor Low level detector
614	Inspection door	Tank area Capacity gage sensor Air vent (tank interior)
615	Inspection door	Center area behind spar Spar (rear side) Aileron linkage Rigid air vent pipe Capacity gage oscillator
616	Inspection door	End area behind spar Spar (rear side) Aileron bellcrank Aileron control rod Air vent hose
617	Wing tip	Navigation light Anti-collision light Internal end area
618	Inspection door	Wing rear attachment Main landing gear attachment pin
619	Inspection door	Center area behind spar Spar (rear side) Aileron linkage Rigid air vent pipe Wing root gage oscillator
621	Fuel plug	Tank (filling) Fuel gage
622	Inspection door	Flux valve (if installed)

Identification No.	DESCRIPTION	AREA LOCATION AND ACCESSIBLE ELEMENTS
631	Inspection door	Fuel tank
6111	Inspection door	Spar (FWD side)

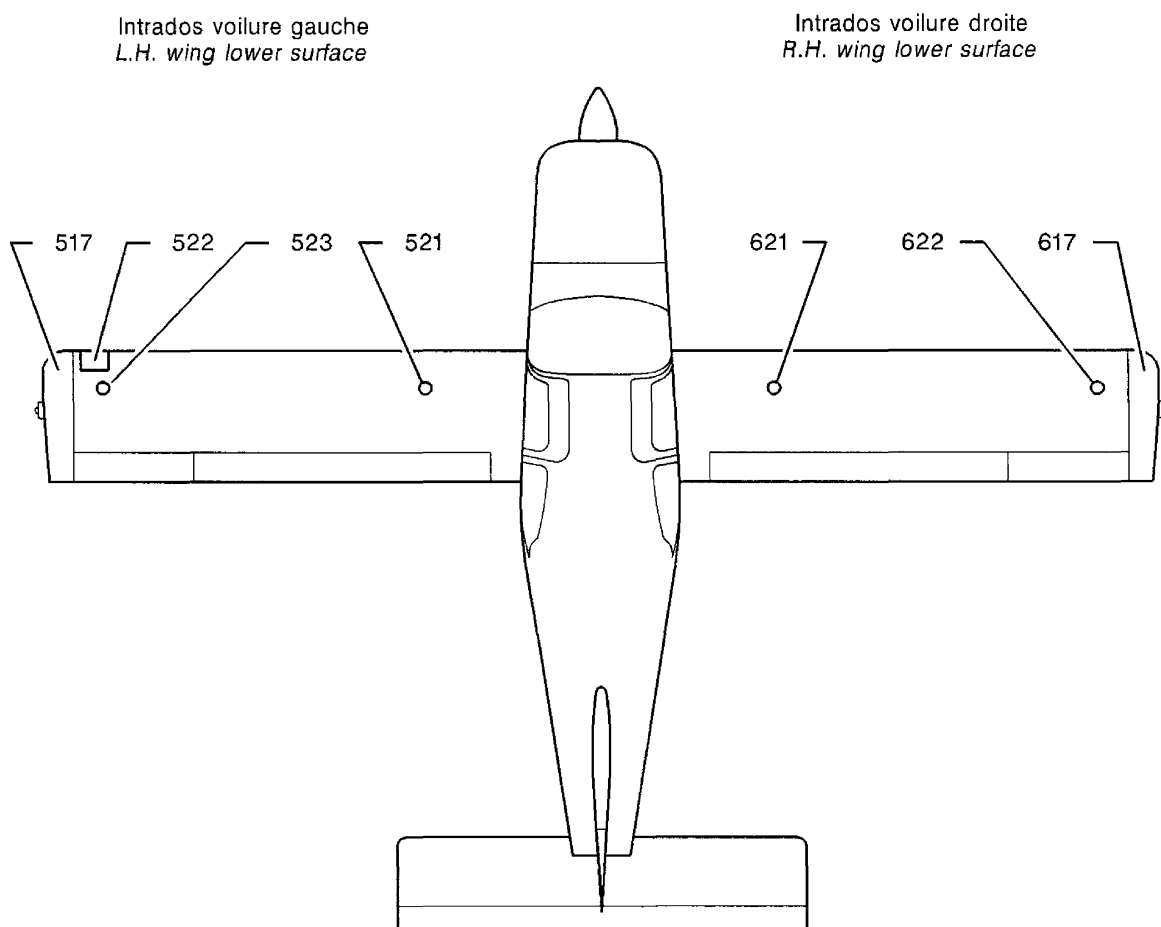

14063000AAAANVZ24100

Inspection doors - Areas 500 / 600 - Upper surface
Figure 9

E. Area 700 - Landing gear

1) Telescopic leg main landing gear (Figure 10)

Identification No.	DESCRIPTION	AREA LOCATION AND ACCESSIBLE ELEMENTS
711	FWD fairing	Nose landing gear lower section and wheel
712	Aft fairing	Nose landing gear lower section and wheel
713	Inspection door	Nose wheel valve
731	Wing / L.H. main landing gear junction cover	L.H main landing gear attachment to wing
732	L.H. main landing gear leg FWD fairing	L.H. main landing gear leg
733	L.H. main landing gear leg aft fairing	L.H. main landing gear leg and brake system
734	L.H. main landing gear wheel fairing	L.H. wheel and axle assy
735	Door	L.H. brake cylinder and disk
736	Door	L.H. wheel valve
741	Wing / R.H. main landing gear junction cover	R.H. main landing gear attachment to wing
742	R.H. main landing gear body FWD fairing	R.H. main landing gear leg
743	R.H. main landing gear body aft fairing	R.H. main landing gear leg and brake system
744	R.H. main landing gear wheel fairing	R.H. wheel and axle assy
745	Door	R.H. brake cylinder and disk
746	Door	R.H. wheel valve

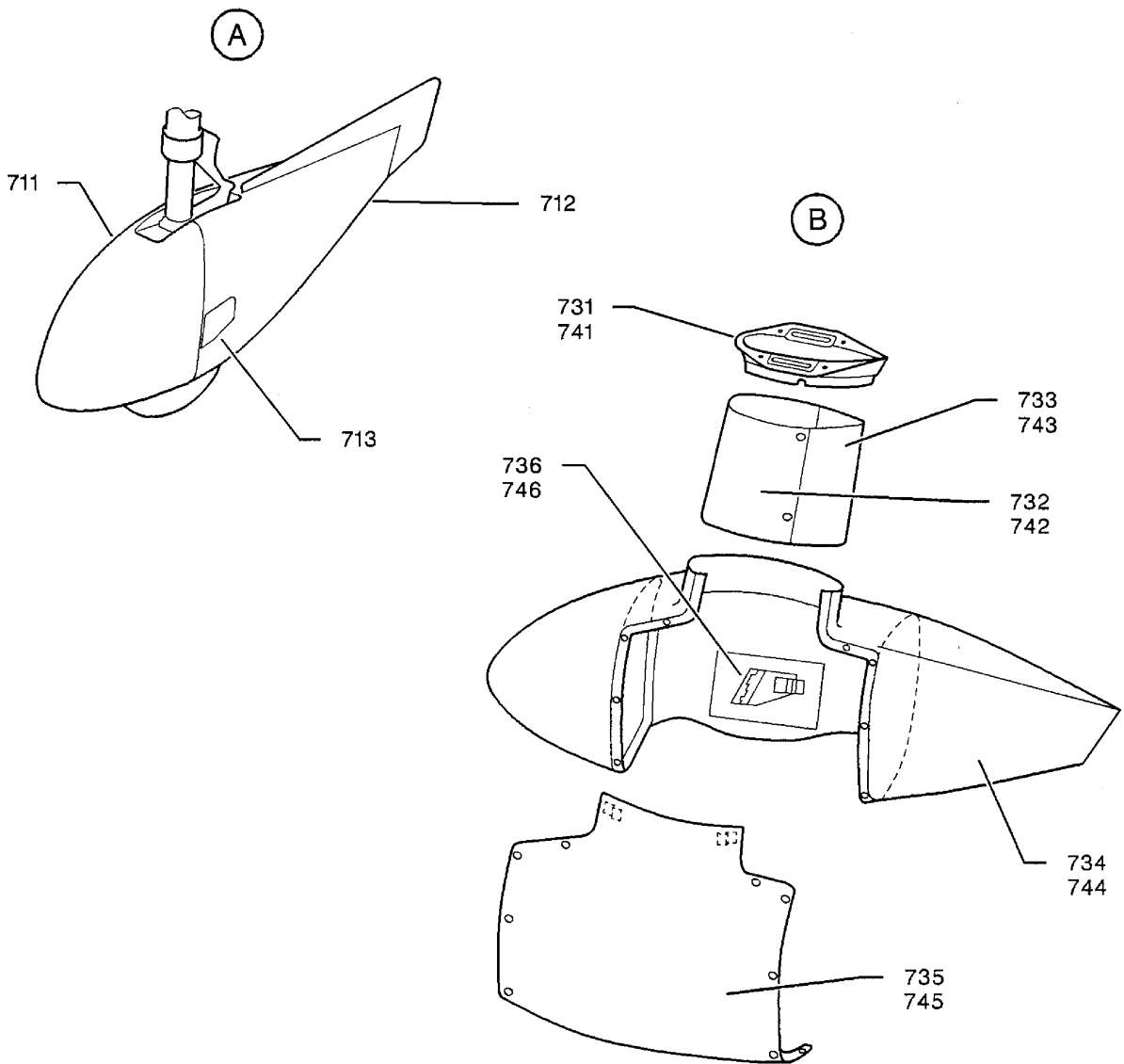
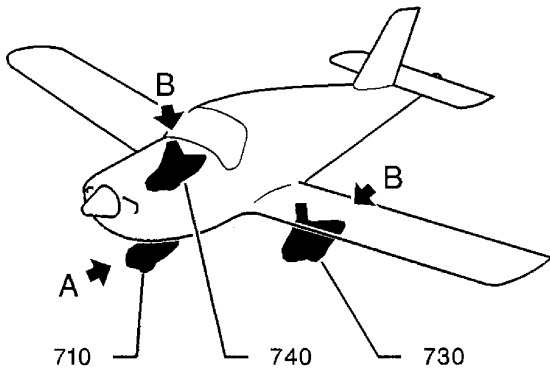

Inspection doors - Area 700
Figure 10

1432100/AAACYZ4000

2) Trailing arm main landing gear (Figure 11)

Identification No.	DESCRIPTION	AREA LOCATION AND ACCESSIBLE ELEMENTS
711	FWD fairing	Nose landing gear lower section and wheel
712	Aft fairing	Nose landing gear lower section and wheel
713	Inspection door	Nose wheel valve
734	L.H. inboard half-fairing	L.H. wheel and axle assy
735	L.H. outboard half-fairing	L.H. brake cylinder and disk
736	Inspection door	L.H. wheel valve
744	R.H. inboard half-fairing	R.H. wheel and axle assy
745	R.H. outboard half-fairing	R.H. brake cylinder and disk
746	Inspection door	R.H. wheel valve

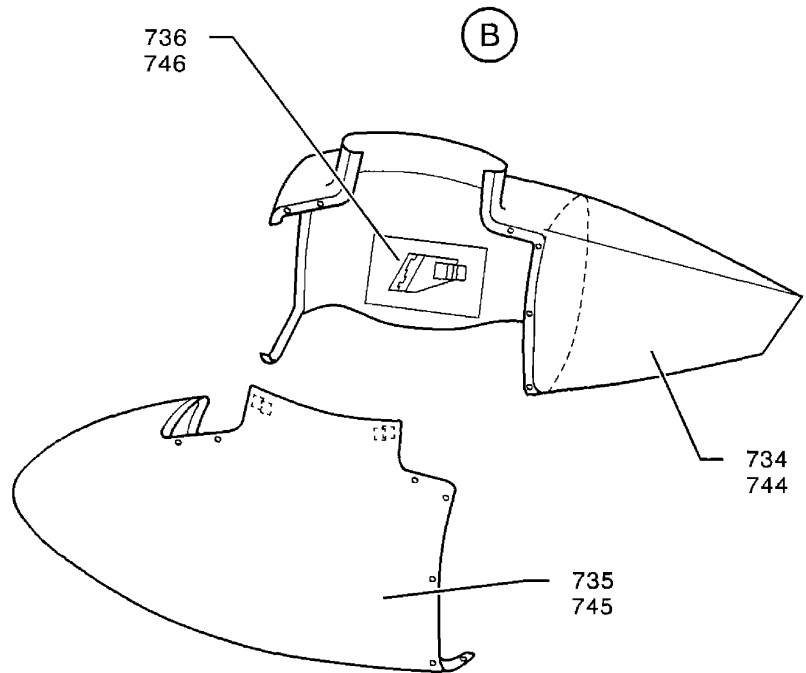
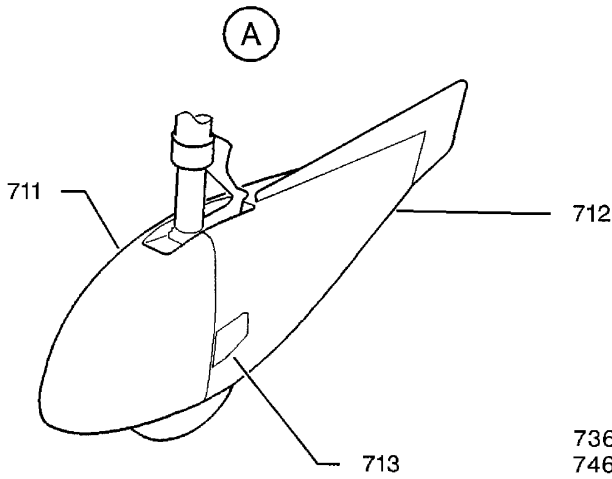
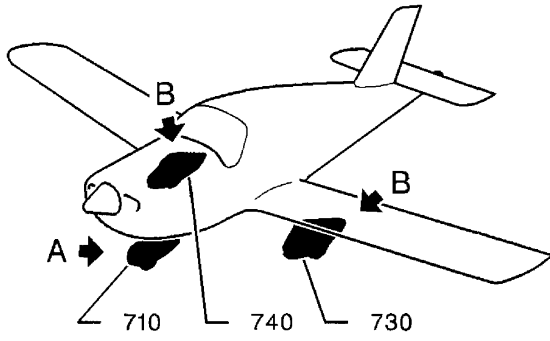

Inspection doors - Area 700
Figure 11

143210244AAAUVZ4100

PAGE INTENTIONALLY LEFT BLANK