

# MAINTENANCE MANUAL

(LINE MAINTENANCE) FOR ROTAX<sup>®</sup> ENGINE TYPE 912 SERIES

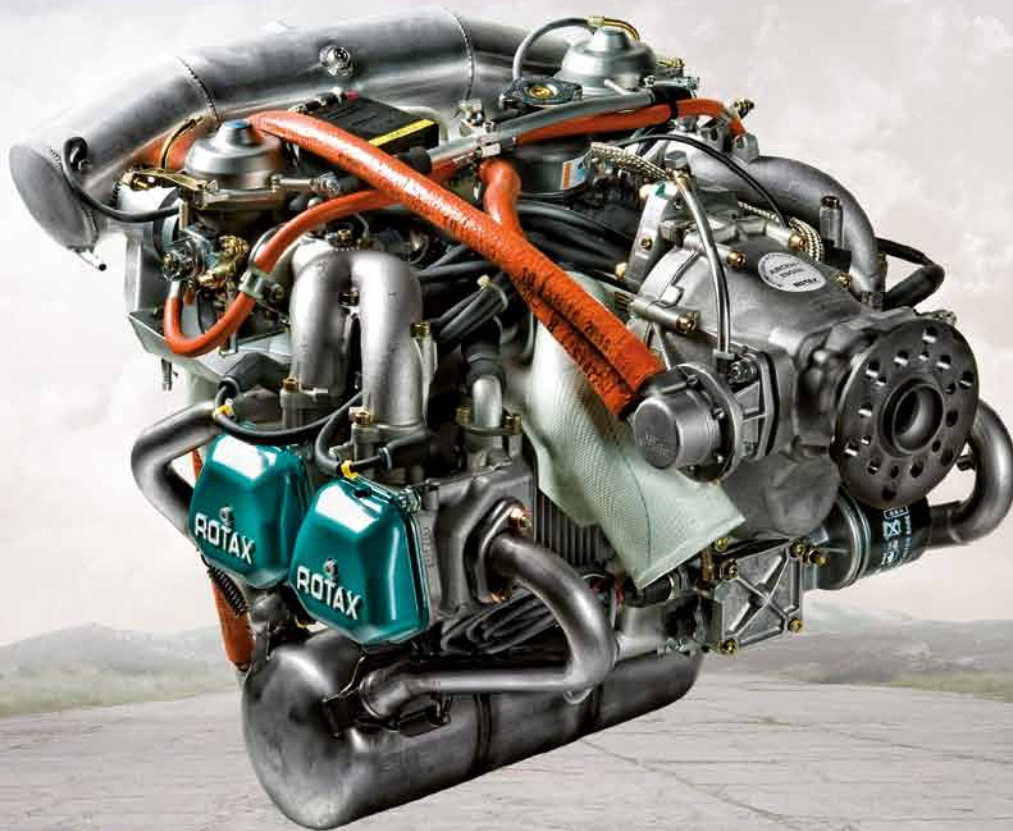

 **WARNING**

**Before starting any maintenance work, please read the Maintenance Manual, as it contains important safety relevant information. Failure to do so may result in personal injuries including death. Consult the original equipment manufacturer's handbook for additional instructions!**

These technical data and the information embodied therein are the property of BRP-Powertrain GmbH&Co KG, Austria, acc, BGBl 1984 no. 448, and shall not, without prior written permission of BRP-Powertrain GmbH&Co KG, be disclosed in whole or in part to third parties. This legend shall be included on any reproduction of these data, in whole or in part.

Copyright 2013 © - all rights reserved.

ROTAX<sup>®</sup> is a trade mark of BRP-Powertrain GmbH&Co KG. In the following document the short form of BRP-Powertrain GmbH&Co KG = BRP-Powertrain is used.

Other product names in this documentation are used purely for ease of identification and may be trademarks of the respective company or owner.

Approval of translation has been done to best knowledge and judgement - in any case the original text in german language is authoritative.

**BRP-Powertrain**  
MAINTENANCE MANUAL

**Chapter: INTRO**  
**GENERAL NOTE**

**Foreword**

Before carrying out maintenance work on the engine, read the Maintenance Manual (Line Maintenance) carefully.

If any passages of the Manual are not clearly understood or if you have questions, please contact an authorized Distribution or Service Center for ROTAX-aircraft engines.

**Chapter structure**

The structure of the Manual follows whenever it is applicable the structure of the ATA (Air Transport Association) standards. The aim is the compatibility with the aircraft manufacturer documentation, i.e. they must adapt these documentation to their standard.

The Maintenance Manual is subdivided into the following chapters:

Subject	Chapter
Introduction	Chapter <a href="#">INTRO</a>
List of effective pages	Chapter <a href="#">LEP</a>
Table of amendments	Chapter <a href="#">TOA</a>
General note	Chapter <a href="#">00-00-00</a>
Airworthiness limitations	Chapter <a href="#">04-00-00</a>
Maintenance	Chapter <a href="#">05-00-00</a>
Time limits	Chapter <a href="#">05-10-00</a>
Scheduled maintenance checks	Chapter <a href="#">05-20-00</a>
Unscheduled maintenance checks	Chapter <a href="#">05-50-00</a>
Maintenance of the systems	Chapter <a href="#">12-00-00</a>
Replenishing operating fluids	Chapter <a href="#">12-10-00</a>
Scheduled maintenance	Chapter <a href="#">12-20-00</a>

d05550.fm

**BRP-Powertrain**  
MAINTENANCE MANUAL

NOTES

**BRP-Powertrain**  
MAINTENANCE MANUAL

**Chapter: LEP**  
**LIST OF EFFECTIVE PAGES**

chapter	page	date	chapter	page	date	
INTRO	Title page		05-10-00	3	09 01 2012	
	1	09 01 2012		4	09 01 2012	
	2	09 01 2012		5	09 01 2012	
LEP	1	01 01 2013		6	01 01 2013	
	2	01 01 2013		7	01 01 2013	
TOA	1	01 01 2013		8	09 01 2012	
	2	09 01 2012		05-20-00	1	09 01 2012
	3	01 01 2013			2	09 01 2012
	4	09 01 2012	3		09 01 2012	
00-00-00	1	09 01 2012	4		09 01 2012	
	2	09 01 2012	5		09 01 2012	
	3	09 01 2012	6		09 01 2012	
	4	09 01 2012	7		09 01 2012	
	5	09 01 2012	8		09 01 2012	
	6	09 01 2012	9		09 01 2012	
	7	09 01 2012	10		09 01 2012	
	8	09 01 2012	11		01 01 2013	
	9	09 01 2012	12		01 01 2013	
	10	09 01 2012	13		01 01 2013	
	11	09 01 2012	14		01 01 2013	
	12	09 01 2012	15		01 01 2013	
	13	09 01 2012	16		01 01 2013	
	14	09 01 2012	17		01 01 2013	
	15	09 01 2012	18		01 01 2013	
	16	09 01 2012	05-50-00	1	01 01 2013	
04-00-00	1	09 01 2012		2	09 01 2012	
	2	09 01 2012		3	01 01 2013	
05-00-00	1	09 01 2012		4	01 01 2013	
	2	09 01 2012		5	09 01 2012	
	3	09 01 2012		6	09 01 2012	
	4	09 01 2012		7	09 01 2012	
	5	09 01 2012		8	09 01 2012	
	6	09 01 2012		9	01 01 2013	
	7	09 01 2012		10	09 01 2012	
	8	09 01 2012		11	01 01 2013	
	9	09 01 2012		12	01 01 2013	
	10	09 01 2012	13	01 01 2013		
	11	09 01 2012	14	01 01 2013		
	12	09 01 2012	15	01 01 2013		
05-10-00	1	09 01 2012	16	01 01 2013		
	2	09 01 2012	17	01 01 2013		
			18	01 01 2013		
			19	01 01 2013		
			20	01 01 2013		

d05551.fm

**BRP-Powertrain**  
**MAINTENANCE MANUAL**

chapter	page	date
05-50-00	21	01 01 2013
	22	01 01 2013
	23	01 01 2013
	24	01 01 2013
	25	09 01 2012
	26	09 01 2012
12-00-00	1	01 01 2013
	2	01 01 2013
12-10-00	1	09 01 2012
	2	09 01 2012
	3	09 01 2012
	4	09 01 2012
	5	09 01 2012
	6	09 01 2012
	7	09 01 2012
	8	09 01 2012
	9	09 01 2012
	10	09 01 2012
	11	09 01 2012
	12	09 01 2012
12-20-00	1	01 01 2013
	2	09 01 2012
	3	09 01 2012
	4	09 01 2012
	5	01 01 2013
	6	09 01 2012
	7	01 01 2013
	8	09 01 2012
	9	01 01 2013
	10	09 01 2012
	11	01 01 2013
	12	01 01 2013
	13	09 01 2012
	14	09 01 2012
	15	01 01 2013
	16	09 01 2012
	17	09 01 2012
	18	09 01 2012
	19	09 01 2012
	20	09 01 2012
	21	09 01 2012
	22	09 01 2012
	23	09 01 2012
	24	01 01 2013
	25	01 01 2013
	26	09 01 2012
	27	09 01 2012

chapter	page	date
	28	09 01 2012
	29	09 01 2012
	30	09 01 2012
	31	09 01 2012
	32	01 01 2013
	33	09 01 2012
	34	09 01 2012
	35	09 01 2012
	36	09 01 2012
	37	09 01 2012
	38	09 01 2012
	39	09 01 2012
	40	09 01 2012
	41	09 01 2012
	42	09 01 2012
	43	09 01 2012
	44	09 01 2012
	45	09 01 2012
	46	09 01 2012
	47	09 01 2012
	48	09 01 2012
	49	01 01 2013
	50	09 01 2012
	51	09 01 2012
	52	01 01 2013
	53	09 01 2012
	54	01 01 2013
	55	09 01 2012
	56	01 01 2013
	57	09 01 2012
	58	09 01 2012
	59	09 01 2012
	60	01 01 2013
	61	09 01 2012
	62	09 01 2012
	63	09 01 2012
	64	09 01 2012
	65	09 01 2012
	66	09 01 2012
	67	09 01 2012
	68	01 01 2013
	Rear page	

d05551.fm

**BRP-Powertrain**  
**MAINTENANCE MANUAL**

**Chapter: TOA**  
**TABLE OF AMENDMENTS**

**Approval\***

The technical content of this document is approved  
under the authority DOA ref. EASA.21J.048

Note: THE APPROVAL IS GIVEN TO ALL CHAPTERS  
EXCEPT THE AIRWORTHINESS LIMITATIONS  
SECTION 04-00-00 WHICH IS SUBJECT TO  
SPECIFIC APPROVAL OF THE EASA.

no.	chapter	page	date of change	remark for approval	date of approval from authorities	date of issue	signature
0	INTRO	all	09 01 2012	DOA*			
0	LEP	all	09 01 2012	DOA*			
0	TOA	all	09 01 2012	DOA*			
0	00-00-00	all	09 01 2012	DOA*			
0	04-00-00	1	09 01 2012	EASA approved			
0	05-00-00	all	09 01 2012	DOA*			
0	05-10-00	all	09 01 2012	DOA*			
0	05-20-00	all	09 01 2012	DOA*			
0	05-50-00	all	09 01 2012	DOA*			
0	12-00-00	all	09 01 2012	DOA*			
0	12-10-00	all	09 01 2012	DOA*			
0	12-20-00	all	09 01 2012	DOA*			
1	LEP	all	01 01 2013	DOA*			
1	TOA	1, 3	01 01 2013	DOA*			
1	05-10-00	6,7	01 01 2013	DOA*			
1	05-20-00	11-18	01 01 2013	DOA*			
1	05-50-00	1,3,4,9	01 01 2013	DOA*			
		11-24	01 01 2013	DOA*			
1	12-20-00	1,5,7,9,11,	01 01 2013	DOA*			
		12,15,24	01 01 2013	DOA*			
		25,32,49,	01 01 2013	DOA*			
		52,54,56,	01 01 2013	DOA*			
		60,68	01 01 2013	DOA*			

d05552.fm

**BRP-Powertrain**  
MAINTENANCE MANUAL

NOTES

d05552.fm

**BRP-Powertrain**  
MAINTENANCE MANUAL

**Chapter: TOA**  
**SUMMARY OF AMENDMENTS**

**Content**

Summary of the relevant amendments in this context, but makes no claim to completeness.

Current No.	chapter	page	date of change	Comment
0	all	all	09 01 2012	New Edition.
0	05-00-00	5	09 01 2012	Valid time.
0	05-10-00	5, 8	09 01 2012	Storage period of engine, Time limit for fuel pump.
0	05-20-00	17	09 01 2012	Smooth performance of the engine
0	12-20-00	22, 49	09 01 2012	Inspect rotary seal for leakage, compressed air
1	05-10-00	6,7	01 01 2013	Footnote number changed.
1	05-20-00	11	01 01 2013	Change of text.
		12	01 01 2013	Change of 600 hr.
		13	01 01 2013	Change of reference.
		14	01 01 2013	Compression check changed to every 200 hr.
		14	01 01 2013	Carburetor synchronization changed to mech. and pneumatic synchronization.
		15	01 01 2013	Float chamber assy. check changed to every 200 hr.
		16	01 01 2013	Checking the propeller gearbox: footnotes added.
		16	01 01 2013	Oil change: footnote added, reference changed.
		16	01 01 2013	Check the oil tank: changed to every 200 hr.
		17	01 01 2013	Engine test run: Reference added.
		18	01 01 2013	Change of text.
1	05-50-00	1	01 01 2013	Change of text.
		3	01 01 2013	Chapt. 1.1: change of text.
		4	01 01 2013	Chapt. 1.2: change of text.
		9	01 01 2013	Chapt. 3.1: change of text.
		11	01 01 2013	Chapt. 3.4: change of text.
		12-23	01 01 2013	Change of chapter number.
		13	01 01 2013	Cylinder head temperature instead of coolant temperature.
1	12-20-00	1,5,7	01 01 2013	Change of text.
		9	01 01 2013	Text deleted.
		11	01 01 2013	Change of text.
		12	01 01 2013	Change of text.
		15	01 01 2013	Text deleted.
		24,25	01 01 2013	Graphic reference added. page 25 step 3 added.
		32	01 01 2013	Change of text.
		49	01 01 2013	Change of text.
		52	01 01 2013	Change of text. possible foreign matter added
		54	01 01 2013	Change of text.
		56	01 01 2013	Change of text.
		60	01 01 2013	Text deleted.
		68	01 01 2013	Checking the friction torque: formular added.

d05552.fm

**BRP-Powertrain**  
MAINTENANCE MANUAL

NOTES

d05552.fm

**BRP-Powertrain**  
MAINTENANCE MANUAL

**Chapter: 00-00-00**

**GENERAL NOTE**

**Introduction** This section describes this maintenance of engine type ROTAX 912 Series.

**NOTES:** The ROTAX 912 Series includes all engines such as the 912 A, 912 F, 912 S, 912 UL, 912 ULS and 912 ULSFR.

**Table of contents** This chapter of the Maintenance Manual contains general and safety information concerning the operation of the aircraft engine.

Subject	Page
General note	page 3
Abbreviations and terms used in this Manual	page 5
Conversion table	page 8
Safety notice	page 9
Safety information	page 10
Instruction	page 12
Maintenance Concept	page 13
Technical documentation	page 14
Use for intended purpose	page 16

**BRP-Powertrain**  
MAINTENANCE MANUAL

NOTES

*d05553.fm*

**BRP-Powertrain**  
MAINTENANCE MANUAL

**1) General note**

<b>Purpose</b>	The purpose of this Maintenance Manual is to acquaint maintenance service staff (iRMT) approved by the local aviation authorities with some basic maintenance and safety information for service work.
<hr/>	
<b>Documentation</b>	For more detailed information regarding, maintenance, safety- or flight operation, consult the documentation provided by the aircraft manufacturer and/or dealer.  For additional information on engines, maintenance or parts, you can also contact your nearest authorized ROTAX-aircraft engine distributor.
<hr/>	
<b>ROTAX Distributors</b>	ROTAX Authorized Distributors for Aircraft Engines see latest Operators Manual or on the Internet at the official Website <a href="http://www.FLYROTAX.com">www.FLYROTAX.com</a> .
<hr/>	
<b>Engine serial number</b>	When making inquiries or ordering parts, always indicate the engine serial number, as the manufacturer makes modifications to the engine for product improvement. The engine number (1) is on the ignition cover, on the left, opposite the electric starter. See Fig. 1.

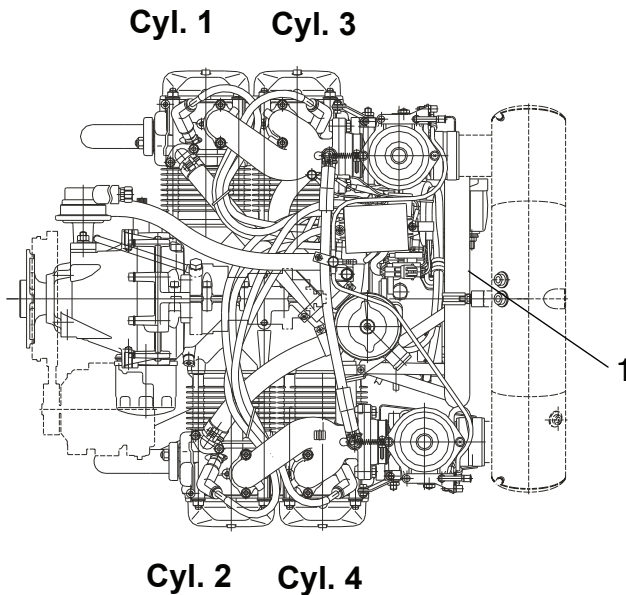

*Fig. 1*

07902

d05553.fm

**BRP-Powertrain**  
MAINTENANCE MANUAL



NOTES

*d05553.fm*

**BRP-Powertrain**  
MAINTENANCE MANUAL

## 2) Abbreviations and terms used in this Manual

### Abbreviations

Abbreviation	Description
*	Reference to another section
	center of gravity
	The drop symbol indicates use of sealing agents, adhesives or lubricants. (only in the Illustrated Parts Catalog)
°C	Degrees Celsius (Centigrade)
°F	Degrees Fahrenheit
rpm	Revolutions per minute
912 A	see OM (Type designation)
912 F	see OM (Type designation)
912 S	see OM (Type designation)
912 UL	see OM (Type designation)
912 ULS	see OM (Type designation)
914 F	see OM (Type designation)
914 UL	see OM (Type designation)
A	Ampere
Ah	Ampere hour
A/C	Aircraft
A/F	Across-flat dimension
ASB	Alert Service Bulletin
ACG	Austro Control GmbH
API	American Petrol Institute
ASTM	American Society for Testing and Materials
ATA	Air Transport Association
CAN/CGSB	Canadian General Standards Board
CSA	Constant Speed Actuator
CW	Clockwise
CCW	Counter-clockwise
DCDI	Dual Capacitor Discharge Ignition
DOT	Department of Transport
DOA	Design Organisation Approval
EASA	European Aviation Safety Agency
IM	Installation Manual
ECU	Engine Control Unit
EGT	Exhaust Gas Temperature
INTRO	Introduction
EMS	Engine Management System

d05553.fm

**BRP-Powertrain**  
**MAINTENANCE MANUAL**

Abbreviation	Description
EN	European Norm
IPC	Illustrated Parts Catalog
FAA	Federal Aviation Administration
FAR	Federal Aviation Regulation
OM	Overhaul Manual
hr.	hours
OM	Operators Manual
IFR	Instrument Flight Rules
iRMT	independent ROTAX Maintenance Technician
TOC	Table of Contents
ISA	International Standard Atmosphere
kg	kilograms
AD	Airworthiness Directive
MS	magneto side
MON	motor octane number
N	new part (only Illustrated Parts Catalog)
nB	as necessary (only Illustrated Parts Catalog)
n.a.	not available
NDT	non-destructive testing
Nm	newton meter
POA	Production Organisation Approval
PSU	power supply unit
PTO	Power Take Off
Rev.	Revision
ROTAX	is a trade mark of BRP-Powertrain GmbH & Co KG
RON	Research Octane Number
RV	Record of Revisions
s.v.	still valid (only IPC)
S/N	Serial Number
SB	Service Bulletin
SI	Service Instruction
SL	Service Letter
SMD	Surface Mounted Devices
TBO	Time Between Overhaul
TC	Type Certificate
part no.	Part number
TSNP	Time Since New Part
TSO	Time Since Overhaul

d05553.fm

**BRP-Powertrain**  
MAINTENANCE MANUAL

Abbreviation	Description
V	Volt
VFR	Visual Flight Rules
LEP	List of Effective Pages
W	Watt
MM	Maintenance Manual
XXX	shows the serial component number

d05553.fm

**BRP-Powertrain**  
MAINTENANCE MANUAL

**2.1) Conversion table**

<p><b>Units of length:</b>  1 mm = 0.03937 in  1 in = 25.4 mm  1 ft = 12 in  = 0.3048 m</p>	<p><b>Units of power:</b>  1 kW = 1.341 hp  1 hp = 0.7457 kW  1 kW = 1.3596 PS  1 PS = 0.7355 kW</p>																				
<p><b>Units of area:</b>  1 cm<sup>2</sup> = 0.155 sq in (in<sup>2</sup>)  1 sq in (in<sup>2</sup>) = 6.4516 cm<sup>2</sup></p>	<p><b>Units of temperature:</b>  K = °C - 273,15  °C = (°F - 32) / 1,8  °F = (°C x 1.8) + 32</p>																				
<p><b>Units of volume:</b>  1 cm<sup>3</sup> = 0.06102 cu in (in<sup>3</sup>)  1 cu in (in<sup>3</sup>) = 16.3871 cm<sup>3</sup> (in<sup>3</sup>)  1 dm<sup>3</sup> = 1 l  1 dm<sup>3</sup> = 0.21997 gal (UK)  1 gal (UK) = 4.5461 dm<sup>3</sup>  1 dm<sup>3</sup> = 0.26417 gal (US)  1 gal (US) = 3.7854 dm<sup>3</sup></p>	<p><b>Units of velocity:</b>  1 m/s = 3.6 km/h  1 ft/min = 0.3048 m/min  = 0.00508 m/sec  1 m/s = 196.85 ft/min  1 kt = 1.852 km/h  1 km/h = 0.53996 kn</p>																				
<p><b>Units of mass:</b>  1 kg = 2.2046 lb  1 lb = 0.45359 kg</p>	<p><b>spec. fuel consumption:</b>  1 g/kWh = 0.001644 lb/hph  1 lb/hph = 608.277 g/kWh</p>																				
<p><b>Density:</b>  1 g/cm<sup>3</sup> = 0.016018 lb/ft<sup>3</sup>  1 lb/ft<sup>3</sup> = 62.43 g/cm<sup>3</sup></p>	<p><b>Units of torque:</b>  1 Nm = 0.737 ft lb  = 8.848 in lb  1 ft lb = 1.356 Nm  1 in lb = 0.113 Nm</p>																				
<p><b>Units of force:</b>  1 N = 0.224809 lbf  1 lbf = 4.4482 N</p>	<p><b>Cable cross-section:</b>  <b>Conversion table - Wire Gauge:</b>  <b>AWG-mm<sup>2</sup></b></p> <table border="1" style="width: 100%; border-collapse: collapse; text-align: center;"> <tr> <td>AWG</td> <td>4</td> <td>6</td> <td>8</td> <td>10</td> <td>12</td> <td>14</td> <td>16</td> <td>18</td> <td>20</td> </tr> <tr> <td>mm<sup>2</sup></td> <td>21</td> <td>13</td> <td>8.4</td> <td>5.3</td> <td>3.3</td> <td>2.1</td> <td>1.3</td> <td>0.8</td> <td>0.52</td> </tr> </table>	AWG	4	6	8	10	12	14	16	18	20	mm <sup>2</sup>	21	13	8.4	5.3	3.3	2.1	1.3	0.8	0.52
AWG	4	6	8	10	12	14	16	18	20												
mm <sup>2</sup>	21	13	8.4	5.3	3.3	2.1	1.3	0.8	0.52												
<p><b>Units of pressure:</b>  1 Pa = 1N/m<sup>2</sup>  1 bar = 100 000 Pa/1000 hPa/  100 kPa  1 bar = 14.5037 lbf/in<sup>2</sup> (psi)  1 lbf/in<sup>2</sup> (psi) = 0.0689 bar  1 in Hg = 33.8638 hPa</p>																					

d05553.fm

**BRP-Powertrain**  
MAINTENANCE MANUAL

### 3) Safety notice

**General note** Although the reading of such information does not eliminate the hazard, understanding the information will promote its correct use. Always use common workshop safety practice.

The information and components-/system descriptions contained in this Manual are correct at the time of publication. BRP-Powertrain maintains a policy of continuous improvement of its products without imposing upon itself any obligation to install them on its products previously manufactured.

---

**Revision** BRP-Powertrain reserves the right at any time, and without incurring obligation, to remove, replace or discontinue any design, specification, feature or otherwise.

---

**Measure** Specifications are given in the SI metric system with the USA equivalent in parenthesis.

---

**Symbols used** This Manual uses the following symbols to emphasize particular information. This information is important and must be observed.



**WARNING**

Identifies an instruction which, if not followed, may cause serious injury including the possibility of death.



**CAUTION**

Identifies an instruction which, if not followed, may cause minor or moderate injury.

**NOTICE**

Denotes an instruction which, if not followed, may severely damage the engine or other component.

**NOTES:** Indicates supplementary information which may be needed to fully complete or understand an instruction.

**ENVIRONMENTAL NOTE**

Environment note gives you tips and behaviors to environmental protection.



A revision bar outside of the page margin indicates a change to text or graphic.

d05553.fm

**BRP-Powertrain**  
MAINTENANCE MANUAL

### 3.1) Safety notice

<b>General note</b>	<p>This information relates to the preparation and use of ROTAX aircraft engines and has been utilized safely and effectively by BRP-Powertrain. However, BRP-Powertrain disclaims liability for all damage and/or injuries resulting from the improper use of the contents. BRP-Powertrain requires that any service be carried out and verified by a technician that has a current iRMT reating. See chap. 05-00-00 section 1.2)</p> <hr/>
<b>Manual</b>	<p>This Manual has been prepared as a guide to correctly service and maintain all ROTAX 912 aircraft engines.</p> <p>This edition was primarily published to be used by aircraft mechanics who are already familiar with all service procedures relating to ROTAX aircraft engines.</p> <p>This Manual uses technical terms which may be slightly different from the ones used in the Illustrated Parts Catalog.</p> <p>It is understood that this Manual may be translated into another language. In the event of any discrepancy the German version prevails.</p> <hr/>
<b>Warning</b>	<p>It is your responsibility to be completely familiar with the safety instructions including warnings and cautions described in this Manual. These warnings and cautions advise of specific operating and servicing methods that, if not observed, can cause a serious engine malfunction or cause the engine to lose power in flight which can result in loss of life, injury or damage to equipment.</p> <p>It is, however, important to understand that these warnings and cautions are not exhaustive. BRP-Powertrain could not possibly know, evaluate and advise the user of all conceivable ways in which service might be done or of the possible hazardous consequences of each way.</p> <hr/>
<b>Safety instruction</b>	<p>In addition to observing the instructions in our Manual, general safety and accident preventative measures, legal regulations and regulations of any aeronautical authority must be observed.</p> <p>Where differences exist between this Manual and regulations provided by any authority, the more stringent regulation should be applied.</p> <hr/>
<b>Illustration</b>	<p>The content depicts parts and/or procedures applicable to the particular product at its time of manufacture. It does not include dealer modifications, whether authorized or not by BRP-Powertrain, after manufacturing the product.</p> <hr/>

d05553.fm

**BRP-Powertrain**  
MAINTENANCE MANUAL

**Locking devices** Locking devices (e.g. locking tab, self-locking fasteners, etc.) must be installed or replaced with new ones, where specified. If the efficiency of a locking device is impaired, it must be replaced.

---

**Torque wrench tightening**

**NOTICE**

If not specified otherwise, the threads are not lubricated when fastened.

Torque wrench tightening specifications must be strictly adhered to.

---

### 3.2) Instruction

<b>General note</b>	<p>Engines require instructions regarding their application, use, operation, maintenance and repair.</p> <p>Technical documentation and directions are useful and necessary complementary elements for personal instruction, but can by no means substitute theoretical and practical instructions.</p> <p>These instructions should cover explanation of the technical context, advice for operation, maintenance, use and operational safety of the engine.</p>
<b>Safety notice</b>	<p>In this technical Manual passages concerning safety are especially marked. Pass on safety warnings to other users!</p>
<b>Accessories</b>	<p>This engine must only be operated with accessories supplied, recommended and released by BRP-Powertrain. If the motor is equipped by extra accessories it must be provided (and proven) that the engine under all operating conditions comply with the limits prescribed by ROTAX.</p>
<b>Spare parts</b>	<p><b>NOTICE</b> Spare parts must meet with the requirements defined by the engine manufacturer. This is only warranted by use of GENUINE ROTAX spare parts and/or accessories (see IPC) or suitable equivalent in the manufacturer's opinion otherwise, any limited warranty by BRP-Powertrain is null and void (see Warranty Conditions). Spare parts are available at the authorized ROTAX Distribution- and Service Center.</p> <p>Any warranty by BRP-Powertrain becomes null and void if spare parts and or accessories other than GENUINE ROTAX spare parts and/or accessories are used (see latest Warranty Conditions).</p>
<b>Tools</b>	<p><b>NOTICE</b> In principle use only tools and appliances which are either cited in the Manual or in the Illustrated Parts Catalog.</p>
<b>Standstill</b>	<p>After engine standstill (longer than 2 months) observe without fail the instructions for engine "out of use". Protect fuel- and carburetor system against contamination.</p>
<b>Returning</b>	<p>When returning the engine or its components (e.g. propeller gearbox) to an authorized overhaul or</p>

**BRP-Powertrain**  
MAINTENANCE MANUAL

repair company, ensure that the necessary documentation (log book, maintenance records etc.) are enclosed.

---

### 3.3) Maintenance Concept

<b>General note</b>	<p>The maintenance functions detailed in this Manual fall into two categories:</p> <ul style="list-style-type: none"><li>- Maintenance I (Line Maintenance)</li><li>- Maintenance II (Heavy Maintenance)</li></ul> <p>Repairs beyond the levels detailed in this Manual are not recommended as maintenance functions and must be done by an authorized overhaul facility.</p>
<b>Maintenance I (Line Maintenance)</b>	<p>Chapter 00,05 and 12</p> <p>The scope of line maintenance consists of removal, installation and adjustment of engine components (including part wear). All procedures in this Manual are to be considered line maintenance.</p> <p>NOTES:           Where applicable, you will be referred to the Heavy Maintenance Manual for work above and beyond line maintenance.</p>
<b>Maintenance II (Heavy Maintenance)</b>	<p>separate Manual</p> <p>Maintenance Manual II details removal, installation and repair of components or parts normally considered beyond the capabilities of the "Line Maintenance".</p> <p>NOTES:           This Manual can <b>only</b> be used in combination with Maintenance Manual I (Line Maintenance), as it builds up on it.</p>

---

d05553.fm

**BRP-Powertrain**  
MAINTENANCE MANUAL

### 3.4) Technical documentation

<b>General note</b>	<p>These documents form the instructions ensuring continued airworthiness of ROTAX aircraft engines.</p> <p>The information contained is based on data and experience that are considered applicable for authorized mechanics (iRMT) under normal conditions.</p> <p>Due to the fast technical progress and fulfilment of particular specifications of the customers it may occur that existing laws, safety prescriptions, constructional and operational regulations cannot be transferred completely to the object bought, in particular for special constructions, or may not be sufficient.</p> <hr/>
<b>Documentation</b>	<ul style="list-style-type: none"><li>- Installation Manual</li><li>- Operators Manual</li><li>- Maintenance Manual (Line and Heavy Maintenance)</li><li>- Overhaul Manual</li><li>- Illustrated Parts Catalog</li><li>- Alert Service Bulletin</li><li>- Service Bulletin</li><li>- Service Instruction</li><li>- Service Letter</li></ul> <div style="text-align: right;"></div> <hr/>
<b>Status</b>	<p>The status of the Manuals can be determined with the aid of the table of amendments. The first column indicates the revision state. This figure should be compared with the revision provided on ROTAX-WebSite: <a href="http://www.FLYROTAX.com">www.FLYROTAX.com</a>.</p> <p>Amendments and current versions can be downloaded free of charge.</p> <hr/>
<b>Replacement pages</b>	<p>Furthermore the Manual is constructed in such a way that single pages can be replaced instead of the complete document. The list of effective pages is given in the chapter LEP. The particular edition and revision number is given on the footer of each page.</p> <hr/>
<b>Reference</b>	<div style="background-color: #0056b3; color: white; padding: 5px; display: inline-block;"><b>NOTICE</b></div> This Manual for maintenance is only part of the Technical Documentation and will be supplemented by the respective Operators Manual, Installation Manual, Overhaul Manual and Illustrated Parts Catalog. Pay attention to references to other documentation, found in various parts of this Manual. <p>Any reference to a document refers to the latest edition issued by BRP-Powertrain, if not stated otherwise.</p> <hr/>

d05553.fm

# BRP-Powertrain

## MAINTENANCE MANUAL

### Illustrations

The illustrations in this Manual are mere sketches and show a typical arrangement. They may not represent in full detail or the exact shape of the parts which have the same or similar function. Therefore deduction of dimensions or other details from illustrations is not permitted.

NOTES: The Illustrations and Documents in this Manual are stored in a document data file/graphic data file and are provided with a consecutive irrelevant number.

This number (e.g. 00277) is of no significance for the content.

---

**BRP-Powertrain**  
MAINTENANCE MANUAL

### 3.5) Use for intended purpose

<b>General note</b>	 <b>WARNING</b> Explosion hazard. Bursting off parts can cause serious injuries. Never run the engine without propeller.
<b>Use</b>	The engine ROTAX 912 A/F/S is intended for use in certified aircraft. In case of doubt the regulations of the national authorities or the respective sportive federations have to be observed.
<b>Certified engine</b>	Certified aircraft engine ROTAX 912 A/F/S is tested as per aeronautical standards for safety and time between overhaul. It was developed to conform to the latest technological standards and rigorously tested.
<b>Non certified engine</b>	Engine ROTAX 912 UL/ULS/ULSFR is not certified. These engines have not received any aeronautical standards or regulatory safety or durability testing, and conform to no aircraft standards. These engines are for use in experimental, uncertificated aircraft and vehicles only in which an engine failure will not compromise safety.  NOTES:            These engines are technically equivalent to certified engines and have been manufactured by BRP-Powertrain using the same quality assurance system.
<b>Engine stoppage</b>	The operator assumes all risk of use, and acknowledges by this use that he/she knows this engine is subject to sudden stoppage.
<b>Maintenance and repair conditions</b>	Use for intended purpose also includes observation of the operational, maintenance and repair conditions prescribed by the manufacturer. This is a crucial factor concerning the reliability of the engine and can increase the durability of the engine.

d05553.fm

**Chapter: 04-00-00**  
**AIRWORTHINESS LIMITATIONS**

**Approval**

THE AIRWORTHINESS LIMITATIONS SECTION IS APPROVED BY THE EUROPEAN AVIATION SAFETY AGENCY (EASA) IN ACCORDANCE WITH PART 21A.31(a)(3) AND FAR 33.4. ANY CHANGE TO EACH MANDATORY REPLACEMENT TIME, INSPECTION INTERVAL, AND RELATED PROCEDURE CONTAINED IN THIS AIRWORTHINESS LIMITATIONS SECTION MUST ALSO BE APPROVED.

no.	chapter	page	date of change	remark for approval	date of approval from authorities	date of issue	signature
1	04-00-00	all	09 01 2012	EASA approved			

**Introduction** This chapter 04-00-00 provides information about “Airworthiness Limitations”.

---

**Airworthiness Limitations** - **NONE**

For the ROTAX type engine 912 Series the airworthiness limitations are not applicable.

**NOTE:** Regarding engine operating limitations see the relevant chapter “limits of operation“ in the relevant Operators Manual.

Maintenance checks and replacement of defined components are required on this engine! These procedures are described in chapter 05 and are a required by the authority in order to ensure the Continued Airworthiness!

See chapt. 05-00-00.

---

**Continued Airworthiness** Scheduled inspections of the engine including replacement and overhaul of defined components are required in order to ensure the Continued Airworthiness of ROTAX aircraft engines.

---

**BRP-Powertrain**  
MAINTENANCE MANUAL

NOTES

d05554.fm

**BRP-Powertrain**  
MAINTENANCE MANUAL

**Chapter: 05-00-00**  
**MAINTENANCE**

**Introduction**      The information given in the Maintenance Manual is based on data and experience which are considered to be applicable for a skilled aviation mechanic under normal working conditions

---

**Table of contents**      In this chapter the maintenance of engine ROTAX 912 Series is described. The description is subdivided into sections and description of function of the various systems. Some overlapping maintenance instructions are treated as generally valid information at the beginning of this section.

Subject	Page
Maintenance	page 3
General note	page 3
Authorized personnel	page 4
Procedure notes	page 6
Trouble shooting	page 8
Consumable materials	page 9
Acceptable methods	page 12

---

d05555.fm

**BRP-Powertrain**  
MAINTENANCE MANUAL

NOTES

**BRP-Powertrain**  
MAINTENANCE MANUAL

**1) Maintenance**

**1.1) General note**

**Safety notice**



Non-compliance can result in serious injuries or death! Besides our instructions in the documentation supplied, also respect the generally valid safety and accident preventive directives and legal regulations.

---

**Procedures and limits**

The procedures and limits in this Manual constitute the manufacturers official recommendation for engine maintenance and operation.

---

**Instruction**

The guidelines given in the Maintenance Manual are useful and necessary supplements to training. They, however, cannot substitute competent theoretical and practical personal instruction.

---

**Modifications**

Non-authorized modifications as well as the use of components and auxiliary components not corresponding to the installation instructions exclude any liability of the engine manufacturer.

---

**Parts and accessories**

We particularly emphasize that parts and accessories not supplied as genuine BRP-Powertrain parts are not verified for suitability by BRP-Powertrain and thus are not authorized for use. Installation and/or use of such products may possibly change or negatively influence the constructive characteristics of the engine. For damages resulting from use of NON-GENUINE ROTAX parts and accessories manufacturer refuses any liability.

---

**Special tools**

Maintenance of engines and systems requires special knowledge and special tools. Use only the special tools recommended by BRP-Powertrain when disassembling and assembling the engine.

---

**BRP-Powertrain**  
MAINTENANCE MANUAL

**1.2) Authorized personnel**

**General note** It is a requirement that all organizations or individuals possess the required special tooling. Technicians must have type-specific training and keep a recurrent knowledge status for the level of work they intend to perform. Technicians may require accreditation from their local aviation authority in addition to any BRP-Powertrain requirements.

**Type-specific training** Any task outlined herein may be performed if the organization or individual has met the following conditions:

<b>Requisite knowledge of the task as a result of:</b>
- Type-specific training (for the applicable ROTAX aircraft engine) which is approved by the national aviation authority and/or BRP-Powertrain.
<b>or</b>
- Experience in performing the task <b>or</b> - Formal instruction from a BRP-Powertrain authorized training facility <b>or</b> - Instruction by an authorized BRP-Powertrain Distributor representative.
<b>Including:</b>
- Suitable work environment to prevent contamination or damage to engine parts or modules. - Suitable tools and fixtures as outlined in the ROTAX Maintenance Manual. - Reasonable and prudent maintenance practices are utilized. - And the Requirements of the applicable regulatory authority regarding maintenance procedures are met.

**Information** Maintenance organizations and individuals are encouraged to contact BRP-Powertrain through its worldwide distribution network for information and guidance on any of the tasks outlined herein. See chap. 00-00-00 section: 3.4).

d05555.fm

**BRP-Powertrain**  
MAINTENANCE MANUAL

**Type-specific training**

<b>Type-specific training:</b>
- Independent ROTAX Maintenance Technician (iRMT) training can be obtained from a ROTAX approved training organization. Courses are available in various levels to suit the requirements of work the technician needs to perform. Each rating is valid for a 2 year period.

**Valid time**

ROTAX iRMT specialty ratings are valid for a 2 year period after initial instruction. Recurrent training is required after 2 years to maintain a current status. In order to be eligible for the renewal program training, the technician must be able to show and declare that they have been working on ROTAX engines during the past 2 years.

---

d05555.fm

### 1.3) Procedure notes

**General note**



Non-compliance can result in serious injuries or death!  
When carrying out maintenance and service work, respect without fail the safety regulations.

---

**Ignition "OFF"**



Non-compliance can result in serious injuries or death!  
This precautionary measure serves to avoid any injuries in case of an unintentional start of the engine.  
Principally ensure the following at **each maintenance event**

- Ignition "**OFF**" and system grounded,
- Disconnect battery and secure engine against unintentional operation.

---

**Ignition "ON"**



Risk of electric shock!  
The ignition is **switched on**, as long as the ground-cable (P lead) is not properly connected to ground.

At maintenance work which requires ignition "ON" and battery connected, take care of the following:

- Secure the propeller against unintentional turning by hand and
  - Secure and observe propeller zone
- 

**Handling of operating fluids**



Failure to comply with this instruction may cause severe burns or scalding!  
Hot engine parts!  
Always allow the engine to cool down to ambient temperature before starting work.

At maintenance of cooling-, lubricating and fuel system take care without fail that no contamination, metal chips, foreign material and/or dirt enters the system.

---

**Disassembly**

At disassembly of the engine, mark the components as necessary to avoid any mix-up. Take care of these marks, don't ruin them.

---

**BRP-Powertrain**  
MAINTENANCE MANUAL

<b>Tool</b>	<b>NOTICE</b>	In order to avoid mechanical damages, never loosen or tighten screws and nuts with pliers but only with the specified tools.
<b>Safety wiring</b>	<b>NOTICE</b>	If during disassembling/reassembling the removal of a safety item (e.g. safety wiring, self-locking fastener, etc.) should be necessary, it must be always replaced by a new one.
<b>Cleaning of parts</b>	<b>NOTICE</b>	All metall and synthetic parts are generally washed with suitable cleaning agents. Before using new and unknown cleaning agents check the compatibility of materials.
<b>Removed parts</b>		Before re-using disassembled parts, clean, check and refit them as per instructions.  Use clean screws and nuts only and inspect face of nuts and thread for damage. Check the contact faces and threads for damages. In case of doubt, use new screws and nuts.
<b>Nuts</b>		Once loosened, <b>always</b> replace self-securing nuts.  <b>WARNING</b> Non-compliance can result in serious injuries or death! Exactly observe the tightening torques for screws and nuts. Overtightening or too loose connection could cause serious engine damage.
<b>Sealing rings, O-rings</b>		At reassembly of the engine, replace all sealing rings, gaskets, securing elements, O-rings and oil seals.
<b>Re-assembly</b>		Before re-assembly check components whether parts are missing. Only use adhesives, lubricants, cleaning agents and solvents indicated in the maintenance instructions. If not respected, damage may be the consequence.

d05555.fm

**BRP-Powertrain**  
MAINTENANCE MANUAL

**1.4) Trouble shooting**

**General notes**      In the Operators Manual, possible problems are listed. At the same time, a brief description of the necessary remedial action is given.  
See chapter 4 in the Operators Manual for engine type 912 (Series).

---

d05555.fm

**BRP-Powertrain**  
MAINTENANCE MANUAL

## 1.5) Consumable Materials

General note

**NOTICE**

Use only the specified or **technically equivalent** materials from BRP-Powertrain for all maintenance work. When handling chemicals, comply with all the customary regulations and specifications of the producer, including the expiry date and instruction.

**NOTES:** To some extent product descriptions deviate in spite of equivalent technical properties, i.e.: LOCTITE 221 and LOCTITE 222. If necessary contact the manufacturer concerning the comparability. In some cases information can be obtained from the local authorized distributors and service partners for ROTAX engines.

**NOTES:** Respect the manufacturers instruction concerning the curing time and the expire date of the particular surface sealing compound.

The materials specified have been tested for a long time and are suitable for all operating conditions indicated by the manufacturer.

No.	part no.	Description, Application	Qty.
1	899785	<b>LOCTITE 221 violet</b> , medium-duty screw securing agent	10 ml (0.003 gal (US))
2	897651	<b>LOCTITE 243 blue</b> , medium-duty screw securing agent	10 ml (0.003 gal (US))
3	899788	<b>LOCTITE 648</b> , high strength screw securing agent	5 ml (0.001 gal (US))
4	899789	<b>LOCTITE 603 green</b> , oil-tolerant grouting product, high-strength	10 ml (0.003 gal (US))
5	898241	<b>LOCTITE 480 black</b> , instant adhesive increased flexibility	20 ml (0.005 gal (US))
6	899784	<b>LOCTITE 574 orange</b> , surface sealing compound	50 ml (0.013 gal (US))
7	n.a.	<b>LOCTITE 518 red</b> , surface sealing compound, can be used instead LOCTITE 574	
8	899791	<b>LOCTITE 5910 black</b> , surface sealing compound, can be used instead LOCTITE 574 and LOCTITE 518	50 ml (0.013 gal (US))
9	297434	<b>LOCTITE Anti-Seize 8151</b> , for the prevention of fretting corrosion	50 g (0.11 lb)
10	297433	<b>MOLYKOTE G-N</b> , Lubricating paste	100 g (0.22 lb)
11	897166	<b>MOLYKOTE 44 medium</b> , long-term lubricant for shaft seals	100 g (0.22 lb)

d05555.fm

**BRP-Powertrain**  
**MAINTENANCE MANUAL**

No.	part no.	Description, Application	Qty.
12	897330	<b>Lithium-base grease or Dow Corning,</b> to prevent leakage current	250 g (0.55 lb)
13	897870	<b>Filter oil</b> for optimum filter efficiency and protection against moisture	14.8 ml (0.004 gal (US))
14	297368	<b>SILASTIC 732,</b> multi-purpose one-component silicon-based sealing compound	310 ml (0.082 gal (US))
15	897186	<b>SILICONE HEAT CONDUCTION COMPOUND</b> Application of the heat conduction compound will reduce heat transfer resistance. The grease- like, temperature-resistant silicon compound fills cavities between components and the cooling element (e.g.: spark plug-cylinder head), which otherwise do not contribute to heat conduction.	150 g (0.33 lb)
16	297711	<b>PU-glue</b> for shock absorption	310 ml (0.082 gal (US))
17	n.a.	<b>Multi-purpose grease LZ</b> Generally useable, neutrally colored multi-pur- pose grease, water resistant and highly adher- ent. Useable for temperatures from -35 °C to +120 °C (-31 °F to +248 °F) and can be subject- ed to mechanical loads.	
18	n.a.	<b>Preservation oil</b> Requirements: The preservation oil has excel- lent penetrating capabilities and reaches even tiny gaps, it's highly effective additives protect against corrosion of metal surfaces.	
19	n.a.	<b>Very fine emery cloth SR 4600 A - very fine standard</b> Is sold by the meter and used for Manual remov- al of smaller rust spots or oxidation, especially for optimum ground connections. It is highly suit- able for removing LOCTITE from surfaces or threads to make them metallic clean. Before re- applying LOCTITE, clean surfaces with ni- trothinner or degreasing agent (CASTROL ZA 30 or OMV-SOFT SOL). When using solvents, observe the safety regulations for persons and environment.	
20	898570	<b>Screw securing paint</b> seals screws	20 ml (0.005 gal (US))

d05555.fm

**BRP-Powertrain**  
**MAINTENANCE MANUAL**

No.	part no.	Description, Application	Qty.
21	n.a.	<p><b>Cleaning agents</b></p> <p><b>NOTICE</b> Use only approved cleaning agents (e.g. kerosine, varsol, etc.) for cleaning all metal parts.</p> <p>Do not use lye-based cold cleaner or degreasing agents. Do not clean coolant or oil hoses with aggressive solutions. Clean off sealing compound residue with sealant remover.</p> <p>Soak combustion chamber, piston and cylinder head with cleaning agent and remove combustion residues with a bronze brush. Very good results have been achieved with "Clenvex 2000". It is a solvent-cold cleaner, free of halogen, on the basis of selected fuel fractions with tensides and is biologically disposable.</p> <p>Never use caustic or corrosive cleaning agents.</p>	
22	n.a.	<p><b>MICRONORM abrasive</b></p> <p>This abrasive is suitable for local and gradual very fine treatment of steel parts with rust film (propeller shaft). The MICRONORM abrasive contains no noxious matter, is approved by the relevant authorities and guarantees optimum cleaning. The granulates used are of sizes 40 to 60 <math>\mu</math>. It is possible to achieve a surface roughness of 0,5 to 1 <math>\mu</math>, which represents fine processing of surfaces.</p>	
23	n.a.	<p><b>LOCTITE 7063</b></p> <p>Degreasing fluid. For parts cleaning before application of adhesives and sealants.</p>	

d05555.fm

**BRP-Powertrain**  
MAINTENANCE MANUAL

**1.6) Acceptable methods, techniques and practice**

**General note** All general inspection, maintenance and repair has to be carried out in accordance with Advisory Circular AC 43.13 from FAA.

---

**Advisory Circular** This Manual "Advisory Circular" AC describes maintenance methods, techniques and practice. These are recognized and authorized for inspection and repairs in non-pressurized areas for which there are no separate maintenance and repair instructions.

---

**Self-locking** **NOTICE** Self-locking nuts, cotter pins, tab washers and safety wires must be replaced each time they have been removed.

Respect without fail all additional indications regarding securing and sealing means and lubrication of fixation elements. Adhere to specified tightening torques.

---

**Nut securing** When using a self-locking nut, take care that the polyamide insert ring on nuts according to DIN 985 as well as the securing element on nuts according to DIN 980 is positioned towards outside.

---

**Lock washer** **NOTES:** When fitting lock washers, the curved-up ends (1) must point towards the screw head or nut.

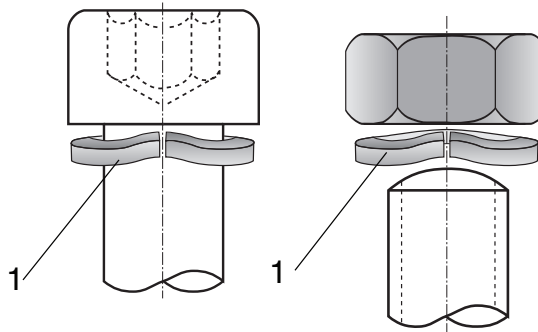

00144

**BRP-Powertrain**  
MAINTENANCE MANUAL

**Chapter: 05-10-00**

**TIME LIMITS**

**Introduction**      These checks, related to limited periods of operation, are planned to help avoid engine troubles by the use of preventive maintenance.

---

**Table of contents**      This chapter of the Maintenance Manual contains general information regarding TBO and time limits on rubber components.

Subject	Page
Definition of terms	page 3
Operating hours	page 3
Time limits	page 3
Life cycle	page 3
General Overhaul (TBO)	page 4
Purging the oil system	page 4
Time limit	page 5
Time limit for rubber parts	page 8
Time limit for fuel pump	page 8
Time limit for the coolant	page 8
Annual inspection	page 8

---

d055556.fm

**BRP-Powertrain**  
MAINTENANCE MANUAL

NOTES

## 1) Definition of terms

### 1.1) Operating hours

**Definition**

All of the maintenance intervals, such as the 100 hr. inspection and the engine TBO, relate to the number of operating hours of the engine.

The operating hours are defined as follows in order to prevent misunderstandings and to ensure safety:

- All time during which the engine is running is counted towards the total number of operating hours.
- The time is counted irrespective of the load factor of the engine, such as idling or take-off power.

**NOTES:** A mechanical hour meter is directly coupled to the engine speed, the readings may deviate considerably from those given by electronic remitters (e.g. TCU, FlyDat). Maintenance and overhaul intervals are always dictated by the readings of the electronic hour meter.

- The planned inspections to be performed at certain intervals are based on experience from long test runs and field observations. They are intended as precautionary maintenance measures in order to ensure continued trouble-free operation of the engine.
- 

### 1.2) Time limit

**Definition**

Time limits are predetermined time spans and intervals which are based either on calendar intervals or the number of engine operating hours. Once the time limits have been reached, the affected parts must either be replaced for a general overhaul, or maintenance work must be performed. These precautionary maintenance measures are designed to avoid engine malfunctions or defects and ensure continued airworthiness of the engine.

---

### 1.3) Life cycle

**Definition**

The life cycle is always specified as an exact time span and is also quoted in flight hours.

**NOTES:** Parts with a limited life cycle must be taken out of operation and overhauled if the specified time span or number of flight hours is reached (whichever comes first).

---

**BRP-Powertrain**  
MAINTENANCE MANUAL

**1.4) General overhaul (TBO)**

<b>Definition</b>	<p>The time between overhauls (TBO) for all objects (such as the engine, component assemblies, add-on components) is the approved length of operation under normal operating conditions before it becomes mandatory to send in these objects for an overhaul.</p> <p>Normal operating conditions are the conditions which comply with the manufacturer's and the aviation authority's recommendations for the certification of airworthiness.</p> <hr/>
<b>Maintenance of operation</b>	<p>The TBO values approved by the relevant authorities are based on performance tests and empirical values which have been gathered through operation of the engine and are required for the acceptance and certification of airworthiness. TBO values can be changed in response to possible upgrade/expansion programs.</p> <hr/>
<b>Legal obligation to keep</b>	<p>TBO values for the engine are always shown in operating hours and years. The user must record the operating hours in the engine log book.</p> <hr/>

**1.5) Purging the oil system**

<b>General note</b>	<p>Purging of the oil system is extremely important for operation and service life of the engine and therefore the procedure must be followed meticulously.</p> <p>See latest installation manual Chapt. 79-00-00 "Purging the lubrication system".</p> <hr/>
---------------------	---

## 2) Time limit

### General

**NOTICE**

A general overhaul is due after a defined period of operation or after a specified calendar life since initial start of operation (whichever comes first).

The time limit for engine operation will be specified by the TBO.

---

### After reaching this time limit

**NOTICE**

After reaching this time limit, the engine has to be shipped to an authorized ROTAX overhaul facility.

For an overhaul, the engine must be removed from the aircraft, be cleaned, preserved and all openings to be closed to prevent entering of contaminants.

---

### Storage period of the engine

Observe the storage and preservation directives!

NOTE: The maximum possible storage period of the engine is limited to 24 months.

If this period is exceeded, the engine must be sent to an ROTAX authorized overhaul facility for inspection.

---

**BRP-Powertrain**  
**MAINTENANCE MANUAL**

<b>Engine Type description</b>	<b>engine affected engine S/N</b>	<b>TBO Time Between Overhaul</b>
<b>912 A</b>	up to and incl. 4,076.191	600 hr. or 10 years, whichever comes first <sup>(1)</sup>
<b>912 A</b>	from 4,076.192 up to and incl. 4,410.065	1000 hr. or 10 years, whichever comes first <sup>(1)</sup>
<b>912 A</b>	from 4,410.066 up to and incl. 4,410.471	1200 hr. or 10 years, whichever comes first <sup>(1)</sup>
<b>912 A</b>	from 4,410.472 up to and incl. 4,410.856	1500 hr. or 12 years, whichever comes first <sup>(1)</sup>
<b>912 A</b>	from 4,410.857	2000 hr. or 15 years, whichever comes first
<b>912 F</b>	up to and incl. 4,412.585	1000 hr. or 10 years, whichever comes first <sup>(1)</sup>
<b>912 F</b>	from 4,412.586 up to and incl. 4,412.816	1200 hr. or 10 years, whichever comes first <sup>(1)</sup>
<b>912 F</b>	from 4,412.817 up to and incl. 4,412.974	1500 hr. or 12 years, whichever comes first <sup>(1)</sup>
<b>912 F</b>	from 4,412.975	2000 hr. or 15 years, whichever comes first
<b>912 S</b>	up to and incl. 4,922.776	1200 hr. or 10 years, whichever comes first <sup>(1)</sup>
<b>912 S</b>	from 4,922.777 up to and incl. 4,923.889	1500 hr. or 12 years, whichever comes first <sup>(1)</sup>
<b>912 S</b>	from 4,923.890	2000 hr. or 15 years, whichever comes first
<b>912 UL</b>	up to and incl. 4,152.666	600 hr. or 10 years, whichever comes first <sup>(1)</sup>
<b>912 UL</b>	from 4,152.667 up to and incl. 4,404.717	1200 hr. or 15 years, whichever comes first <sup>(1)</sup>
<b>912 UL</b>	from 4,404.718 up to and incl. 4,409.715	1500 hr. or 15 years, whichever comes first <sup>(1)</sup>
<b>912 UL</b>	from 4,409.716	2000 hr. or 15 years, whichever comes first
<b>912 ULS</b>	up to and incl. 4,427.532	1200 hr. or 10 years, whichever comes first <sup>(1)</sup>
<b>912 ULS</b>	from 4,427.533 up to and incl. 6,775.789	1500 hr. or 12 years, whichever comes first <sup>(1)</sup>

d05556.fm

**BRP-Powertrain**  
MAINTENANCE MANUAL

Engine Type description	engine affected engine S/N	TBO Time Between Overhaul
<b>912 ULS</b>	from 6,775.790	2000 hr. or 15 years, whichever comes first
<b>912 ULSFR</b>	up to and incl. 4,429.714	1200 hr. or 10 years, whichever comes first <sup>(1)</sup>
<b>912 ULSFR</b>	from 4,429.715 up to and incl. 6,775.789	1500 hr. or 12 years, whichever comes first <sup>(1)</sup>
<b>912 ULSFR</b>	from 6,775.790	2000 hr. or 15 years, whichever comes first

For the TBO of the specific engine type/version refer to the table below.

<sup>(1)</sup> Extension of the TBO is possible and will be specified by a Service Bulletin (SB) for the respective engine type. For extensions already effective refer to the engine log book or release certificate.

**Authorized exceeding**

Extension or exceeding of the TBO by 5 % or 6 months is allowed whichever comes first.

**Shipment**

The shipment to an authorized ROTAX overhaul facility must include the following:

1	Engine log book.
2	Maintenance records of the engine (i.e. all maintenance check lists, and reports of operation, of maintenance, of findings and of oil analyses).
3	The engine assembly as per supply volume. Additionally all added-on parts as in the supply volume such as carburetors, filters, fuel pump, external generator, sensors, ignition unit, electric starter, oil tank.
4	Indication of total engine operating hours (TSN) and where applicable, engine operating hours since a previous overhaul (TSO). NOTE: This information must be supplied to allow the service history of components to be traced.
5	Data about the type of aircraft used.
6	Useful remarks and observations concerning the engine.

d05556.fm

**BRP-Powertrain**  
MAINTENANCE MANUAL

## 2.1) Time limit for rubber parts

General note

**NOTICE**

This time limit must be followed **independently** and **in addition** to the visual inspections (see chap. 05-20-00 section: 5.1)) of the respective components.

Time limit

The following components and systems must be replaced every 5 years:

- venting hose of the carburetors	
- all rubber hoses of the cooling system	
- all rubber hoses of the fuel system (incl. teflon hoses)	Fuel pump and insulating flange, if this is fixed with fuel hoses.
- venting hose of the fuel pump	
- all rubber hoses of the lubrication system which are part of the engine supply volume and if they are not in the maintenance schedule of aircraft manufacturer	
- carburetor sockets	
- connecting hose of the air intake system	
- diaphragm on both carburetors	
- rubber hoses on compensating tube	
- V-belt	

## 2.2) Time limit for fuel pump

General note

The fuel pump must be replaced every 5 years.

## 2.3) Time limit for the coolant

General note

Coolant must be replaced as per manufacturers instructions, at the latest during overhaul or when the engine is replaced.

## 2.4) Annual inspection

General note

A 100 hr. inspection is to be carried out periodically after every 100 hours of operation **or every 12 months**, whichever comes first.  
See chap. 05-10-00 section: 2).

d05556.fm

**BRP-Powertrain**  
MAINTENANCE MANUAL

**Chapter: 05-20-00**  
**SCHEDULED MAINTENANCE CHECKS**

**Introduction**

The owner and/or user is primarily responsible for the maintenance and airworthiness of the engine. This includes compliance with all applicable airworthiness directives.

This inspection protocol is not intended to be all-inclusive, for no such protocol can replace the knowledge and experience of a certified aircraft mechanic. As the party primarily responsible for the maintenance and airworthiness of the engine, the owner or user should only have the maintenance work carried out by qualified engineers.

**Documentation required**

It is the responsibility of the owner and/or user to make sure that the aircraft mechanic performing the work on the engine has access to the previous Inspection Protocols and any other required documents.

**Table of contents**

This chapter of the Maintenance Manual contains general information regarding periodic maintenance and the maintenance check list.

Subject	Page
Scheduled maintenance checks	<a href="#">page 3</a>
Unscheduled maintenance checks	<a href="#">page 5</a>
Visual inspection	<a href="#">page 7</a>
Maintenance schedule procedures	<a href="#">page 9</a>
Check list/Maintenance schedule	<a href="#">page 11</a>
Maintenance schedule	<a href="#">page 13</a>

d05557.fm

**BRP-Powertrain**  
MAINTENANCE MANUAL

NOTES

**BRP-Powertrain**  
MAINTENANCE MANUAL

**1) Scheduled maintenance checks**

**Definition** This section lists the periodic inspections which must be carried out after a specified periods of operation.

**Intervals** Periodic inspections are those which must be performed at 25, 100, 200, 600 hr. intervals in accordance with chapt. 05-20-00. section: 5.1).

This means for example that **every 100 hr.** of operation a 100 hr. check must be carried out. Every 200 hr. of operation a 100 hr. and the additional checks for 200 hr. must be carried out.

	Intervals - hours								to	2000 hr
	25 hr	100 hr	200 hr	300 hr	400 hr	500 hr	600 hr	700 hr		
100 hr	X	X	X	X	X	X	X	X		X
200 hr			X		X		X			
600 hr							X			

- 100 hr. check**
- In order to demonstrate continued airworthiness, an engine must be inspected after every 100 hours of operation or 12 months.
  - For the intervals between maintenance work, a tolerance of  $\pm 10$  hr. is permissible, but these tolerances must not be exceeded. This means that if a 100 hr. check is actually carried out at 110 hr., the next check will be due at 200 hr.  $\pm 10$  hr. and not at 210 hr.  $\pm 10$  hr.
  - If maintenance is performed before the prescribed interval, the next maintenance check is to be done at the same interval (e.g. if first 100 hr. check is done after 87 hours of operation, the next 100 hr. check must be carried out after 187 hours of operation).
  - If engine has less than 100 hours of operation during one year a 100 hr. check must be carried out. For the annual inspection a tolerance of  $\pm 2$  months is given.

**Special hr. check** NOTES: This maintenance schedule contains a column for a 50 hr. check. This check is recommended by the manufacturer but not essential, with the exception of oil change when operating with leaded AVGAS.

d05557.fm

## BRP-Powertrain

### MAINTENANCE MANUAL

#### 25-hr. check

- In order to demonstrate continued airworthiness, an engine must be inspected after the first 25 hours of operation.
  - The checks performed at the 25 hr. inspection are the same as for the 100 hr. inspection. This applies both to newly delivered engines and to overhauled engines.
-

**BRP-Powertrain**  
MAINTENANCE MANUAL

**2) Unscheduled maintenance checks**

**Operating limits exceeded** An inspection of the engine must be performed if the operating limits of the engine have been exceeded (e.g. overspeed, excessive temperature etc.), or if unusual operating conditions have occurred during operation (e.g. lightning strike). In such cases the engine must be inspected in accordance with the applicable unscheduled maintenance checks. (See [chapter 05-50-00](#)).

**Recommends inspections** The manufacturer also recommends the following inspections whenever maintenance is carried out (where not already prescribed by the airframe manufacturer, as possible malfunctions could have negative effects on engine operation).

part	inspection	possible danger
<b>Engine cowling</b>	- for discoloring and warping.	Danger of overheating
<b>Exhaust fixation</b>	- re-tighten the exhaust fixation on the cylinder head after the first 2 hr. of operation.	Leakage
<b>Exhaust</b>	- of the exhaust unit (where necessary, replaced application of LOCTITE Anti-Seize).	Risk of fracture, wear. Smooth engine running.
<b>Fuel filter</b>	- of fuel filter on airframe side (for foreign bodies, sealing material and loose fragmented material).	Engine to misfire. Power loss. Engine running too lean (Engine malfunction and damage).
<b>Electr. fuel pump</b>	- correct function.	Insufficient fuel supply. Engine running too lean (Engine malfunction and damage).
<b>Battery</b>	- acid concentration for each cell Observe the manufacturers instruction.	Starting problems
<b>Oil</b>	- for oil contamination. - analyse the oil (provides additional information on the condition of the engine).	Possible engine wear
<b>Radiators, Lines</b>	- for damage. - check for discoloration - and cracks.	Danger of overheating
<b>Propeller</b>	- undamaged and runs true - carry out dynamically balancing including verification of propeller track.	Engine damage, unusual vibrations

d05557.fm

**BRP-Powertrain**  
MAINTENANCE MANUAL

<b>Cell-side air intake system (NACA intake)</b>	- as specified by the cell manufacturer	See specifics of manufacturer.
<b>Cell-side attachment points of engine suspension</b>	- as specified by the cell manufacturer	See specifics of manufacturer.
<b>Throttle control</b>	- as specified by the cell manufacturer	See specifics of manufacturer.
<b>Governor</b>	- as specified by the cell manufacturer	See specifics of manufacturer.

**BRP-Powertrain**  
MAINTENANCE MANUAL

### 3) Visual inspection

<b>General note</b>	The scope of a visual inspection generally includes, but is not necessarily limited to, the following.
<b>Moving parts</b>	Normal operating condition, accurate alignment, leak-tightness, cleanliness, ease of movement, adjustment, mechanical stress, travel, catching, extreme wear, cracks, corrosion, deformation and other visually evident damage.
<b>Parts</b>	Secure seating, surface condition, cleanliness, deformation, cracks in welding seams or due to material fatigue or stress, corrosion and other visually evident damage.
<b>Fuel-, Air- and Oil lines</b>	Cracks, dents, kinks, required flexibility, collapsed lines/hoses, abrasion, cleanliness, secure seating and other visually evident damage.
<b>Wiring</b>	General cleanliness; loose, corroded or broken terminals; chafed, broken or worn insulation; secure seating, heat damage and other visually evident damage.
<b>Screws and Nuts</b>	Surface damage, secure seating, locking wire, securing paint and other visually evident damage.
<b>Filter</b>	Filters and screens must be inspected for contamination and potential blockages, cleaned and replaced as required.

d05557.fm

**BRP-Powertrain**  
MAINTENANCE MANUAL

NOTES

**BRP-Powertrain**  
MAINTENANCE MANUAL

**4) Maintenance schedule procedures (maintenance check list)**

<b>Inspections</b>	All stated checks are visual inspections for damage and wear, unless otherwise stated.
<b>Specified period</b>	All listed work must be carried out within the specified period.
<b>Maintenance check lists</b>	Checks are carried out as per the maintenance check lists, where type and volume of maintenance work is outlined in key words. See chapter 05-20-00 section 5.1). <ul style="list-style-type: none"><li>- The lists must be photocopied and filled out for each maintenance check.</li></ul>
<b>Extra inspections</b>	<ul style="list-style-type: none"><li>- The respective check (e.g. 100 hr. check) must be noted on the top of each page of the maintenance check list.</li><li>- All the maintenance work carried out must be initialled in the "signature" area by the aircraft mechanic performing the task.</li></ul>
<b>Maintenance records</b>	After maintenance, the completed check lists must be entered in the maintenance records. The maintenance must be confirmed in the log book.
<b>Discrepancies/remedial action</b>	All discrepancies and remedial action must be recorded in a report of findings to be generated and maintained by the company authorized to carry out maintenance work. It is the responsibility of the aircraft operator to store and keep the records.
<b>Replacement of equipment</b>	Replacement of equipment (e.g. fuel pump, governor....) and execution of SB (LTA) must be entered in the engine log book, stating S/N, TSN and date.

d05557.fm

**BRP-Powertrain**  
MAINTENANCE MANUAL

NOTES

**BRP-Powertrain**  
 MAINTENANCE MANUAL

**5) Check List/Maintenance Schedule**

Identification	
<b>AIRCRAFT</b>	
Registration number	
Aircraft make	
Aircraft model and S/N	
Time since new	
<b>Propeller</b>	
Propeller brand	
Propeller model and S/N	
Governor brand	
Governor model and S/N	
<b>ENGINE</b>	
Engine type	
Engine S/N	
TSN (time since new)	
TSO (time since overhaul)	
Used operating fluids:	
coolant	
- mixture ratio	
fuel	
oil	
- type	
- viscosity	
<b>AIRCRAFT OPERATOR</b>	
Name	
Contact	
Address	
Telephone/Fax/E-mail	

d05557.fm

**BRP-Powertrain**  
**MAINTENANCE MANUAL**

Identification						
<b>MAINTENANCE FACILITY</b>						
Maintenance workshop						
Address						
Telephone/Fax/E-mail						
Certificate						
This check is applicable (circle on)	25 hr.	50 hr. <sup>(1)</sup>	100 hr.	200 hr.	600 hr.	1000 hr.
	<sup>(1)</sup> leaded fuel more than 30% of operation					
<b>Next check due at:</b>	_____ hr.					
	(TS _____) (engine hr.)					

d05557.fm

**BRP-Powertrain**  
MAINTENANCE MANUAL

**5.1) Maintenance Schedule**

**General note** Perform the following maintenance tasks at the intervals shown in the maintenance check list. See [chapter 05-20-00](#) 25 hr. check.

Legend: X = do the task  
blank = no task required

**NOTES:** If the points 1-3 in order to continue with the maintenance schedule.  
If one of the points 1-3 not OK, the engine must be checked and repaired in accordance with the BRP-Powertrain instructions for continued airworthiness.

Points of Inspection	Interval Operating hours		Chapter Reference	Signature
	as indicated	100 hr.		
<b>1.) Visual inspection of the engine</b>				
General visual inspection of the engine for damage or abnormalities. Check cooling air duct and cooling fins of the cylinders for obstruction, cracks, wear and good condition. Take note of changes caused by temperature influence.	recommended 50 hr.	X	12-20-00 sec. 3)	
Visual inspection of the temperature sensor and the oil pressure sensor. Inspect for tight fit and good condition.		X		
Inspect all coolant hoses for damage, including leakage, hardening from heat, porosity, loose connections and secure attachment. Verify routing is free of kinks and restrictions.		X	12-20-00 sec. 9.1)	
Carry out visual inspection of leakage bore at the base of the water pump for signs of leakage.		X	12-20-00 sec. 4)	
Inspect the expansion tank for damage and abnormalities. Check coolant level, replenish as necessary. Inspect radiator cap. Inspect protection rubber on expansion tank base for correct fit.		X	12-20-00 sec. 9.1,9.4) 12-10-00 sec. 3.1)	
Inspect the overflow bottle for damage and abnormalities. Verify coolant level, replenish as necessary. Inspect line from expansion tank to overflow bottle for damage, leakage and clear passage. Inspect venting bore in cap of overflow bottle for clear passage.		X	12-20-00 sec. 9.5) 12-10-00 sec. 3.1)	

d05557.fm

**BRP-Powertrain**  
**MAINTENANCE MANUAL**

Points of Inspection	Interval Operating hours		Chapter Reference	Signature															
	as indicated	100 hr.																	
Inspect all oil lines for damage, leakage, hardening from heat, porosity, security of connections and attachments. Verify routing is free of kinks and restrictions.		X	12-20-00 sec. 4)																
Inspect all fuel lines for damage, leakage, hardening from heat, porosity, security connections and attachments. Verify routing is free of kinks and restrictions. In the case of steel fuel lines (912 F, 912 S and/or optional), also check for any cracks and/or scuffing marks.		X	12-20-00 sec. 4)																
Inspect the wiring and its connections for secure fit, damage and signs of wear.		X	12-20-00 sec. 13.1)																
<b>2.) Magnetic plug</b>																			
Check the magnetic plug.		X	12-20-00 sec. 12)																
<b>3.) Compression check</b>																			
Check the compression by the differential pressure method. Test pressure _____ hPa (psi)	every 200 hr.		12-20-00 sec. 5)																
<table border="1"> <thead> <tr> <th align="center" colspan="5">Pressure drop (% or fraction)</th> </tr> <tr> <th align="center">Cyl #</th> <th align="center">1</th> <th align="center">2</th> <th align="center">3</th> <th align="center">4</th> </tr> </thead> <tbody> <tr> <td align="center">bar/psi</td> <td></td> <td></td> <td></td> <td></td> </tr> </tbody> </table>					Pressure drop (% or fraction)					Cyl #	1	2	3	4	bar/psi				
Pressure drop (% or fraction)																			
Cyl #	1	2	3	4															
bar/psi																			
<b>4.) Checking the engine suspension</b>																			
Inspect engine suspension and fasteners for secure fit, including damage from heat, deformation, cracks.		X	12-20-00 sec. 3.1)																
<b>5.) Checking the air intake system</b>																			
Inspect suspension and fasteners for secure fit, including damage from heat, deformation, cracks.		X																	

d05557.fm

**BRP-Powertrain**  
**MAINTENANCE MANUAL**

Points of Inspection	Interval Operating hours		Chapter Reference	Signature
	as indicated	100 hr.		
<b>6.) Engine external parts</b>				
Inspect screws and nuts of all external parts for tight fit. Inspect safety wiring, replace as necessary.		X		
<b>7.) Engine cleaning</b>				
Engine cleaning		X	12-20-00 sec. 1)	
<b>8.) Checking the air filter</b>				
Checking the air filter.		X	12-20-00 sec. 2)	
<b>9.) Checking the carburetors</b>				
Checking the idle speed.		X	12-20-00 sec.10.3.1)	
Checking the ventilation of the float chambers. Any trouble with the float chamber ventilation impairs engine and carburetor function and must therefore be avoided. Check that the passage of the ventilation lines is free and that no kinks can arise.	200 hr.			
Check for free movement of the carburetor actuation (throttle lever and starting carburetor). Check that the bowden cable allows the full travel of the throttle lever from stop to stop.		X	12-20-00 sec. 10.6)	
Removal/assembly of the two carburetors for carburetor inspection.	every 200 hr.		Heavy MM 73-00-00 sec. 3)	
Check carburetor synchronization. Mechanical and pneumatic synchronization.		X	12-20-00 sec. 10.1) 10.2) 10.3)	
Inspect the float chamber assy. for contamination and corrosion. See SI-912-021 - latest edition.	every 200 hr.		12-20-00 sec. 10.4)	
<b>10.) Inspecting carburetor sockets and drip tray</b>				
Inspect the carburetor sockets for damage and abnormalities, checking for cracks, wear and good condition. Take note of changes caused by temperature influence. ( <sup>1</sup> See SB-912-030 - latest edition.	every 200 hr. ( <sup>1</sup> )		Heavy MM 73-00-00 sec. 3.4.3)	
<b>11.) Spark plug connectors</b>				
Check that resistance spark plug connectors fit tightly on the spark plugs. Minimum pull-off force is 30 N (7 lb).	every 200 hr.			

d05557.fm

**BRP-Powertrain**  
**MAINTENANCE MANUAL**

Points of Inspection	Interval Operating hours		Chapter Reference	Signature
	as indicated	100 hr.		
<b>12.) Spark plugs</b>				
Remove all spark plugs, check the heat range designation, clean, check electrode gap and adjust if necessary. Replace as required.		X	12-20-00 sec. 13.2)	
Replacing spark plugs.	every 200 hr.	X <sup>(1)</sup>	12-20-00 sec. 13.2)	
<sup>(1)</sup> use of leaded fuel more than 30% of operation.				
<b>13.) Flushing the cooling system</b>				
Flushing the cooling system where conventional coolants are used.	when replacing the coolant		12-20-00 sec. 9.3)	
<b>14.) Checking the propeller gear box</b>				
Check the friction torque in free rotation on gearboxes with overload clutch. Actual friction torque _____ Nm (in.lbs)		X	12-20-00 sec. 14.1)	
Gearboxes with overload clutch <sup>(1)</sup> use of leaded fuel more than 30% of operation. Inspect overload clutch.	every 600 hr. <sup>(1)</sup>		05-50-00 sec. 2) SB-912-033	
Checking the propeller gearbox with overload clutch. <sup>(2)</sup> only for engine type 912 S/ULS/ULSFR	every 1000 hr. <sup>(2)</sup>		12-20-00 sec. 14.2)	
Checking the propeller gearbox without overload clutch. <sup>(3)</sup> only for engine type 912 UL/ULS/ULSFR	every 600 hr. <sup>(3)</sup>		12-20-00 sec. 14.2)	
<b>15.) Oil change</b>				
Drain oil from oil tank.	every 50 hr. <sup>(1)</sup>	X	12-20-00 sec. 11.2)	
Check the oil tank and clean the oil tank if contaminated.  <sup>(1)</sup> use of leaded fuel more than 30% of operation.	every 200 hr.	X <sup>(1)</sup>	12-20-00 11.5)	
Remove old oil filter from engine and install new oil filter.	every 50 hr. <sup>(1)</sup>	X	12-20-00 sec. 11.3)	
Cut old oil filter without producing any metal chips and inspect filter mat.  Findings: _____ _____	every 50 hr. <sup>(1)</sup>	X	12-20-00 sec.11.4)	

d05557.fm



**BRP-Powertrain**  
**MAINTENANCE MANUAL**

Points of Inspection	Interval Operating hours		Chapter Reference	Signature
	as indicated	100 hr.		
<p><b>Return to service</b></p> <p>At the identified engine (as per sec. 5), on (Date) _____ the _____ hr.            Check at _____ hr. (TSN____, TSO____) was carried out according to recommendations of the engine manufacturer and was recorded in the Engine Log book.</p> <p>Location, Date _____</p> <p>Inspector _____</p> <p>Aircraft mechanic _____</p> <p>Certificate No. _____</p>				

d05557.fm

**BRP-Powertrain**  
MAINTENANCE MANUAL

**Chapter: 05-50-00**

**UNSCHEDULED MAINTENANCE CHECKS**

**Introduction**

**NOTICE**

In the course of special checks specify if **additional checks** for components (e.g. hydraulic governor) is applicable.

After each special check/repair work, an engine test run and a leakage check must be carried out.

**NOTICE**

Observe without fail all the specified instructions.

Special checks must be carried out immediately in the event of an engine fault (e.g. abnormal operation as defined in the Operators Manual) which impairs the airworthiness of the engine.

**Table of contents**

This chapter of the Maintenance Manual contains general information regarding unscheduled maintenance checks and their associated procedures.

Subject	Page
Engine check after propeller strike incidents	<a href="#">page 3</a>
Propeller gearbox with integrated overload clutch	<a href="#">page 3</a>
Propeller gearbox without integrated overload clutch	<a href="#">page 4</a>
Checking of the overload clutch	<a href="#">page 5</a>
Examination after engine failure	<a href="#">page 7</a>
Returning engine to service after submerging in water	<a href="#">page 9</a>
Inspection in extreme climatic conditions	<a href="#">page 10</a>
Exceeding of max. admissible engine RPM	<a href="#">page 11</a>
Non compliance with the coolant specification	<a href="#">page 12</a>
Exceeding of max. cylinder head temperature	<a href="#">page 13</a>
Exceeding the max. permissible oil temperature	<a href="#">page 15</a>
Oil pressure below minimum value	<a href="#">page 17</a>
Oil specification not respected	<a href="#">page 19</a>
Spark plug not in accordance with specification	<a href="#">page 21</a>
Non compliance of fuel quality	<a href="#">page 21</a>
Smooth performance of the engine	<a href="#">page 22</a>
Reporting	<a href="#">page 23</a>

d055558.fm

**BRP-Powertrain**  
MAINTENANCE MANUAL

NOTES

d05558.fm

**BRP-Powertrain**  
MAINTENANCE MANUAL

## 1) Engine check after propeller strike incidents

**Definition** A propeller strike is:

- Any incident while the engine is stationary or running which makes it necessary to perform repairs on the propeller.

See SL-912-015, SL-914-012, SL-2ST-009, current edition.

---

### 1.1) Propeller gearbox with integrated overload clutch

**General note** After any propeller strike the following inspections must be performed before operation can continue.

Step	Procedure
1	Inspect the engine for damage. If any damage is detected, inspect, repair or overhaul the whole engine in accordance with the relevant Manual. Inspect all systems for correct functioning.
2	Inspect add-on components e.g. propeller governor, vacuum pump, external alternator. Observe the manufacturers instruction(s).
3	Observe the directives from the aircraft manufacturer.
4	Remove the fuel pump and gearbox.
5	Remove the roller bearing in crankcase for propeller shaft.
6	The whole gearbox must be inspected, repaired or overhauled in accordance with the BRP-Powertrain instructions for continued airworthiness - but not limited too <ul style="list-style-type: none"><li>- Carry out detailed inspection of all gearbox components.</li><li>- NDT for cracks on gearbox housing, propeller shaft and gear set.</li><li>- Inspect drive for governor and vacuum pump (if fitted).</li></ul>
7	Inspect the crankshaft on the power take off side for out-of roundness. See chapter 72-00-00 section 3.9) of the Heavy Maintenance Manual.
8	Re-install the gearbox.

---

d055558.fm

**BRP-Powertrain**  
MAINTENANCE MANUAL

**1.2) Propeller gearbox without integrated overload clutch**

**Propeller strike** The following inspections must be performed before operation can continue.

Step	Procedure
1	Inspect the engine for damage. If any damage is detected, inspect, repair or overhaul the whole engine in accordance with the BRP-Powertrain instructions for continued airworthiness. Inspect all systems for correct functioning.
2	Inspect add-on components.
3	Observe the directives of the aircraft manufacturer.
4	Remove the fuel pump.
5	Remove the gearbox and roller bearing of the propeller shaft.
6	The whole gearbox must be inspected, repaired or overhauled in accordance with the BRP-Powertrain instructions for continued airworthiness - but not limited too - Carry out detailed inspection of all gearbox components. - NDT for cracks on gearbox housing, propeller shaft and gear set. - Inspect drive for governor and vacuum pump (if fitted).
7	Observe the manufactures instructions for the governor, vacuum pump and propeller.
8	Inspect the crankshaft on the power take off side for out-of-roundness. Propeller shock load - Inspection of crankshaft distortion on installed crankshaft. See chapter 72-00-00 section. 3.9) of the Heavy Maintenance Manual.
9	Re-install the gearbox.

d05558.fm

## 2) Checking of the overload clutch

**General note** In the event of lead deposits and/or if slipping is suspected, it will be necessary to check the overload clutch.

**NOTES:** Slipping of overload clutch is apparent if at engine speed rise, the propeller speed does not increase at the same rate.

**NOTES:** The engine should be run for a short time just prior to the test, otherwise there is the risk of the clutch „drying out“, resulting in a higher torque.

Step	Procedure
1	Remove the propeller as per manufacturers instruction.
2	Lock the crankshaft. See chap. 12-20-00 section: 7)
3	<div style="background-color: #0056b3; color: white; padding: 5px; display: inline-block;"><b>NOTICE</b></div> Danger of damage to the engine suspension! Depending on the engine installation (e.g. in the case of extremely lightweight engine suspension), the gearbox must be removed and the test carried out on a suitable mounting attachment.  A specially prepared lever (e.g. length 1.5 m (4.92 ft.)), see Fig.1) is fitted on the propeller flange and the breakaway torque measured with a suitable measuring tool.  <b>NOTE:</b> Because of difficult measurement of the slipping torque the breakaway torque is measured.

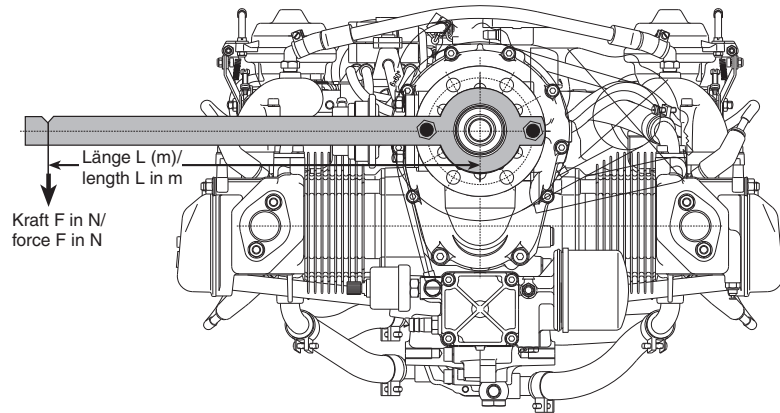

**Fig. 1**

08054

d05558.fm

# BRP-Powertrain

## MAINTENANCE MANUAL

**Measurement** Repeat the measurement several times to get a stable value.  
The breakaway torque is calculated on the basis of the force (F) measured in N and the length of the lever arm (L) used at the normal distance from it in m ( $N \times m = Nm$ ).

**Obtained value** **NOTICE** Do not exceed 800 Nm (590 ft.lb) otherwise gearbox damage can occur.

The value determined must be between 600 and 800 Nm (442 and 590 ft.lb.).

If the value is greater or smaller than the limit value, the overload clutch must be inspected, repaired or overhauled in accordance with the BRP-Powertrain instructions for continued airworthiness.

Step	Procedure
4	Release the crankshaft, see chap. 12-20-00 section: 7).

**BRP-Powertrain**  
MAINTENANCE MANUAL

### 3) Examination after engine failure

**General note** In order to find possible causes of the failure, it is important to pass on all available data. Observations on the aircraft and the engine suspension can also be of help. It is important to pay particular attention to any of the following engine phenomena to facilitate troubleshooting.

**Engine**

<b>Engine runs erratically and misfires</b>	
<b>part</b>	<b>possible cause</b>
Fuel system	fuel supply vapour locks contamination float chamber venting false air intake due to defective carburetor flange carburetor icing
Ignition system (shorting cable, electronic module, charging coil) Spark plug	malfunction grounding defect wrong spark plug connection

**Rough running**

<b>Rough running engine</b>	
<b>part</b>	<b>possible cause</b>
Ignition	wiring (assignment fault)
Carburetor	fuel supply contamination in float chamber or float needle valve float chamber venting false air intake due to defective carburetor flange incorrect synchronization of the carburetor
Engine	engine temperature too low too lean carburetor jetting due to conditions prevailing in intake silencer

**Engine stoppage**

**NOTICE**

Should one of the above mentioned points occur even for a short time then a detailed check of the engine is necessary. The fault needs to be located and corrected.

<b>Unintended engine stoppage by seizing</b>	
<b>part</b>	<b>possible cause</b>
Oil system	oil pressure too low or no oil pressure oil shortage contamination incorrect venting
Oil pump	defect

d05558.fm

**BRP-Powertrain**  
**MAINTENANCE MANUAL**

<b>Unintended engine stoppage by seizing</b>	
<b>part</b>	<b>possible cause</b>
Camshaft bearings/Conrod bearings	rather consequential damage wear (low oil pressure)
<div style="display: flex; align-items: center;"> <div style="background-color: #0056b3; color: white; padding: 5px; margin-right: 10px;"><b>NOTICE</b></div> <p>The entire assembly must be dismantled, inspected and repaired.</p> </div>	

- The whole engine must be inspected, repaired or overhauled in accordance with the BRP-Powertrain instructions for continued airworthiness.
- Inspect all systems for correct functioning.
- Detailed inspection of affected engine components.

**Cylinder head**

A rise in cylinder head temperature above normal operating limits (see Operators Manual) is a clear signal for a failure in the cooling system.

<b>Cylinder head temperature too high</b>	
<b>part</b>	<b>possible cause</b>
Cooling system	not enough coolant bad venting
Return valve is not working	malfunction
Radiator	contaminated
Radiator cap	leaking
Pressure relief valve	malfunction
Water pump	malfunction

### 3.1) Returning engine to service after submerging in water

**General note**

**NOTICE**

The engine must be marked clearly “Engine submerged in water“. Define whether fresh or salt water.

An engine which has been submerged in water must be inspected, repaired or overhauled in accordance with the BRP-Powertrain instructions for continued airworthiness.

- Inspect all systems for correct functioning.
  - Carry out detailed inspection of affected engine components.
-

### 3.2) Inspection in extreme climatic conditions

**General note**

**NOTICE**

Every 25 hr. checks of air filter, coolant radiator and oil cooler are necessary.

Flying in deserts or areas with heavily contaminated or dusty air causes increased wear on all components. For this reason, shorter maintenance intervals are recommended.

Flying in areas with extreme climatic conditions or in extreme altitudes requires adjustment of the carburetor jetting and of the cooling system. To do this, it is necessary to contact the aircraft manufacturer and an authorized ROTAX distributor.

---

### 3.3) Returning engine to service after influence by fire

**General note**

An engine after influence by fire must be inspected, repaired or overhauled in accordance with the BRP-Powertrain instructions for continued airworthiness. See therefore affected Maintenance Manual, latest issue.

---

**Inspection**

- Inspect all systems for correct functioning.

**NOTE:** Prior to the detailed inspection, all parts should be cleaned and inspected for weld penetration or melted materials.

If an engine was influenced by fire, first a visual inspection of all parts has to be done and then a hardness test of all mechanical parts must be performed (e. g.: crankcase, cylinder, cylinder heads etc.).

In most cases an overhaul is necessary, in this regard send the engine without delay to an authorized ROTAX overhaul facility for inspection.

---

**BRP-Powertrain**  
MAINTENANCE MANUAL

### 3.4) Exceeding of max. admissible engine RPM

**General note**

**NOTICE**

Any exceeding of the max. admissible engine RPM must be entered by the pilot into the engine log book stating duration extent of overspeeding and pertinent detail.

**5800 rpm up to max. 6200 rpm**

**If the limit was exceeded for max. 1 minute and max. 6200 rpm**

Step	Procedure
1	No action needed.

**5800 rpm up to max. 6200 rpm**

**If the limit was exceeded for more than 1 minute and max. 6200 rpm**

Step	Procedure
1	Check that the push-rods are straight.

**6200 rpm up to max. 6500 rpm**

**If the limit was exceeded for max. 1 minute and max. 6500 rpm**

Step	Procedure
1	Check that the push-rods are straight.

**6200 rpm up to max. 6500 rpm**

**If the limit was exceeded for more than 1 minute and max. 6500 rpm**

Step	Procedure
1	The whole engine must be inspected, repaired or overhauled in accordance with the BRP-Powertrain instructions for continued airworthiness.
2	Check that the push-rods are straight.
3	Inspect the crankshaft for out-of-roundness. See chapter 72-00-00 section 3.9) of the Heavy Maintenance Manual.
4	Inspect all systems for correct functioning.
5	Detailed inspection of affected engine components.

**more than 6500 rpm**

**If the speed of 6500 rpm was exceeded**

Step	Procedure
1	The whole engine must be inspected, repaired or overhauled in accordance with the BRP-Powertrain instructions for continued airworthiness.
2	Check that the push-rods are straight.
3	Check differential pressure.
4	Inspect crankshaft with mounted drive gear for runout and distortion. See chap. 72-00-00 section 3.9) and 3.18) of the Heavy Maintenance Manual.
5	Check if piston had contact with valve.
6	Check roundness of valves.

d05558.fm

**BRP-Powertrain**  
MAINTENANCE MANUAL

Step	Procedure
7	Inspect all systems for correct functioning.
8	Detailed inspection of affected engine components.

### 3.5) Non compliance with the coolant specification

**General note**

**NOTICE**

Use only coolant as recommended in the current Operators Manual and SI-912-016 “Selection of suitable operation fluids“, current issue.

Non compliance with the coolant specification	
Step	Procedure
1	When a different coolant as the former one (conventional coolant) is used, then the coolant system has to be flushed. See chapt. 12-20-00 section: <a href="#">9.3</a> )
2	Fill in with new coolant See chapt. 12-10-00 section: <a href="#">3.1</a> ).
3	Re-install the radiator cap.
4	NOTE: Run engine for a minute and replenish as required.

d05558.fm

### 3.6) Exceeding of max. cylinder head temperature

General note

**NOTICE**

If the maximum cylinder head temperature is exceeded, other limits are also often exceeded, e.g. oil temperature. Please observe the relevant instructions.

NOTES:

Any exceeding of the max. admissible cylinder head temperature must be entered by the pilot into the engine log book, stating duration extent of excess temperature and pertinent detail.

Graphic

Overview and proceed:

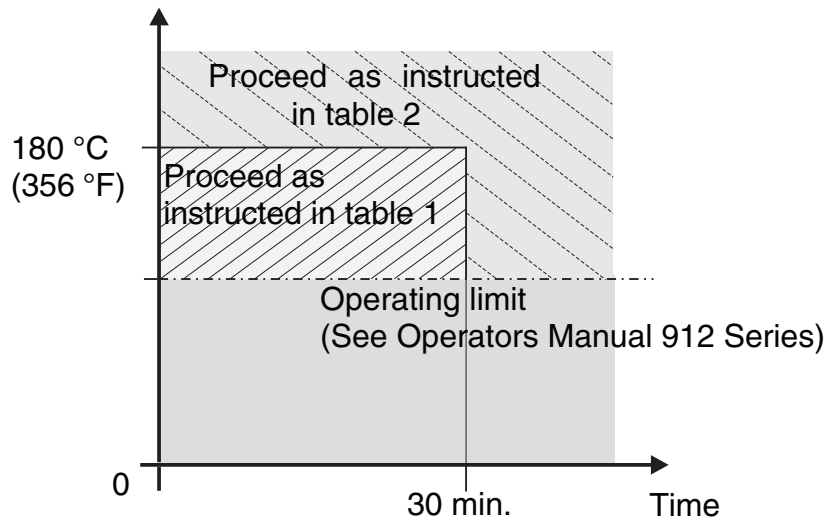

Fig. 2

07140

Exceeding up to 180 °C

Table 1.

Exceeding up to 180 °C (356 °F)- short-term	
Step	Procedure
1	The whole cooling system must be inspected, repaired or overhauled in accordance with the BRP-Powertrain instructions for continued airworthiness.
2	Inspect all further systems for correct functioning.
	Carry out detailed inspection of the affected engine components such as. <ul style="list-style-type: none"> <li>- Leakage check on the cooling system.</li> <li>- Check that the cylinder head attachment is fitted securely. If the cylinder head nut is loose, proceed as instructed in sec. "Excess temperature of over 180 °C (356 °F) and/or for longer than 30 min."</li> <li>- Check all coolant fittings (feed/outflow) for secure fit.</li> </ul>

d05558.fm

**BRP-Powertrain**  
MAINTENANCE MANUAL

Exceeding  
over 180 °C

Table 2.

<b>Excess temperature of over 180 °C (356 °F) and/or for longer than 30 min.</b>	
<b>Step</b>	<b>Procedure</b>
1	The whole cooling system must be inspected, repaired or overhauled in accordance with the BRP-Powertrain instructions for continued airworthiness.
2	Inspect all further systems for correct functioning.
3	Carry out detailed inspection of the affected engine components.
4	Check compression by carrying out a differential pressure check.
5	All cylinder heads and cylinders must be removed and subjected to a detailed check including hardness testing. See chap. 72-00-00 in the Heavy Maintenance Manual.

### 3.7) Exceeding the max. permissible oil temperature

General note

**NOTICE**

If the max. permissible oil temperature is exceeded, other limits are often exceeded, too, e.g. the cylinder head temperature. Please observe the relevant instructions.

NOTES:

Any exceeding of the max. admissible oil temperature must be entered by the pilot into the engine log book, stating duration extant of excessive temperature and pertinent detail.

Graphic

Overview and proceed;

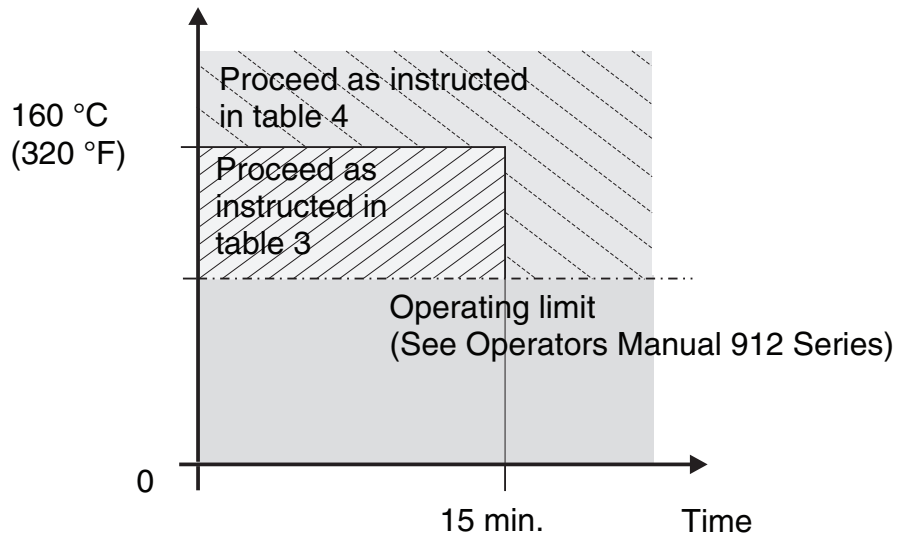

Fig. 3

07140

Exceeding up to max. 160 °C (320 °F)

Table 3.

Excess temperature up to max. 160 °C (320 °F) max. 15 min.	
Step	Procedure
1	The whole oil system must be inspected, repaired or overhauled in accordance with the BRP-Powertrain instructions for continued airworthiness.
2	Inspect oil level in the oil tank.
3	Inspect oil cooler for contamination and check the entire oil circuit for correct functioning.
4	Check that oil lines are routed correctly and undamaged.
5	Cut oil filter housing and inspect filter mat for foreign matter.
6	Carry out oil change.
7	Inspect all further systems for correct functioning.

d05558.fm

**BRP-Powertrain**  
MAINTENANCE MANUAL

Exceeding over  
160 °C (320 °F)

Table 4.

Excess temperature over 160 °C (320 °F) for longer than 15 min.	
Step	Procedure
1	The whole engine must be inspected, repaired or overhauled in accordance with the BRP-Powertrain instructions for continued airworthiness.
2	Inspect all further systems for correct functioning.
3	Carry out detailed inspection of the affected engine components.
4	The whole oil system (oil cooler, oil lines) must be inspected.
5	Cut oil filter housing and inspect filter mat for foreign matter.
6	Carry out oil change.

### 3.8) Oil pressure below minimum value

General note

**NOTICE**

If the oil pressure falls below the minimum value, other limits are often exceeded, e.g. the oil temperature. Please observe the relevant instructions.

NOTES:

Any exceeding of the min. admissible oil pressure must be entered by the pilot into the engine log book, stating duration extent of excessive pressure and pertinent details.

Graphic

Overview and instruction

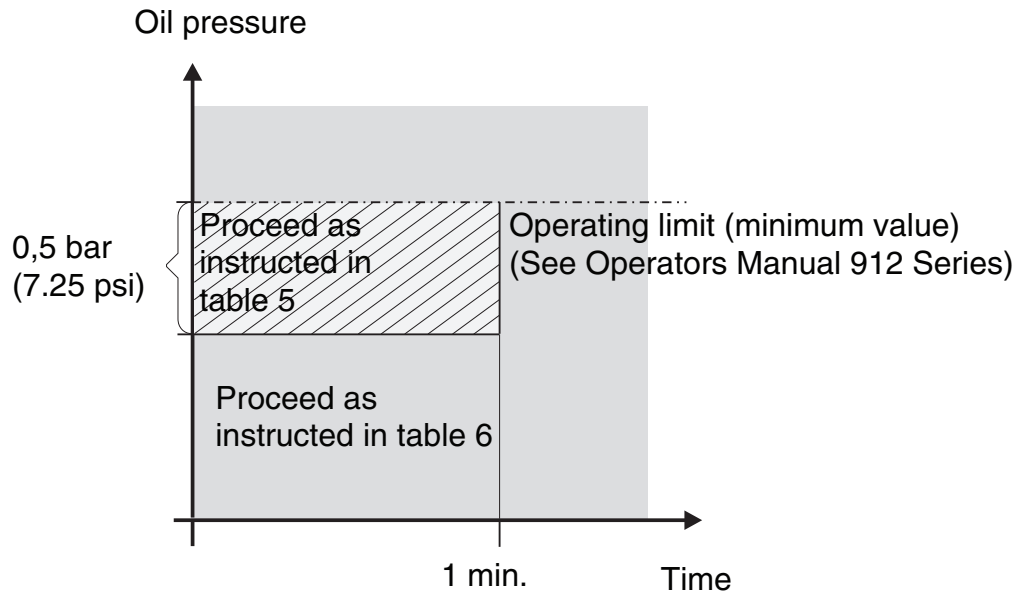

Fig. 4

07188

Minimum oil pressure on the ground

#### Oil pressure below minimum oil pressure on the ground

If noticed **on ground**, immediately stop the engine and determine the cause.

- Inspect the complete lubrication system, trace cause and rectify. See SI-912-005, latest issue.

d055558.fm

# BRP-Powertrain

## MAINTENANCE MANUAL

**Minimum oil pressure falls below 0.5 bar (7.25 psi) max. 1 min. in flight**

If the oil pressure falls below the minimum value up to max. 0,5 bar (7.25 psi) and for max. 1 min., the cause must be determined. Table 5.

Oil pressure below minimum permissible oil pressure up to max. 0.5 bar (7.25 psi) max. 1min. in flight	
Step	Procedure
1	Inspect all oil lines for restrictions and clear passage.
2	Verify oil quantity.
3	Inspect pressure sensor.
4	Inspect indicating instrument to specifications of the manufacturer, replace as required.
5	Inspect crankcase pressure (See Installation Manual 912 Series, latest issue.)
6	If no cause for the low oil pressure is found after the above checks, carry out an oil change.
7	If after the previous checks and oil change the oil pressure is still too low, repair or overhaul the engine in accordance with the BRP-Powertrain instructions for continued airworthiness.
8	Inspect all systems for correct functioning.
9	Carry out detailed inspection of the affected engine components.

### NOTICE

Replace the oil cooler and oil lines. Before the reinstallation of the engine the complete lubrication system (inclusive oil tank) must be flushed.

**Minimum oil pressure in flight more then 0.5 bar (7.25 psi)**

Consequent damage can be expected if the oil pressure falls below the minimum value more than 0.5 bar (7.25 psi). Table 6.

Oil pressure below minimum permissible value more than 0.5 bar (7.25 psi) in flight	
Step	Procedure
1	The whole cooling system must be inspected, repaired or overhauled in accordance with the BRP-Powertrain instructions for continued airworthiness. - Replace the crankshaft.
2	Carry out detailed inspection of the affected engine components.
3	Cut oil filter housing and inspect filter mat for foreign matter.
4	Inspect all further systems for correct functioning.

d05558.fm

**BRP-Powertrain**  
MAINTENANCE MANUAL

**3.9) Oil specification not respected**

General note

NOTES: An entry by the pilot in the engine log book of all pertinent details is required.

If by error engine was serviced with oil, which does not correspond with oil specification in the Operators Manual and the engine has been in operation for **less than 5 hours**, the following measures must be taken:

less than 5 hr.

Oil specification not respected	
Step	Procedure
1	Oil change.
2	Remove the lowest positioned banjo screw (1) (banjo bolt, plug screw or screw socket) and drain the remaining oil from the crankcase. Screw in banjo bolt or plug screw. Tightening torque see Installation Manual 912 Series.
3	Replace oil filter.
4	Drain oil completely from oil cooler.
5	Drain oil from oil tank.
6	Refill oil tank with oil as specified, refer to Operators Manual.
7	Purge air from oil system. See chap. 12-20-00, section: 11.6).
8	Run engine for approx. 1 hour and replace oil and oil filter once more, as stated above.

Graphic

Position of the plug screw or banjo bolt

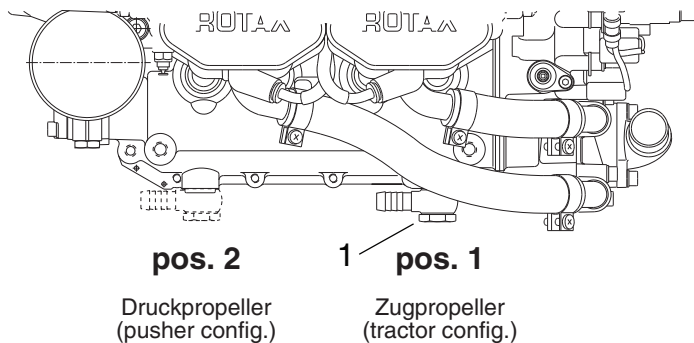

Part	Function
1	banjo bolt

Fig. 5

02712

d05558.fm

# BRP-Powertrain

## MAINTENANCE MANUAL

**longer than 5 hr.** If the engine has been operated **longer than 5 hours** with engine oil not corresponding with specification in the Operators Manual the following work is required.

Oil specification not respected	
Step	Procedure
1	Remove propeller gearbox.
2	The gearbox must be inspected, repaired or overhauled in accordance with the BRP-Powertrain instructions for continued airworthiness.
3	Carry out detailed inspection of the affected engine components.
4	Oil change.
5	Remove the lowest positioned banjo screw (1) (banjo bolt, plug screw or screw socket) and drain the remaining oil from the crankcase. Screw in banjo bolt or plug screw. Tightening torque see Installation Manual 912 Series.
6	Replace oil filter.
7	Check contact surfaces camshaft/hydraulic tappet.
8	Drain oil completely from oil cooler.
9	Drain oil from oil tank.
10	Refill oil tank with oil as specified, refer to Operators Manual.
11	Purge air from oil system. See chap. 12-20-00, section: <a href="#">11.6</a> ).
12	Run engine for approx. 1 hour and replace oil and oil filter once more, as stated above.

d05558.fm

**BRP-Powertrain**  
MAINTENANCE MANUAL

### 3.10) Spark plug not in accordance with specification

**General note** If by error any of the spark plugs were installed which are not according to specification of the engine manufacturer and/or not genuine ROTAX parts, the following verification will be necessary.

Spark plug not in accordance with specification	
Step	Procedure
1	Mark position of the spark plugs (e.g. cyl. 1 top) and remove all spark plugs.
2	Inspect the spark plugs for damage (formation of melt beads, burn off). At heavy melt beads or bad burn off, inspect the piston dome and cylinder wall by borescope. If parts are damaged, the engine must be inspected, repaired or overhauled in accordance with the BRP-Powertrain instructions for continued airworthiness.
3	Inspect all systems for correct function.
4	Detailed inspection of affected engine components.
5	Inspect spark plug thread for damage (especially at bad burn off).
6	Differential pressure check. See chap. 12-20-00 section: 5).
7	Change oil and oil filter.

### 3.11) Non compliance of fuel quality

**General note** The use of unsuitable fuel quality has to be entered in the engine log book.

Non compliance with fuel quality	
Step	Procedure
1	Visual inspection of engine
2	Empty the fuel system according to the instructions of cell manufacturer
3	Replace fuel filter
4	Flush fuel system
5	Check differential pressure
6	Engine test run

d05558.fm

### 3.12) Smooth performance of the engine

General note See Fig. 6.



**WARNING**

Risk of electric shock!  
 Ignition "OFF" and system grounded! Disconnect negative terminal of aircraft battery.

Inspection Carry out inspection at a temperature from 0° C up to 60° C (140 °F).

Engine runs sluggishly	
Step	Procedure
1	Remove spark plug connector and remove 1 spark plug from each cylinder.
2	Torque must be determined with a suitable jig. To do this, determine the maximum occurring torque on the propeller shaft necessary to move the whole crank drive. The torque must be max. 150 Nm (110.64 ft.lb). If the max. permissible torque is exceeded, following inspections are to be performed: - Carry out detailed inspection of the affected gearbox components - Carry out detailed inspection of crank driv

Graphic

Measuring torque required to turn crank drive

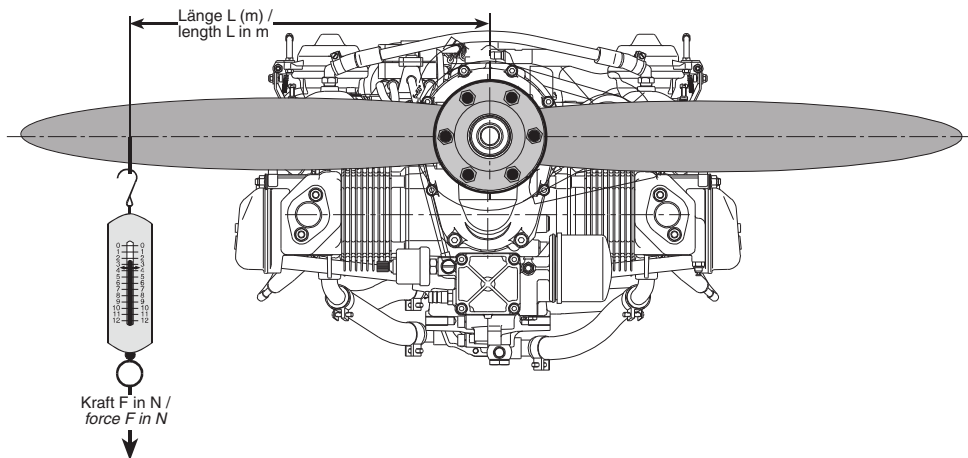

NOTES: Always use a propeller guard (edge protection) when performing this inspection.

Fig. 6

05694

**BRP-Powertrain**  
MAINTENANCE MANUAL

**3.13) Reporting**

**General note**

According to the regulation of EASA part 21A.3 / FAR 21.3 the manufacturer shall evaluate field information and report to the authority. In case of any relevant occurrences that may involve malfunction of the engine, the form on the next page should be filled out and sent to the responsible authorized ROTAX distributor.

NOTES: The form is also available from the official ROTAX AIR-CRAFT ENGINES Homepage in electronic version.

**[www.FLYROTAX.com](http://www.FLYROTAX.com)**

Register: **Document type/Miscellaneous**

---

d055558.fm

**BRP-Powertrain**  
MAINTENANCE MANUAL

NOTES

d05558.fm

# BRP-Powertrain MAINTENANCE MANUAL

Form

d05558.fm

 <b>CUSTOMER SERVICE INFORMATION REPORT</b>		<b>OPER. Control No.</b>	
		<b>ATA Code</b>	
		<b>1. A/C Reg. No.</b>	
Enter pertinent data	<b>MANUFACTURER</b>	<b>MODEL/SERIES</b>	<b>SERIAL NUMBER</b>
<b>2. AIRCRAFT</b>			
<b>3. POWERPLANT</b>	ROTAX		
<b>4. PROPELLER</b>			
<b>5. SPECIFIC PART (of component) CAUSING TROUBLE</b>			
Part Name	MFG. Model or Part No.	Serial No.	Part/Defect Location
<b>6. ENGINE COMPONENT (Assembly that includes part)</b>			
Engine/Comp. Name	Manufacturer	Model or Part No.	Serial Number
Engine TSN	Engine TSO	Engine Condition	7. Date Sub.

8. Comments (Describe the malfunction or defect and the circumstances under which it occurred. State probable cause and recommendations to prevent recurrence.)

OPERATOR DESIGNATOR								
DISTRICT OFFICE	<input type="checkbox"/> OTHER	<input type="checkbox"/> COMPUTER	<input type="checkbox"/> ACG	<input type="checkbox"/> MFG	<input type="checkbox"/> AIR TAXI	<input type="checkbox"/> MECH	<input type="checkbox"/> OPER	<input type="checkbox"/> REP. STA
SUBMITTED BY: _____								
TELEPHONE NUMBER: ( _____ ) _____								

**Optional Information:**  
Check a box below, if this report is related to an aircraft

Accident; Date \_\_\_\_\_  Incident; Date \_\_\_\_\_

**BRP-Powertrain**  
MAINTENANCE MANUAL

NOTES

d05558.fm

**BRP-Powertrain**  
MAINTENANCE MANUAL

**Chapter: 12-00-00**  
**MAINTENANCE OF THE SYSTEMS**

**Introduction**

The section “Maintenance of the systems“ is associated with other sections. It serves only as a supplement to and further explanation of the maintenance check list (See 05-20-00).

NOTES: For reasons of clarity, only headlines and keywords are listed in the Maintenance Schedule. Please refer to the following pages for further explanation if needed.

As far as possible, the content has been arranged according to system.

---

**Table of contents**

This chapter of the Maintenance Manual contains the most common maintenance procedures.

Subject	Chapter
Introduction	<a href="#">12-00-00</a>
Replenishing operating fluids	<a href="#">12-10-00</a>
Scheduled maintenance	<a href="#">12-20-00</a>

---

**BRP-Powertrain**  
MAINTENANCE MANUAL

NOTES

d05559.fm

**Chapter: 12-10-00**  
**REPLENISHING OPERATING FLUIDS**

**Introduction** The engine should always be in a horizontal position before checking the fill levels.

**ENVIRONMENT NOTE**

All operating materials and cleaning products endanger the environment by improper disposal.  
Dispose of the operating materials in an environmentally sound way!

**Table of contents** This chapter covers the steps required to replenish all operating fluids on the engine and also provides an overview of the fill capacities.

Subject	Page
General note	<a href="#">page 3</a>
Fluid capacities	<a href="#">page 5</a>
Cooling system	<a href="#">page 7</a>
Coolant check/replenish	<a href="#">page 7</a>
Lubrication system	<a href="#">page 9</a>
Oil level check/replenish	<a href="#">page 9</a>

**BRP-Powertrain**  
MAINTENANCE MANUAL

NOTES

**BRP-Powertrain**  
MAINTENANCE MANUAL

**1) General**

**Servicing points  
on the engine**

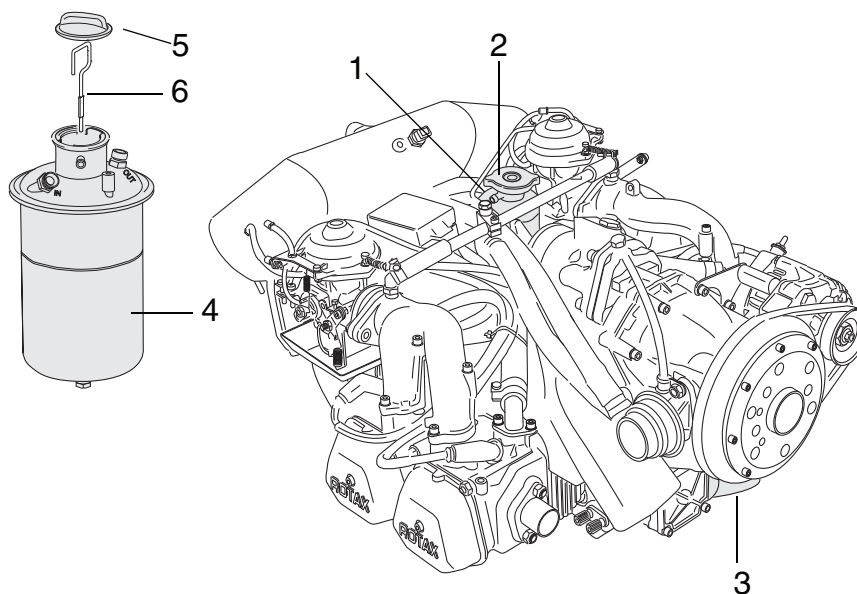

Part	Function
1	Expansion tank
2	Radiator cap
3	Oil filter
4	Oil tank
5	Oil tank cover
6	Oil dipstick

*Fig. 1*

08522

d05560.fm

**BRP-Powertrain**  
MAINTENANCE MANUAL

NOTES

**BRP-Powertrain**  
MAINTENANCE MANUAL

## 2) Fluid capacities

General note

**NOTICE**

The operation of the engine may be adversely affected if non-approved or contaminated fuel, oil or coolant are used. Any mixing of different manufacturers and types should be avoided. The use of additives may result in damage.

System

Overview

System	Fill capacity	Details about the operating fluids
Fuel system	Refer to the relevant specifications provided by the aircraft manufacturer	Refer to the corresponding chapter in the Flight Manual
Cooling system	approx. 1.5 l (0.4 US gal.)	Refer to the corresponding chapter in the Installation Manual
Oil system	MIN mark corresponds to 2.5 l (0.66 US gal.) and MAX mark corresponds to 3.0 l (0.8 US gal.)	Refer to the corresponding chapter in the Installation Manual

d05560.fm

**BRP-Powertrain**  
MAINTENANCE MANUAL

NOTES

### 3) Cooling system

#### 3.1) Coolant check/replenish

**General note**



Risk of Burns!  
Hot engine parts!  
Always allow engine to cool down to ambient temperature before start of any work.



Risk of Burns!  
Never open the radiator cap when the cooling system is hot. For safety's sake, cover cap with a rag and open slowly. Sudden opening of the cap could provoke the escape of boiling coolant and result in scalding.

**ENVIRONMENT NOTE**

Coolant and mixtures of coolant and water have to be treated as hazardous waste!

**Instruction**

See [Fig. 3](#).

To refill the coolant the following steps are necessary.

Step	Procedure
1	Open the radiator cap (1) on the expansion tank (2).
2	Check the coolant level. The coolant level must be filled up to the top (see Sketch).
3	Inspect coolant with densimeter or glycol tester. Strongly discolored or thickened coolant must be replaced.
4	<div style="display: flex; align-items: center;"> <div style="background-color: #0056b3; color: white; padding: 2px 5px; margin-right: 5px;"><b>NOTICE</b></div> <div>Use only coolant as recommended in the current Operators Manual.</div> </div> <p>If necessary, replenish with coolant of same composition.</p>
5	<p>Tighten the radiator cap by hand.</p> <p>NOTE: The radiator cap must be tightened until the stop lug is contacted.</p>

**Special tools**

For accomplishment the following special tool is required.

Part number	Description
n.a.	(1) Densimeter
n.a.	(2) Glycol tester

d05560.fm

# BRP-Powertrain

## MAINTENANCE MANUAL

Graphic

Special tool



Fig. 2

05908,05909

Engine test run

Engine test run is necessary:

Step	Procedure
1	Operate the engine until the temperatures have stabilized for a period of 5 min. (engine oil temperature between 50 to 70 °C (122 - 160 °F).
2	Switch the engine OFF.
3	Allow the engine to cool down.
4	Check for leaks.
5	Check the coolant level and top up with coolant as required.

Graphic

Coolant check/replenish

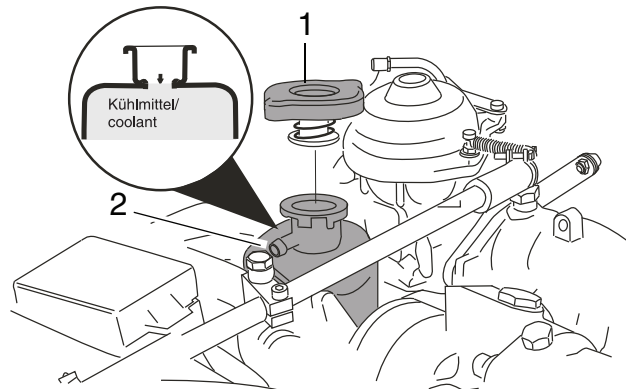

Part	Function
1	Radiator cap
2	Expansion tank

Fig. 3

08523

d05560.fm

## 4) Lubrication system

### 4.1) Oil level check/Replenish

**General note**



Risk of Burns!  
Hot engine parts!  
Always allow engine to cool down to ambient temperature before start of any work.



Risk of electric shock!  
Ignition "OFF" and system grounded! Disconnect negative terminal of aircraft battery.

**ENVIRONMENT NOTE**

Be careful that no oil enters the sewerage system or the soil -  
Risk of contamination of drinking water!  
Collect waste oil and take it to the recycling center.

**Preparatory tasks**

Before checking the oil level, make sure that there is not excess residue oil in the crankcase.

**Instruction**

See [Fig. 4.](#)

For checking and before replenish proceed as follows.

Step	Procedure
1	Prior to oil level check, turn the propeller several times by hand in direction of engine rotation to pump all the oil from the engine to the oil tank.
2	This process is completed when air flows back to the oil tank. This air flow can be perceived as a murmur (gurgling) when the oil tank cover (1) of the oil tank is removed.
3	Pull out the oil dipstick (2).
4	The oil level in the oil tank should be between the two marks (max./min.) on the oil dipstick, but must never fall below the min. mark. See Service Bulletin SB-912-040, "Introduction of a new oil dipstick", latest issue.
5	<div style="display: flex; align-items: flex-start;"> <div style="background-color: #0056b3; color: white; padding: 5px; margin-right: 10px;"><b>NOTICE</b></div> <div> <p>For longer flights replenish oil to max. mark to warrant more oil reserve.</p> <p>During standard engine operation, the oil level should be mid-way between the max. and min. marks, as at higher oil level (over servicing), oil will escape via the venting passage see also SI-27-1997, "oil level check", latest issue. Difference between "max." and "min". - mark = 0,45 l (0.95 liq.pt)</p> </div> </div>
6	<p>Replenish oil as required.</p> <div style="display: flex; align-items: flex-start;"> <div style="background-color: #0056b3; color: white; padding: 5px; margin-right: 10px;"><b>NOTICE</b></div> <div> <p>Only use brand name oil in accordance with the latest Operators Manual and SI-912-016, "Selection of suitable operating fluids" latest issue.</p> </div> </div>

d05560.fm

**BRP-Powertrain**  
**MAINTENANCE MANUAL**

Step	Procedure
7	Check oil level - Marks on the oil dipstick.
8	Fit the oil dipstick and tighten the oil tank cover (1) by hand.

**Engine test run** Engine test run is necessary:

Step	Procedure
1	Operate the engine until the temperatures have stabilized for a period of 5 min (engine oil temperature between 50 to 70 °C (122 - 160 °F).
2	Switch the engine OFF.
3	Allow the engine to cool down.
4	Check for leaks.
5	Check the oil level and top up with oil as required.

**Graphic** Oil level check/Replenish

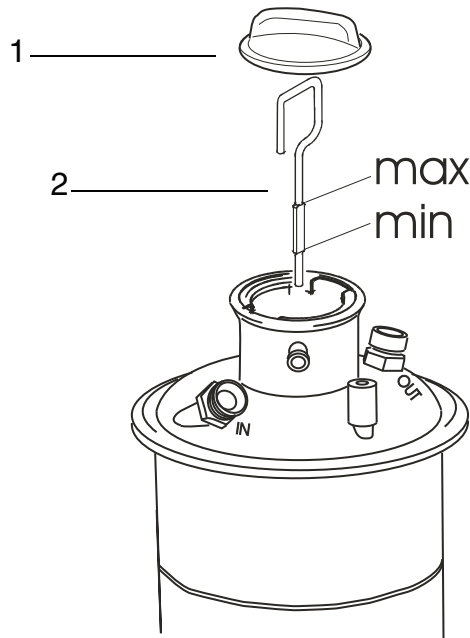

Part	Function
1	Oil tank cover
2	Oil dipstick

*Fig. 4*

08524

d05560.fm

**BRP-Powertrain**  
MAINTENANCE MANUAL

**Chapter: 12-20-00**  
**SCHEDULED MAINTENANCE**

**Introduction** This chapter relates in particular to the maintenance work mentioned in the Maintenance Schedule for the various engine systems and covers the work in more detail.

**Table of contents** This chapter contains information which is required to perform scheduled servicing on the engine.

Subject	Page
Introduction	page 1
Engine cleaning	page 3
Checking the air filter	page 5
Cleaning the air filter	page 5
Replacing the air filter	page 7
Visual inspection	page 9
Checking the engine suspension	page 9
Corrosion	page 10
Leakage check	page 11
Checking the compression	page 13
Checking the compression for fault-tracing	page 15
Checking the V-belt tension	page 17
Locking the crankshaft	page 19
Test run of engine	page 21
Cooling system	page 23
Checking the cool system	page 23
Replacing the coolant	page 24
Flushing the cooling system	page 26
Expansion tank, Radiator cap	page 27
Overflow bottle	page 29
Accessories	page 29
Fuel system	page 31
Carburetor synchronization	page 31
Mechanical synchronization	page 32
Pneumatic synchronization	page 34
Idle speed check	page 38
Operating range check	page 39
Checking of the float chamber	page 41
Idle speed adjustment	page 43
Checking the carburetor actuation	page 44

d055661.fm

**BRP-Powertrain**  
MAINTENANCE MANUAL

Subject	Page
Lubrication system	page 47
Oil change	page 49
Oil filter replacement	page 50
Install oil filter	page 50
Inspection of the oil filter insert	page 52
Cleaning the oil tank	page 54
Purging the oil system	page 56
Flushing the oil circuit	page 56
Inspecting the magnetic plug	page 59
Installation of the magnetic plug	page 60
Electric system	page 61
Check of wiring	page 62
Inspection and replacement of spark plugs	page 63
Installation of spark plug	page 65
Propeller gearbox	page 67
Checking the friction torque in free rotation	page 67
Checking the propeller gearbox	page 68

## 1) Engine cleaning

### General note

#### **ENVIRONMENT NOTE**

When cleaning the engine, the dissolved residues of fuel, oil and other environment-contaminating agents are rinsed off. Collect the residual liquids and dispose of it in an environmentally sound way

#### **NOTICE**

Do not use easily inflammable liquids or caustic cleaning agents for cleaning the engine.

### Cleaning agents

Use of a commercially available cold cleaning agent for the engine is recommended. See chap. 05-00-00 section: [1.5](#)).

### Cleaning

#### **NOTICE**

Never clean an engine with a high pressure cleaner. This is detrimental to the electrical installations and shaft seals. Oxidation of the various components and their failure are the consequence.

#### **NOTICE**

Before cleaning, all openings through which cleaning agents and/or dirty water could enter the engine must be closed off. Failure to do this may result in engine damage!

NOTES: Always clean engine in cold state.

If necessary, the engine must be cleaned with due care. Repair leaks as required before cleaning.

### After each cleaning

After each cleaning procedure, dry all electrical components such as

- Battery
- Ignition unit
- Spark plug connector
- Clamp connections etc.
- Plug connections etc.

by use of compressed air to prevent leakage current.

**BRP-Powertrain**  
MAINTENANCE MANUAL

NOTES

d05561.fm

## 2) Checking air filter

General note

**NOTICE**

In the event of dust formation, clean air filter at correspondingly shorter intervals. If filter mat is damaged, replace air filter.

**NOTICE**

A dirty filter insert will not only reduce the engine performance but might also promote premature wear of the engine.

Carry out visual inspection of air filter after prescribed maintenance interval. Clean dirty air filter as described in aircraft manufacturers Maintenance Manual.

---

### 2.1) Cleaning the air filter

General note

**NOTICE**

Never use gasoline, steam, caustic liquids, strong detergents, particle cleaning agents or high pressure cleaners during this step.

**NOTICE**

Do not dry over naked flame, with compressed air or with hot air gun.

---

Cleaning

To clean the air filter the following steps are necessary:  
See [Fig. 1](#) and [Fig. 2](#).

NOTES: The procedure for cleaning air filter applies to the K&N style filter supplied by ROTAX (BRP-Powertrain) but may vary for filters used by aircraft manufacturer.

Step	Procedure
1	Lightly tap and brush off surface dirt (A).
2	Spray K&N filter cleaner onto filter surface and leave to soak for approx. 10 min. (B).
3	Rinse air filter with low pressure water from inside to outside and let element dry naturally (C).

---

**BRP-Powertrain**  
MAINTENANCE MANUAL

Graphic

Cleaning of the filter

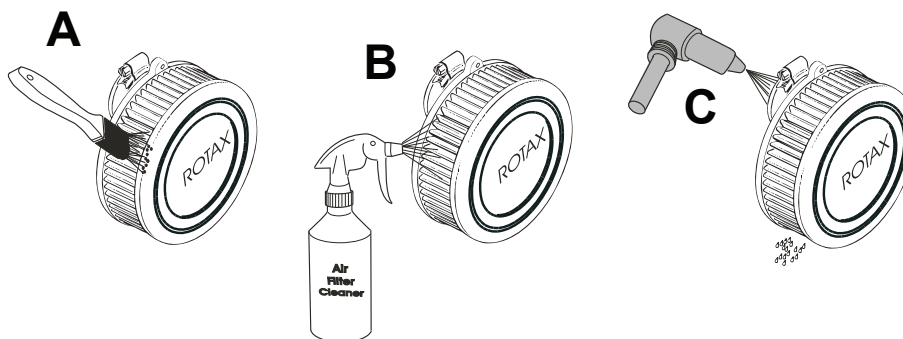

*Fig. 1*

08525

After cleaning

**NOTICE**

Never use gear oil, diesel or engine oil, as they attract humidity.

NOTES: Each filter pleat must be sprayed with oil.  
After 5 to 10 min. the filter will be soaked with oil, noticeable by the uniform red coloring.

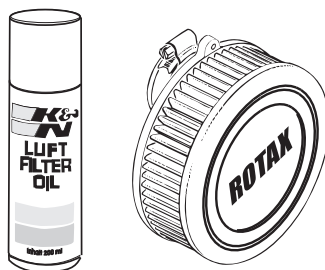

*Fig. 2*

08526

## 2.2) Replacing the air filter

General note See Fig. 3.

**NOTICE**

Each air filter must be secured by clamp attachment and a wire securing element. See chap. 05-00-00 section: 1.6). Filter connection must be free of oil.

**NOTICE**

Attach new air filter, free of grease, at connection faces, and wire-secure against loss.

Graphic

Only use dry type air filters which are specified by the aircraft manufacturer and from ROTAX.

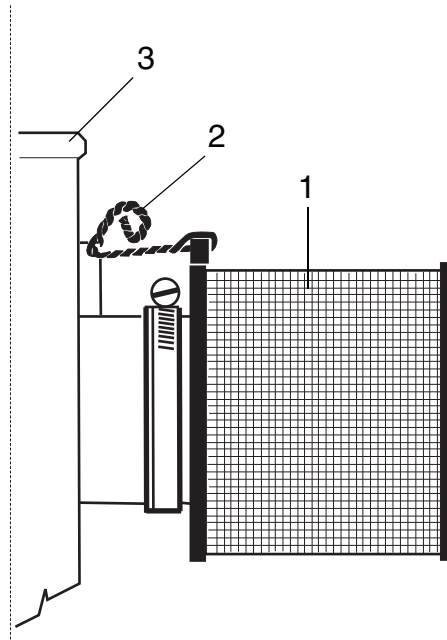

Part	Function
1	Air filter
2	Safety wire
3	Carburetor

Fig. 3

08527

d05561.fm

**BRP-Powertrain**  
MAINTENANCE MANUAL

NOTES

d05561.fm

### 3) Visual inspection

**General note** General visual inspection of the engine for damage or abnormalities. For definition and scope of visual inspection (See chap. 05-20-00 section: **3**).

- Abnormalities** Take note of changes caused by temperature influence.
- During a visual inspection you should focus on the following points in particular:
- Exhaust system
  - Airbox
  - Engine suspension frame
  - Heat shrink sleeve
  - Oil cooler
  - Venting hoses (oil tank)
  - Fuel lines
  - Cooler
  - Coolant hoses

#### 3.1) Checking the engine suspension

**General note** **NOTICE** Exactly observe the tightening torques for screws and nuts. Overtightening or too loose connection could cause serious engine damage.

**Checking the engine suspension**

Step	Procedure
1	Inspect the engine suspension points on the crankcase for tight fit and damage including cracks.
2	Inspect the surroundings of engine attachment on crankcase and gearbox. If there is discoloration of the crankcase around the attachment points (black ring), there may be loose attachments.
3	Inspect engine isolating mounts for heat damage, wear and cracks.
4	Visual inspection of the engine suspension frame for cracks.

d055661.fm

**BRP-Powertrain**  
MAINTENANCE MANUAL

**3.2) Corrosion**

**Definition**

Corrosion is a natural process which attacks and potentially damages metals via an electro-chemical reaction. For more detailed information about different types of corrosion and corresponding methods for dealing with corrosion refer to the FAA Advisory Circular AC 43.13. See chapter “AC 43.13-1B Maintenance and Repair”.

---

**BRP-Powertrain**  
MAINTENANCE MANUAL

#### 4) Leakage check

General note

**NOTICE**

Leaking connections can lead to engine problems or engine failure!

Visual inspection of the whole engine for leaks. If leaks are visible, locate the cause and remedy the fault.

Instruction

NOTES: If a leak is suspected, then the following check is possible:

Step	Procedure
1	Cleaning the engine.
2	Operate the engine until the temperatures have stabilized for a period of 5 min (engine oil temperature between 50 to 70 °C (122 - 160 °F)).
3	Switch off ignition and secure engine against unintentional operation. Secure aircraft against unauthorized operation.
4	For a period of 1 minute after the engine has been stopped, no liquid must drip down.

Water pump

Checking water pump for leaks.

If the leakage bore, located at the base of the ignition housing, is dripping oil, the oil seal on the water pump shaft may be defective and must be replaced. In the case of coolant drips at the leakage bore, the coolant mechanical seal must be replaced (inspect the quality of the coolant).

Fuel lines

Inspect fuel lines, their connections and screw fasteners. Look for scuffing marks.

**NOTICE**

Avoid overstretching the fixing elements. Always comply with the specified torque!

Detailed visual inspection specially on steel fuel lines in the area of connections (fittings) (2) for leaks and cracks is necessary. See [Fig. 4](#).

d055661.fm

**BRP-Powertrain**  
**MAINTENANCE MANUAL**

**Graphic**

**Connections and fuel lines**

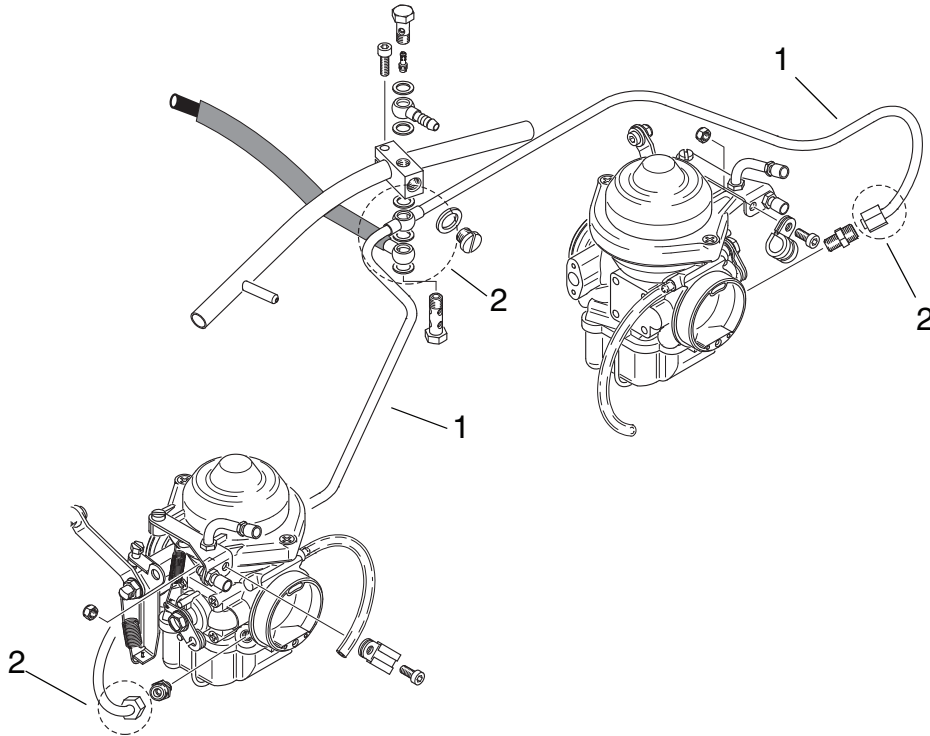

Part	Functions
1	Fuel lines (Steel)
2	Connections (Fittings)

*Fig. 4*

09034

**Fuel pump**

Inspect fuel pump and isolating flange for leaks. For a period of 1 minute after shut down the engine must not drip oil out of the venting tube. In case of uncertainty determine the oil amount. An oil leak is when after 20 min engine run more than 0.5 ml of oil loss is detected.

**Coolant hoses**

Check coolant hoses and connections and fittings for leakage. Examine the surrounding area to see if there are any leaks!

**Oil lines**

Inspect all oil feed lines from the oil tank to the oil cooler and to the engine. Also inspect the oil return line from the crankcase to the oil tank. Check the pressure oil line from the oil pump to the governor flange of the governor.

**Hose clamps, kinks**

Check all hoses, particularly in the area of the hose clamps and hose connections, for porosity, damage and kinks. If damage is detected, replace hose immediately.

**BRP-Powertrain**  
MAINTENANCE MANUAL

## 5) Checking the compression

**General note** See Fig. 5.



Risk of electric shock!  
Ignition "OFF" and system grounded!

**Special tools**

To measure the compression pressure the following special tools and equipment are necessary.

Part number	Description
n.a.	Compressed air approx. 6 bar (87 psi).
n.a.	2 pressure gauges.
n.a.	Orifice jet*, of 1mm (0.04 in) inner diameter and 3 mm (0.12 in) length. * or equivalent e.g. orifice diameter 0.040 in., long 0.0250 in., 60° degree approach angle according to AC43.13, latest issue.
n.a.	Adapter to spark plug thread.
n.a.	Connecting hoses.

**Instruction**

Testing is carried out using the **differential pressure test procedure**.

Step	Procedure
1	Operate the engine until the temperatures have stabilized for a period of 5 min (engine oil temperature between 50 to 70 °C (122 - 160 °F).
2	Started with cylinder head 1 move piston to TDC position.
3	Remove the upper spark plugs. Prevent dirt or other foreigner particles from penetrating the engine (A).
4	Screw adaptor (1) into the spark plug thread and connect up the two pressure gauges (2) with the orifice jet (3) between them (B).
5	Now put constant pressure, between 5,5-6 bar (80-87 psi) on the line and take readings at pressure gauge (C).
6	Repeat this proceeding at all 4 cylinder heads.

**Value**

The maximum permissible pressure drop is 25 %, e.g. from 6 to 4.5 bar (87 psi to 65 psi) (D).

If the pressure loss is less than 25% then the valve seats and piston rings are working properly. The spark plug has to be installed according to chap. 12-20-00 section: 13.2).

If the value is over 25% inspection, repair or overhaul must be carried out in accordance with the BRP-Powertrain instructions for continued airworthiness.

- Detailed inspection of affected engine components.

d055661.fm

**BRP-Powertrain**  
**MAINTENANCE MANUAL**

**Graphic**

**Checking the compression.**

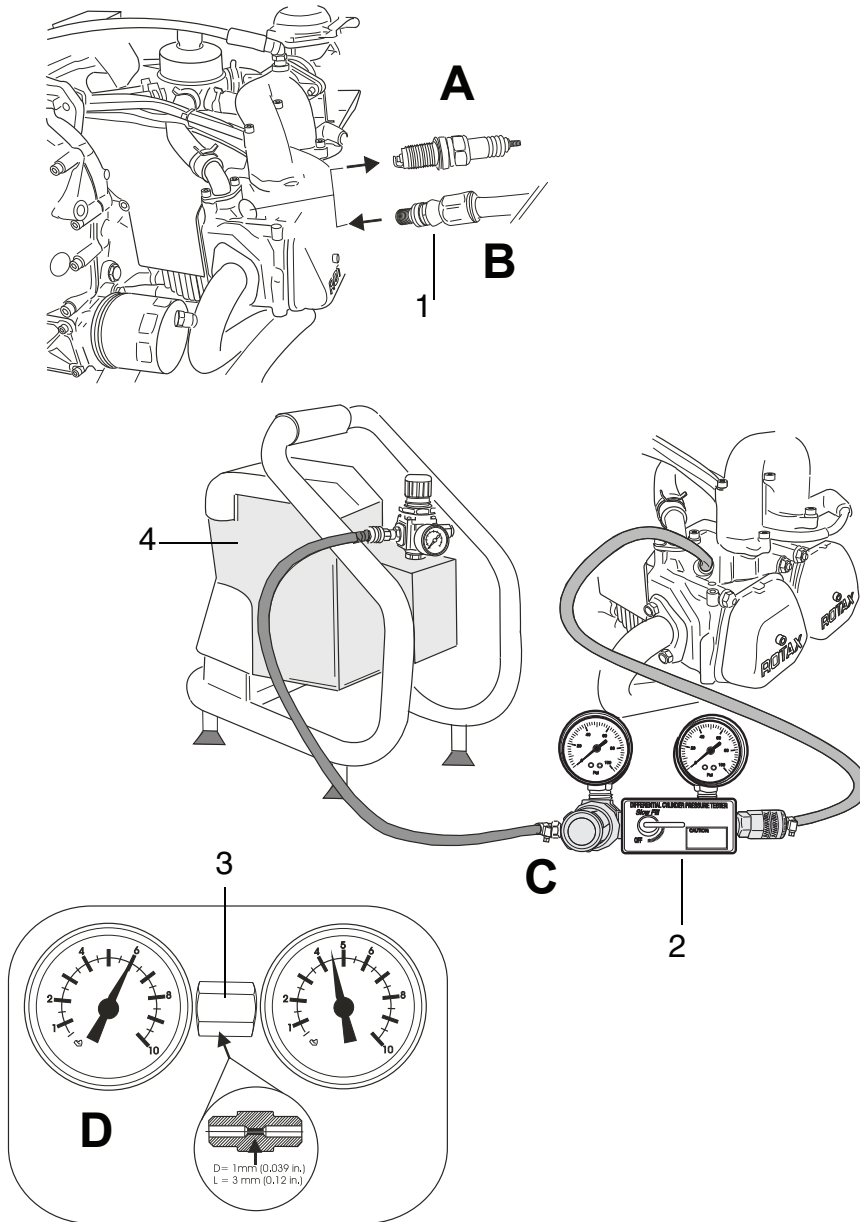

Part	Function
1	Adaptor
2	Manometer/Test gauges set
3	Orifice jet
4	Compressor

*Fig. 5*

08529

c05561.fm

### 5.1) Compression check for fault-tracing

**General note** In the course of fault-tracing a **compression check** can also be performed.

A compression tester is required to check compression. The compression should be between 9 and 12 bar (130 and 174 psi).

**Instruction** Compression check for fault-tracing.

Step	Procedure
1	Operate the engine until the temperatures have stabilized for a period of 5 min (engine oil temperature between 50 to 70 °C (122 - 160 °F).
2	Unscrew and remove top spark plugs.
3	Press compression tester (1) over the spark plug hole and use the starter to turn the engine over with open throttle until maximum pressure is reached.
4	Successively take readings on all four cylinders and compare results.

**Measurement** Individual readings for the cylinder must not differ by more than 2 bar (29 psi).

If the value is below 6 bar (87 psi), inspection, repair or overhaul must be carried out in accordance with the BRP-Powertrain instructions for continued airworthiness.

- Detailed inspection of affected engine components.

**Graphic** Compression check for fault-tracing

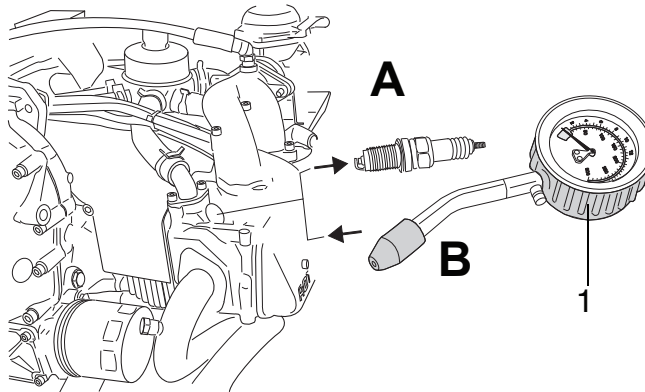

Part	Function
1	Compression tester

Fig. 6

08651

d055661.fm

**BRP-Powertrain**  
MAINTENANCE MANUAL

NOTES

## 6) Checking the V-belt tension

**General note** See also [Fig. 8](#).  
In the case of configurations with additional auxiliary generator, inspect attachment and V-belt tension.

---

**Checking the V-belt tension** Inspect V-belt tension as per drawing below.

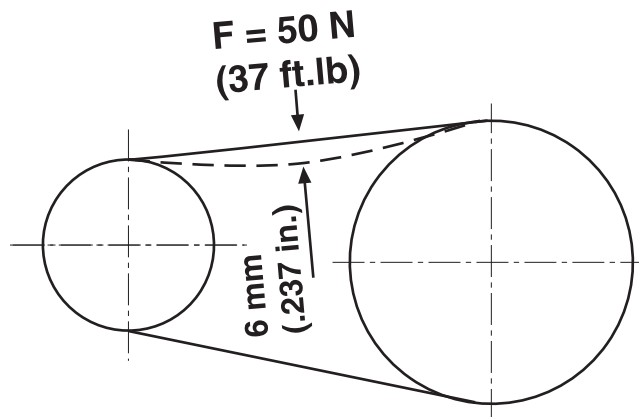

Fig. 7

08663

**BRP-Powertrain**  
**MAINTENANCE MANUAL**

**6.1) Adjust the V-belt tension**

**Belt tension** To adjust the belt tension:

Step	Procedure
1	Loosen the hex. screw (1) M10 and the two M8 allen screw (2) and (3).
2	Press the alternator upwards and tighten allen screw (3).
3	Then tighten hex. screw (1) M10 with tightening torque 40 Nm (30 ft.lb) and allen screw M8 (2) with tightening torque 22 Nm (195 in.lb).

**Graphic** Checking the V-belt tension

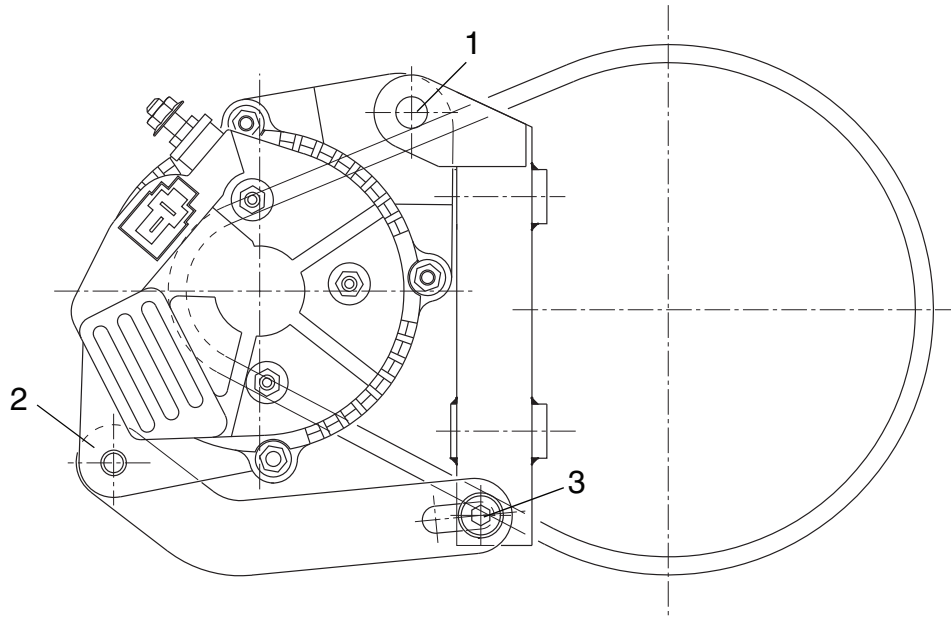

Part	Function
1	Hex. screw M10
2, 3	Allen screw M8

*Fig. 8*

00353

**BRP-Powertrain**  
MAINTENANCE MANUAL

**7) Locking the crankshaft**

**General note** See Fig. 9 and Fig. 10.

**NOTES:** The thread bolt for crankshaft locking is part of the standard tool kit supplied with each engine.

**Locking the crankshaft**



Risk of severe burns and scalds!  
Hot engine parts!  
Always allow engine to cool down to ambient temperature before start any work.

**Special tools**

For accomplishment the following special tool is required.

Part number	Description
part no. 240880	(1) Thread bolt

**Graphic**

Special tool

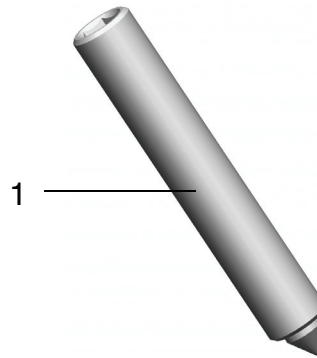

Part	Function
1	Thread bolt

*Fig. 9*

05910

The following work procedures are to be accomplished:

Step	Procedure
1	Remove the plug screw (1) M8x20 and sealing ring from the crankcase half (cyl. 2/4).
2	Turn crankshaft/propeller shaft until the piston of cyl. no. 1 and no. 2 are in TDC position and lock crankshaft in this position with the thread bolt (2) part no. 240880.  <b>NOTES:</b> Turn crankshaft for relief the position indication until the trigger boss (3) is between the both trigger coil (4, 5) at the position.  The required recess position of the crankshaft can be additionally verified by looking through the crankcase recess (6) with a flash light.

d05561.fm

**BRP-Powertrain**  
**MAINTENANCE MANUAL**

Step	Procedure
3	Screw the thread bolt (2) into the crankcase. While doing so, move the crankshaft to and fro slightly with the ring spanner until the locking screw engages in the recess (6) of the crankshaft, and tighten to 10 Nm (88.48 in.lb).

**Loosen the crankshaft**

After completion of work/check:

Step	Procedure
1	Remove the thread bolt (2) and refit crankshaft plug screw M8x20 (1) along with a new sealing ring with a torque of 15 Nm (133 in.lb).

**Graphic**

**Locking the crankshaft**

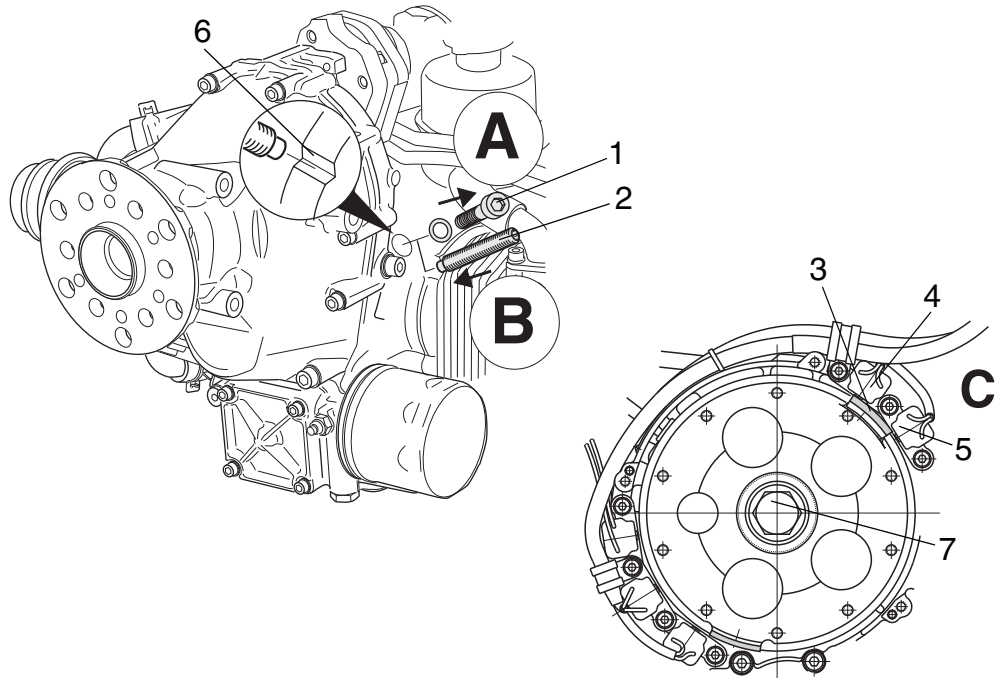

Part	Function
1	Plug screw M8x20
2	Thread bolt
3	Trigger boss
4,5	Trigger coils
6	Crankshaft
7	Hex. screw M16x1,5x40

*Fig. 10*

08530,08531

**BRP-Powertrain**  
MAINTENANCE MANUAL

## 8) Test run of engine

### General note



Danger of life threatening injuries caused by the propeller, rotating and stressed parts of the engine! Always observe the engine from a safe place while it is running. Check that the cockpit is occupied by a competent operator.

### Preparation

Preparation of the engine for test run:

- Ensure that all the operating fluids (engine oil, coolant, fuel) are replenished to the specified level.
- Make sure that no loose objects (e.g. tools) are left in the engine compartment.
- Inspect tight fit of the propeller.
- Anchor the aircraft suitably to the ground and fix wheel chocks. Ensure that the propeller zone is clear and safe before starting the engine.

### Test run

Test run as follows:

Step	Procedure
1	Establish fuel supply (open fuel cock).
2	Activate choke.
3	Throttle lever to idle position.
4	Master switch "ON".
5	Ignition for both ignition circuits "ON".
6	Press starter switch for max. 10 sec. (followed by a cooling period of 2 min.).
7	After engine start, observe oil pressure. Oil pressure has to be built up within 10 sec.
8	Let engine run for approx. 2 min. at 2000 rpm. Then first use the throttle lever to bring the engine to approx. 2500 rpm and then run through warming up period, until the oil temperature reaches 50 °C (122 °F).
9	Check temperatures and oil pressure: At a steady oil temperature above 50 °C (122 °F) and oil pressure above 2 bar (29 psi) engine speed may be increased.
10	Ignition check as per the current Operators Manual.
11	Conduct a short full throttle run and check that the engine reaches the max. full power speed. Consult the pilot's operating handbook for maximum speed, as it depends on the propeller used.
12	After full-load run, conduct a short cooling run to prevent formation of vapour lock in cylinder heads. This is necessary to prevent steam locks in the cooling and fuel system after shut-down.

d055661.fm

**BRP-Powertrain**  
**MAINTENANCE MANUAL**

Step	Procedure
13	Shut engine down. NOTE: On switching off the engine switch off ignition and withdraw the ignition key.
14	Inspect rotary seal for leakage. NOTE: Due to the design of the rotary seal, the manufacturer tolerates a certain amount of leakage. If the leakage is in excess of the limit rotary seal must be renewed. Tolerated leakage: For this check the engine must be operated until all temperatures have stabilized for a period of 5 minutes. At that point shut down engine and ensure the ignition is switched off and engine secured against unintentional operation. Coolant must not drip through leakage bore, located at the base of the ignition housing, for a period of 1 minute after the engine has been stopped. In case this leakage test can not be passed, the rotary seal must be renewed.

**Engine oil and coolant**



Risk of severe burns and scalds!  
 Never open the radiator cap when the cooling system is hot. For safety's sake, cover cap with a rag and open slowly. Sudden opening of the cap could provoke the escape of boiling coolant and result in scalding.

Replenish engine oil and coolant as required once engine has cooled down.

**Oil filter**



If the oil filter has been replaced, re-tighten by hand after the trial run on a cold engine.

**Check of leaks**

Inspect the engine for oil, fuel or coolant leaks and repair as necessary.

## 9) Cooling system

### 9.1) Checking the cooling system

#### Overview

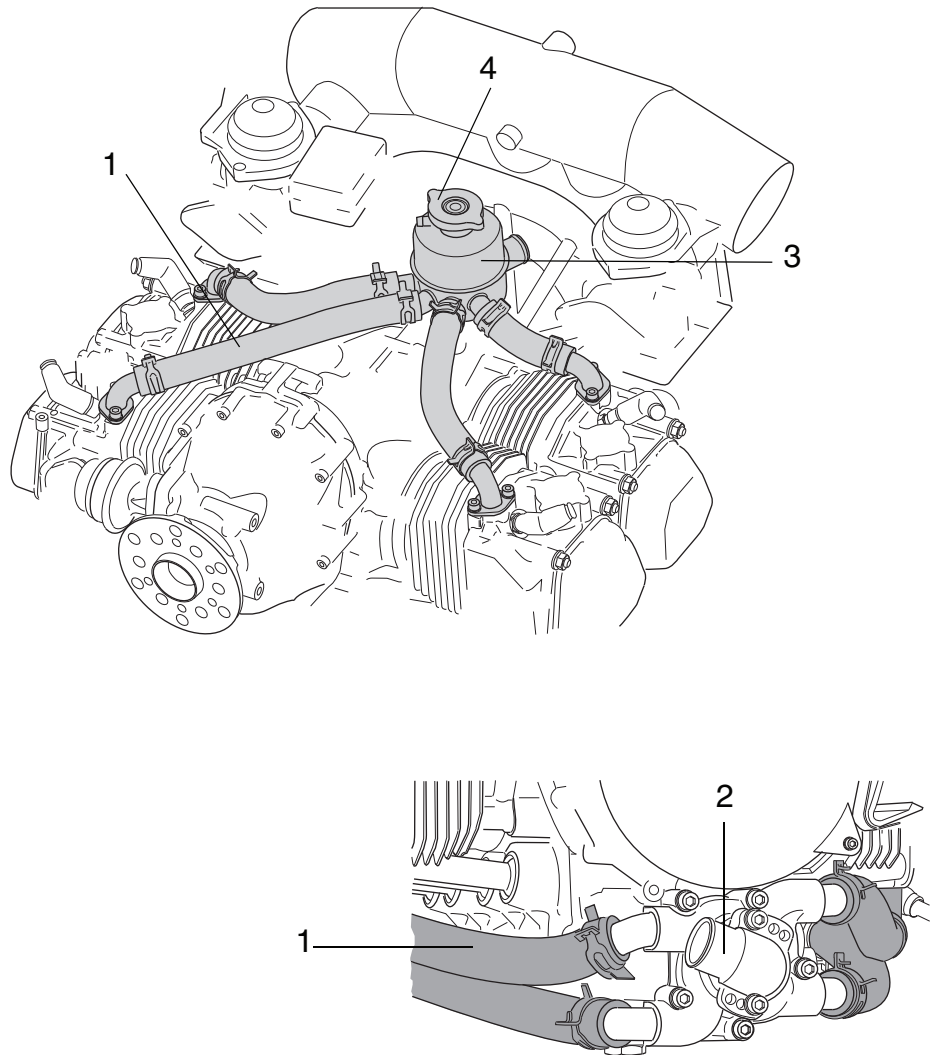

Part	Function
1	Coolant lines
2	Water pump
3	Expansion tank
4	Radiator cap with gasket

Fig. 11

08532

d055661.fm

**BRP-Powertrain**  
MAINTENANCE MANUAL

**General note**



Risk of severe burns and scalds!  
Hot engine parts!  
Always allow engine to cool down to ambient temperature before start of any work.

See Fig. 11.

---

**Coolant hoses**

Carry out visual inspection of all coolant hoses (1) for damage, leaks, hardening as a result of heat and porosity.

---

**Water pump**

Inspect all connections on the top and bottom of the cylinder head and on the water pump (2).

---

**Expansion tank**

Inspect expansion tank (3) for damage. Inspect protection rubber at the bottom of the tank for tight fit.

---

**Radiator cap**

Inspect the gasket of the radiator cap (4) and check the pressure release valve and return valve for proper operation.

See chap. 12-20-00 section: 9.4).

---

## 9.2) Replacing the coolant

**General note**

See Fig. 12.



Risk of severe burns and scalds!  
Never open the radiator cap when the cooling system is hot. For safety's sake, cover cap with a rag and open slowly. Sudden opening of the cap could provoke the escape of boiling coolant and result in scalding.

**NOTICE**

Use only coolant as recommended in the current Operators Manual and also see SI-912-016.

**ENVIRONMENT NOTE**

Coolant and mixtures of coolant and water have to be treated as hazardous waste!

**Instruction**

To replace the coolant the following steps are necessary:

Step	Procedure
1	Open the radiator cap on the expansion tank.
2	Remove the bottom attachment screw (1) (with sealing ring) of water pump (2).

**BRP-Powertrain**  
**MAINTENANCE MANUAL**

Step	Procedure
3	Drain the engine coolant. NOTES: If the radiator is located below the engine, also detach the lowest positioned coolant hose.
4	Fit attachment screw (stainless steel) along with a new sealing ring. Tighten to 10 Nm (90 in.lb).
5	If the coolant is being replaced with a different type, (conventional coolant, waterless coolant) the cooling system must be flushed. See chap. 12-20-00 section: 9.3).
6	Refill newly mixed coolant into the expansion tank (highest point of the cooling system). See chap. 12-10-00 section: 3.1).
7	Fit radiator cap.
8	NOTES: Run the engine briefly and replenish with clean coolant as required.

**Graphic**

**Replacing the coolant**

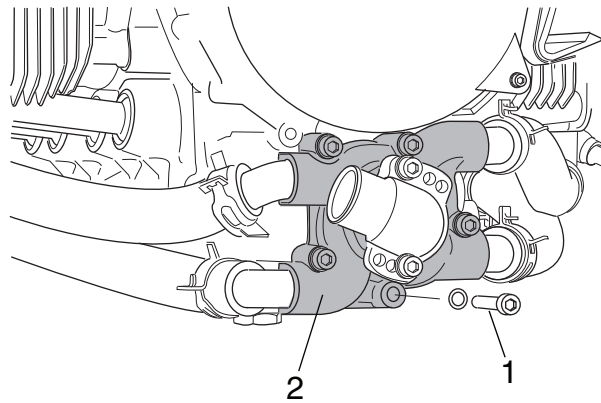

Part	Function
1	Attachment screw (stainless steel)
2	Water pump

*Fig. 12*

08533

d055661.fm

**BRP-Powertrain**  
MAINTENANCE MANUAL

### 9.3) Flushing the cooling system

General note



Hot steam can cause scalds in the face and on hands! Never open the radiator cap when the cooling system is hot. For safety's sake, cover cap with a rag and open slowly.

Instruction

To flush the coolant the following steps are necessary:

Step	Procedure
1	<p>The system is flushed using pure water at a pressure of 2 bar (29 psi).</p> <p><b>NOTICE</b> Where water-free coolant is used, the cooling system must be drained of water correspondingly after flushing. The residual water must not exceed the max. permissible limit prescribed by the coolant manufacturer.</p> <p>NOTES: For the flushing, open the lowest located coolant hose (either at water pump or radiator).</p>
2	Refill newly mixed coolant into the expansion tank (highest point of the cooling system). See chap. 12-10-00 section: 3.1).
3	Fit radiator cap.
4	NOTES: Run the engine for a minute and replenish coolant as required.

### 9.4) Expansion tank, radiator cap

**General note**

See Fig. 13.

To equalize pressure in the cooling system, an expansion tank is required. If the pressure in the system rises above 1.2 bar (17.4 psi) as the coolant warms up, the pressure relief valve (1) opens and the coolant can flow into the expansion tank via the line (5). When the coolant cools down, the return valve (2) opens and the coolant is sucked back.

**NOTES:** On older engines a radiator cap with opening pressure of 0.9 bar (13.0 psi) can be installed. See SI-912-020 "Running Modification", latest issue.

**Radiator cap**

Inspect the rubber seal (3), the pressure spring (4) and the two valves incorporated in the radiator cap for damage and leaks. If necessary, replace with a new original radiator cap with 1.2 bar (17.4 psi) (6) opening pressure.

**NOTES:** The radiator cap must be tightened fully on the expansion tank.

**Expansion tank**

Inspect sealing surface (7) and tube connection (8) of the expansion tank. Carry out visual inspection of tank for damage and scuffing marks.

**Graphic**

Checking Expansion tank, radiator cap.

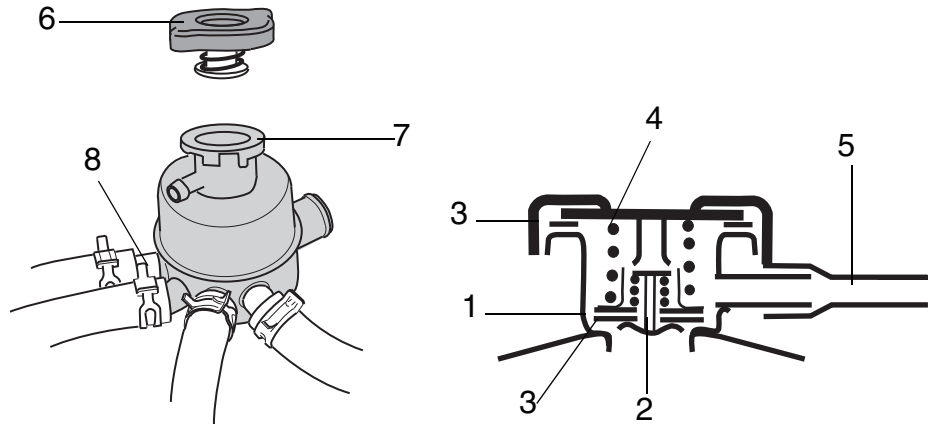

Part	Function
1	Pressure relief valve
2	Return valve
3	Rubber seal

d055661.fm

**BRP-Powertrain**  
MAINTENANCE MANUAL

Part	Function
4	Pressure spring
5	Connection to overflow bottle
6	Opening pressure of the radiator cap
7	Sealing surface
8	Tube connections

*Fig. 13*

08534,07620

**BRP-Powertrain**  
**MAINTENANCE MANUAL**

**9.5) Overflow bottle**

**General note** See Fig. 14.

**Instruction** Checking overflow bottle.

Step	Procedure
1	Inspect the bottle for damage.
2	Check the venting bore (1) in the screw cap (see Service Bulletin SB-912-039, "Modification of the overflow bottle", latest issue).
3	Inspect bracket (2) for the safety wire.
4	Check hose connection (3).

**Graphic** Overflow bottle

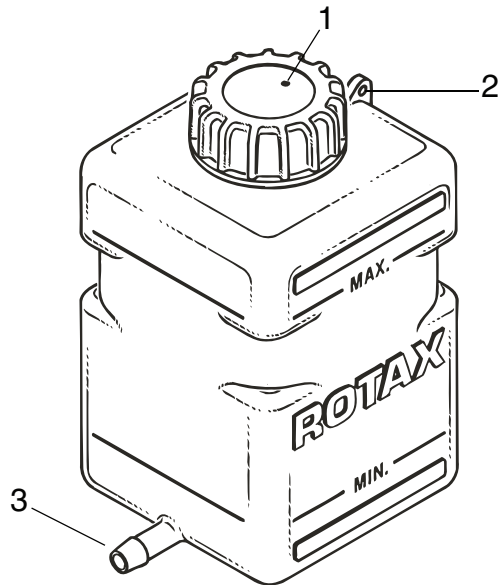

Part	Function
1	Venting bore
2	Bracket
3	Hose connection

Fig. 14

08536

**9.6) Accessories (including radiator, radiator hoses, hose clamps, cooling air ducts)**

**General note** **NOTICE** Equipment is to be inspected in accordance with the Maintenance Manual of the aircraft manufacturer.

d055661.fm

**BRP-Powertrain**  
MAINTENANCE MANUAL

NOTES

## 10) Fuel system

### 10.1) Carburetor synchronization

**Idle speed      Checking the synchronization at idle speed**

See Fig. 15.

For smooth idling, synchronization of the throttle valves is necessary. When synchronizing, slacken both bowden cables (throttle lever lies close on the adjustment screw).

**Instruction**      To synchronize when idling the following steps are necessary.

Step	Procedure
1	Detach the resonator hose (1) of the compensating tube (2) to separate the two air intake systems. In this condition, a slight difference in the engine running should be noticeable.

**NOTES:**      First carry out the mechanical synchronization and then the pneumatic synchronization (if required).

**Graphic**      Synchronization at idle speed

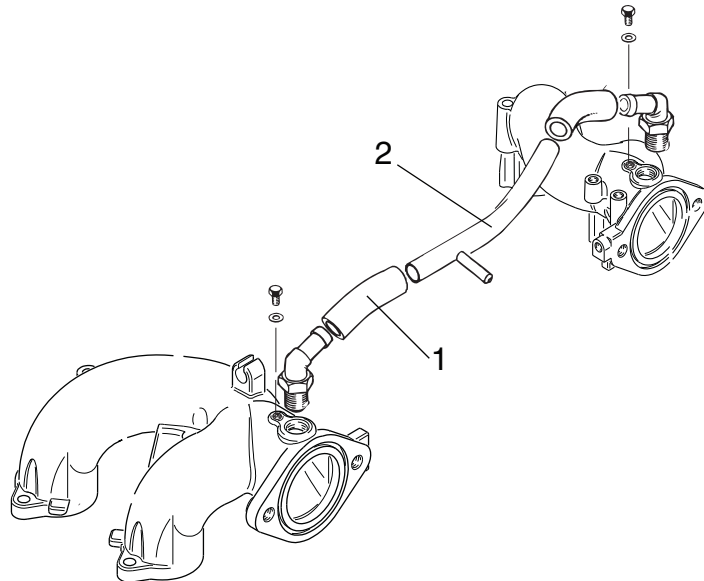

Part	Function
1	Resonator hose
2	Compensating tube

*Fig. 15*

05491

d055661.fm

## 10.2) Mechanical synchronization

**General note** See Fig. 16.



Danger of life threatening injuries caused by the propeller, rotating and stressed parts of the engine!  
Always observe the engine from a safe place while it is running.

### Basic throttle adjustment

For synchronous basic throttle adjustment proceed as follows.

Step	Procedure
1	Remove cable fixation (4) on throttle lever (1).
2	Return the throttle lever (1) to its idle stop position (3) by hand. There should be no resistance during this procedure.
3	Unscrew idle speed adjustment screw (2) until it is free of the stop.
4	Insert a 0.1 mm (0.004 in.) feeler gauge (gap X) between the idle speed adjustment screw (2) and the carburetor idle stop (3), then gently turn the idle screw clockwise until contact is made with the 0.1 mm (0.004 in.) feeler gauge.
5	Pull out the feeler gauge and then turn each idle speed adjustment screw (2) 1.5 turns clockwise.
6	Gently turn each idle mixture screw (6) (clockwise) until it is fully inserted and then reopen by 1.5 turns counter clockwise.
7	Check that the throttle valve opens fully automatically.
8	Adjust the two bowden cables for simultaneous opening of the throttle valves.

Carry out the above procedure on both carburetors.

### Synchronization

You must at this point place the throttle lever in the cockpit to the idle stop position. It is an advantage at this point to enlist the help of an assistant to ensure that the throttle lever remains in this position during the next steps of the synchronization process.

Step	Procedure
1	As soon as the throttle lever in the cockpit remains in the idle stop position, check the throttle valve lever (1) to the carburetor idle stop position (3).
2	Using the cable fixation (4), secure the bowden cable accordingly.
3	As soon as the two carburetor bowden cables are installed (throttle lever in cockpit in idle position), you must check that the idle speed adjustment screw (2) rests fully on the idle stop (3) without pressure.

**BRP-Powertrain**  
**MAINTENANCE MANUAL**

Step	Procedure
4	<p><b>NOTICE</b> An idle speed which is too low can result in gearbox wear, and if the idle speed is too high, the engine is harder to start.</p> <p>Start the engine and verify the idle speed. If the idle speed is too high or too low, adjust accordingly with idle speed adjustment screw (2).</p>
5	<p>Check the true running of the engine. If necessary, adjust with the idle mixture screw (6).</p> <p>See chap. 12-20-00 section: <a href="#">10.5</a>.</p>

Carry out the above procedure on both carburetors.

**Graphic**

**Mechanical synchronization**

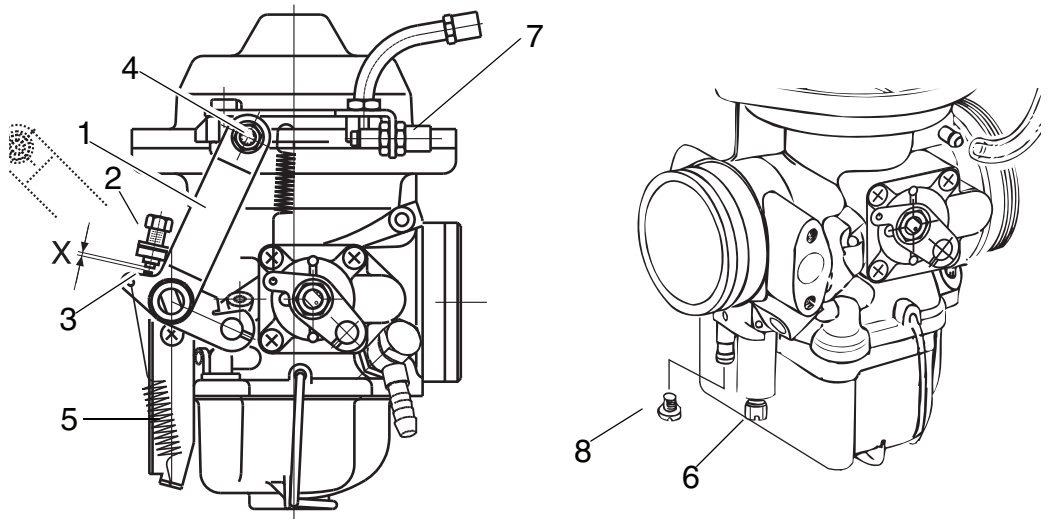

Part	Function
1	Throttle valve lever
2	Adjustment screw
3	Idle stop position
4	Cable fixation
5	Return spring
6	Idle mixture screw
7	Idle adjustment
8	Plug screw M3.5x5

*Fig. 16*

08538

d05561.fm

**BRP-Powertrain**  
MAINTENANCE MANUAL

**10.3) Pneumatic synchronization**

General note See Fig. 17 to Fig. 19.



**WARNING** Danger of life threatening injuries caused by the propeller, rotating and stressed parts of the engine!  
Always observe the engine from a safe place while it is running.

NOTES: Perform a mechanical synchronization before attempting a pneumatic synchronization.

Special tool The two carburetors are adjusted to equal flow rate at idling with a suitable flow meter or vacuum gauge(s).

Connection Possible connection methods.

Option 1	
Step	Procedure
1	Remove the compensating tube (2) from the push on angular tube (4) after removing the two clamp (3).
2	Using the push on angular tube (4) and compensating tube (2) install a flexible rubber hose (5) leading to the vacuum gauge (1).

Graphic Option 1

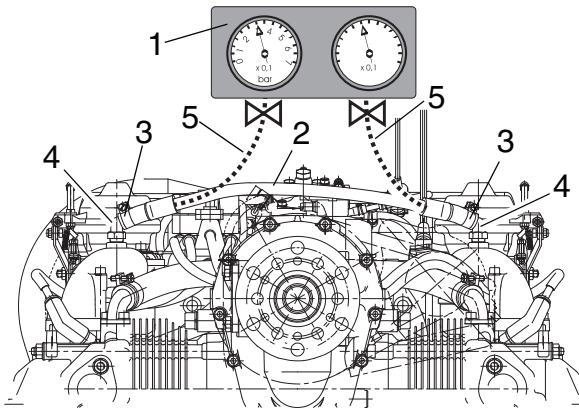

Part	Function
1	Vacuum gauge
2	Compensations tube
3	Clamp
4	Angular tube
5	Rubber hose

Fig. 17

08652

c005561.fm

**BRP-Powertrain**  
**MAINTENANCE MANUAL**

Option 2	
Step	Procedure
1	Remove one end of the compensating tube (2) and tube (3) from the push on angular tube (5) after removing the two tension clamp (4).
2	Using the push on angular tube (5) and compensating tube (2) install a flexible rubber hose (6) leading to the vacuum gauge (1).

Graphic

Option 2

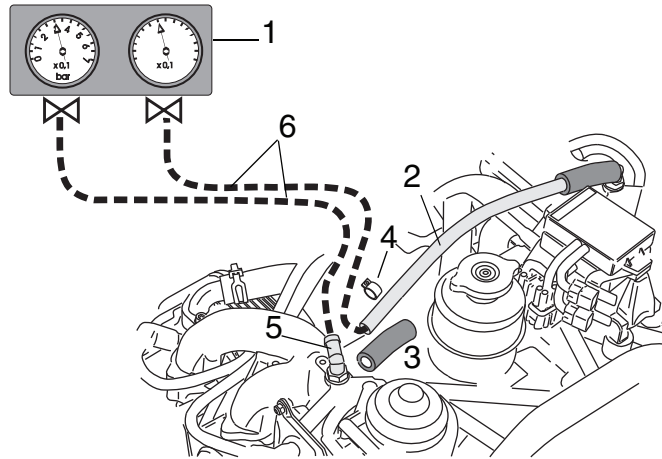

Part	Function
1	Vacuum gauge
2	Compensating tube
3	Tube
4	Clamp
5	Angular tube
6	Rubber hose

Fig. 18

08659

d055661.fm

**BRP-Powertrain**  
**MAINTENANCE MANUAL**

Option 3	
Step	Procedure
1	Remove hex. screw (1) M6x6 from intake manifold (2) and connect the vacuum gauge.
2	Remove the compensation hose (3) with attached resonator hose (4) (connection between intake manifolds) and plug the fittings in the intake manifolds.
3	After synchronization tightened the screw M6x6 (1) with LOCTITE 221.

Graphic

Option 3

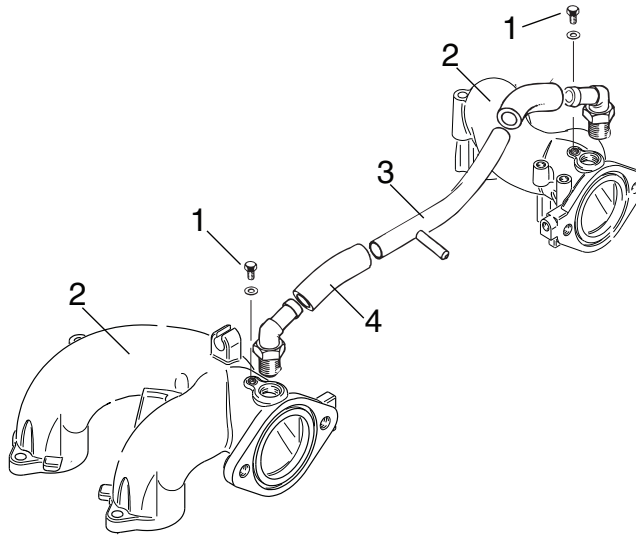

Part	Function
1	Hex. screw M6x6
2	Intake manifold
3	Compensation tube
4	Resonator hose

Fig. 19

08660

**BRP-Powertrain**  
**MAINTENANCE MANUAL**

Option 4	
Step	Procedure
1	Install the vacuum gauge.
2	Clamp the tube (2) with hose clamping pliers (1). Observe the position! Do not remove the compensation tube (3).
3	Unscrew the screw (4).
4	Install a hose nipple M6 (5) with sealing ring or O-ring (6).
5	After synchronization remove the hose nipple M6 (5).
6	Secure screw M6x6 (4) with a new gasket (6) and LOCTITE 221.

Graphic

Option 4

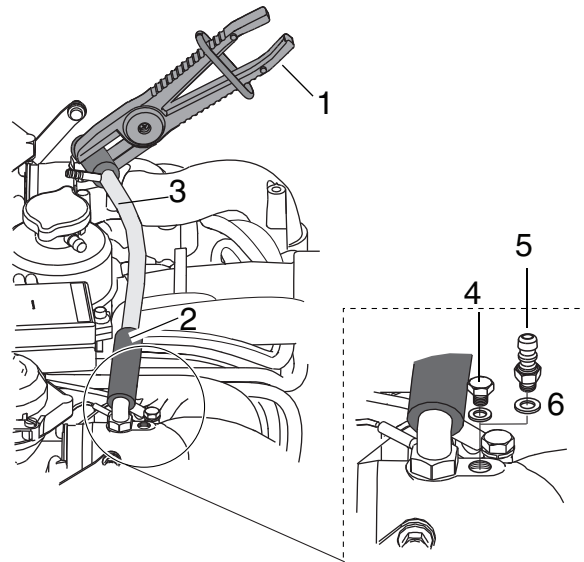

Part	Function
1	Clamping pliers
2	Tube
3	Compensation tube
4	Screw
5	Hose nipple
6	Sealing ring

Fig. 20

08661

d055661.fm

**BRP-Powertrain**  
MAINTENANCE MANUAL

### 10.3.1) Idle speed check

**General note** Before proceeding, secure the aircraft on the ground using wheel chocks and ropes.



Risk of life threatening injuries caused by propeller!  
Secure the propeller region before test run watch it.  
Secure a safe area around propeller during test run.

Start the engine and verify the idle speed. If necessary correct as per chap. 12-20-00 section: [10.5](#)).

Setting of more than 1/2 turn
If a setting of more than 1/2 turn is required, repeat mechanical synchronization to prevent too high a load on the idle stops. If the idle speed is too high, the maximum the idle screw can be unscrewed is complete turn.

**No satisfactory result**

If an unsatisfactory result is achieved, inspect the idle jets for contamination and clean if necessary.

**NOTICE**

Also check for translucent, jelly-like contamination. Inspect for free passage.

**BRP-Powertrain**  
 MAINTENANCE MANUAL

**10.3.2) Operating range check**

**General note**      Once the proper idling speed has been established, it is necessary to check the **operating range above the idle speed**.  
 First establish that the engine is developing full take-off performance or take-off rpm when selected in the cockpit. Then the setting of the operating range (idle to full throttle) can be checked or adjusted.

**Procedure**              To control the operating range above idling the following steps are necessary. See Fig. 21.

Step	Procedure										
1	Start and warm up engine (See Operators Manual). Select full power and check that both pressure gauges are registering the same readings. If the same reading is not made on both gauges. <table border="1" style="margin-left: 20px;"> <thead> <tr> <th style="text-align: center;">Step</th> <th style="text-align: center;">Procedure</th> </tr> </thead> <tbody> <tr> <td style="text-align: center;">1</td> <td>Shut down the engine.</td> </tr> <tr> <td style="text-align: center;">2</td> <td>Check that carburetor actuation effects full travel and that starting carburetors (choke) are in the full off position.</td> </tr> <tr> <td style="text-align: center;">3</td> <td>If necessary, fit/modify the carburetor actuation as required to achieve full power on both carburetors.</td> </tr> </tbody> </table>	Step	Procedure	1	Shut down the engine.	2	Check that carburetor actuation effects full travel and that starting carburetors (choke) are in the full off position.	3	If necessary, fit/modify the carburetor actuation as required to achieve full power on both carburetors.		
Step	Procedure										
1	Shut down the engine.										
2	Check that carburetor actuation effects full travel and that starting carburetors (choke) are in the full off position.										
3	If necessary, fit/modify the carburetor actuation as required to achieve full power on both carburetors.										
2	Once full power has been established on both carburetors, retard the throttle and observe the pressure gauge settings. The pressure gauges should show the same reading for both carburetors. NOTES:              Discrepancies must be compensated for by adjusting the off idle adjustment (1). <table border="1" style="margin-left: 20px;"> <thead> <tr> <th style="text-align: center;">Step</th> <th style="text-align: center;">Procedure</th> </tr> </thead> <tbody> <tr> <td style="text-align: center;">1</td> <td>Shut down the engine.</td> </tr> <tr> <td style="text-align: center;">2</td> <td>Loosening the locknut on the bowden cable and adjusting the off idle adjustment.</td> </tr> <tr> <td style="text-align: center;">3</td> <td>Tightening the locknut.</td> </tr> <tr> <td style="text-align: center;">4</td> <td>Re-testing the engine.</td> </tr> </tbody> </table>	Step	Procedure	1	Shut down the engine.	2	Loosening the locknut on the bowden cable and adjusting the off idle adjustment.	3	Tightening the locknut.	4	Re-testing the engine.
Step	Procedure										
1	Shut down the engine.										
2	Loosening the locknut on the bowden cable and adjusting the off idle adjustment.										
3	Tightening the locknut.										
4	Re-testing the engine.										
3	Final idle speed adjustment may be required by resetting the idle speed adjustment screws (2).										
4	Equal adjustment must be made on both carburetors.										
5	Any major adjustments required necessitate replaced verification of all parameters mentioned in this procedure.										

d05561.fm

**BRP-Powertrain**  
MAINTENANCE MANUAL

**Assembly**

**NOTICE**

Follow the instructions of the instrument manufacturer.

- Install compensation tube assy. on engine in reverse sequence of removal. Any minor differences in balance at idle speed will be compensated for.
- Refit the screw plug M3.5 (3) and hex. screws M6x6 with gasket (pos. 1 Fig. 19).

**Graphic**

Inspect operating range/idle speed

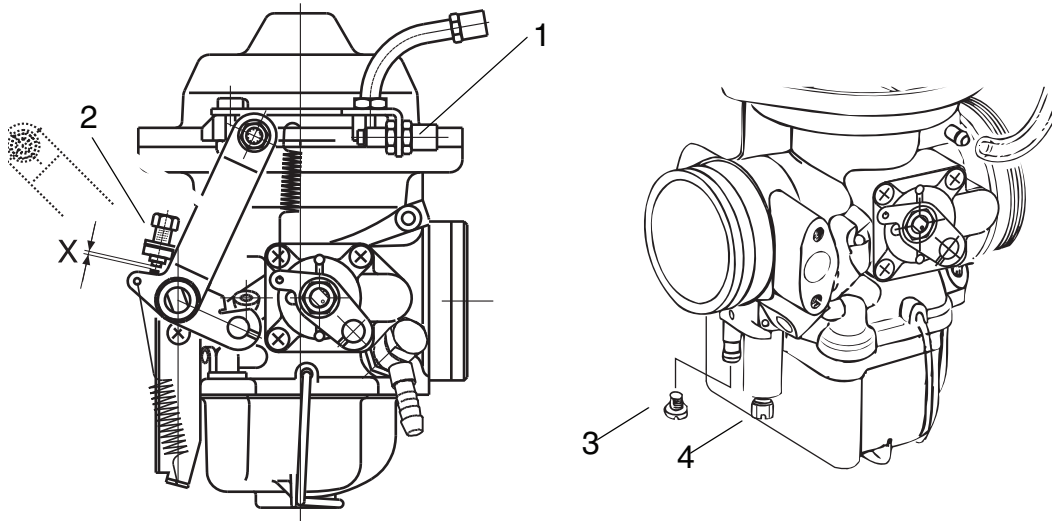

Part	Function
1	Idle adjustment
2	Idle speed adjustment screw
3	Screw plug M3.5x5
4	Idle mixture screw

Fig. 21

08538

## 10.4) Checking of the float chamber

**General note** See Fig. 22.



**WARNING**

Risk of severe burns or scalds!

Hot engine parts!

Always allow engine to cool down to ambient temperature before start of any work.

**Instruction**

To check of the float chamber the following steps are necessary:

Step	Procedure
1	Remove drip tray (1).
2	Open spring clip (2).
3	Remove float chamber (3) with gasket (4) and both float.
4	Remove both float (5) from the float chamber.
5	Inspect the float chamber for contamination and corrosion.

**NOTICE**

If any contamination on float chamber the find out what the cause is and take corresponding action to rectify the problem. Inspect and clean the complete fuel system including carburetor.

Step	Procedure
6	Assembly at the float chamber should be carried out analogously the disassembly.
7	Adjust with the idle speed adjustment. See chap. 12-20-00 section: 10.5).

**BRP-Powertrain**  
**MAINTENANCE MANUAL**

Graphic

Float chamber

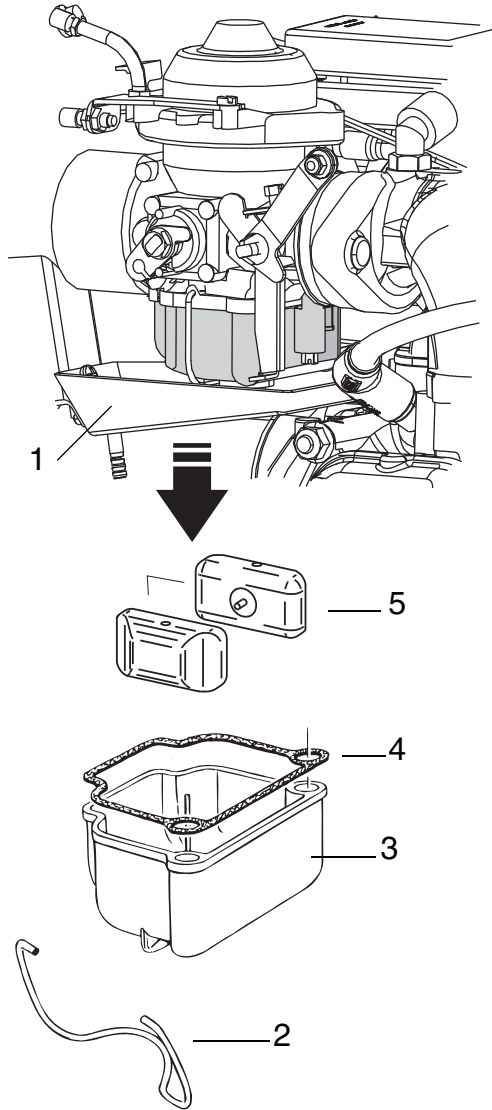

Part	Function
1	Drip tray
2	Spring clip
3	Float chamber
4	Gasket
5	Float

*Fig. 22*

08653

c05561.fm

## 10.5) Idle speed adjustment

**General note** See Fig. 21.

**NOTICE**

If satisfactory idle speed adjustment cannot be achieved, inspection of the idle jet or additional pneumatic synchronization will be necessary. See chap. 12-20-00 section: 10.3).

**Idle adjustment** Always carry out idle speed adjustment when the engine is warm.

- Basic adjustment of the idle speed is first effected using the idle speed adjustment screw (2) of the throttle valve. See chap. 12-20-00 section: 10.2).

**Optimizing engine running** Necessary only if not taken care of at synchronization.

Step	Procedure
1	Close idle mixture screw (4) by turning clockwise to screw in fully and then opening again by 1.5 turns counter clockwise.
2	Starting from this basic adjustment, the idle mixture screw (4) is turned until the highest idle speed is reached.
3	The optimum setting is the middle between the two positions at which an rpm. drop is noticed.
4	Then readjustment of the idle speed is carried out using the idle speed adjustment screw (2) and if necessary, by slightly turning the idle mixture screw again.  NOTES:                      Turning the idle mixture control screw in clockwise direction results in a leaner mixture and turning counter clockwise in a richer mixture.

## 10.6) Checking the carburetor actuation

**General note**

See Fig. 23.

Route bowden cables in such a way that carburetor actuation will not be influenced by any movement of engine or airframe, thus possibly falsifying idle speed setting and synchronization.

NOTES: Each carburetor is actuated by two bowden cables. At position (1) connection for throttle valve, and at position (2) connection for choke actuation.

**⚠ WARNING**

Risk of life threatening injuries caused by propeller!  
Adjust bowden cables so that the throttle valve and the choke actuation of the starting carburetor can be fully opened and closed. Bowden cables and lever must not jam!

**⚠ WARNING**

Risk of life threatening injuries caused by propeller!  
With carburetor actuation not connected, the throttle valve is fully open. The initial position of the CD carburetor is **full throttle!** So never start the engine with the actuation disconnected.

**Procedure**

To test the carburetor actuation the following steps are necessary:

Step	Procedure
1	Inspect bowden cables and levers for free movement.
2	Bowden cable must allow full travel of lever from stop to stop.
3	Adjust throttle cables to a clearance of 1mm (0.04 in).
4	Inspect and lubricate linkage on carburetor and carburetor joints with engine oil.
5	Inspect return springs (3) and inspect engagement holes for wear.

**BRP-Powertrain**  
MAINTENANCE MANUAL

**Graphic**                      Checking the carburetor actuation

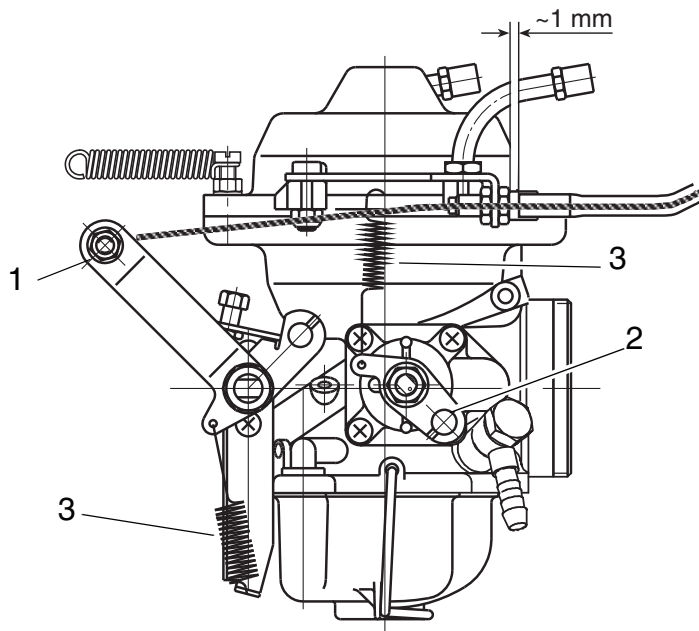

Part	Function
1	Connection for throttle valve
2	Connection for choke actuation
3	Return springs

*Fig. 23*

00352

d055661.fm

**BRP-Powertrain**  
MAINTENANCE MANUAL

NOTES

**11) Lubrication**

**11.1) General**

**Overview**

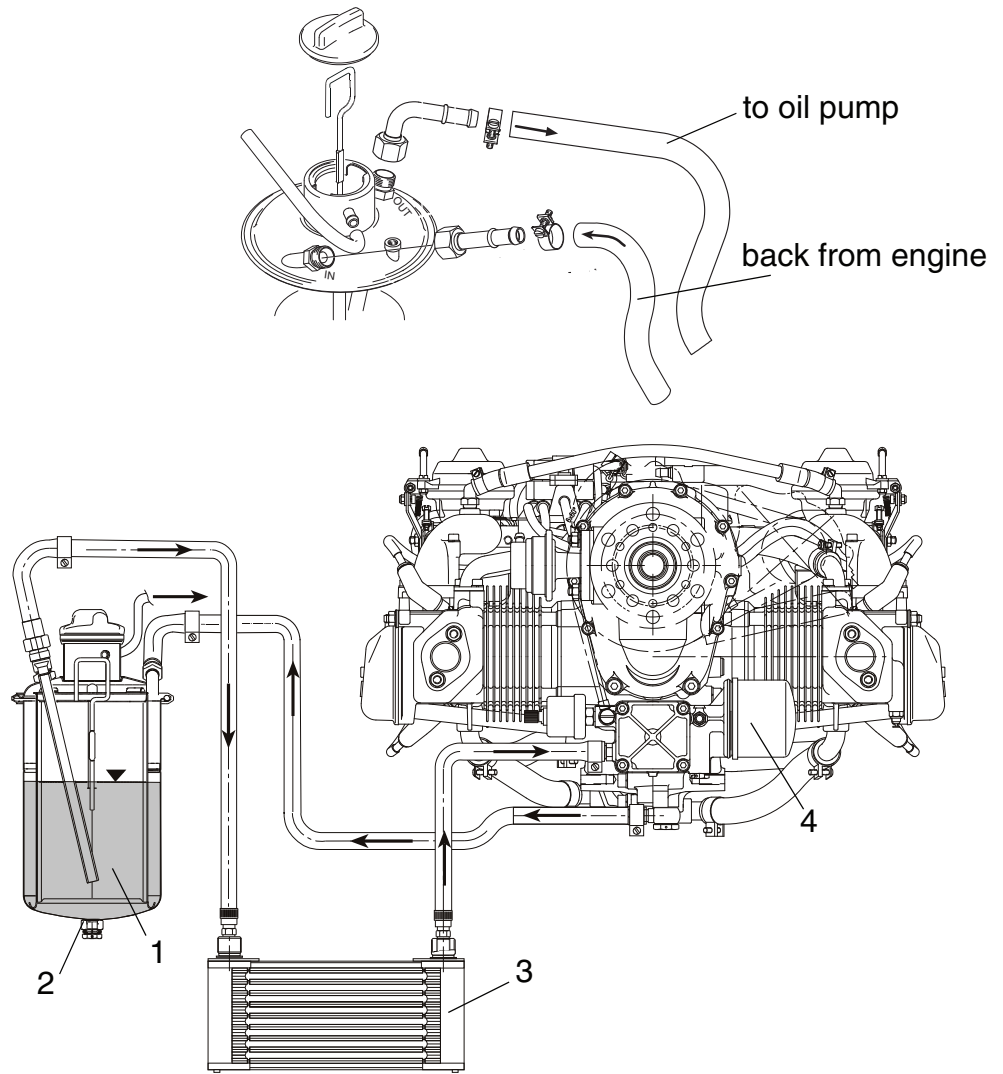

Part	Function
1	Oil tank
2	Drain screw M12x12
3	Oil cooler
4	Oil filter

*Fig. 24*

08238,08650

d05561.fm

# BRP-Powertrain

## MAINTENANCE MANUAL

### General note

For detailed information see SI-912-010 “oil change“, latest issue, and Fig. 24.

#### **WARNING**

Risk of severe burns and scalds!

Hot engine parts!

Always allow engine to cool down to ambient temperature before start of any work.

#### **WARNING**

Risk of electric shock!

Switch off ignition and remove key! Disconnect negative terminal of aircraft battery.

### NOTES:

It is advisable to check the oil level prior to an oil change as it informs about oil consumption.

See chap. 12-10-00 section: 4.1).

### Observe!

#### **NOTICE**

Observe the following to prevent possible unintentional voiding of the oil system and damage to the valve drive:

- Draining the suction lines, oil cooler and return line is not necessary and must be avoided, as it results in air entering the oil system. Therefore see and carry out SI-912-018. See also chap. 12-20-00 section 11.6)
- Replacement of the oil filter and the oil change should be effected quickly and without interruption to prevent a draining of the oil system and the hydraulic tappets.

### Oil lines, Oil connections

Oil lines and other oil connections are not normally removed.

**BRP-Powertrain**  
 MAINTENANCE MANUAL

**11.2) Oil change**

Procedure

NOTES: Run engine to warm oil before beginning oil change procedure.

To change the oil the following steps are necessary:

Step	Procedure
1	Crank engine by hand to transfer the oil from the crankcase. See chap. 12-10-00 section: 4.1).
2	Remove safety wire and oil drain screw from the oil tank, drain the used oil and dispose of as per environmental regulations.
3	Replace oil filter at each oil change and inspect the filter insert. See chap. 12-20-00 section: 11.4).
4	Dispose of oil filter according to environmental regulations.
5	Install oil drain screw with new gasket with tightening torque 25 Nm (18 ft.lb) and safety wire.

**NOTICE**

Only use brand name oil in accordance with the latest Operators Manual and SI-912-016, "Selection of suitable operating fluids" latest issue.

**NOTICE**

The engine must not be cranked when the oil system is open. When the crankshaft was turned, then the oil system must be purged.

**NOTICE**

Compressed air must not be used to blow through the oil system (or oil lines, oil pump housing, oil bores in the housing).

**ENVIRONMENT NOTE**

Be careful that no oil enters the sewerage system or the soil - Risk of contamination of drinking water!  
 Collect waste oil and take it to the recycling center.

Step	Procedure
6	Install new oil filter.
7	Pour in approx. 3l (0.8 gal (US)) of fresh oil.
8	After carrying out the oil change, the engine should be cranked by hand in the direction of engine rotation (approx. 20 turns) to completely refill the entire oil circuit.

d055661.fm

### 11.3) Oil filter replacement

General note



Risk of severe burns and scalds!  
 Hot engine parts!  
 Always allow engine to cool down to ambient temperature before start of any work.



To ensure correct functioning of the oil circuit and the forced flow lubrication, use GENUINE ROTAX-oil filter only. Only these filters will ensure correct pressure in the by-pass valve.

At every oil change, unscrew the oil filter and cut open using special tool taking care not to produce chips.

Special tool

To carry out the procedure the following steps are necessary:

part number	Description
part no. 877620*	(1) Oil filter wrench
part no. 877670*	(2) Cutting tool
* or equivalent	

Graphic

Special tool

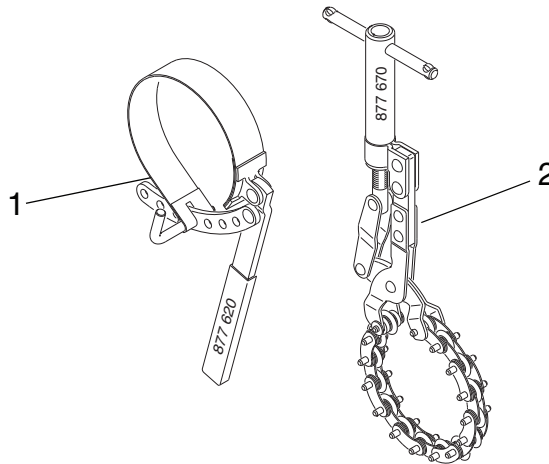

Fig. 25

02734

#### 11.3.1) Install/Remove of oil filter

General note

See Fig. 26.



After test run inspect tight fit of oil filter.

**BRP-Powertrain**  
MAINTENANCE MANUAL

**Procedure**

To install/remove the oil filter the following steps are necessary:

Step	Procedure
1	Remove used oil filter with oil filter wrench.
2	Clean the contact surface (1) of the oil pump housing (2) with a clean cloth.
3	Apply a thin film of engine oil on the gasket (3) of the new oil filter (4).
4	Install the new oil filter on the engine.
5	Screw on oil filter until oil filter gasket is seated solidly. NOTE: Sign 270 °C-mark on oil pump housing, so that the tightening of oil filter can be controlled.
6	Tighten oil filter with 3/4 turn (270°).
7	Inspection of used oil filter. See therefore chap. 12-20-00 section 11.4).

Inspect all systems for correct function.

**Graphic**

Install oil filter.

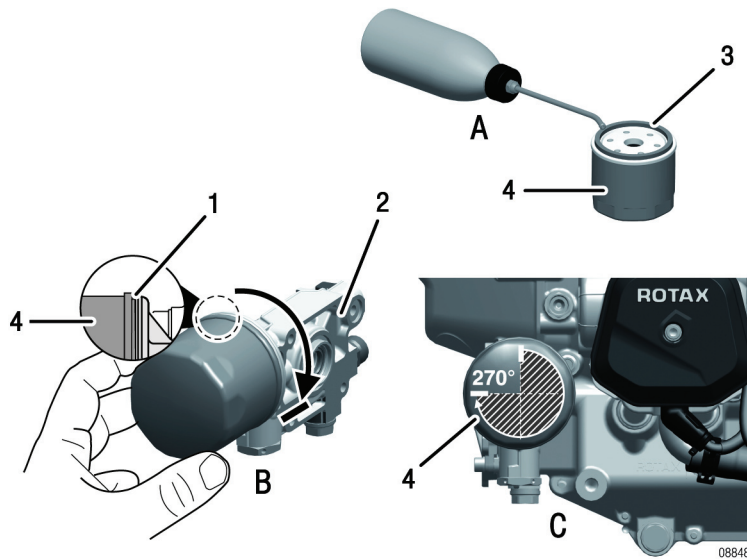

Part	Function
1	Contact surface
2	Oil pump housing
3	Gasket
4	Oil filter

Fig. 26

08550

d055661.fm

**BRP-Powertrain**  
MAINTENANCE MANUAL

**11.4) Inspection of the filter insert**

General note

**NOTICE**

The filter insert must be inspected carefully for metal chips.

This inspection is important as it allows conclusions to be drawn regarding the internal condition of the engine and provides information about the possible cause of any damage.

Procedure

To carry out the procedure the following steps are necessary:

Step	Procedure
1	Oil filter cut open using special tool taking care not to produce chips.
2	Remove filter insert.
3	Cut top and bottom edges off the mat with a knife.
4	Remove filter mat, fold up and press remaining oil out.
5	Unroll and inspect it for metal chips, foreign matter, contamination and abrasion.
6	Pass over matt with a clean magnet and inspect for metal.

Possible foreign matter

Steel chips	Bronze chips
Aluminium chips	Sliver of bearing material
Remains of sealing compound	Plastic (thrust washer)
Carbon fiber	Sliver of copper

Increased foreign matter

If an increased amount of metal particles is found, such as brass- or bronze chips or sliver from bearing abrasion, repair or overhaul the engine in accordance with the BRP-Powertrain instructions for continued airworthiness. If the filter mat is clogged by foreign matter, the lube oil reaches the bearing points unfiltered via the by-pass valve in the oil filter.

Unclear findings

In the case of unclear findings:

Step	Procedure
1	Flush the oil circuit.
2	Fit a new oil filter.
3	Engine test run. See chap. 12-20-00 section: 8).
4	Inspect the oil filter once more.

**BRP-Powertrain**  
**MAINTENANCE MANUAL**

Contaminated

**NOTICE**

If the oil circuit is contaminated, replace the oil cooler and flush the oil circuit. See chap. 12-20-00 section: 11.7). Proper judgement requires years of experience in repair of piston engines.

Graphic

Oil filter

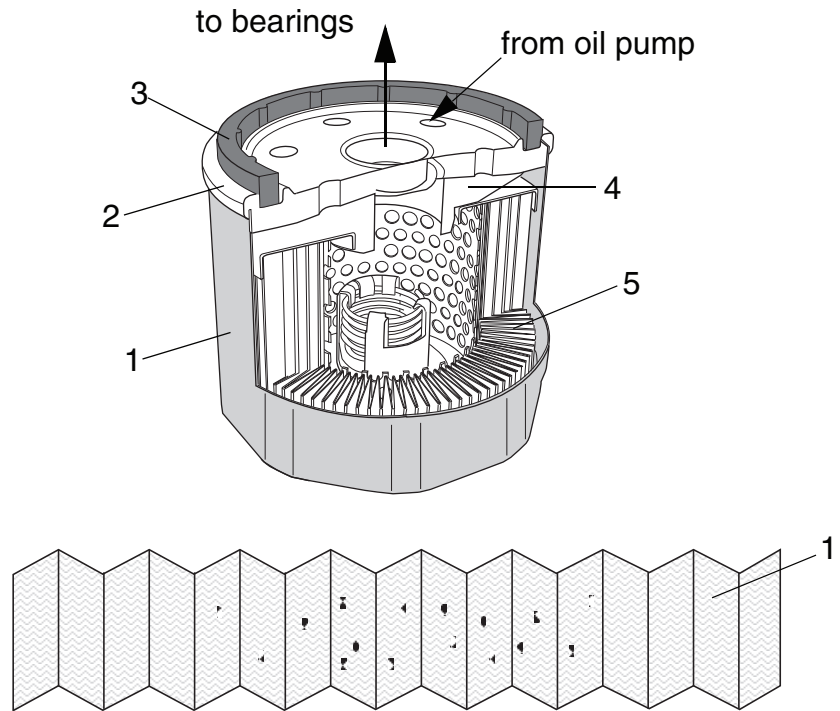

Part	Function
1	Filter housing
2	Filter cover
3	Gasket ring
4	Filter element
5	Filter mat

Fig. 27

08427,00181

d055661.fm

## 11.5) Cleaning the oil tank

See Fig. 28.

### Procedure

Procedure to clean the oil tank:

Step	Procedure
1	Detach the profile clamp (2) and remove the oil tank cover (3) together with the O-ring (4) and the oil lines.
2	Remove the inner parts of the oil tank such as the baffle insert (5) and the partition (6).
3	Clean oil tank (8) and inner parts (5, 6) and check for damage.

### NOTICE

Incorrect assembly of the oil tank components can cause engine faults or engine damage.

Step	Procedure
4	Fit hex.Double ignition screw (1) M12x12 with a new gasket ring (7). Tighten to 25 Nm (18.5 ft.lb).
5	Safety wire (9).
6	Reassemble the oil tank by following the same steps in reverse order.
7	Purge the oil system.

**BRP-Powertrain**  
 MAINTENANCE MANUAL

Graphic                      Cleaning the oil tank

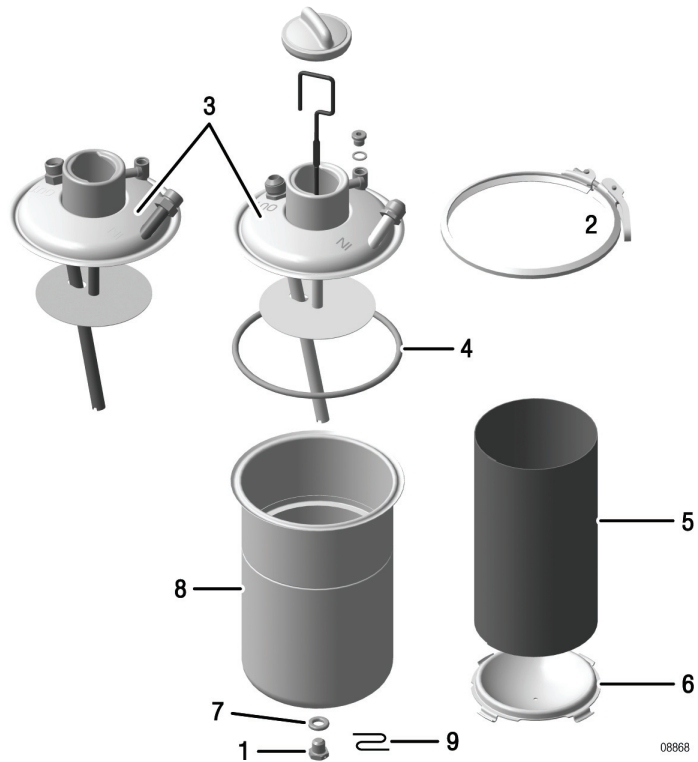

Part	Function
1	Hex. screw M12x12
2	Profile clamp
3	Oil tank cover
4	O-ring
5	Baffle insert
6	Partition
7	Gasket ring
8	Oil tank
9	Safety wire

*Fig. 28*

d055661.fm

## 11.6) Purging the oil system

**General note**

**NOTICE**

Purging of the oil system is extremely important for operation and service life of the engine and therefore the procedure must be followed meticulously. It must be carried out in accordance with SI-912-018, "Purging the lubrication system", latest issue.

**Procedure**

Purging the oil system is necessary:

- before each first start up (e.g. after overhaul)
- after maintenance work during which the lubrication system was opened and voided.
- when engine was cranked with open oil lines (e.g. during oil change).
- when oil system or oil lines were blown through with compressed air.

## 11.7) Flushing the oil circuit

**General note**

**⚠ WARNING**

Risk of electric shock!  
Switch off ignition and remove key! Disconnect negative terminal of aircraft battery.

**Oil lines**

Dismantle and flush oil lines as per instructions of the aircraft manufacturer.

**Oil tank**

Clean the oil tank.

**Temporary oil lines**

Temporary oil lines (only for flushing) must be fitted so that the oil cooler is not connected. The return line is routed into a separate, clean receptacle and not back to the oil tank.

NOTES:            Otherwise, metal chips could penetrate the radiator or oil tank during flushing.

**Filling**

Fill the oil tank with approx. 3 l (0.8 gal (US)) of engine oil.

**Procedure**

The following steps have to be carried out after refilling:

**NOTICE**

The oil level in the tank must not drop below the end of suction pipe, otherwise air will be sucked in again.

**BRP-Powertrain**  
MAINTENANCE MANUAL

Step	Procedure
1	Turn engine by hand in direction of engine rotation to return the oil from the oil tank into the engine and into the collection container. The procedure is complete when no more contamination can be discovered.
2	Control the oil captured during the rinsing process. The rinsing process is complete when no more contamination can be discovered.
3	Install cleaned oil lines and oil cooler according to the manufacturers instruction.
4	Install new oil filter and refill with oil.

Reconnect negative terminal of aircraft battery.

Purging of the oil system, see chap. 12-20-00 section: [11.6](#)).

**Equipment**

**NOTICE**

Inspect all the equipment in accordance with the Maintenance Manual of the aircraft manufacturer.

d055661.fm

**BRP-Powertrain**  
MAINTENANCE MANUAL

NOTES

## 12) Inspecting the magnetic plug

<b>General note</b>	See <a href="#">Fig. 29</a> .										
	<p>NOTES: The magnetic plug is located on the crankcase between cylinder 2 and gearbox.</p> <p>This inspection is important because it allows conclusions to be drawn on the internal condition of the gearbox and engine and reveals information about possible damage.</p>										
<b>Procedure</b>	Remove the magnetic plug and inspect it for accumulation of chips.										
<b>Steel chips in low numbers</b>	Steel chips in low numbers as depicted in <a href="#">Fig. 29</a> can be tolerated if the accumulation is below 3 mm (0.125 in).										
<b>Steel chips in larger numbers</b>	If there are larger accumulations of metal chips on the magnetic plug, the engine must be repaired or overhauled in accordance with the BRP-Powertrain instructions for continued airworthiness.										
<b>Unclear findings</b>	In the case of unclear findings:										
	<table border="1" style="width: 100%; border-collapse: collapse;"> <thead> <tr> <th style="text-align: center;">Step</th> <th style="text-align: center;">Procedure</th> </tr> </thead> <tbody> <tr> <td style="text-align: center;">1</td> <td>Flush the oil circuit.</td> </tr> <tr> <td style="text-align: center;">2</td> <td>Fit a new oil filter.</td> </tr> <tr> <td style="text-align: center;">3</td> <td>Engine test run. See chap. 12-20-00 section: <a href="#">8</a>).</td> </tr> <tr> <td style="text-align: center;">4</td> <td>Inspect the oil filter once more.</td> </tr> </tbody> </table>	Step	Procedure	1	Flush the oil circuit.	2	Fit a new oil filter.	3	Engine test run. See chap. 12-20-00 section: <a href="#">8</a> ).	4	Inspect the oil filter once more.
Step	Procedure										
1	Flush the oil circuit.										
2	Fit a new oil filter.										
3	Engine test run. See chap. 12-20-00 section: <a href="#">8</a> ).										
4	Inspect the oil filter once more.										
<b>Contamination</b>	<p style="background-color: #0056b3; color: white; padding: 5px; display: inline-block;"><b>NOTICE</b></p> <p>If the oil circuit is contaminated, replace the oil cooler and flush the oil circuit. See chap. 12-20-00 section: <a href="#">11.7</a>)<a href="#">11.7</a>). Detailed inspection of affected engine components.</p> <p>Trace the cause and remedy.</p>										

**BRP-Powertrain**  
**MAINTENANCE MANUAL**

**Graphic**

Inspecting the magnetic plug.

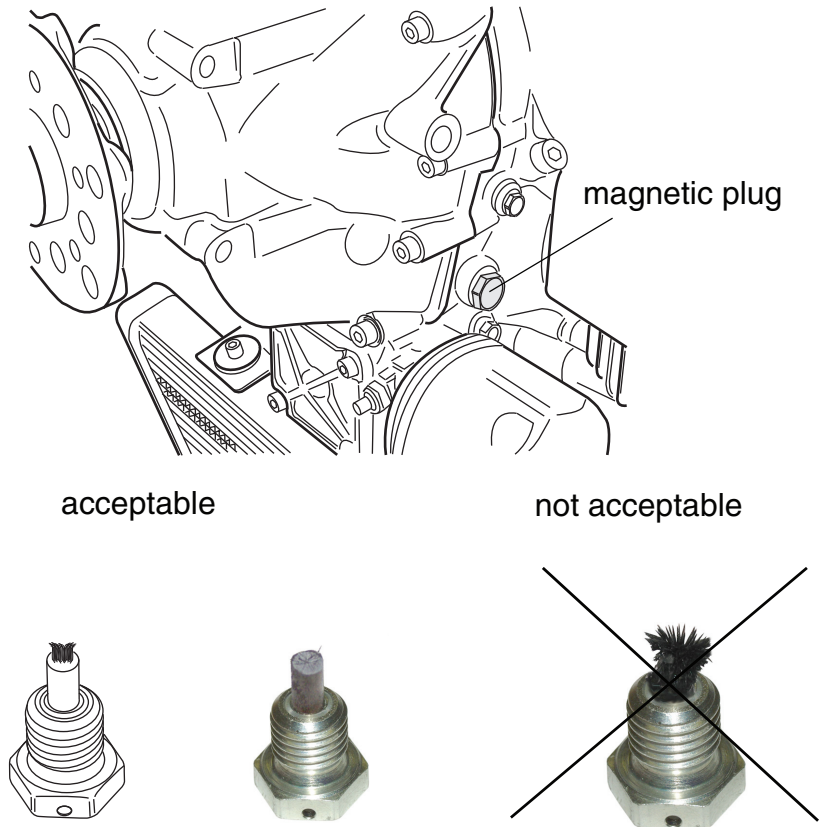

*Fig. 29*

08565,08566,08564,08563

**12.1) Installation of the magnetic plug**

**| Install**

The following steps are necessary:

Step	Procedure
1	Clean the magnetic plug and oil tank.
2	Install magnetic plug. Tightening torque 25 Nm (18 ft.lb)
3	Install safety wiring.

Inspect all system for correct function. Detailed inspection of affected engine components.

**BRP-Powertrain**  
**MAINTENANCE MANUAL**

**13) Electric system**

**Overview**

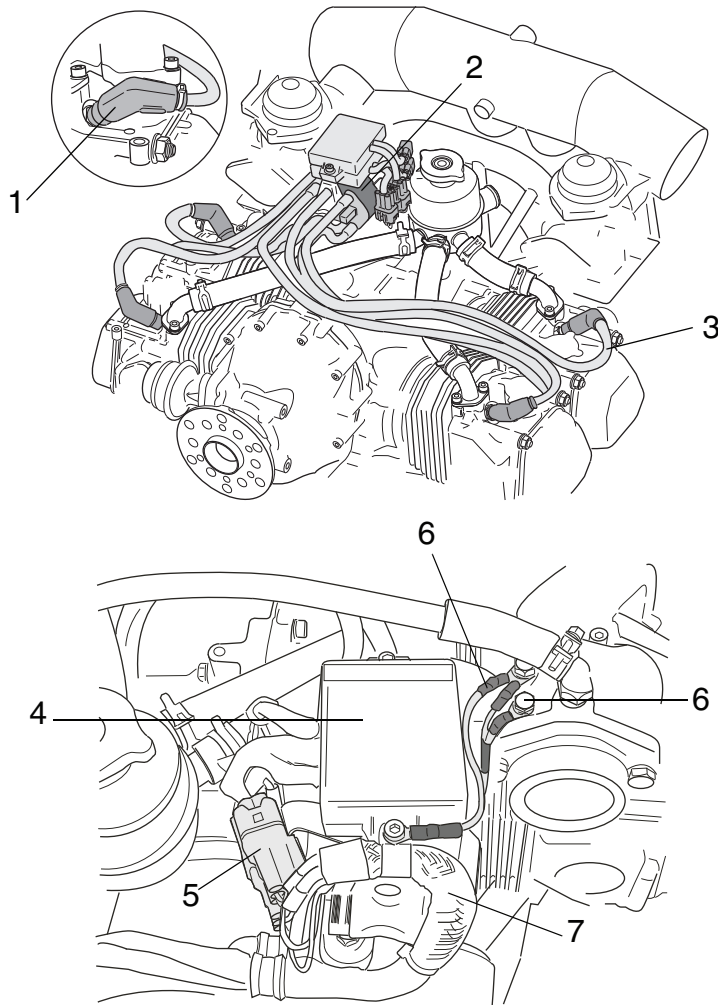

Part	Function
1	Spark plug connectors
2	Dual ignition coil
3	Ignition cable
4	Electronic module
5	Plug connectors
6	Grounding cable
7	Protection hose

*Fig. 30*

08552,08553

d05561.fm

**BRP-Powertrain**  
MAINTENANCE MANUAL

### 13.1) Check of wiring

**General note**



Risk of electric shock!  
Switch off ignition and remove key!



Risk of severe burns and scalds!  
Hot engine parts!  
Always allow engine to cool down to ambient temperature before start of any work.

**Procedure**

The following steps have to be carried out:

Step	Procedure
1	Inspect all cable connectors and their connections for tight fit, good contact, corrosion or damage and replace as necessary.
2	Inspect all ground connections for corrosion and damage, replace if necessary.
3	Inspect plug connections between pick-up cable, electronic module, charging and shorting cables for corrosion or damage and replace as required.
4	Inspect plug connections between electronic module and ignition coils for corrosion or damage and replace if necessary.
5	Verify plug connections of alternator cables with rectifier-regulator and connections of all cables on rectifier-regulator for good contact, tight fit, corrosion or damage and replace if necessary.
6	Inspect grounding cables for tight fit, corrosion or damage and replace if necessary.
7	Verify shielding of cable assemblies for corrosion or damage, good ground contact and tight fit, inspect the attachment of the shielding and replace if necessary.
8	Inspect all 8 ignition cables to spark plug connector for corrosion or damage and tight fit and replace if necessary.

## 13.2) Inspection and replacement of spark plugs

**General note** See Fig. 31.

**NOTICE**

Use of incorrect spark plugs can result in ignition problems and pre-ignition and consequent engine damage. See chap. 05-50-00 section: 3).

Because of the differing thermal load, particular spark plugs have been specified for each engine type.

In numerous tests the best possible heat range has been determined to make sure that the spark plug will burn off deposits but will not overheat.

**Renewal intervals** NOTES: Operation with leaded fuels (e.g. AVGAS 100LL) can result in increased wear of the spark plugs. Reduce renewal intervals accordingly.

**Special tool** Ensure that the following spark plugs corresponding to engine type are employed and that the correct spark plug socket is used:

Engine	Part no.	Designation	Size of socket
912 A/F/UL	897255	DCPR 7E	16 mm (0.63 in)
912 S/ULS	297940	DCPR 8E	16 mm (0.63 in)

### 13.2.1) Remove the spark plugs

**Remove** Remove the spark plugs and store them according to cylinder and position. Always replace both spark plugs of a cylinder and do not interchange spark plugs between cylinders.

**BRP-Powertrain**  
 MAINTENANCE MANUAL

**13.2.2) Inspection of spark plugs**

**Heat range**            Check heat range and adjust electrode gap correspondingly.

---

**Visual check**            Inspect all spark plugs for mechanical damage.

---

**Electrode gap**

<b>Electrode gap</b>	
<b>New</b>	<b>Wear limit</b>
0,6 - 0,7 mm (0.023 - 0.027 in)	0,9 mm (0.035 in)

NOTES:            Inspect the electrode gap also on use of new spark plugs.  
                          The distance can be changed by improper handling.

---

**Spark plug face**        Spark plug face reveals the following about the operating condition of the engine:

<b>Spark plug face</b>	<b>Information</b>
<b>light coloured to brown</b>	plug and calibration of the engine are correct
<b>velvet black</b>	Indicates the following: <ul style="list-style-type: none"> <li>- mixture too rich</li> <li>- insufficient air intake (clogged air filter)</li> <li>- engine operating temperature too low</li> </ul>
<b>oily, glossy coating</b>	Indicates the following: <ul style="list-style-type: none"> <li>- damaged valve stem seal</li> <li>- misfiring</li> <li>- too much oil in combustion chamber</li> <li>- worn cylinder and piston rings</li> </ul>
<b>white with formation of melt beads</b>	Indicates the following: <ul style="list-style-type: none"> <li>- mixture too lean</li> <li>- leaking valves</li> </ul>

---

### 13.2.3) Installation of spark plug

**Cleaning**



**WARNING**

Eyes and skin irritation!  
 Rinse off with water in the case of contact with eyes or skin. May be harmful if swallowed.

Before every installation, the spark plug thread and the spark plug seat at the cylinder head should be cleaned (e.g. to remove residue of heat conduction compound).

**Installation**

**NOTICE**

Always replace both spark plugs of a cylinder and do not interchange spark plugs between cylinders.

**NOTICE**

Heat conduction compound at the ground electrode (1) or the head area (2) can lead to ignition problems. Apply heat conduction compound sparingly and do not apply to the first three threads.

Apply small amount of heat conduction compound to spark plug thread and tighten spark plug to 20 Nm (177 in.lb) on the **cold** engine.

**Graphic**

spark plugs

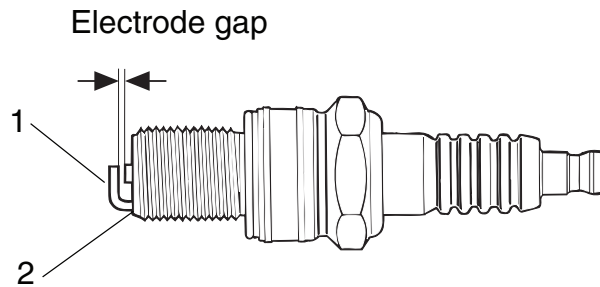

Part	Function
1	Ground electrode
2	Head area

*Fig. 31*

00086

d055661.fm

**BRP-Powertrain**  
MAINTENANCE MANUAL

NOTES

# BRP-Powertrain

## MAINTENANCE MANUAL

### 14) Propeller gearbox

**General note**      **NOTES:**      The following “free rotation check” and “friction torque check” are necessary only on engines with the overload clutch as optional extra.

**Engine without the overload clutch**      Engines without the overload clutch (slipper clutch) have no free rotation. For this reason the friction torque method cannot be applied on engines without overload clutch.

#### 14.1) Checking the friction torque in free rotation

**General note**      See Fig. 32.



**WARNING**

Risk of electric shock!

Switch off ignition and remove key! Disconnect negative terminal of aircraft battery.

**Test procedure**      The following steps are necessary for the testing procedure:

Step	Procedure
1	Fit the crankshaft locking pin. See chap. 12-20-00 section: 7).
2	With the crankshaft locked, the propeller can be turned by hand 15 or 30 degrees depending on the profile of the dog gears installed. This is the maximum amount of movement allowed by the dog gears in the torsional shock absorption unit.
3	Turn the propeller by hand back and forth between ramps, taking into consideration the friction torque. No odd noises or irregular resistance must be noticeable during this moment.
4	Attach a calibrated spring scale to the propeller in distance (L) from the center of the propeller. Measure the force required to pull the propeller through the 15 or 30 degree range of free rotation.
5	Calculate friction torque (Nm) by multiplying the force (N) obtained on the spring scale by the distance the scale is attached from the center of the propeller (L). The friction torque must be between 30 Nm and max. 60 Nm (22 to 44.3 ft.lb). See calculation example. <b>NOTICE</b> If the above mentioned friction torque is not achieved, inspect, repair or overhaul the gearbox in accordance with the instructions for continued airworthiness.
6	Remove crankshaft locking pin. See chap. 12-20-00 section: 7).

d05561.fm

**BRP-Powertrain**  
MAINTENANCE MANUAL

Graphic

Checking the friction torque.

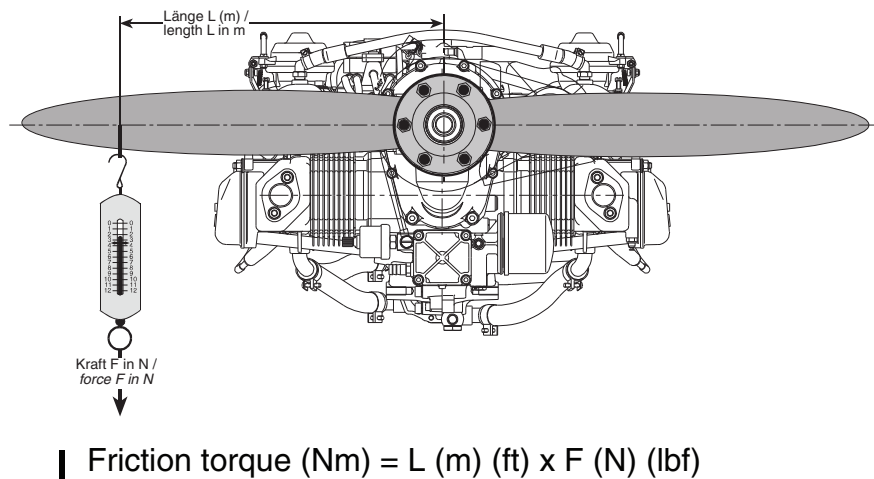

Fig. 32

05694

## 14.2) Checking the propeller gearbox

**General note**

The gearbox must be inspected, repaired or overhauled in accordance with the BRP-Powertrain instructions for continued airworthiness.

Detailed inspection of the affected gearbox components in accordance chap. 72-00-00 section: 3.9) in the Heavy Maintenance Manual.

Crack testing of the propeller shaft is not normally planned, but can be carried out if cracks are suspected.



---

Motornummer / Engine serial no.

---

Flugzeugtype / Type of aircraft

---

Flugzeugkennzeichen / Aircraft registration no.

ROTAX<sup>®</sup> Vertriebspartner

ROTAX<sup>®</sup> authorized distributor