

AVCO LYCOMING
PARTS CATALOG

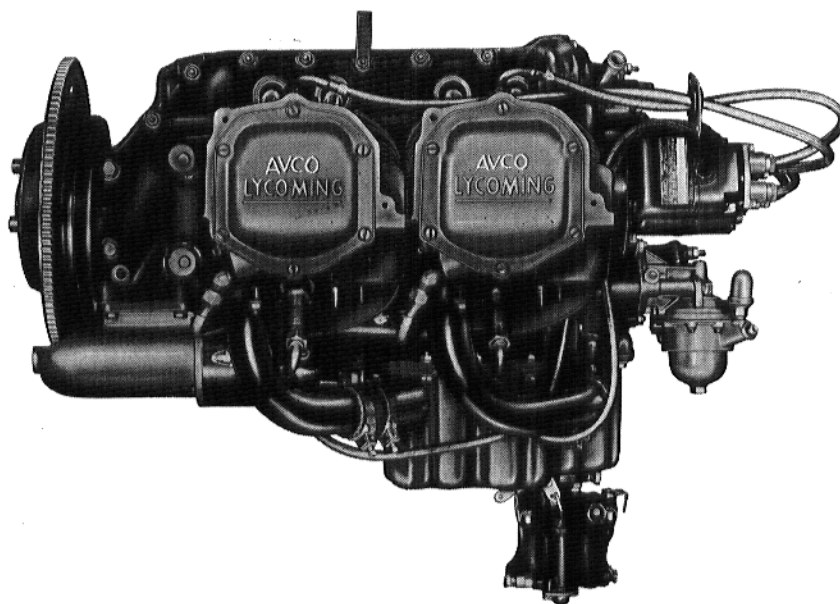

O-320, IO-320 & LIO-320
SERIES
AIRCRAFT ENGINES



LYCOMING DIVISION
WILLIAMSPORT, PA.

PC-103

Price \$12.00

April 1970

AVCO LYCOMING AIRCRAFT ENGINE GROUP ASSEMBLY PARTS LIST

O-320, IO-320, LIO-320 SERIES

INTRODUCTION

1. GENERAL.

This illustrated parts catalog lists and describes all procurable parts for the Avco Lycoming engines listed herein.

2. SUPERSEDURE SECTION.

This section lists part numbers in numerical sequence, first by superseded number to the new, or superseding part number. The second portion of this section lists the superseding, or new part number to the old or superseded number.

3. GROUP ASSEMBLY PARTS LISTS.

This catalog is laid out in graph format indicating engine model number on each text page.

The sections of this catalog divide the engine into various assemblies and related parts. These parts are listed in the order of engine assembly at the factory. Illustrations are on the page directly opposite or beneath the part description.

The "Figure Reference Number" column (with heading "REF") provides cross reference to the part illustration. Those parts not numbered in this column are not illustrated.

The "Part Number" column contains the Avco Lycoming, AN, MS, or vendor part number.

The "Description" column provides description or dimensional information required to describe the part. Sub-columns are employed here to differentiate parts of assemblies or sub-assemblies. Notes appearing in the text should be checked prior to ordering parts. All references to Avco Lycoming Service Bulletins, Instructions and Letters should be fully observed. The letters (STD) appearing beside the part description means this part fits an engine manufactured with the Standard cylinder base flange. The letters (WCF) means this part fits an engine manufactured with the wide cylinder base flange. When neither appears in the description column, the part is applicable to either configuration.

The "Quantity Per Assembly" portion of the text page indicates by model number the quantity required to complete the assembly on that page.

4. SERVICE REPLACEMENT SET SECTION.

This section consists of the seal and gasket set applicable to the O-320 series engine. Individual parts contained in kits are also listed in the group assembly parts list and may be procured separately.

5. VENDOR ITEMS SECTION.

This section consists of assemblies produced by manufacturers other than Avco Lycoming, for use on Avco Lycoming engines. Numbers in "Part Number" column are those of the particular vendor. Parts for these assemblies can be obtained by ordering from Avco Lycoming, Williamsport, Pa.

6. NUMERICAL INDEX.

This section lists all part numbers contained in the group assembly parts list (Sections 1 thru 7), in alphabetical sequence. Column headings are self-explanatory.

7. INSTRUCTIONS FOR ORDERING PARTS.

Use of this catalog is keyed to engine model number. The model number can best be determined by visual inspection of the name plate located on the oil sump. Series of engines identified by the letter "A" following the serial number suffix are manufactured with the wide cylinder base flange. Example: O-320-A, Serial Number L-12093-39A.

After engine model number and type cylinder flange is determined, look in the Table of Contents for the part, or for the assembly on which it would normally be found. If the part number is known, look in the numerical index (Section 10) in the back of the catalog. The illustrations can also be used to aid in finding the part.

8. OPTIONAL ITEMS.

Those optional items, such as electrical system components, vacuum and hydraulic dual drives etc., are catalogued by engine model number as the engine was assembled at the factory. See appropriate Service Instructions for further information. Use the illustrations to aid in determining the option you desire.

AVCO LYCOMING AIRCRAFT ENGINE GROUP ASSEMBLY PARTS LIST

O-320, IO-320, LIO-320 SERIES

TABLE OF CONTENTS

SECTION	PAGE
INTRODUCTION	i
TABLE OF CONTENTS	ii
SUPERSEDURE SECTION	iv
1. Crankcase, Crankshaft and Camshaft	
Crankcase Assembly	1-1
Crankcase Related Parts	1-2
Crankshaft Assembly	1-3
Connecting Rod	1-4
Camshaft	1-4
Crankcase Attaching Parts	1-5
Support Assembly, Starter Ring Gear	1-6
Accessory Idler Shafts	1-6
Propeller Flange and Spacer	1-6
Fuel Pump Drive and Idler Gears	1-7
2. Accessory Housings and Drives	
Accessory Housing - Separate Cam Gear	2-1
Accessory Housing - Integral Cam Gear	2-2
Oil Pump	2-3
Accessory Housing Attaching Parts	2-3
Oil Cooler and Oil Filter	2-4
Vacuum Pump Drive	2-5
Dual Drive, Vacuum Pump and Hydraulic Pump	2-5
Dual Drive, Vacuum Pump and Propeller Governor	2-5
Propeller Governor Drive Shaftgear	2-6
Cover, Vacuum Pump	2-6
Cover, Vacuum and Hydraulic Pump	2-6
Cover, Fuel Pump	2-6
Propeller Governor Drive Adapter	2-7
Cover, Governor Drive	2-7
Cover, Governor Drive Adapter	2-7
Sump Assembly	2-8
Sump Assembly	2-9
3. Cylinder, Piston and Valve Train	
Cylinder, Piston, Ring and Valve Application	3-1
Cylinder Assembly	3-2
Valve Seats and Guides	3-2
Spark Plug Inserts	3-2
Valves, Springs and Plungers	3-3
Shroud Tubes	3-3
Valve Rocker Assemblies	3-4
Valve Push Rods	3-4
Valve Rocker Drain Tubes	3-4
Intake Pipes	3-4
4. Ignition System	
Magnetos	4-1
Unshielded Harness	4-2
Harness Assy., 5MM, Avco Lycoming	4-3
Harness Assy., Scintilla, -1200 Series Magnetos	4-4
Harness Assy., Scintilla, -200 Series Magnetos	4-5
Harness Assy., Slick	4-6
Spark Plug	4-7
5. Electrical System	
Generator/Alternator Brackets, Standard Cylinder Flange Engines	5-1
Generator/Alternator Brackets, Wide Cylinder Flange Engines	5-2

AVCO LYCOMING AIRCRAFT ENGINE GROUP ASSEMBLY PARTS LIST

G-320, IO-320, LIO-320 SERIES

TABLE OF CONTENTS (CONT.)

SECTION		PAGE
5.	Electrical System (Cont.)	
	Generator/Alternator	5-3
	Generator/Alternator Drive Belt.	5-4
	Starter	5-4
	Magnetic Switch	5-4
	Voltage Regulator and Relay	5-5
6.	Fuel Induction System	
	Fuel Pump	6-1
	Carburetor	6-2
	Fuel Injector	6-3
	Fuel Injection Tubes.	6-4
	Priming System	6-5
7.	Cooling Baffles, Exhaust, Oil Gage and Propeller Governor Oil Line	
	Intercylinder Cooling Baffles	7-1
	Exhaust Flanges and Gaskets	7-2
	Oil Level Gages	7-3
	Propeller Governor Oil Line	7-4
8.	Service Replacement Set Section.	8-1
9.	Vendor Accessories	
	Delco-Remy Generator	9-1
	Delco-Remy Alternator.	9-2
	Prestolite Alternator	9-3
	Prestolite Starter.	9-4
	Bendix Scintilla Magnetos:	
	-20 Series	9-5
	-200 Series.	9-6
	-1200 Series	9-7
	Lear-Siegler Fuel Pump	9-8
	Marvel-Schebler Carburetor	9-9
	Bendix Fuel Injector.	9-10
10.	Numerical Index	10-1

AVCO LYCOMING AIRCRAFT ENGINE GROUP ASSEMBLY PARTS LIST

AVCO LYCOMING PARTS CATALOG

O-320, IO-320 AND LIO-320 SERIES

SUPERSEDURE SECTION

Supersedures

iii B

AVCO LYCOMING AIRCRAFT ENGINE GROUP ASSEMBLY PARTS LIST

SUPERSEDED PARTS

SUPERSEDED P/N	SUPERSEDING P/N	SUPERSEDED P/N	SUPERSEDING P/N
180G	72378	69472	73414
179B	72053	69529	72877
STD-189	73726	69530	72058
STD-336	72075	69533	74230
STD-998	72091	69787	72500
45663	62224	69952	76210
60007	74667	71010	75722
60069	73346	71019	72501
60131	71973	71026	72502
60828	72198	71118	71840
60861	76028	71119	71841
60869	71596	71692	72153
60984	76354	71693	71844
61152	75072	71714	76529
61154	77309	71840	75183
61164	72970	71841	75184
61167	68974	71844	73149
61246	75906	71879	76940
61278	74996	71939	74673
61352	73818	71950	74646
61388	62833	71969	75188
61476-S	78030-S	72059	74068
61502	71398	72220	74065
61654	73246	72362	77965
61667	71397	72373	75767
61864	73817	72387	76517
62831	72205	72394	78728
65060	66224	72446	74241
65074	78524	72454	73857
65331	71909	72454	73998
65427	76994	72462	76212
66144	72078	72525	73360
66220	71913	72625	73938
66734	69377	72871	72000
67904	72057	73048	77034
67975	73729	73049	LW-10124
68327	LW-10077	73115	LW-10076
68509	72454	73160	LW-10799
68512	74989	73149	75361
68513	74989	73196	74059
68519	69444	73817	72829
68531	75545	73820	78292
68613	72079	74059	75413
68634	72498	74061	68512
68710	77857	74061	68513
68749	72230	74083	LW-10828
68751	69679	74092	76211
68759	73317	74322	76026
68769	74167	74386	75278
68867	74414	74530	75089
68923	72150	74591	LW-10475
68987	75772	74593	74732
69000	75153	74667	78027
69097	75735	74904	76691
69098	75736	75009	77547
69158	72231	75028	75012
69161	75924	75044	75317
69315	73231	75044	75042
69451	75944	75065	75010
69470	73412	75067	75011
69470-1	73411	75148	75246
69471	73413	75210	77044

AVCO LYCOMING AIRCRAFT ENGINE GROUP ASSEMBLY PARTS LIST

SUPERSEDED PARTS

SUPERSEDED P/N	SUPERSEDING P/N	SUPERSEDED P/N	SUPERSEDING P/N
75317	75868	76907	LW-10729
75674	77526	76954	78206
75709	78368	76991	78542
75854	75907	76992	78539
76082	77597	76995	78540
76163	77808	77096	78547
76290	78290	77344	78308
76436	76628	77345	LW-10185
76588	78217	77346	78312
76590	78220	77347	LW-10179
76602	78221	77470	78310
76721	LW-10389	77751	78314
76722	LW-10388	78206	LW-11062
76726	LW-10400	78218	78226
76855	LW-10390	78219	78228
76871	78546		

AVCO LYCOMING AIRCRAFT ENGINE GROUP ASSEMBLY PARTS LIST

SUPERSEDED PARTS

SUPERSEDING P/N	SUPERSEDED P/N	SUPERSEDING P/N	SUPERSEDED P/N
62224	45663	74230	69533
62833	61388	74241	72446
66224	65060	74414	68867
68512	74061	74646	71950
68513	74061	74667	60007
68974	61167	74673	71939
69377	66734	74732	74593
69444	68519	74989	68512
69679	68751	74989	68513
71397	61667	74996	61278
71398	61502	75010	75065
71596	60869	75011	75067
71840	71118	75012	75028
71841	71119	75042	75044
71844	71693	75072	61152
71909	65331	75089	74530
71913	66220	75153	69000
71973	60131	75183	71840
72000	72871	75184	71841
72053	179B	75188	71969
72057	67904	75246	75148
72058	69530	75278	74386
72075	STD-336	75317	75044
72078	66144	75361	73149
72079	68613	75413	74059
72091	STD-998	75545	68531
72150	68923	75722	71010
72153	71692	75735	69097
72198	60828	75736	69098
72205	62831	75767	72373
72230	68749	75772	68987
72231	69158	75868	75317
72378	180G	75906	61246
72454	68509	75907	75854
72498	68634	75924	69161
72500	69787	75944	69451
72501	71019	76026	74322
72502	71026	76028	60861
72829	73817	76210	69952
72877	69529	76211	74092
72970	61164	76212	72462
73149	71844	76354	60984
73231	69315	76517	72387
73246	61654	76529	71714
73317	68759	76628	76436
73346	60069	76691	74904
73360	72525	76940	71879
73411	69470-1	76994	65427
73412	69470	77034	73048
73413	69471	77044	75210
73414	69472	77309	61154
73726	STD-189	77526	75674
73729	67975	77547	75009
73817	61864	77597	76082
73818	61352	77808	76163
73857	72454	77857	68710
73938	72625	77965	72362
73998	72454	78027	74667
74059	73196	78030-S	61476-S
74065	72220	78206	76954
74068	72059	78217	76588
74167	68769	78220	76590

AVCO LYCOMING AIRCRAFT ENGINE GROUP ASSEMBLY PARTS LIST

SUPERSEDED PARTS

SUPERSEDING P/N	SUPERSEDED P/N	SUPERSEDING P/N	SUPERSEDED P/N
78221	76602	78728	72394
78226	78218	LW-10076	73115
78228	78219	LW-10077	68327
78290	76290	LW-10124	73049
78292	73820	LW-10179	77347
78308	77344	LW-10185	77345
78310	77470	LW-10388	76722
78312	77346	LW-10389	76721
78314	77751	LW-10390	76855
78368	75709	LW-10400	76726
78524	65074	LW-10475	74591
78539	76992	LW-10729	76907
78540	76995	LW-10799	73160
78542	76991	LW-10828	74083
78546	76871	LW-11062	78206
78547	77096		

TECHNICAL PUBLICATION SUPPLEMENT

SUPPLEMENT No. SSP-488	ENGINE MODEL O-320, IO-320 and LIO-320 Series	PUBLICATION No. PC-103	PUBLICATION DATE April, 1970
---------------------------	---	---------------------------	---------------------------------

This supplement is arranged in the same basic format as the original parts catalog
Insert in front of catalog for usage of subject matter.

August, 1988
Page 1 of 1
Figure 1-3, Crankshaft Assembly

Superseded Engine Model	Propeller Bushings	Superseded By	Engine Model	Propeller Bushings
O-320* <small>No Letter Designation</small>	3/8 inch	-----	O-320-A3A**	7/16 inch
O-320-A1A	3/8 inch	-----	O-320-A3A**	7/16 inch
O-320-A1B	3/8 inch	-----	O-320-A3B**	7/16 inch
O-320-B1A	3/8 inch	-----	O-320-B3A**	7/16 inch
O-320-B1B	3/8 inch	-----	O-320-B3B**	7/16 inch

* Same as O-320-A1A.

** Parts for this engine are currently listed in PC-103 Parts Catalog dated April, 1970.

NOTE

This supplemental parts list and illustration provides an engine parts comparison between current and superseded engine models.

All parts for engine models in the above chart marked with an asterisk (*) are the same as parts for the superseded engine models with the exception of the Crankshaft Assy. and propeller mounting bushings and locations.

SECTION

1

**CRANKCASE,
CRANKSHAFT AND
CAMSHAFT GROUP**

AVCO LYCOMING PARTS CATALOG

O-320, IO-320 AND LIO-320 SERIES

SECTION 1

CRANKCASE, CRANKSHAFT AND CAMSHAFT

REF. NO.	PART NUMBER	1	2	3	4	5	DESCRIPTION	QTY. PER ENG.
-------------	----------------	---	---	---	---	---	-------------	---------------------

Page 1-1

	LW-11026						CRANKCASE ASSEMBLY	1
4	50-15						STUD, 1/2-20 x 1-7/8 in. long	8
5	38-13						STUD, 3/8-16 x 1-5/8 in. long	16
	38-22						STUD, 3/8-16 x 2-3/4 in. long	1
	72158						BUSHING, Gov. drive idler shaft	1
8	1102						PLUG, Allen, 1/8-27 NPT	5
	STD-1339						PLUG, Allen, 1/16-27 NPT	1
	68316						STUD, 5/16-18 x 1-11/16 in. long (Driven height of studs 0.96-1.00 in. for crankcase service assembly)	4

For all other parts applicable to IO-320-D1B use
column under IO-320-C1A except figure reference
numbers 6, 7, 17 and 18.

CRANKCASE ASSEMBLY

QUANTITY PER ASSEMBLY

SECTION

1 PAGE

1-1

REF.	PART NUMBER	DESCRIPTION	O-320 SERIES																		10-320			L10-320						
			A2A	A2B	A2C	A3A	A3B	A3C	B2A	B2B	B3A	B3B	B3C	D1A	D2A	D2B	D2C	E1A	E2A	E2B	E2C	E2D	B7A	B7C	C1A	D1A	E2A	B7A	C1A	
	78217*	CRANKCASE ASSY. - STD	1	1	1	1	1	1	1																					
	78222*	CRANKCASE ASSY. - WCF		1		1	1																							
	78226*	CRANKCASE ASSY. - STD								1	1	1	1						1	1									1	
	78223**	CRANKCASE ASSY. - WCF																												
	78220**	CRANKCASE ASSY. - STD														1	1		1	1	1	1					1			
	78228**	CRANKCASE ASSY. - STD																												
	78206**	CRANKCASE ASSY. - WCF																												
	78221+	CRANKCASE ASSY. - STD																												
	78224+	CRANKCASE ASSY. - WCF																												
	LW-11025+	CRANKCASE ASSY. - WCF (Note 1)																												
	LW-11078+	CRANKCASE ASSY. - WCF																												
	LW-11237+	CRANKCASE ASSY. - WCF (Note 2)																												
	LW-11305+	CRANKCASE ASSY. - WCF (Note 1)																												
	LW-11062**	CRANKCASE ASSY. - WCF (Note 3)																												
1	STD-557	DOWEL, 1/2 in. dia. x 11/16 in. long	2	2	2	2	2	2	2	2	2	2	2	2	2	2	2	2	2	2	2	2								
2	69377	STUD, 1/2-13 x 9-11/16 in. long - STD	2	2	2	2	2	2																						
2	75154	STUD, 1/2-13 x 10-1/32 in. long - WCF	2	2	2	2	2																							
2	66734	STUD, 1/2-13 x 9-7/8 in. long - STD	2	2	2	2	2																							
3	69377	STUD, 1/2-13 x 9-11/16 in. long - STD	2	2	2	2	2																							
3	66734	STUD, 1/2-13 x 9-7/8 in. long - STD	2	2	2	2	2																							
3	75154	STUD, 1/2-13 x 10.02 in. long - WCF	2	2	2	2																								
4	50-14	STUD, 1/2-13 x 1-3/4 in. long - STD	8	8	8	8	8																							
4	50-15	STUD, 1/2-13 x 1-7/8 in. long - STD								8	8	8	8	8	8	8	8													
4	50-16	STUD, 1/2-30 x 2.00 in. long - WCF				8	8	8																						
5	1025-B	STUD, 3/8-16 x 1-1/2 in. long - STD	16	16	16	16	16																							
5	38-13	STUD, 3/8-16 x 1-5/8 in. long - STD								16	16	16	16	16	16	16	16													
5	38-14	STUD, 3/8-16 x 1-3/4 in. long - WCF				16	16	16																						
6	69376¢	STUD, 1/2-20 x 10-17/64 in. long - STD	2	2	2	2	2	2																						
6	69679¢	STUD, 1/2-20 x 10-21/32 in. long - STD																												
6	75155¢	STUD, 1/2-20 x 10-15/16 in. long - WCF																												
7	75302¢	DOWEL, Crankcase thru stud - WCF	2	2	2	2																								
8	STD-1102	PLUG, 1/8-27 NPT	5	5	5	5	5	5	5	5	5	5	5	5	5	5	5	5	5	5	5	5								
9	65007	RETAINER, Shroud tube seal	8	8	8	8	8	8	8	8	8	8	8	8	8	8	8	8	8	8	8	8								
10	61261	STUD, 5/16-18 x 1-1/2 in. long	2	2	2	2	2	2	2	2	2	2	2	2	2	2	2	2	2	2	2	2								
11	67528	STUD, 5/16-18 x 1-5/8 in. long	1	1	1	1	1	1	1	1	1	1	1	1	1	1	1	1	1	1	1	1								
12	69796	DOWEL, Crankshaft bearing - WCF	6	6	6																									
12	69796	DOWEL, Crankshaft bearing - WCF																												
12	69796	DOWEL, Crankshaft bearing - WCF (See Note 1)																												
12	LW-10647	DOWEL, Crankshaft bearing - WCF (See Note 1)																												
12	67453	DOWEL, Crankshaft bearing - STD	6	6	6	6	6	6	6	6	6	6	6	6	6	6	6	6	6	6	6	6								
13	STD-514	DOWEL, 5/16 dia. x 1/2 in. long	2	2	2	2	2	2	2	2	2	2	2	2	2	2	2	2	2	2	2	2								
14	STD-1623	INSERT, 1/4-20 helicoil x 3/8 in.	2	2	2	2	2	2	2	2	2	2	2	2	2	2	2	2	2	2	2	2								
15	38D-17	STUD, 3/8-16 x 2-1/8 in. long - WCF	1	1	1	1																								
16	75156	STUD, 5/8-18 x 15/16 in. long - WCF	1	1	1																									
17	73772	NOZZLE ASSY., Piston cooling - WCF																												
18	STD-783#	PLUG, 1/4-28 NPT, Allen	1	1	1	1	1	1	1	1	1	1	1	1	1	1	1	1	1	1	1	1								
19	71032*	BUSHING, Engine support	8	8	8	8	8	8	8	8	8	8	8	8																
20	STD-619*	WASHER, Support bushing	8	8	8	8	8	8	8	8	8	8	8																	
21	61387&	SLEEVE, Oil relief valve	1	1	1	1	1	1	1	1	1	1	1	1	1	1	1	1	1	1	1	1								

* - Conical mounting.

** - Type 1 dynafocal mounting.

+ - Type 2 dynafocal mounting.

¢ - See Service Bulletin No. 273.

- For engines without governor drive.

& - For crankcases with no provision for adjustable oil pressure relief valve. (Available in oversize P03).

NOTE 1

Crankcases LW-11025 and LW-11305 use 2 69796 crankshaft bearing dowels and 4 LW-10647 dowels. All others use 6 69796 dowels.

NOTE 2

Crankcase LW-11237 is no longer available. Order LW-11305.

NOTE 3

Ref. 2 - stud 75154. Ref. 6 - 75155 not used this crankcase. See page 1-5 for attaching bolts 76220. Ref. 4 - use stud 50-15 8 ea. and Ref. 5 - use stud 38-13, 16 ea.

B

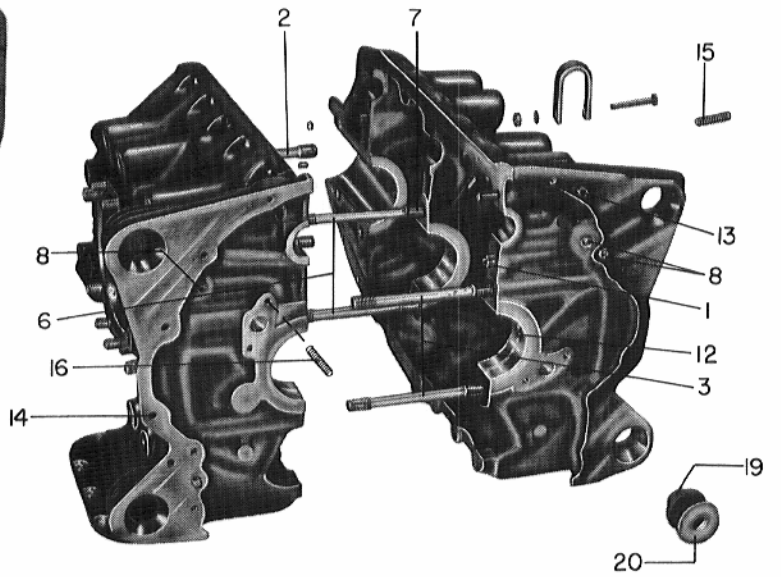
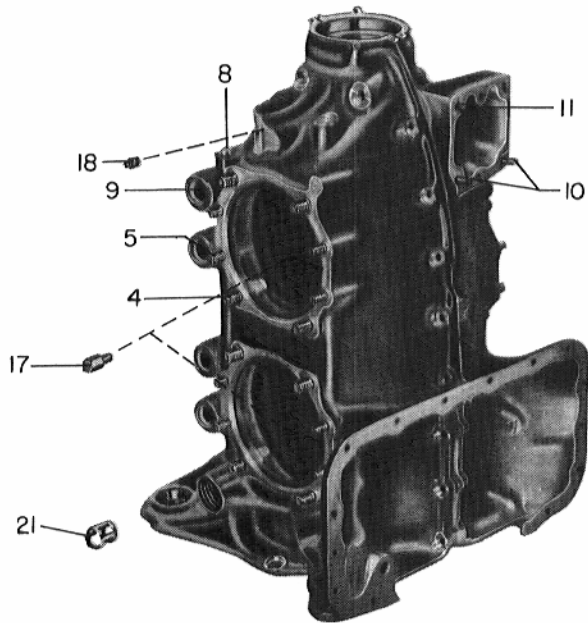
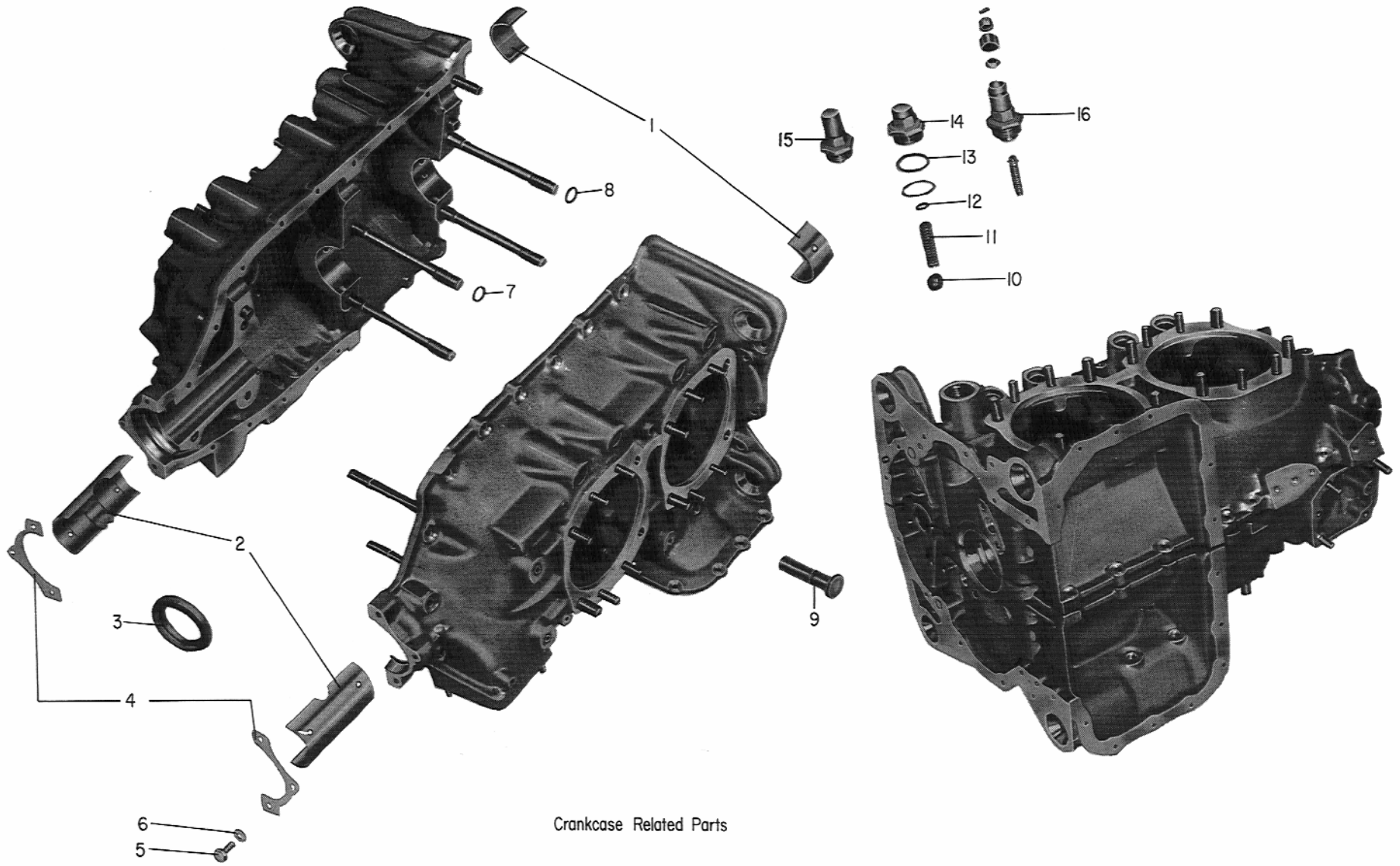

Figure 1-1. Crankcase Assembly

Figure 1-2. Crankcase Related Parts



Crankcase Related Parts

Williamsport Plant

CRANKCASE, CRANKSHAFT AND CAMSHAFT GROUP
CRANKSHAFT AND RELATED PARTS

FIG. REF. 1-3	PART NUMBER	DESCRIPTION	QUANTITY PER ASSEMBLY																	
			O-320, O-320-A1A, A1B, B1A and B1B																	
1	68864 *	CRANKSHAFT ASSEMBLY	1																	
2	STD-1211	PLUG, 2.00 dia. expansion	1																	
3	72066-S	BUSHING, Propeller flange, index	1																	
4	72067-S	BUSHING, Propeller flange	3																	
5	72068-S	BUSHING, Propeller flange, short	2																	
6	61510	PLUG, 1-3/4 O.D.	1																	

* No longer available. Order Crankshaft Assembly Part No. 75011 as a replacement. Refer to latest edition of Service Instruction No. 1098 for bushing application.

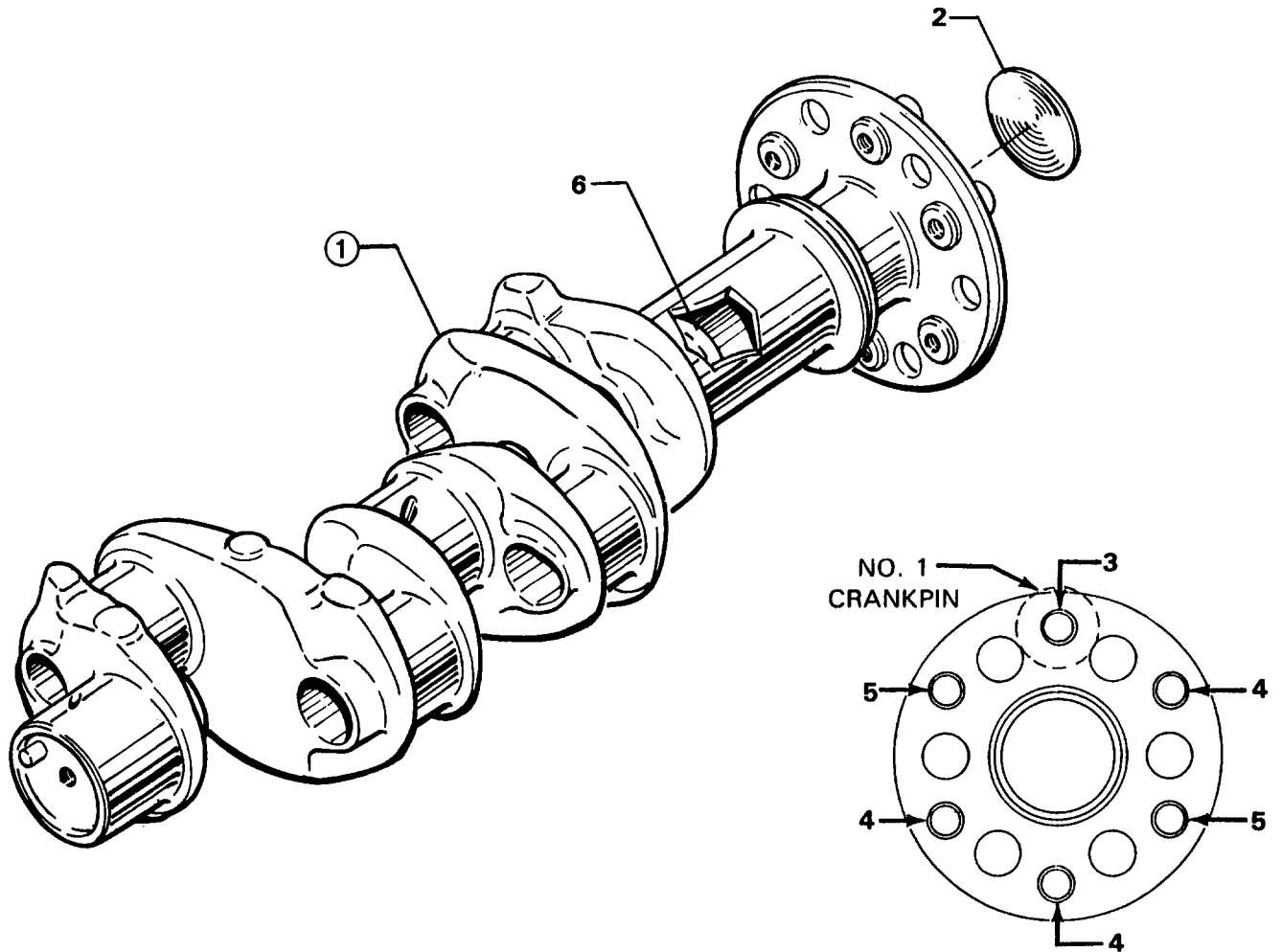

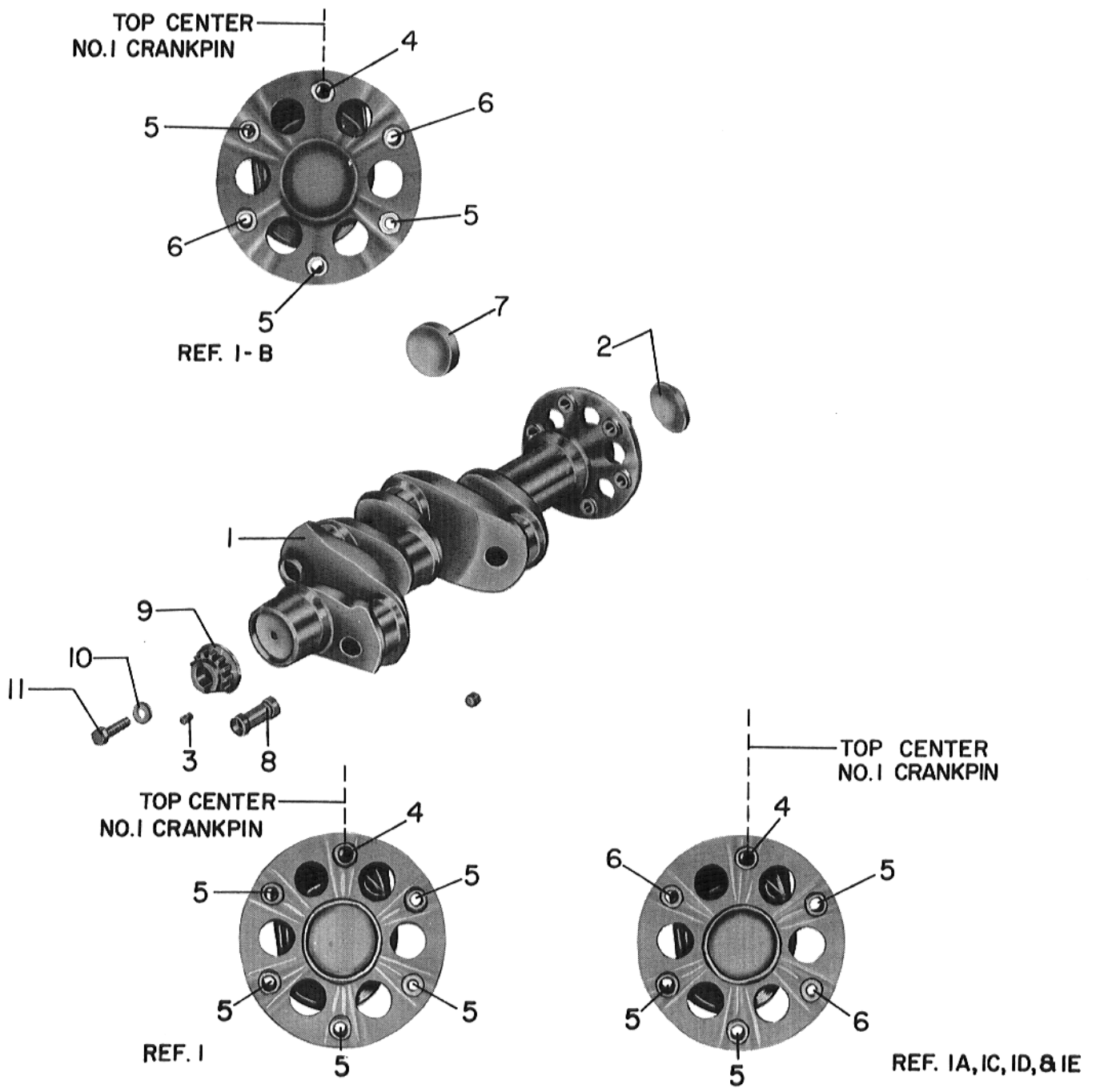

Figure 1-3. Crankshaft Assembly

Page 1-4

Figure references No. 1, P/N 61476-S and No. 3,
P/N 74667 do not apply to IO-320-D1B model engines.

6	78717	CAMSHAFT ASSEMBLY	1
---	-------	-------------------	---

NOTE

Figure reference numbers 7 thru 12 do not apply
to IO-320-D1B model engines.

Page 1-5

1	AN6-34A	BOLT, Hex. hd., 3/8-24 x 3-37/64 in. long	1
1	STD-33	WASHER, Plain, 3/8 in.	2
2	STD-8	WASHER, Plain, 1/4 in.	19
2	STD-160	WASHER, Internal lock, 1/4 in.	12
2	STD-1411	NUT, Plain, 1/4-20	9
7	AN960-616L	WASHER, Plain, 3/8 in. (thick). Max. 3 pcs.	AR
10	76220	STUD, 1/2-20 x 10-45/64 in. long	4

For other crankcase attaching parts except those listed above, use column headed IO-320-D1A. Item 10 does not apply to IO-320-D1B model engines.

SUPPORT ASSEMBLY AND IDLER SHAFTS

SECTION

QUANTITY PER ASSEMBLY

1
PAGE
1-6

REF.	PART NUMBER	DESCRIPTION	O-320 SERIES																		IO-320			L10-320						
			A2A	A2B	A2C	A3A	A3B	A3C	E2A	E2B	E3A	E3B	E3C	E2D	D1A	D2A	D2B	D2C	E1A	E1B	E1C	E1D	B1A	B1C	C1A	D1A	E2A	B1A	C1A	
1	68867	SUPPORT ASSY., Starter ring gear 10/12 pitch, 1.91:1 drive - STD	1	1		1	1	1	1	1	1	1	1	1	1	1	1	1	1	1	1									
1	68867	SUPPORT ASSY., Starter ring gear 10/12 pitch, 1.91:1 drive - WCF		1																	1									
1	68942*	SUPPORT ASSY., Starter ring gear 10/12 pitch, 1.91:1 drive - STD	1	1																	1									
1	74414	SUPPORT ASSY., Starter ring gear 12/14 pitch, 1.91:1 drive - STD	1	1		1	1	1	1	1	1	1	1	1	1	1	1	1	1	1										
1	74414	SUPPORT ASSY., Starter ring gear 12/14 pitch, 1.91:1 drive - WCF		1		1	1	1			1	1	1	1	1	1	1	1	1	1						1	1	1		
1	76628	SUPPORT ASSY., Starter ring gear 12/14 pitch, 3.25:1 alt. drive - WCF		1							1	1	1	1	1	1	1	1	1	1					1	1	1	1		
1	76899	SUPPORT ASSY., Starter ring gear 10/12 pitch, 3.25:1 alt. drive - WCF		1																	1									
1	76944	SUPPORT ASSY., Starter ring gear 10/12 pitch, 3.25:1 drive - WCF		1			1																							
1	LW-10552	SUPPORT ASSY., Starter ring gear 12/14 pitch, 3.25:1 alt. drive - WCF																												
2	60882	GEAR, Starter ring 10/12 pitch	1	1		1	1	1	1	1	1	1	1	1	1	1	1	1	1	1										
2	72566	GEAR, Starter ring 12/14 pitch	1	1		1	1	1	1	1	1	1	1	1	1	1	1	1	1	1					1	1	1	1		
2	LW-10551	GEAR, Starter ring 12/14 pitch																												
3	68939**	SPACER, Propeller hub - STD	1	1																										
4	45688+	FLANGE, Propeller - STD	1	1																	1									
5	STD-33+	WASHER, 3/8 plain - STD	6	6																	6									
6	STD-1198+	BOLT, 3/8-24 x 4.44 long - STD	6	6																	6									
7	68639C	GEAR, Camshaft	1	1		1	1	1	1	1	1	1	1	1	1	1	1	1	1	1	1	1	1	1	1	1	1	1	1	
8	68757C	SHAFT, Tachometer	1	1		1	1	1	1	1	1	1	1	1	1	1	1	1	1	1	1	1	1	1	1	1	1	1	1	
9	STD-1199C	PIN, 3/16 dia.	1	1		1	1	1	1	1	1	1	1	1	1	1	1	1	1	1	1	1	1	1	1	1	1	1	1	
10	68753C	SPACER, Tach. shaft	1	1		1	1	1	1	1	1	1	1	1	1	1	1	1	1	1	1	1	1	1	1	1	1	1	1	
11	72079C	SLINGER, Breather	1	1		1	1	1	1	1	1	1	1	1	1	1	1	1	1	1	1	1	1	1	1	1	1	1	1	
12	72078C	LOCKPLATE, 5/16 bolt	2	2		2	2	2	2	2	2	2	2	2	2	2	2	2	2	2	2	2	2	2	2	2	2	2	2	
13	STD-1791C	BOLT, 5/16-24 x .66 long	4	4		4	4	4	4	4	4	4	4	4	4	4	4	4	4	4	4	4	4	4	4	4	4	4	4	
8	76121#	SHAFT, Tachometer	1	1		1	1	1	1	1	1	1	1	1	1	1	1	1	1	1	1	1	1	1	1	1	1	1	1	
9	78368#	PIN, 3/16 x 2.33 in. long	1	1		1	1	1	1	1	1	1	1	1	1	1	1	1	1	1	1	1	1	1	1	1	1	1	1	
10	76118#	SPACER, Tach. shaft	1	1		1	1	1	1	1	1	1	1	1	1	1	1	1	1	1	1	1	1	1	1	1	1	1	1	
14	MS16625-1081#	RING, Internal retaining	1	1		1	1	1	1	1	1	1	1	1	1	1	1	1	1	1	1	1	1	1	1	1	1	1	1	
15	75158	SHAFT, Crankshaft idler - WCF	2	2		2	2	2	2	2	2	2	2	2	2	2	2	2	2	2	2	2	2	2	2	2	2	2	2	
16	71646	LOCKPLATE, 5/16 bolt - WCF	2	2		2	2	2	2	2	2	2	2	2	2	2	2	2	2	2	2	2	2	2	2	2	2	2	2	
17	STD-1826	BOLT, 5/16-18 x .67 long - WCF	3	3		3	3	3	3	3	3	3	3	3	3	3	3	3	3	3	3	3	3	3	3	3	3	3	3	
18	STD-1410	NUT, 5/16-18 plain - WCF	1	1		1	1	1	1	1	1	1	1	1	1	1	1	1	1	1	1	1	1	1	1	1	1	1	1	
15	68749	SHAFT, Crankshaft idler - STD	2	2		2	2	2	2	2	2	2	2	2	2	2	2	2	2	2	2	2	2	2	2	2	2	2	2	
16	73817	LOCKPLATE, 1/4 in. bolt - STD	2	2		2	2	2	2	2	2	2	2	2	2	2	2	2	2	2	2	2	2	2	2	2	2	2	2	
17	STD-705	SCREW, 1/4-20 x .69 long - STD	4	4		4	4	4	4	4	4	4	4	4	4	4	4	4	4	4	4	4	4	4	4	4	4	4	4	

* - Less spinner holes.
 ** - Required when no starter ring gear support is used.
 + - For fixed pitch installation only.
 C - Use on all engines incorporating removable camshaft gear.
 # - Use on all engines incorporating integral camshaft and gear.

NOTE
 10/12 pitch ring gears have 122 teeth.
 12/14 pitch ring gears have 149 teeth.
 See latest Service Instruction No. 1121 and 1141.

REF. NO.	PART NUMBER	DESCRIPTION	1	2	3	4	5	QTY. PER ENG.
----------	-------------	-------------	---	---	---	---	---	---------------

NOTE

Figure reference numbers 3 thru 13 do not apply to IO-320-D1B model engines.

Use column headed IO-320-D1A for all other parts listed on Page 1-6.

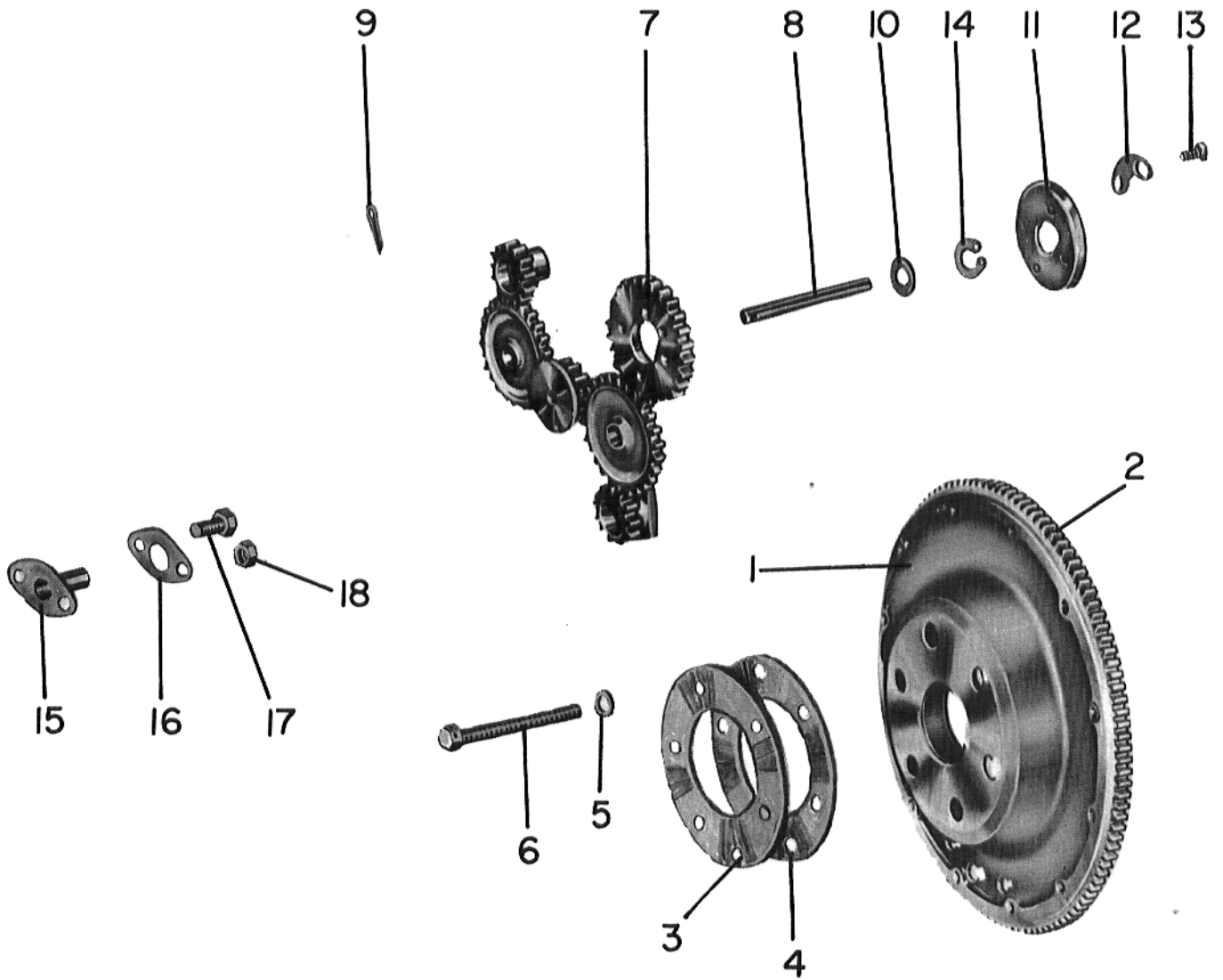

Figure 1-6. Support Assembly and Idler Shafts

SECTION

2

**ACCESSORY
HOUSING AND
RELATED PARTS**

AVCO LYCOMING AIRCRAFT ENGINE GROUP ASSEMBLY PARTS LIST

AVCO LYCOMING PARTS CATALOG
O-320, IO-320 AND LIO-320 SERIES
SECTION 2
ACCESSORY HOUSING AND DRIVES

ACCESSORY HOUSING - SEPARATE CAM GEAR

QUANTITY PER ASSEMBLY

REF.	PART NUMBER	DESCRIPTION	O-320 SERIES																		IO-320			LIO-320			
			A2/A	A2/B	A2/C	A3/A	A3/B	A3/C	B2/A	B2/B	B3/A	B3/B	B3/C	D2A	D2B	D2C	E2A	E2B	E2C	E2D	B7A	B7C	D7A	E7A	E7B	E7C	
1	73818	GASKET, Accessory housing	1	1	1	1	1	1	1	1	1	1	1	1	1	1	1	1	1	1							
1	72498	ACCESSORY HSG., (Plain S4LN-20 and impulse S4LN-21 magnetos)	1	1		1	1			1	1											1	1	1	1		
1	72500	ACCESSORY HSG., (Two impulse S4LN-21 magnetos)	1																								1
1	72501	ACCESSORY HSG., (Plain S4LN-20 and impulse S4LN-21 magneto, vacuum and hyd. dual drive)	1																								
1	72502	ACCESSORY HSG., (Plain S4LN-20 and impulse S4LN-21 magneto, vacuum and prop. gov. dual drive) - STD	1							1				1	1												
1	72502	ACCESSORY HSG., (Plain S4LN-20 and impulse S4LN-21 magnetos, vacuum and prop. gov. dual drive) - WCF	1																								
1	72503	ACCESSORY HSG., (S4LN-200 and S4LN-204 magnetos) - STD				1		1	1																		
1	72504	ACCESSORY HSG., (S4LN-200 and S4LN-204 magnetos)								1																	
1	72506	ACCESSORY HSG., (Plain S4LN-20 and impulse S4LN-21 magnetos)	1																								
1	73972	ACCESSORY HSG., (S4LN-200 and S4LN-204 magneto)											1	1		1	1	1		1					1		
1	74515**	ACCESSORY HSG., (Two impulse S4LN-21 magnetos)													1												1
1	75919*	ACCESSORY HSG., (Two impulse S4LN-21 magnetos)																				1					
ACCESSORY HOUSING PART NUMBER			72498	72500	72501	72502	72503	72504	72506	73972	74515	75919															
ACCESSORY HOUSING RELATED PARTS																											
2	61400	STUD, 1/4-20 x 1.19 in. long	2	2	2	2	2																				
2	75888	STUD, 1/4-20 x 1-1/4 in. long																							2	2	
3	75888	STUD, 1/4-20 x 1-1/4 in. long																							4	4	
4	61238	STUD, 1/4-20 x 2.78 in. long	3	3			3			3	3	3															
4	69740	STUD, 1/4-20 x 3-7/8 in. long																									
5	61238	STUD, 1/4-20 x 2.78 in. long	1	1																							
5	69943	STUD, 1/4-20 x 1-3/8 in. long				1	1			1		1	1	1													
6	61261	STUD, 5/16-18 x 1-1/2 in. long	2	2	2	2	2	2	2	2	2													2	2		
6	67528	STUD, 5/16-18 x 1-5/8 in. long																						2			
7	61261	STUD, 5/16-18 x 1-1/2 in. long	2	2	2	2	2	2	2	2																	
7	61668	STUD, 5/16-18 x 2-3/8 in. long		2																					2	2	
8	61668	STUD, 5/16-18 x 2-3/8 in. long	2	2	2	2																			2	2	
8	61261	STUD, 5/16-18 x 1-1/2 in. long																									
9	61261	STUD, 5/16-18 x 1-1/2 in. long	2	2	2	2	2	2	2	2	2	2	2	2	2	2	2	2	2	2	2	2	2	2	2	2	2
10	61265	STUD, 5/16-18 x 2.19 in. long	3	3	3	3	3	3	3	3	3	3	3	3	3	3	3	3	3	3	3	3	3	3	3	3	3
11	STD-1102	PLUG, 1/8-27 NPT, Allen	2	2	2	2	2	2	2	2	2	2	2	2	2	2	2	2	2	2	2	2	2	2	2	2	2
12	STD-784	PLUG, 3/8-18 NPT, Allen	1	1	1	1	1	1	1	1	1	1	1	1	1	1	1	1	1	1	1	1	1	1	1	1	1
13	STD-1102	PLUG, 1/8-27 NPT, Allen																									1
14	73117	TUBE, Accessory breather	1	1	1	1	1	1	1																	1	1
15	31C-38	STUD, 5/16-18 x 4-3/4 in.																									4
16	68833	SHIELD, Accy. breather, oil	1	1	1	1	1	1	1	1	1	1	1	1	1	1	1	1	1	1	1	1	1	1	1	1	
17	AN456AD4-8	RIVET, .13 x 1/2 in. long	1	1	1	1	1	1	1	1	1	1	1	1	1	1	1	1	1	1	1	1	1	1	1	1	
18	AN456AD4-22	RIVET, .13 x 1-3/8 in. long	1	1	1	1	1	1	1	1	1	1	1	1	1	1	1	1	1	1	1	1	1	1	1	1	
19	STD-1006	RING, Oil seal	1	1	1	1	1	1	1	1	1	1	1	1	1	1	1	1	1	1	1	1	1	1	1	1	
20	75628	PLUG, 5/8 OD x 3/4 in.	1	1	1	1	1	1	1																		
* - AN fuel pump. Long studs at fuel pump pad.																											
** - Accessory housing 74467 is no longer available for IO-320-B1A (STD). Use 74515 housing.																											

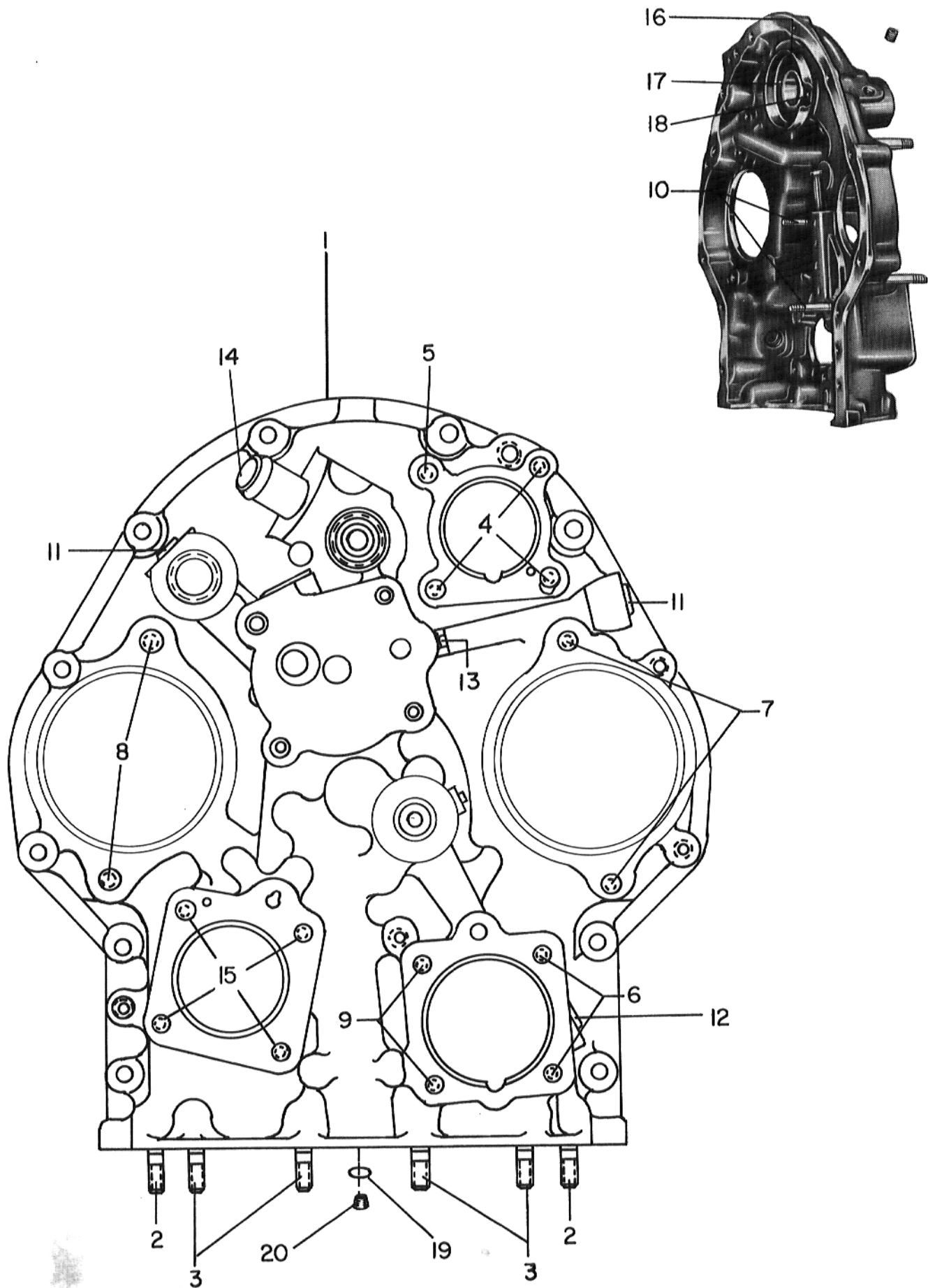

Figure 2-1. Accessory Housing - Separate Cam Gear

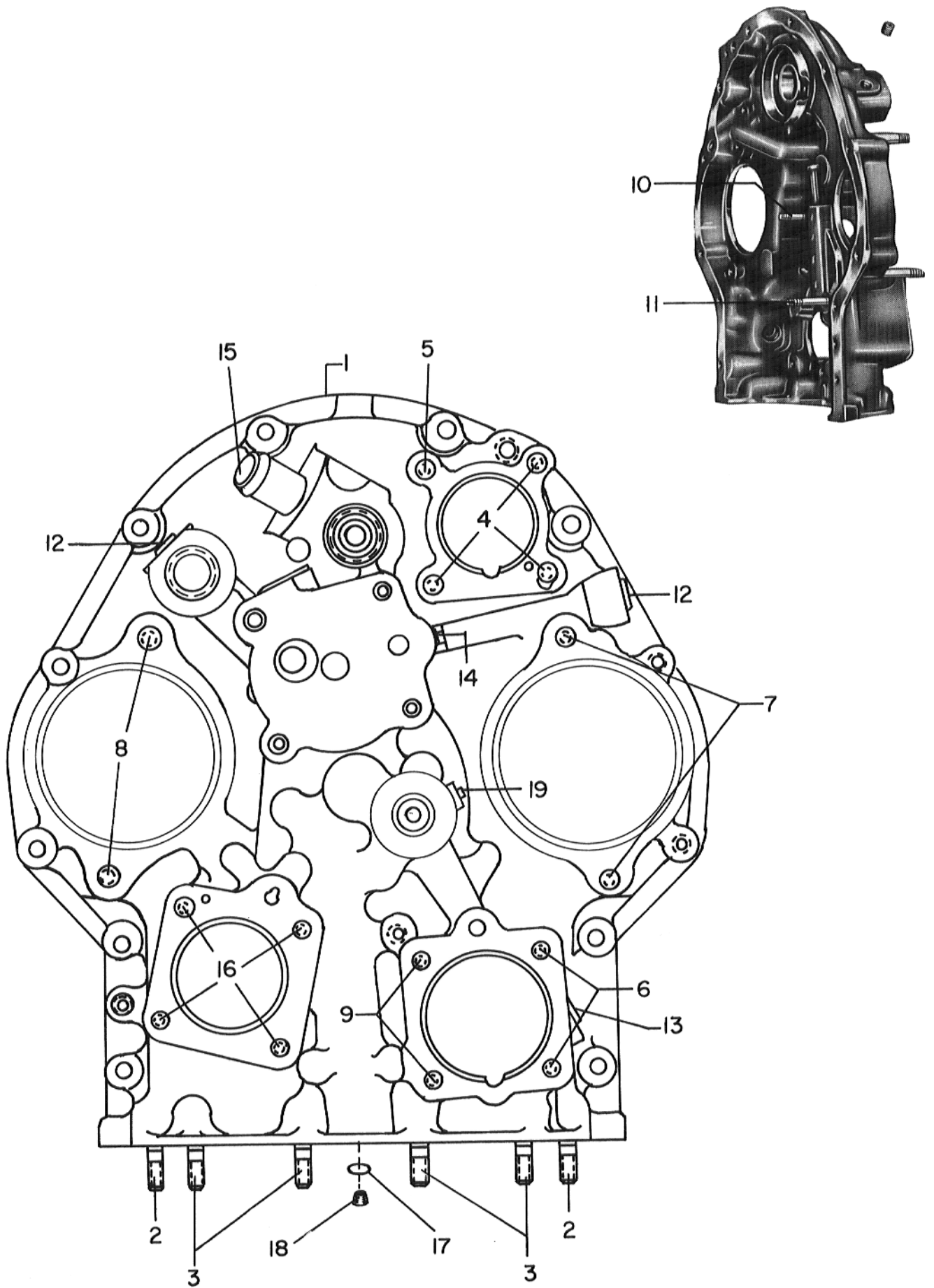

Figure 2-2. Accessory Housing - Integral Cam Gear

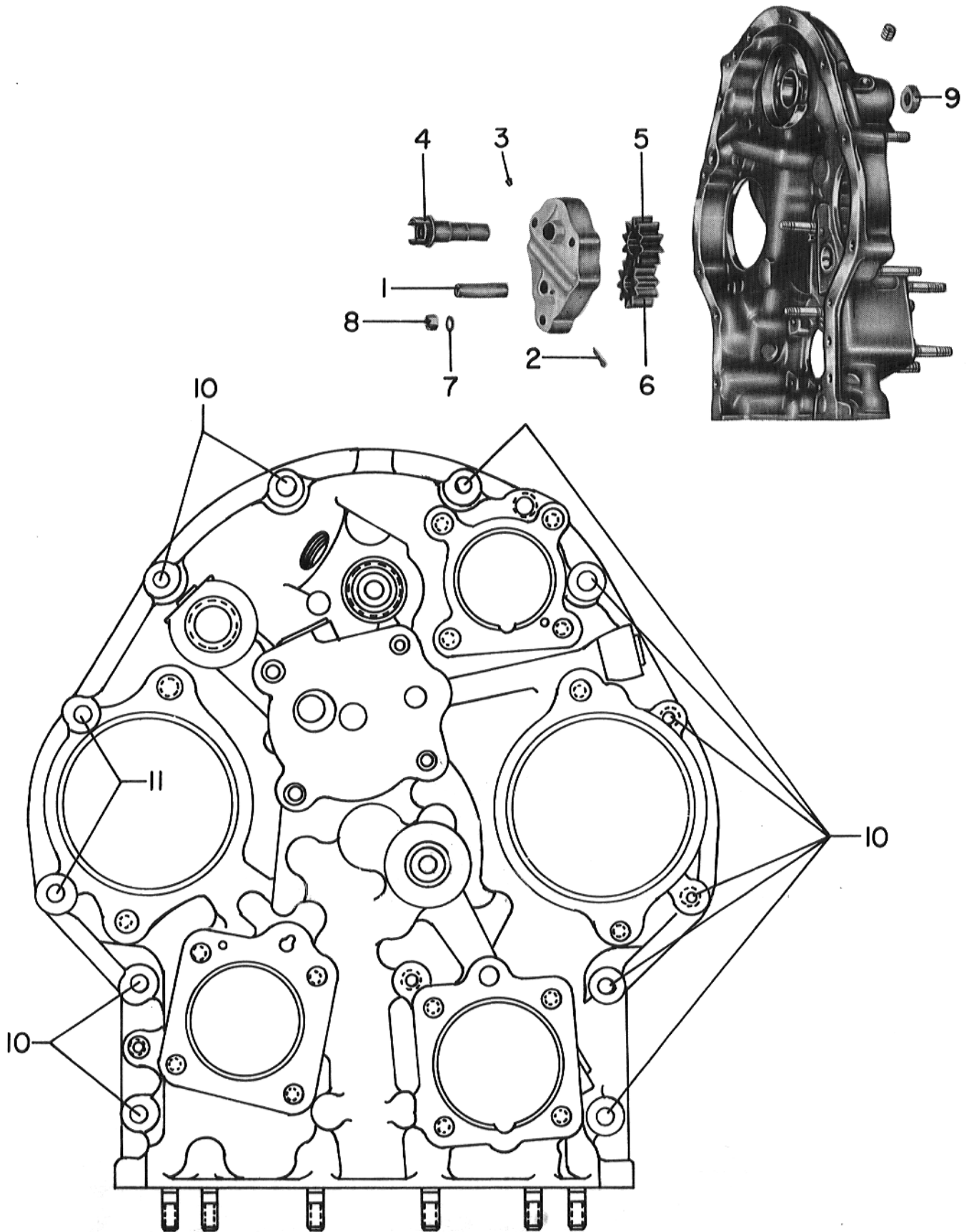

Figure 2-3. Oil Pump and Accessory Housing Attaching Parts

OIL COOLER AND FILTER

SECTION
2
PAGE
2-4

REF.	PART NUMBER	DESCRIPTION	QUANTITY PER ASSEMBLY																										
			O-320 SERIES										IO-320					LIO-320											
			A2A	A2B	A2C	A3A	A3B	A3C	B2A	B2B	B3A	B3B	B3C	D1A	D2A	D2B	D2C	E1A	E2A	E2B	E2D	B1A	B1C	C1A	D1A	E2A	B1A	C1A	
1	68974	HOUSING, Oil pressure screen	1	1	1	1	1	1	1	1	1	1	1	1	1	1	1	1	1	1	1	1	1	1	1	1	1	1	
1	62815*	HOUSING, Oil pressure screen	1	1		1			1	1																			
2	69510	HOUSING, Thermostatic valve and oil pressure screen	1	1	1	1	1	1	1	1	1	1	1	1	1	1	1	1	1	1	1	1	1	1	1	1	1	1	
3	61173	GASKET, Oil pressure housing	1	1	1	1	1	1	1	1	1	1	1	1	1	1	1	1	1	1	1	1	1	1	1	1	1	1	
4	62817	SCREEN ASSY., Oil pressure	1	1	1	1	1	1	1	1	1	1	1	1	1	1	1	1	1	1	1	1	1	1	1	1	1	1	
5	STD-294	GASKET, .88 OD x .63 ID	1	1	1	1	1	1	1	1	1	1	1	1	1	1	1	1	1	1	1	1	1	1	1	1	1	1	
5	STD-294*	GASKET, .88 OD x .63 ID	2	2		2			2	2																			
6	STD-8	WASHER, 1/4 plain	4	4	4	4	4	4	4	4	4	4	4	4	4	4	4	4	4	4	4	4	4	4	4	4	4	4	
6	STD-8**	WASHER, 1/4 plain	3	3		3	3		3	3		3	3		3	3		3	3		3	3		3	3		3	3	
7	STD-1884	SCREW, 1/4-20 x 1.00 in. long	4	4	4	4	4	4	4	4	4	4	4	4	4	4	4	4	4	4	4	4	4	4	4	4	4	4	
7	STD-1884**	SCREW, 1/4-20 x 1.00 in. long	3	3		3	3		3	3		3	3		3	3		3	3		3	3		3	3		3	3	
7	STD-1856	SCREW, 1/4-20 x 1.00 in. (capscrew)																		4								4	
8	75944	VALVE ASSY., Temperature control, oil cooler bypass	1	1	1	1	1	1	1	1	1	1	1	1	1	1	1	1	1	1	1	1	1	1	1	1	1	1	
9	76510	GASKET, Temp. control valve	1	1	1	1	1	1	1	1	1	1	1	1	1	1	1	1	1	1	1	1	1	1	1	1	1	1	
10	75528+	KIT, Oil filter and adapter	1	1	1	1	1	1	1	1	1	1	1	1	1	1	1	1	1	1	1	1	1	1	1	1	1	1	
11	76691	GASKET, Filter and adapter	1	1	1	1	1	1	1	1	1	1	1	1	1	1	1	1	1	1	1	1	1	1	1	1	1	1	
12	6436048	NUT, Nylon	1	1	1	1	1	1	1	1	1	1	1	1	1	1	1	1	1	1	1	1	1	1	1	1	1	1	
13	6436636	GASKET, Rubber	1	1	1	1	1	1	1	1	1	1	1	1	1	1	1	1	1	1	1	1	1	1	1	1	1	1	
14	6436638	GASKET, Rubber	1	1	1	1	1	1	1	1	1	1	1	1	1	1	1	1	1	1	1	1	1	1	1	1	1	1	
15	6435683	FILTER ASSEMBLY	1	1	1	1	1	1	1	1	1	1	1	1	1	1	1	1	1	1	1	1	1	1	1	1	1	1	
16	5579983	GASKET, Copper	1	1	1	1	1	1	1	1	1	1	1	1	1	1	1	1	1	1	1	1	1	1	1	1	1	1	
17	6436624	STUD, Center	1	1	1	1	1	1	1	1	1	1	1	1	1	1	1	1	1	1	1	1	1	1	1	1	1	1	
18	25C10-P03	STUD, 1/4-20 x 1-1/4 in. long	1	1	1	1	1	1	1	1	1	1	1	1	1	1	1	1	1	1	1	1	1	1	1	1	1	1	
19	STD-1411	NUT, 1/4-20 plain	1	1	1	1	1	1	1	1	1	1	1	1	1	1	1	1	1	1	1	1	1	1	1	1	1	1	
20	STD-160	WASHER, 1/4 lock	1	1	1	1	1	1	1	1	1	1	1	1	1	1	1	1	1	1	1	1	1	1	1	1	1	1	
21	STD-8	WASHER, 1/4 plain	4	4	4	4	4	4	4	4	4	4	4	4	4	4	4	4	4	4	4	4	4	4	4	4	4	4	
22	STD-1856	SCREW, 1/4-20, self-locking	3	3	3	3	3	3	3	3	3	3	3	3	3	3	3	3	3	3	3	3	3	3	3	3	3	3	
23	62417¢	PLUG, Oil cooler bypass	1	1	1	1	1	1	1	1				1	1	1	1	1	1	1								1	
24	STD-294¢	GASKET, Oil cooler bypass plug	1	1	1	1	1	1	1	1				1	1	1	1	1	1	1								1	
25	69436¢	SPRING, Oil cooler bypass	1	1	1	1	1	1	1	1				1	1	1	1	1	1	1								1	
26	62415¢	PLUNGER, Oil cooler bypass	1	1	1	1	1	1	1	1				1	1	1	1	1	1	1								1	
27	69675	CONNECTOR, Accessory housing to oil cooler inlet hose	1	1	1	1	1	1	1	1	1	1	1	1	1	1	1	1	1	1	1	1	1	1	1	1	1	1	
28	STD-294	GASKET, .88 OD x .63 ID	1	1	1	1	1	1	1	1	1	1	1	1	1	1	1	1	1	1	1	1	1	1	1	1	1	1	
29	71620	BOLT, Oil cooler fitting												1	1	1	1	1	1	1								1	
30	AN901-8A	GASKET, Metal tube connection seal												1	1	1	1	1	1	1								1	
31	AN777-8D	ELBOW, Universal, 75°												1	1	1	1	1	1	1								1	
32	71623	WASHER, Oil cooler fitting												1	1	1	1	1	1	1								1	
33	AN844-10D	ELBOW, Pipe thread, 5/8 in. ID hose, 45° (Piper)																											1
34	71140	FITTING, Breather, straight (in accessory housing)												1	1	1	1	1	1	1								1	1
34	72413	FITTING, Breather, 120° elbow, (in accessory housing - Beech)												1	1	1	1	1	1	1								1	
		* - Special thermometer connection in oil pressure screen housing.																											
		** - Screws to attach thermostatic valve housing for engines equipped with vacuum and hydraulic pump or vacuum and prop. governor dual drive.																											
		¢ - Not required when thermostatic oil bypass valve is used.																											
		+ - See latest Service Letter No. L157.																											

8 LW-10269 VALVE ASSEMBLY, Temp. control oil cooler by-pass 1

NOTE

Figure reference numbers 10 thru 22 do not apply to IO-320-D1B model engines as shipped from the factory.

For all other parts applicable to IO-320-D1B model engines listed on Page 2-4 use column headed IO-320-D1A.

Figure 2-4. Oil Cooler and Filter

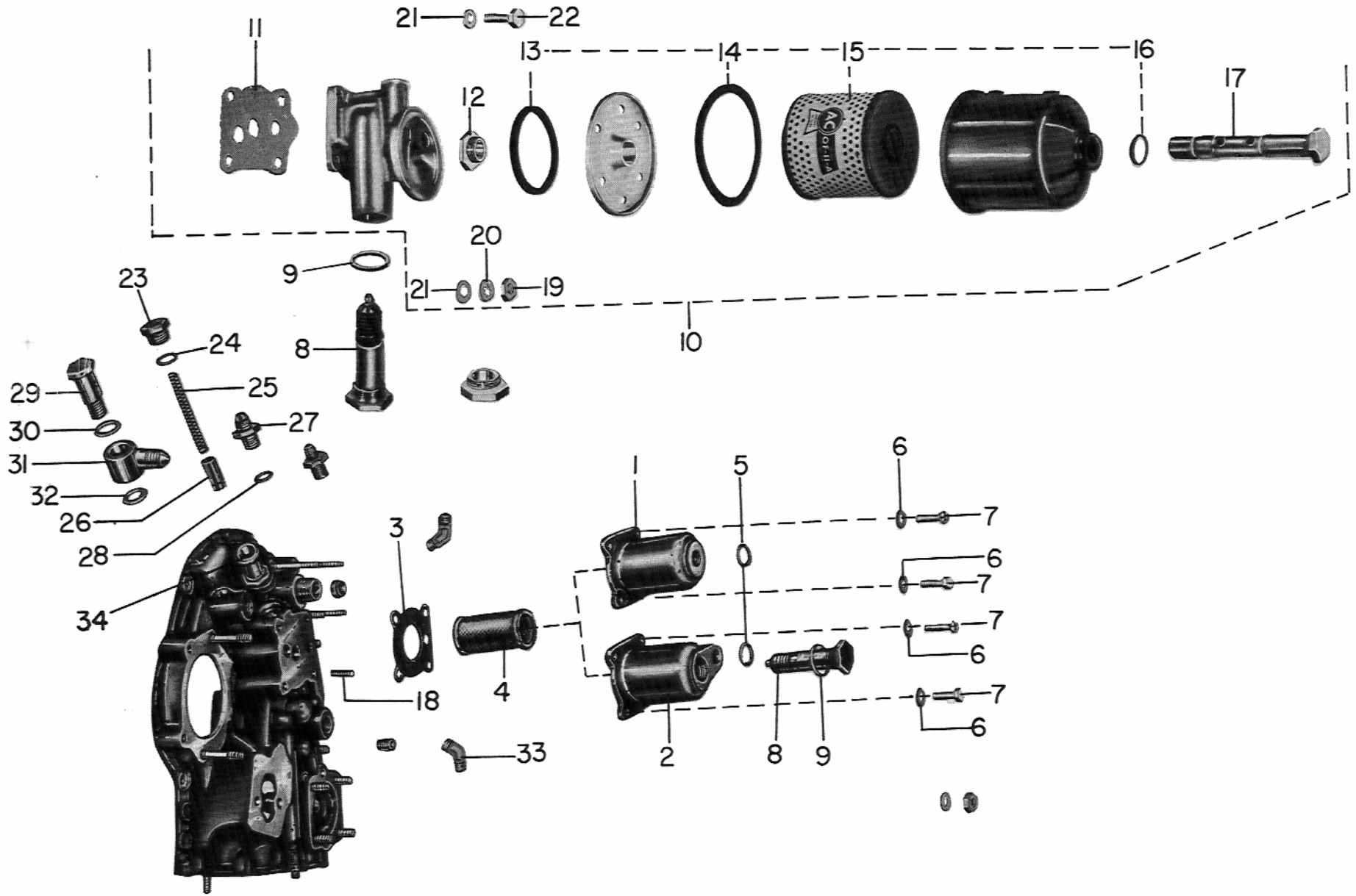
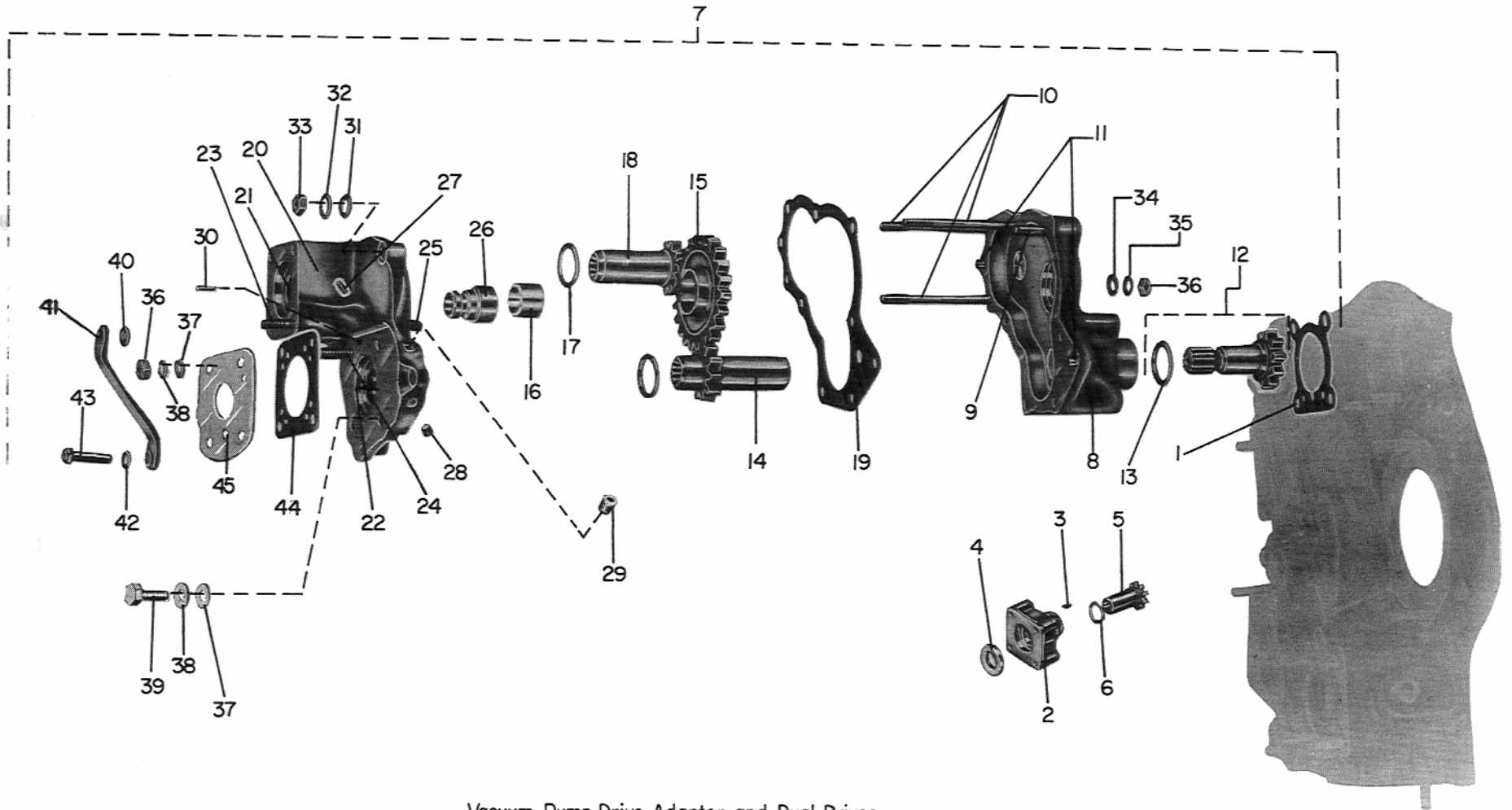

Figure 2-5. Vacuum Pump Drive Adapter and Dual Drives



Vacuum Pump Drive Adapter and Dual Drives

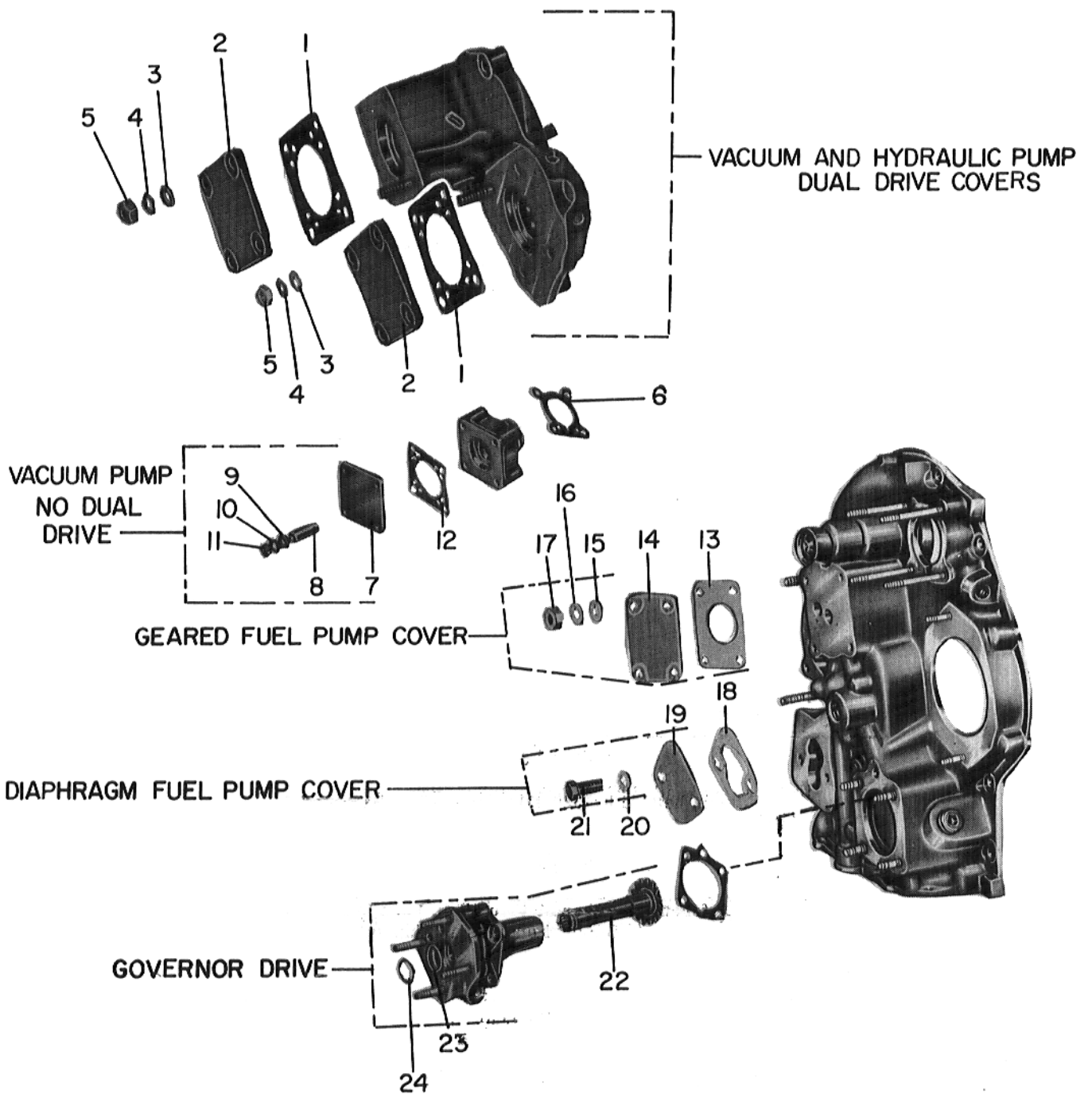

Figure 2-6. Propeller Governor Drive and Covers

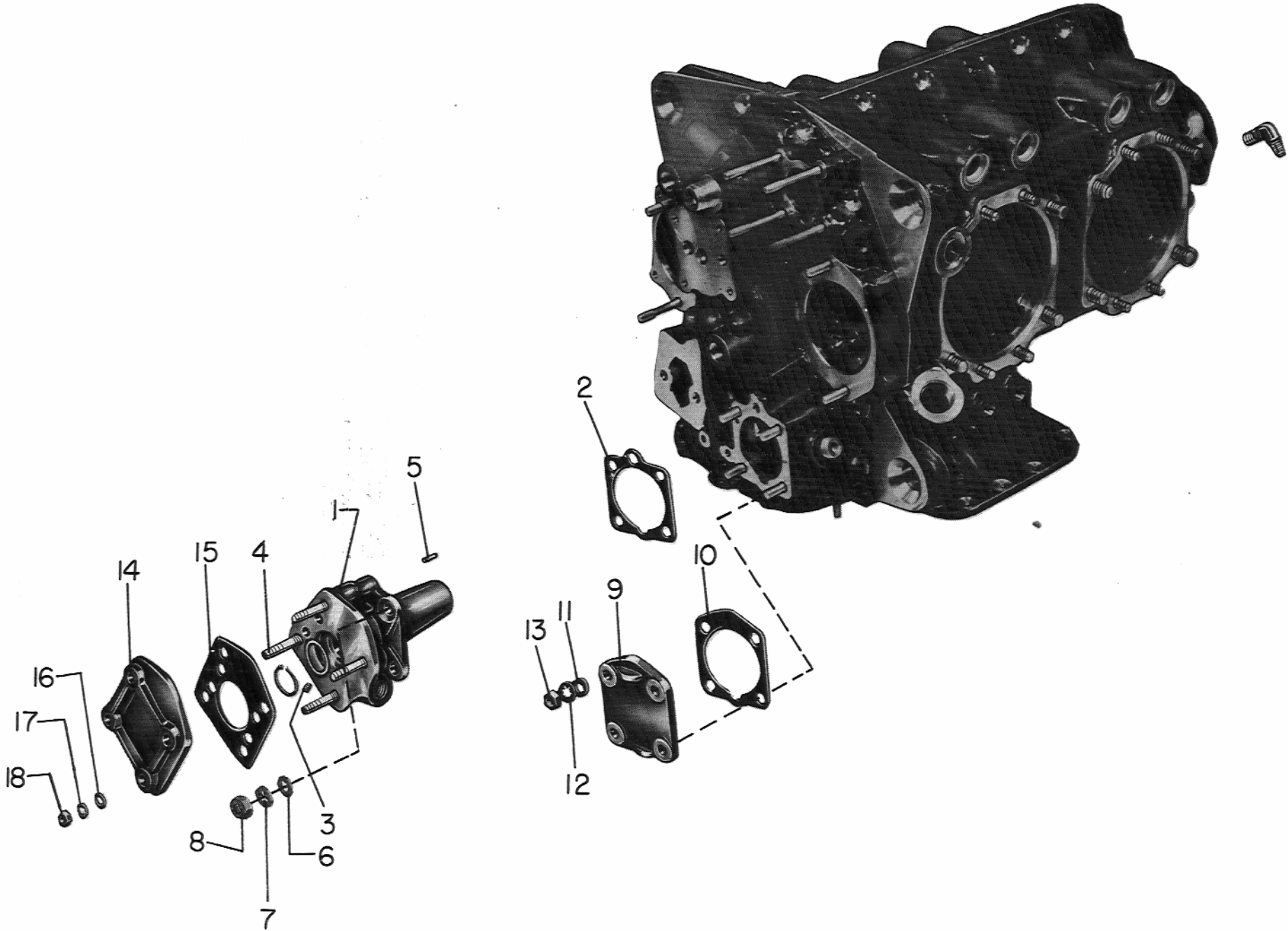

Figure 2-7. Propeller Governor Adapter and Covers

SUMP ASSEMBLY

REF.	PART NUMBER	DESCRIPTION	QUANTITY PER ASSEMBLY																											
			O-320 SERIES										IO-320					LIO-320												
			A2A	A2B	A2C	A3A	A3B	A3C	B2A	B2B	B2C	B3A	B3B	B3C	D1A	D2A	D2B	D2C	E1A	E2A	E2B	E2C	E2D	B1A	B1C	C1A	D1A	E2A	B1A	C1A
1	68972	GASKET, Oil sump	1	1	1	1	1	1	1	1	1	1	1	1	1															1
2	69370*	SUMP ASSEMBLY, Oil - STD	1	1		1				1																				
2	69370**	SUMP ASSEMBLY, Oil - WCF				1																								
2	72362**	SUMP ASSEMBLY, Oil - STD		1	1				1	1		1	1	1	1															
2	72362**	SUMP ASSEMBLY, Oil - WCF		1					1			1			1															1
2	77965+	SUMP ASSEMBLY, Oil - WCF																												1
3	61376	CONNECTION, Intake pipe, front	2	2	2	2	2	2	2	2	2	2	2	2	2															1
4	61377	CONNECTION, Intake pipe, rear	2	2	2	2	2	2	2	2	2	2	2	2	2															2
5	68437	STUD, 5/16-18 x 1-7/8 in. long	4	4	4	4	4	4	4	4	4	4	4	4	4															4
6	STD-551	PLUG, 1/2-14 NPT, square hd.	1	1	1	1	1	1	1	1	1	1	1	1	1															1
7	STD-1204	BOLT, 1/4-20 x 15/16 in. long	6	6	6	6	6	6	6	6	6	6	6	6	6															6
7	STD-8	WASHER, 1/4 plain	6	6	6	6	6	6	6	6	6	6	6	6	6															6
7	STD-160	WASHER, 1/4 lock	6	6	6	6	6	6	6	6	6	6	6	6	6															6
8	STD-1411	NUT, 1/4-20 plain	2	2	2	2	2	2	2	2	2	2	2	2	2															2
8	STD-8	WASHER, 1/4 plain	2	2	2	2	2	2	2	2	2	2	2	2	2															2
8	STD-160	WASHER, 1/4 lock	2	2	2	2	2	2	2	2	2	2	2	2	2															2
9	STD-1204	BOLT, 1/4-20 x 15/16 in. long	12	12	12	12	12	12	12	12	12	12	12	12	12															12
9	STD-8	WASHER, 1/4 plain	24	24	24	24	24	24	24	24	24	24	24	24	24															24
9	STD-160	WASHER, 1/4 lock	12	12	12	12	12	12	12	12	12	12	12	12	12															12
9	STD-1411	NUT, 1/4-20 plain	12	12	12	12	12	12	12	12	12	12	12	12	12															12
10	60820	GASKET, Oil suction tube	1	1	1	1	1	1	1	1	1	1	1	1	1															1
11	61381	TUBE ASSY., Oil suction	1	1	1	1	1	1	1	1	1	1	1	1	1															1
12	STD-1227	WASHER, 1/4 plain, copper	2	2	2	2	2	2	2	2	2	2	2	2	2															2
13	STD-1433	BOLT, 1/4-20 x 1-1/2 in. long	2	2	2	2	2	2	2	2	2	2	2	2	2															2
14	STD-8	WASHER, 1/4 plain (max. 4)	AR	AR	AR	AR	AR	AR	AR	AR	AR	AR	AR	AR	AR															AR
15	STD-1409	NUT, 1/4-20 slotted	2	2	2	2	2	2	2	2	2	2	2	2	2															2
16	STD-68	PIN, 1/16 dia. x 1/2 in. long	2	2	2	2	2	2	2	2	2	2	2	2	2															2
17	61378	SCREEN, Oil suction	1	1	1	1	1	1	1	1	1	1	1	1	1															1
18	STD-1045	GASKET, 1-1/4 ID x 1-1/2 in. OD	1	1	1	1	1	1	1	1	1	1	1	1	1															1
19	61358	PLUG, 1-1/2 in. hex. hd. x 1-1/4-12 thd.	1	1	1	1	1	1	1	1	1	1	1	1	1															1
20	61548	NAMEPLATE	1	1	1	1	1	1	1	1	1	1	1	1	1															1
21	STD-1901	DRIVE STUD, No. 4 x .19 in. long	4	4	4	4	4	4	4	4	4	4	4	4	4															4

* - Large inlet chamfer. Use carburetor 69250.
 ** - Straight riser. Use carburetor 72394, or injector 77260.
 + - Vertical inlet fuel injector. Use injector 77260.

This page does not apply to IO-320-D1B model engines.

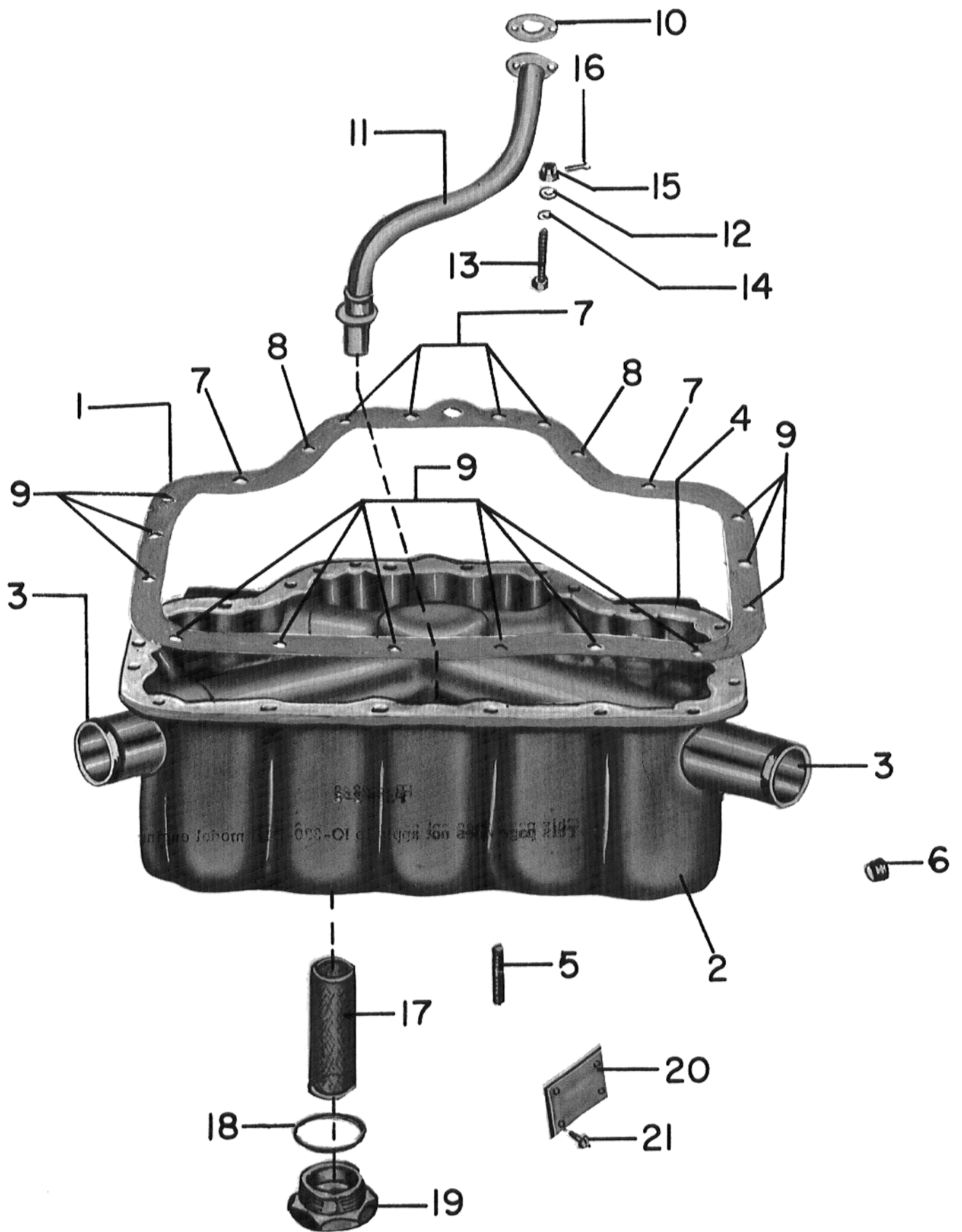

Figure 2-8. Sump Assembly

SUMP ASSEMBLY

SECTION
2
PAGE
2-9

REF.	PART NUMBER	DESCRIPTION	QUANTITY PER ASSEMBLY																									
			O-320 SERIES									IO-320			LIO-320													
			A2A	A2B	A2C	A3A	A3B	A3C	B2A	B2B	B3A	B3B	B3C	D1A	D2A	D2B	D2C	E1A	E1B	E2C	E2D	B7A	B7C	C7A	D7A	E7A	B7A	C7A
1	68972	GASKET, Oil sump																										
2	74083*	SUMP ASSEMBLY, Oil - STD																										
2	74083*	SUMP ASSEMBLY, Oil - WCF																										
2	LW-10751**	SUMP ASSEMBLY, Oil - WCF																										
3	74513+	SUMP ASSEMBLY, Oil -																										
3	76299+	SUMP ASSEMBLY, Oil																										
4	70482	CONNECTION, Intake pipe																										
5	69602	CONNECTION, Intake pipe																										
6	61400	STUD, 1/4-20 x 1-3/16 in. long																										
7	68437	STUD, 5/16-18 x 1-7/8 in. long																										
8	61261	STUD, 5/16-18 x 1-1/2 in. long																										
8	61850	STUD, 5/16-18 x 3.13 in. long																										
9	STD-551	PLUG, 1/2-14 NPT, square head																										
10	STD-91	PLUG, 1/2-14 NPT, Allen																										
11	STD-1102	PLUG, 1/8-27 NPT, Allen																										
12	STD-1204	BOLT, 1/4-20 x 15/16 in. long																										
12	STD-8	WASHER, 1/4 plain																										
12	STD-160	WASHER, 1/4 lock																										
13	STD-8	WASHER, 1/4 plain - STD only																										
14	STD-1411	NUT, 1/4-20 plain																										
14	STD-160	WASHER, 1/4 lock																										
14	STD-8	WASHER, 1/4 plain																										
15	STD-1204	BOLT, 1/4-20 x 15/16 in. long																										
15	STD-8	WASHER, 1/4 plain																										
15	STD-160	WASHER, 1/4 lock																										
15	STD-1411	NUT, 1/4-20 plain																										
16	70484	SCREEN, Oil suction																										
17	STD-111	GASKET, 1.00 ID x 1-1/4 in. OD																										
18	69335	PLUG, 5/8 in. hex. x 1.00-20 thd.																										
19	61548	NAMEPLATE																										
20	STD-1901	DRIVE STUD, No. 4 x .19 long																										

* - Dynafocal mounting. For use with carburetor.
 ** - Dynafocal mounting. For use with injector.
 + - Rear inlet fuel injection.

Page 2-9

2	LW-10830	SUMP ASSEMBLY, Oil	1
4	78914	CONNECTION, Intake pipe	4
12	STD-1204	BOLT, Hex. hd., 1/4-20 x 15/16 in. long	14
	STD-1419	BOLT, Hex. hd., 1/4-20 x 1-1/8 in. long	2

For all other parts listed on Page 2-9, which are applicable to IO-320-D1B model engines, use column headed IO-320-D1A.

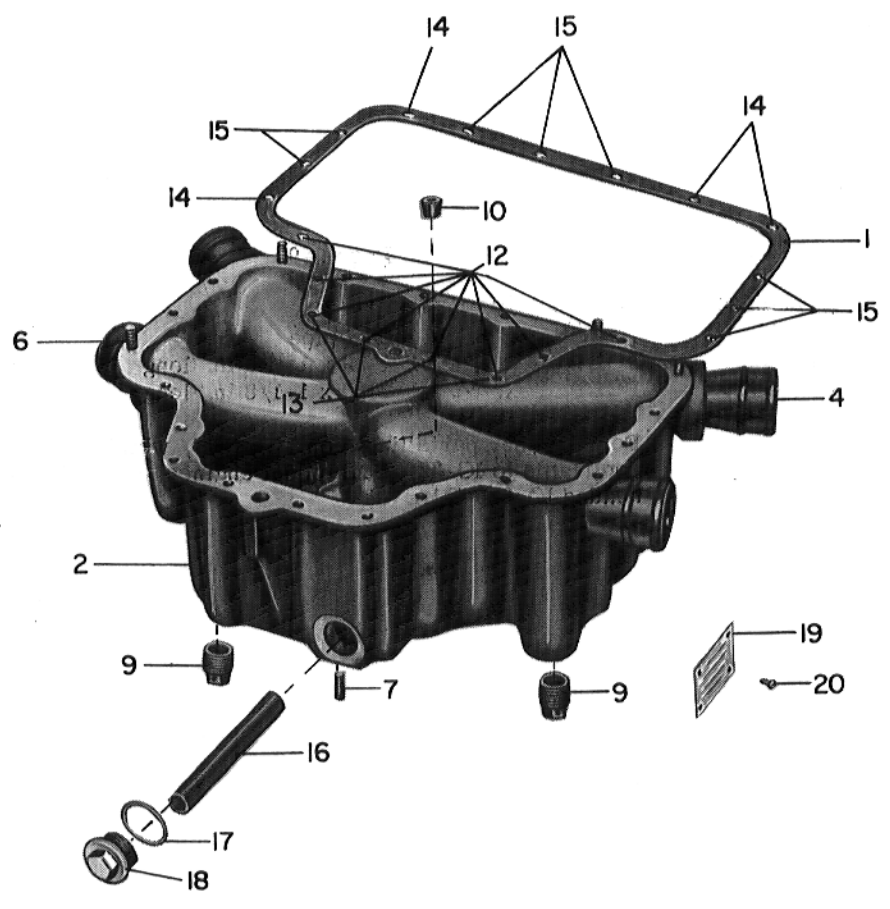
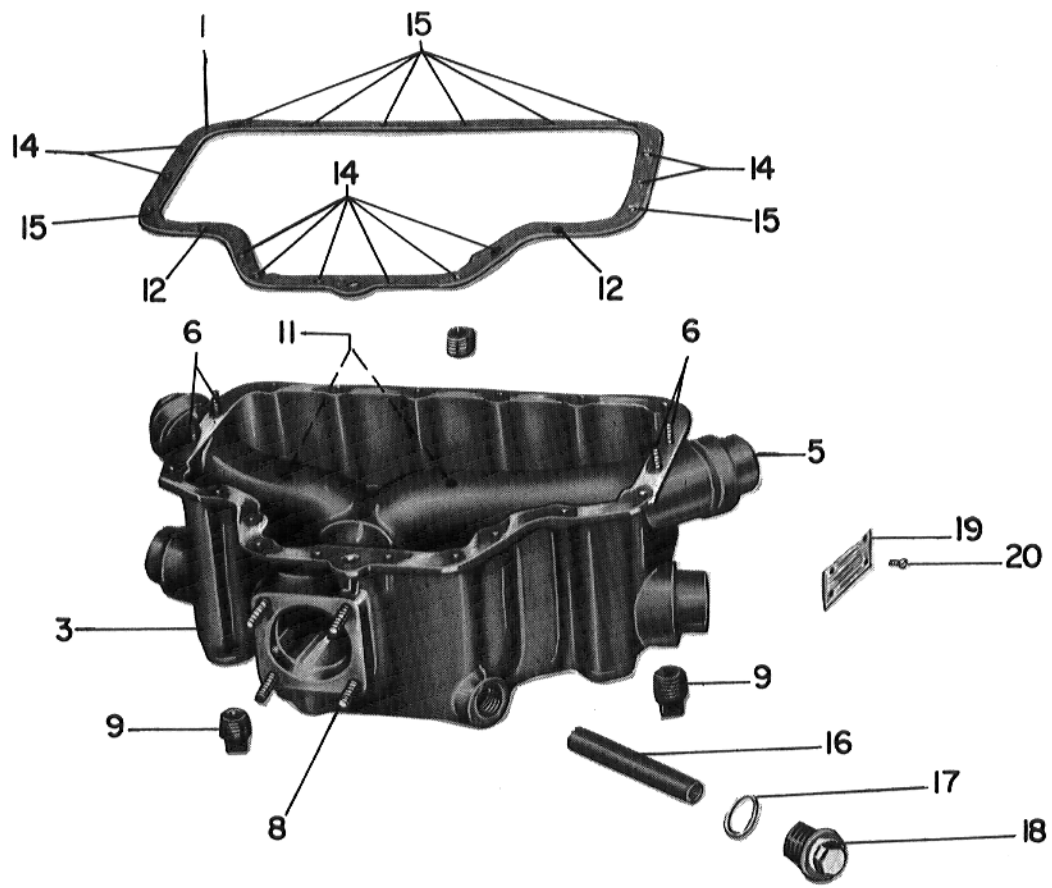

Figure 2-9. Sump Assembly

SECTION

3

**CYLINDER, PISTON
AND VALVE TRAIN**

AVCO LYCOMING PARTS CATALOG
O-320, IO-320 AND LIO-320 SERIES
SECTION 3
CYLINDER, PISTON AND VALVE TRAIN

AVCO LYCOMING AIRCRAFT ENGINE GROUP ASSEMBLY PARTS LIST

with this cylinder	on this model	use this piston	with this top ring	this 2nd ring	this oil ring	this exhaust valve	this intake valve	and service with this kit	
71840C	O-320-A, -E	75413	74673	74673	73998	75068	73938	None	
71840C	O-320-A, -E	74059FW	71556	71556	72454	75068	73938	None	See Note
71841P	O-320-A, -E	75413	74989	74989	73857	75068	73938	None	
71841P	O-320-A, -E	74059FW	68513	68512	72454	75068	73938	None	See Note
71844P	O-320-B, -D	71594FW	68513	68513	69457	74541	73938	None	
71844P	O-320-B, -D	75089	74989	74989	73857	74541	73938	None	
71969C	O-320-B, -D	71594FW	71556	71556	72454	74541	73938	None	
71969C	O-320-B, -D	75089	74673	74673	73998	74541	73938	None	
73149N	O-320-B, -D	75089	74241	74241	73857	74541	73938	None	
74468N	IO-320-B1A	75089	74241	74241	73857	74541	73938	75403	
75042N*	O-320-B, -D and LIO-320-B	75089	74241	74241	73857	74541	73938	75401	
	IO-320-B, -D								
75042N*	O-320-E2A, -E2C	75413	74241	74241	73857	75068	73938	77462	
	IO-320-E2A								
75044N*	O-320-B, -D	75089	74241	74241	73857	74541	73938	None	
75183C	O-320-A, -E	75413	74673	74673	73998	75068	73938	76500	
75183C	O-320-A, -E	74059	71556	71556	72454	75068	73938	None	See Note
75184P	O-320-A, -E	75413	74989	74989	73857	75068	73938	76658	
75184P	O-320-A, -E	74059	68513	68512	72454	75068	73938	None	See Note
75188C	O-320-B, -D	75089	74673	74673	73998	74541	73938	76236	
75188C	O-320-B, -D	71594FW	71556	71556	72454	74541	73938	76234	
75317P*	O-320-A, -E	74059FW	68513	68512	72454	75068	73938	None	
75361N	O-320-B, -D	75089	74241	74241	73857	74541	73938	76235	
75868P*	O-320-A, -E	75413	74989	74989	73857	75068	73938	76659	
75868P*	O-320-A, -E	74059FW	68513	68512	72454	75068	73938	None	See Note
75907C*	O-320-A, -E	75413	74673	74673	73998	75068	73938	78513	
75907C*	O-320-B, -D	75089	74673	74673	73998	74541	73938	76239	
75907C	O-320-A, -E	74059FW	71556	71556	72454	75068	73938	None	See Note
76086N*	IO-320-C1A and LIO-320-C1A	75089	74241	74241	73857	76081	73938	76449	
77476P	O-320-B, -D	75089	74989	74989	73857	74541	73938	78515	
77476P	O-320-B, -D	71594FW	68513	68513	69457	74541	73938	78516	
75854C*	O-320-A2B	75413	74673	74673	73998	75068	73938	None	

* - Wide Cylinder Flange.

C - Chrome

P - Plain

N - Nitrided

FW - Full Wedge Rings

NOTE: Piston P/N 74059 and P/N 75413 are interchangeable singly or in sets - with proper ring combination. Piston 74059 is no longer available. Pistons and rings are available in oversize P10 and P20, for use in plain cylinder barrels only.

See latest edition of Service Instruction No. 1037

7/16" exhaust valves are no longer available. See latest edition of Service Instruction No. 1136.

SECTION 3

CYLINDER, PISTON AND VALVE TRAIN

Page 3-1

Use all columns opposite first listing of cylinder assembly, P/N 75042-N for IO-320-D1B model engines. On illustration page use light piston pin, P/N 6965Q and P/N 60828 piston pin plug for IO-320-D1B model engines.

AVCO LYCOMING AIRCRAFT ENGINE GROUP ASSEMBLY PARTS LIST

O-320, IO-320, LIO-320 SERIES
3-1 - PISTON AND RINGS

REF. NO.	PART NUMBER	DESCRIPTION					QTY. PER ENG.	MODEL USAGE
		1	2	3	4	5		
1	See chart						4	See chart opposite for model application.
2	opposite for						4	
3	part						4	
4	numbers						4	
5*	77857						4	
5	69650						4	
6	60828						8	
6	72198						8	

* - O-320-A and -E (low compression) only.



Figure 3-1. Piston and Rings

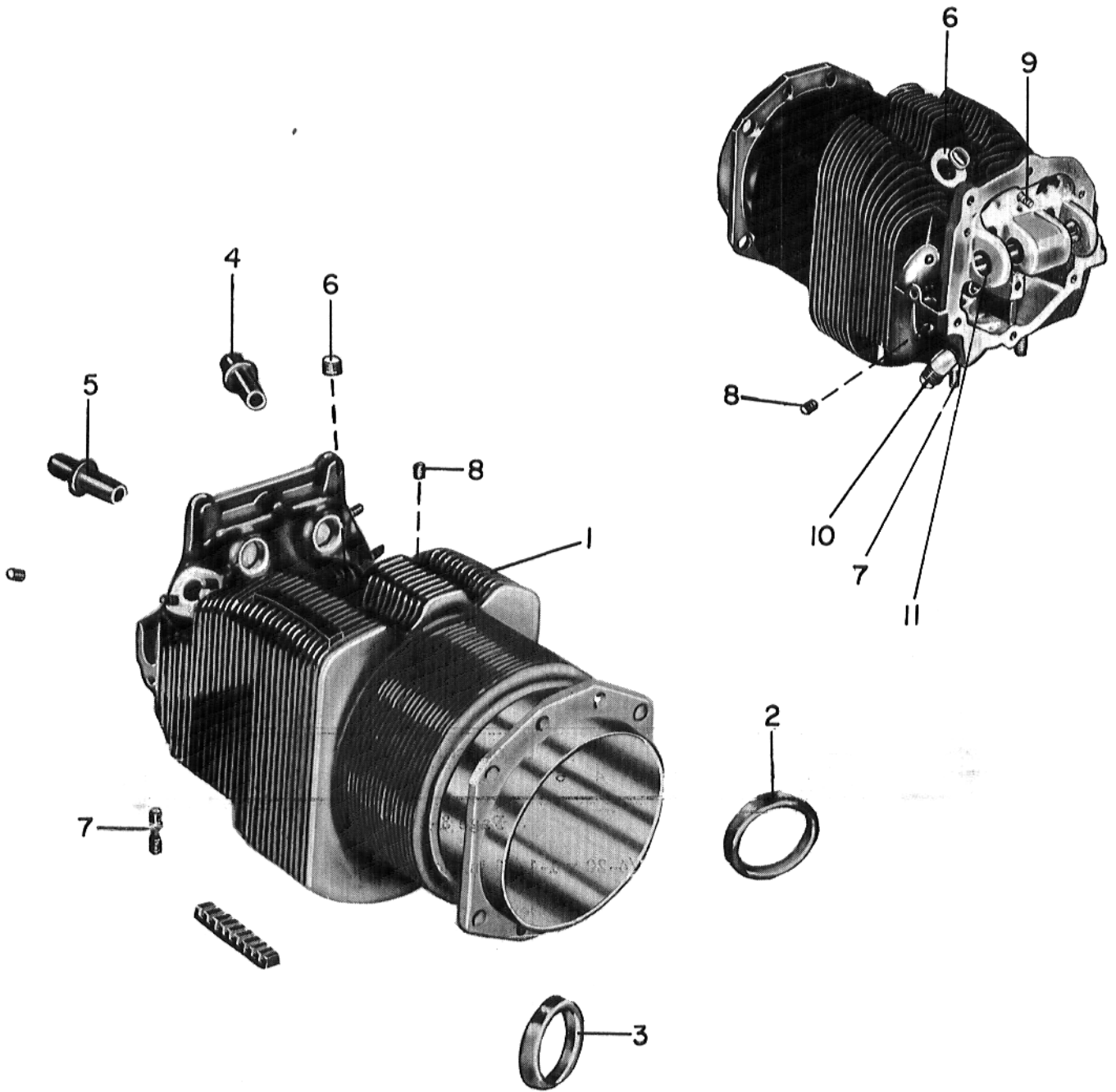
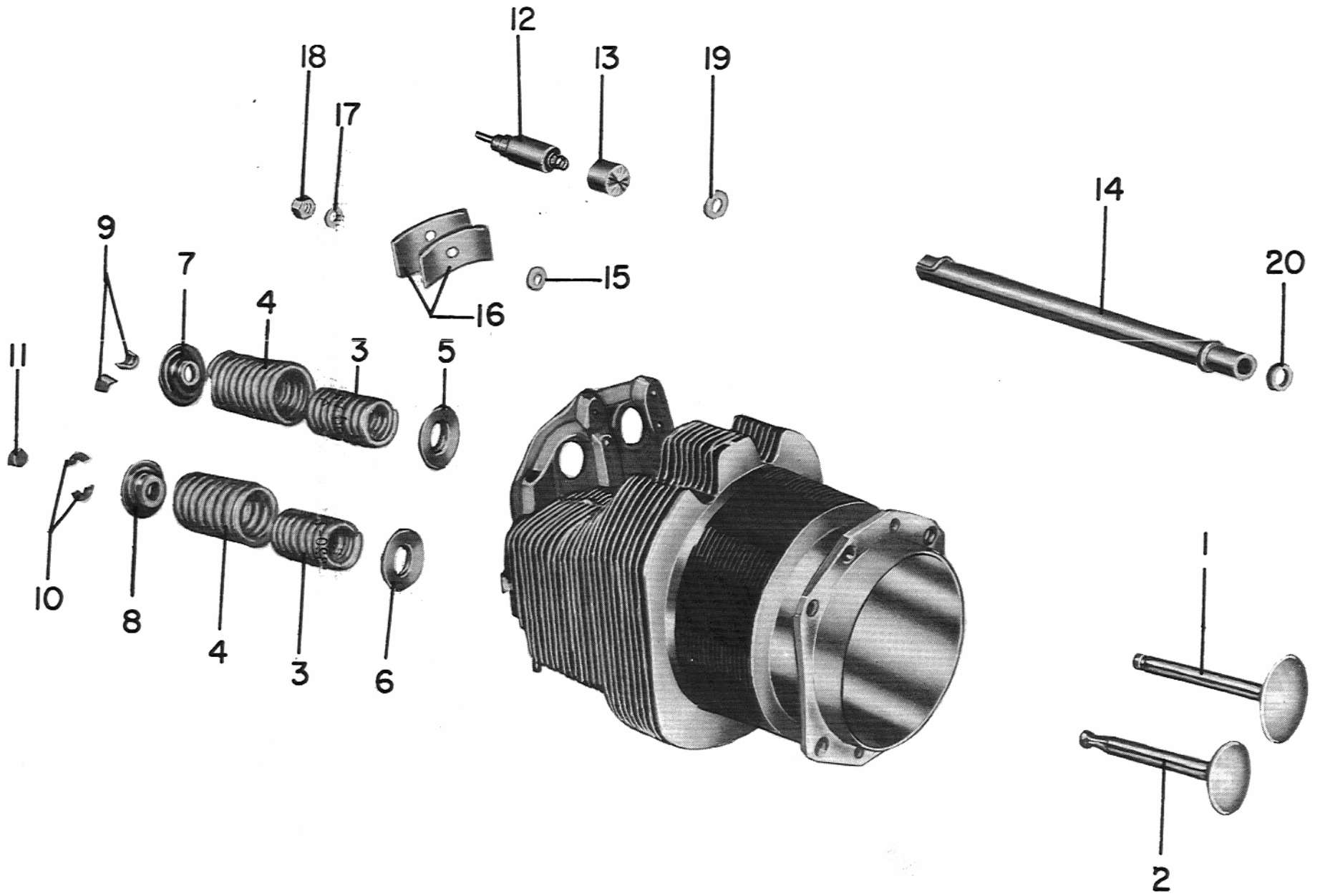

Figure 3-2. Cylinder Assembly

Figure 3-3. Valves and Plungers



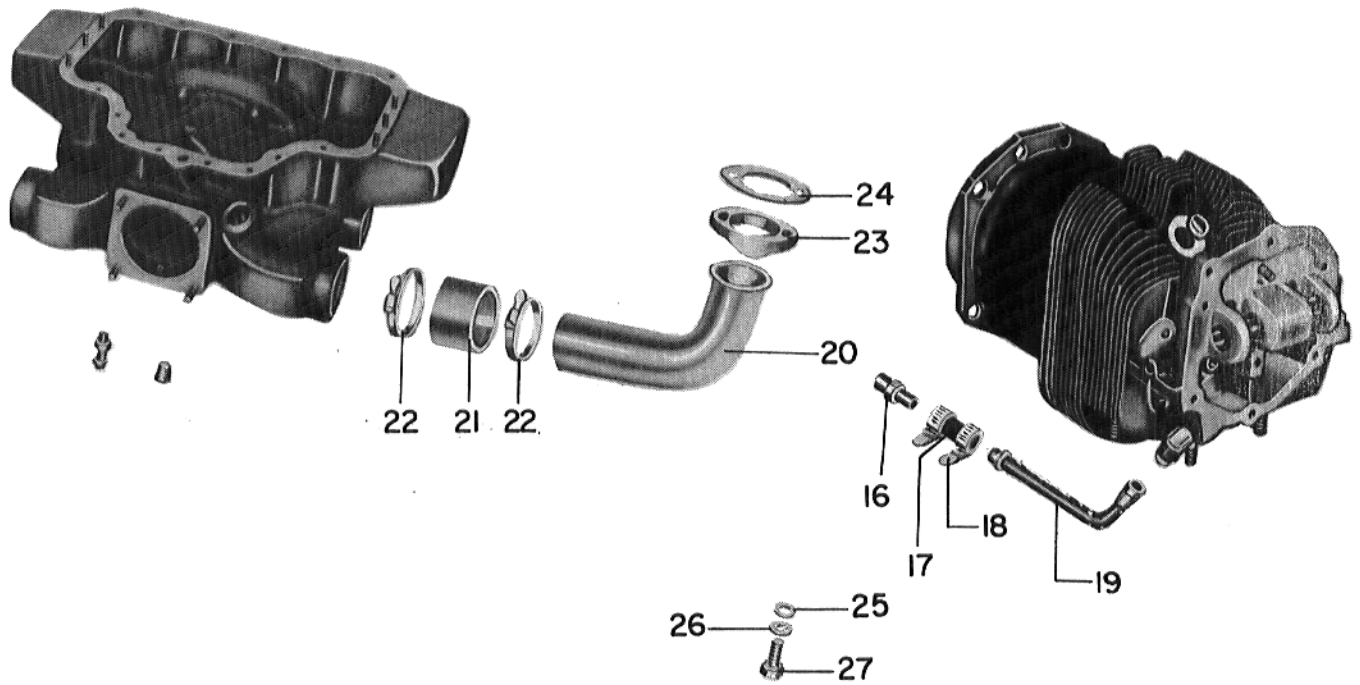
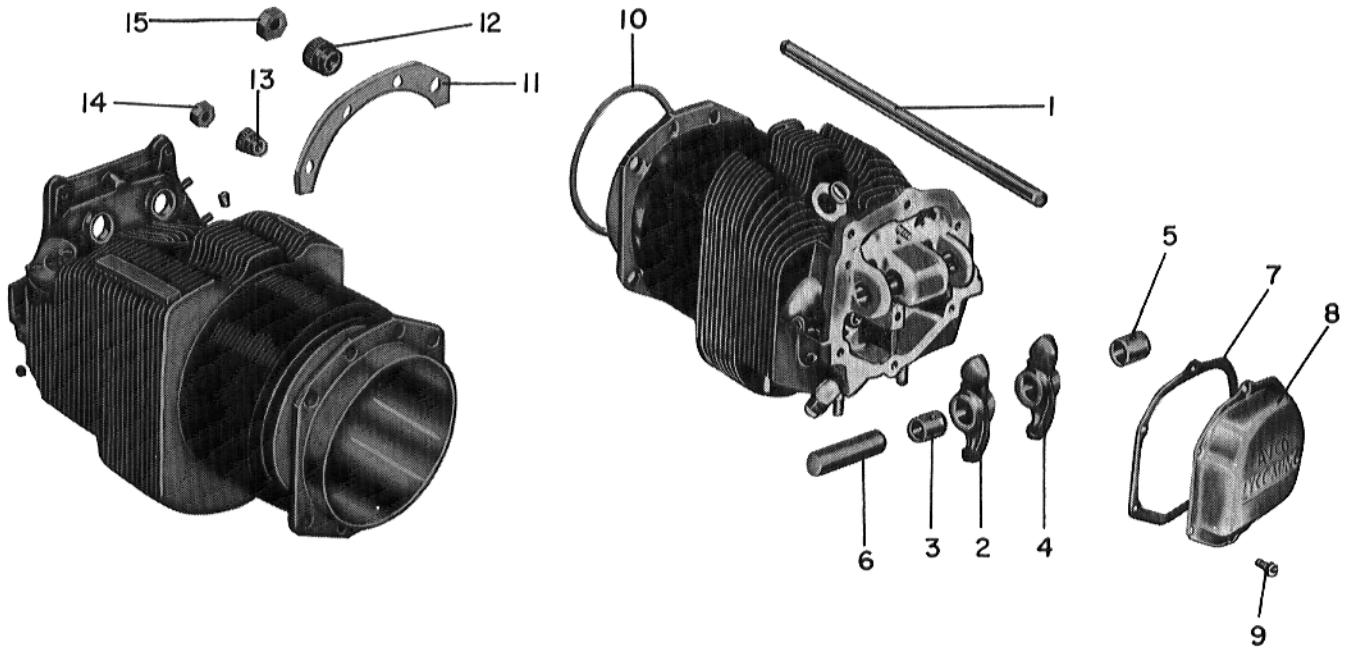

Figure 3-4. Rockers, Push Rods, Intake Pipes and Oil Drain Tubes

SECTION

4

IGNITION SYSTEM

AVCO LYCOMING PARTS CATALOG

O-320, IO-320 AND LIO-320 SERIES

SECTION 4

IGNITION SYSTEM

SECTION 4

IGNITION SYSTEM

Page 4-1

1	75896	MAGNETO, S4LN-1209	1
	75897	MAGNETO, S4LN-1227, Impulse coupling	1

For all magneto related parts use column headed
P/N 75897 for IO-320-D1B model engines.

MAGNETOS

SECTION
4
PAGE
4-1

REF.	PART NUMBER	DESCRIPTION	QUANTITY PER ASSEMBLY																																
			O-320 SERIES							10-320					L10-320																				
			A2A	A2B	A2C	A3A	A3B	A3C	B2A	B2B	B3A	B3B	B3C	D2A	D2B	D2C	E2A	E2B	E2C	E2D	B7A	B7C	C7A	D7A	E7A	B7A	C7A								
1	71398	MAGNETO, S4LN-20	1	1																															
1	71397	MAGNETO, Impulse coupling, S4LN-21	1	1		1	1		1	1	1	1	1								1*	1				1									
1	71397	MAGNETO, Impulse coupling, S4LN-21	2																			2		2			1								
1	71432	MAGNETO, Impulse coupling, S4LN-21	2																																
1	72524	MAGNETO, S4LN-204 - STD				1		1	1				1			1																			
1	73360	MAGNETO, S4LN-200, retard breaker - STD					1	1	1				1			1																			
1	72524	MAGNETO, S4LN-204 - WCF											1						1																
1	73360	MAGNETO, S4LN-200, retard breaker - WCF											1						1																
1	75896	MAGNETO, S4LN-1209																	1							1									
1	75897	MAGNETO, Impulse coupling, S4LN-1227																	1								1								
1	72524	MAGNETO, S4LN-21 - WCF																	1																
1	77985	MAGNETO, Impulse coupling, S4LN-21, with feed thru capacitor - WCF																	1																
1	71397	MAGNETO, Impulse coupling, S4LN-21																	1																
1	LW-11145	MAGNETO, Impulse coupling, S4LN-21, ft. magneto with elec. tach. breaker																								1									
1	71397	MAGNETO, Impulse coupling, S4LN-21																								1									
1	78955	MAGNETO, S4LN-21, with elec. tach. pick-up																								1									
1	LW-10518	MAGNETO, Impulse coupling, S4RN-21																									2								
	77742	MAGNETO AND HARNESS ASSY., Rt.																									2								
1	76949	MAGNETO, Rt. (Slick model 4050)																									1								
	77744	MAGNETO AND HARNESS ASSY., Left																									1								
1	76950	MAGNETO, Left (Slick model 4051)																									1								
MAGNETO PART NUMBER			71398	71397	71432	72524	73360	75896	75897	72524	77985	71397	LW-11145	71397	78955	LW-10518	76949	76950																	
MAGNETO RELATED PARTS																																			
2	61665	GEAR, Magneto impulse coupling	1	2	2					1	1	2	1	2	1																				
2	61163	GEAR, Magneto	1	1		1	1	1				1																							
2	72495	GEAR, Magneto, (retard breaker)				1																													
3	62224	GASKET, Magneto or adapter	3	4	4	2	1	3	4	3	4	1																							
3	78292	GASKET, Magneto					2					2																							
4	61666	ADAPTER, Magneto	1	2	2		1	1	1	1	2	1																							
5	75965	CLAMP, Magneto						4																											
	76961	CLAMP, Magneto																									4								
6	STD-1727	WASHER, Plain, 3/4 in. OD x 21/64 ID x .13	4	4	4	4			4	4	4	4	4	4	4	4	4	4									4								
7	STD-475	WASHER, 5/16 lock	4	4	4	4	4	4	4	4	4	4	4	4	4	4	4	4									4								
8	STD-1410	NUT, 5/16-18 plain	4	4	4	4	4	4	4	4	4	4	4	4	4	4	4	4									4								
	61566	KIT ASSY., Magneto ground	2	2	2					1	2	1																							
	71574	KIT, Magneto ground				2				1		1																							
	71571	KIT, Magneto retard				1																													

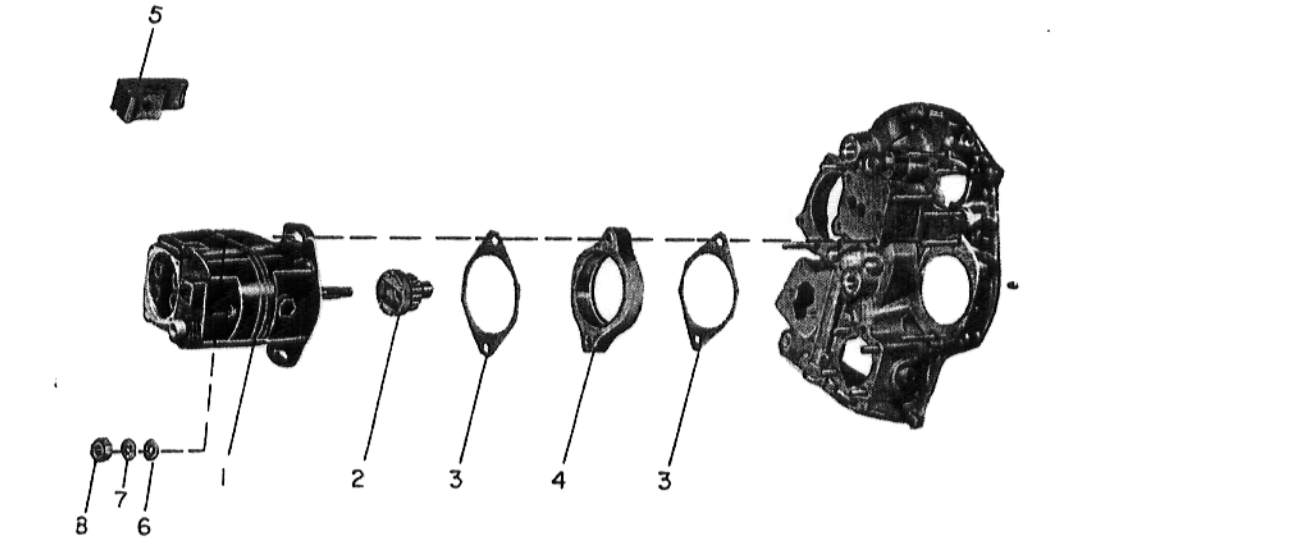

Figure 4-1. Magnetos

UNSHIELDED IGNITION HARNESS

SECTION
4
PAGE
4-2

REF.	PART NUMBER	DESCRIPTION	QUANTITY PER ASSEMBLY																										
			O-320 SERIES								IO-320				L10-320														
			A2A	A2B	A2C	A3A	A3B	A3C	B2A	B2B	B3A	B3B	B3C	D1A	D2A	D2B	D2C	E1A	E2A	E2B	E2C	E2D	B1A	B1C	C1A	D1A	E1A	B1A	C1A
	73729	CABLE AND PLATE ASSY., Ignition, unshielded - STD	1	1			1				1	1																	
	73729	CABLE AND PLATE ASSY., Ignition, unshielded - WCF		1																									
1	45664	CABLE, Spark plug	AR	AR			AR	AR	AR	AR																			
2	73726	LOCKCLIP	8	8			8				8	8																	
3	73245	EYELET	8	8			8				8	8																	
4	61546	SLEEVE	12	12			12				12	12																	
5	STD-957	GROMMET, . 27 ID	4	4			4				4	4																	
6	60670	PLATE, Spark plug cable	2	2			2				2	2																	
7	73246	KIT ASSY., Ignition cable	2	2			2				2	2																	
8	61561	PLATE, Ignition cable outlet	2	2			2				2	2																	
9	61559	GROMMET, Ignition cable	2	2			2				2	2																	
10	73245	EYELET	8	8			8				8	8																	
11	72351	SCREW, No. 10-32	8	8			8				8	8																	
12	71913	CLAMP, 1-1/2 ID with . 34 dia. offset	4	4			4				4	4																	
13	STD-553	SCREW, No. 6-32 x 1/2 in. long	4	4			4				4	4																	
14	AN365-632C	NUT, No. 6-32, self-locking	4	4			4				4	4																	
15	61385	CLIP, Ignition cable	2	2			2				2	2																	
16	STD-8	WASHER, 1/4 plain	2	2			2				2	2																	
17	STD-160	WASHER, 1/4 lock	2	2			2				2	2																	
18	AN500-416-12	SCREW, 1/4-20 x 3/4 in. long - STD	2	2			2				2	2																	
18	AN500-416-18	SCREW, 1/4-20 x 1.13 in. long		2																									
19	STD-1411	NUT, 1/4-20 plain	2	2			2				2	2																	
	40239	PROTECTOR, Ignition cable (top leads)	4	4			4				4	4																	

Page 4-2

This page does not apply to IO-320-D1B model engines.

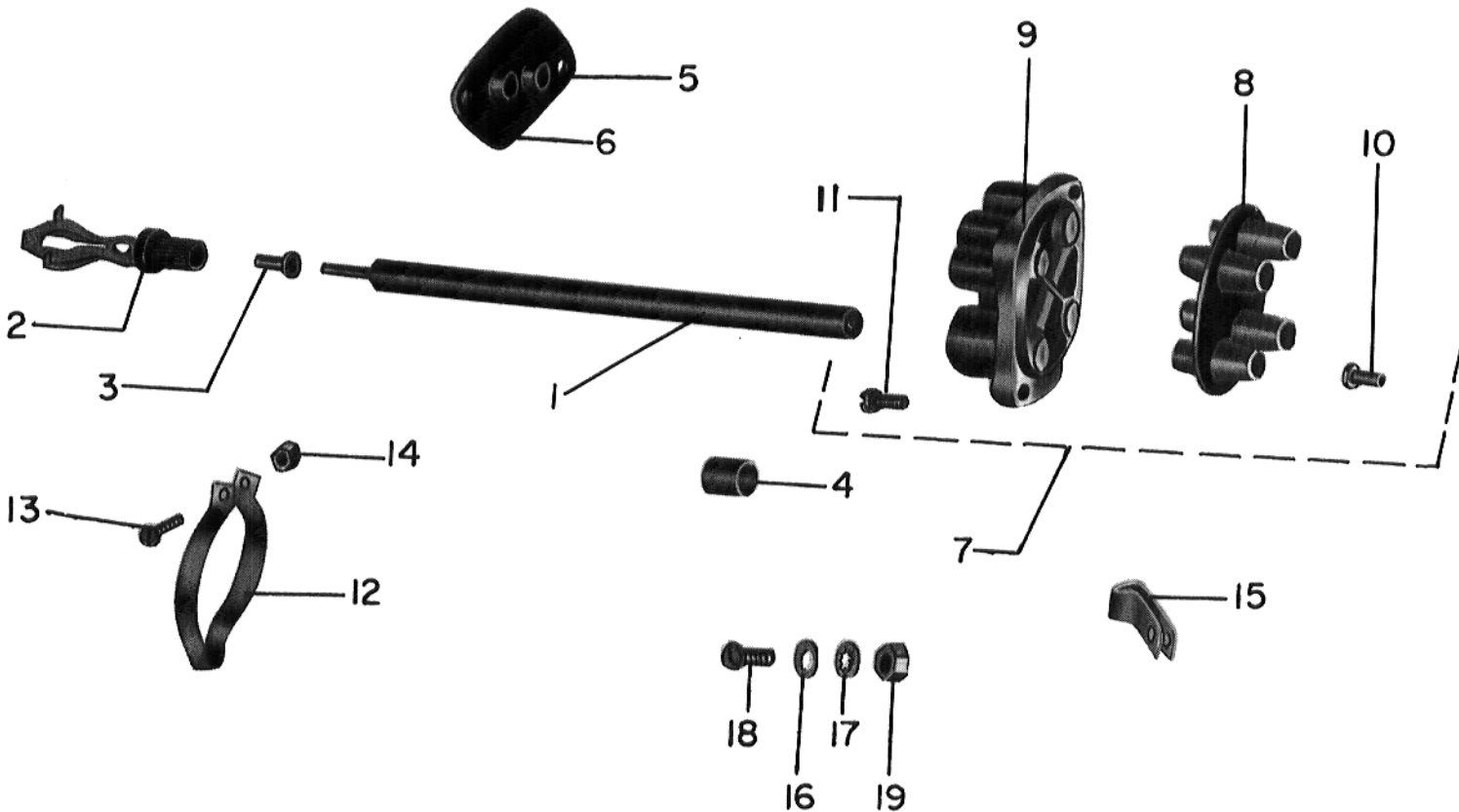

Figure 4-2. Unshielded Ignition Harness

REF. NO.	PART NUMBER	1	2	3	4	5	DESCRIPTION	QTY. PER ENG.
-------------	----------------	---	---	---	---	---	-------------	---------------------

Page 4-3

78546	IGNITION HARNESS, 1200 series mags., straight valve head							1
-------	--	--	--	--	--	--	--	---

For related ignition harness parts use column headed IO-320-D1A for IO-320-D1B model engines.

NOTE

Following is a complete listing of harness attaching parts, which differs somewhat from basic catalog.

76734	ZIP STRAPS							6
68604	CLAMP, Rubber dip, 1-wire							2
71824	CLAMP, Rubber dip, 2-wire							2
73050	CLAMP, Rubber dip, 4-wire							1
STD-8	WASHER, Plain, 1/4 in.							8
40239	PROTECTOR, Ignition cable (top leads)							4
STD-160	WASHER, Internal lock, 1/4 in.							4
AN500-416-12	SCREW, 1/4-20 x 3/4 in. long							4
STD-696	WASHER, Plain, 1/4 in., thin							AR

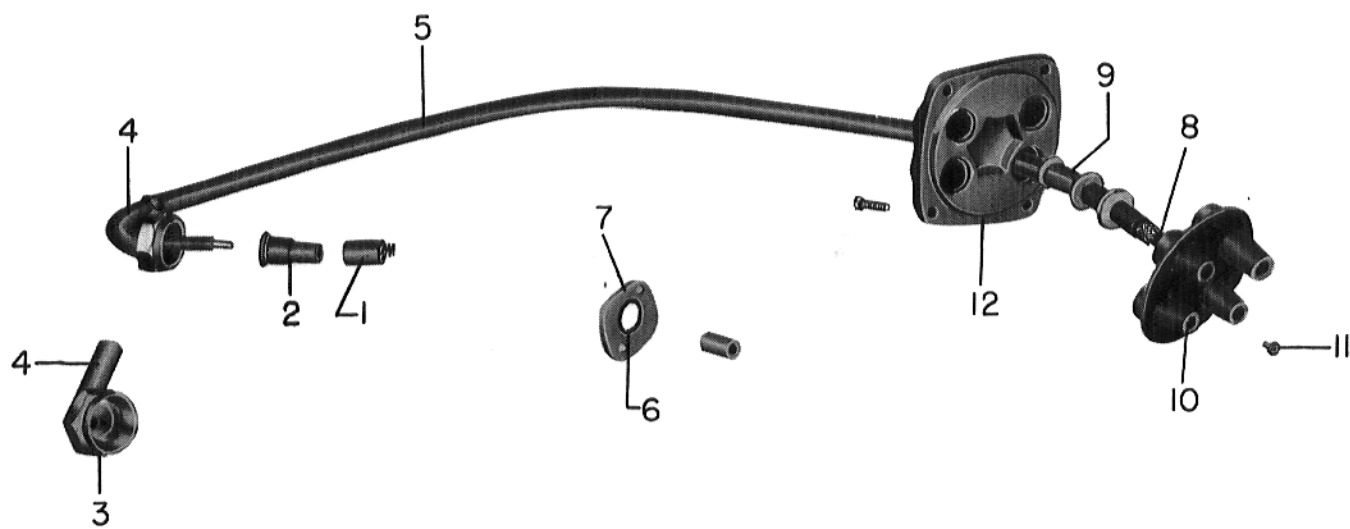

Figure 4-3. Shielded Ignition Cable - Avco Lycoming 5MM

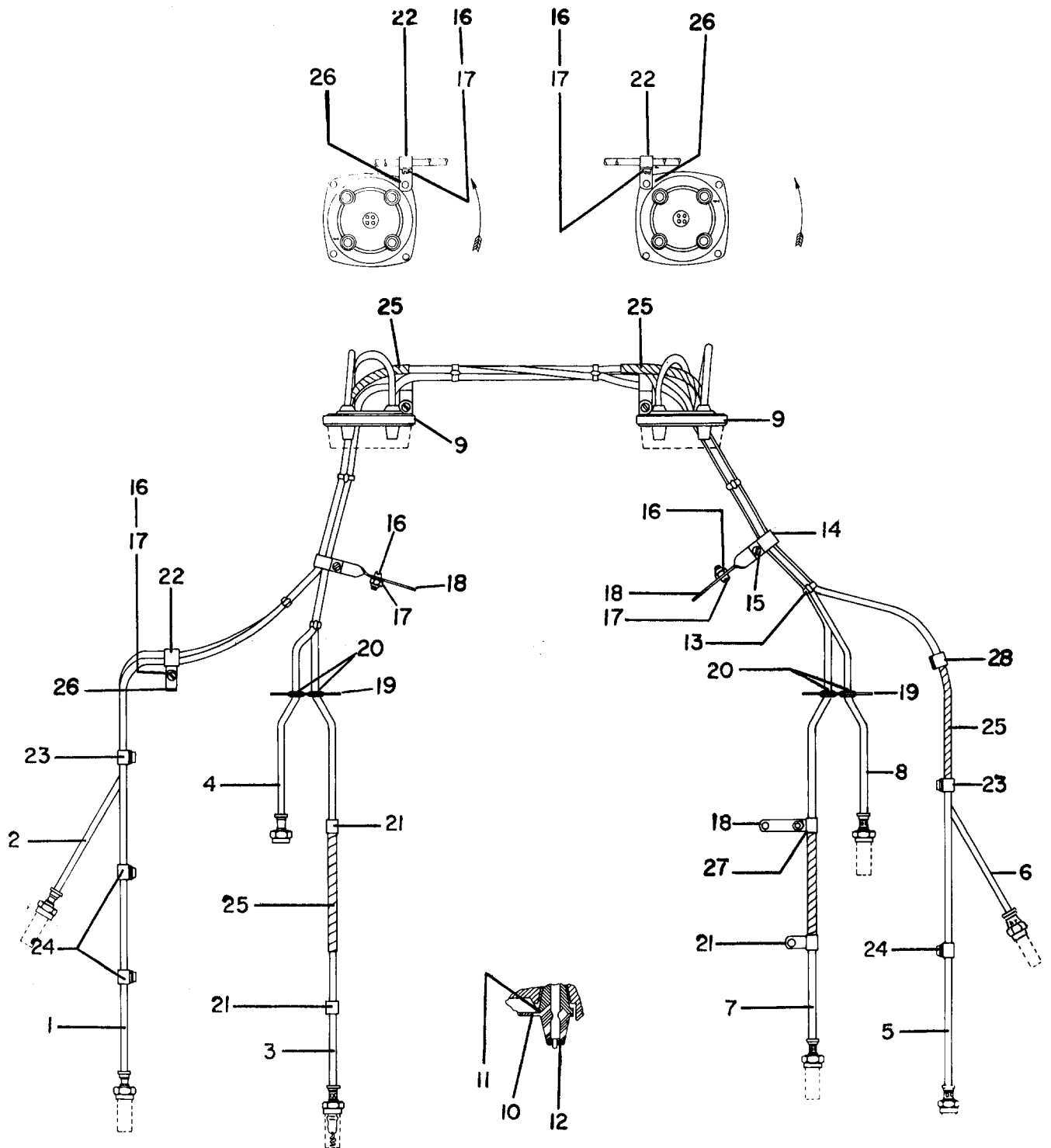

Figure 4-4. Harness Assembly, Scintilla - 1200 Series Magneto

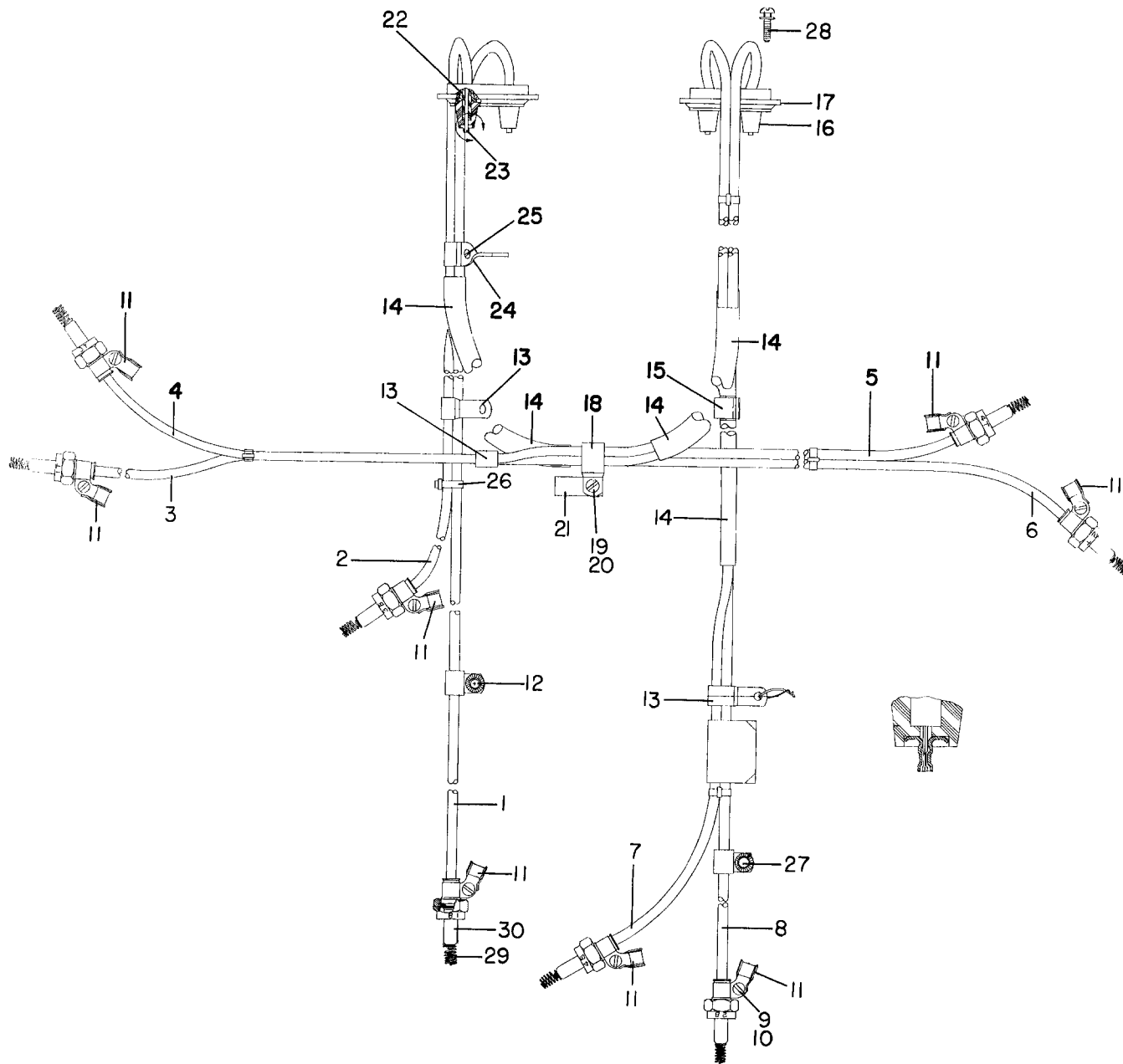

Figure 4-5. Harness Assembly, Scintilla -200 Series Magneto

SECTION

5

ELECTRICAL SYSTEM

AVCO LYCOMING AIRCRAFT ENGINE GROUP ASSEMBLY PARTS LIST

AVCO LYCOMING PARTS CATALOG

O-320, IO-320 AND LIO-320 SERIES

SECTION 5

ELECTRICAL SYSTEM



Figure 5-1. Generator/Alternator Bracket - Std. Cylinder Flange Engines

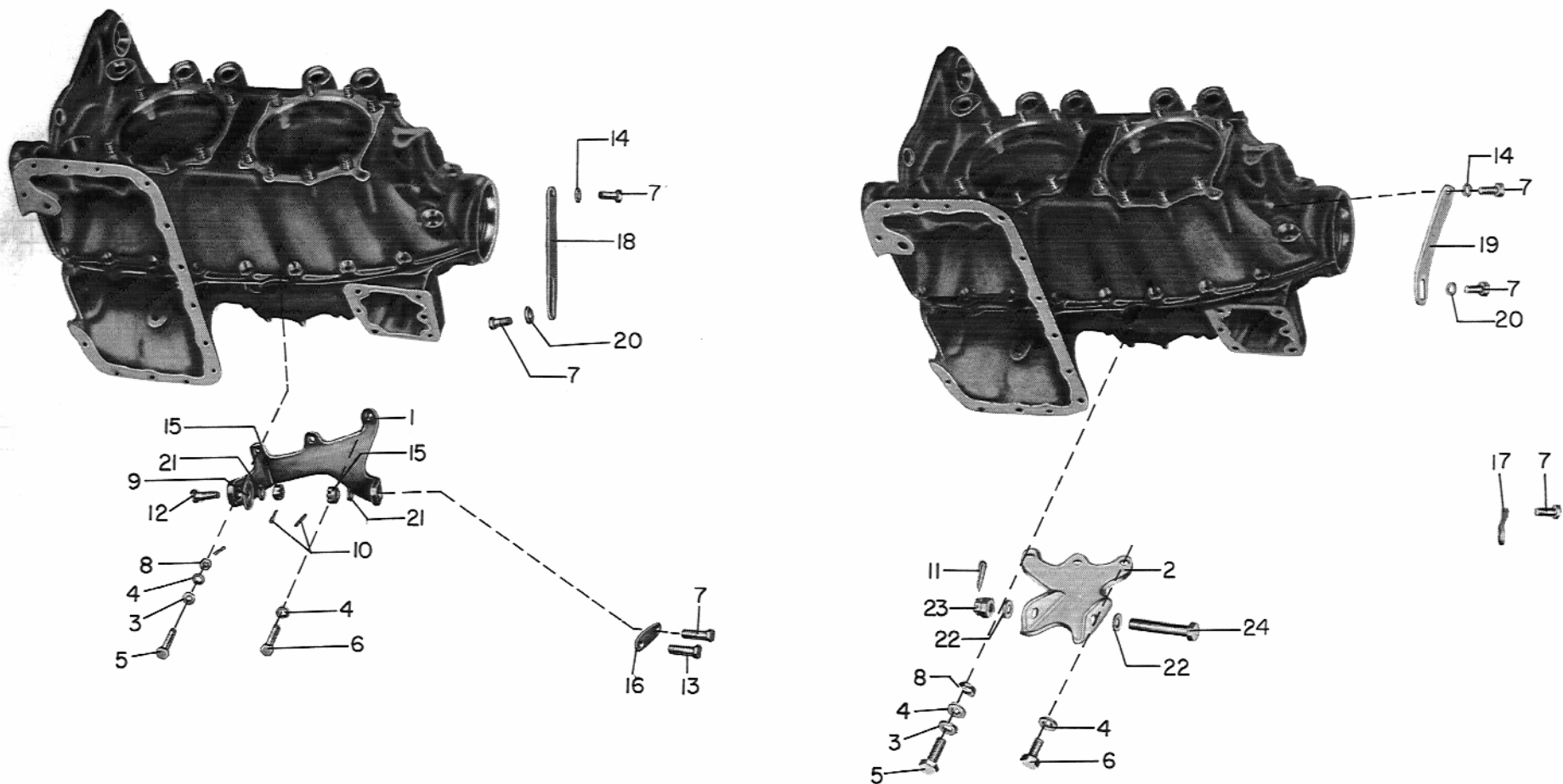

Generator /Alternator Brackets - Standard Cylinder Flange Engines

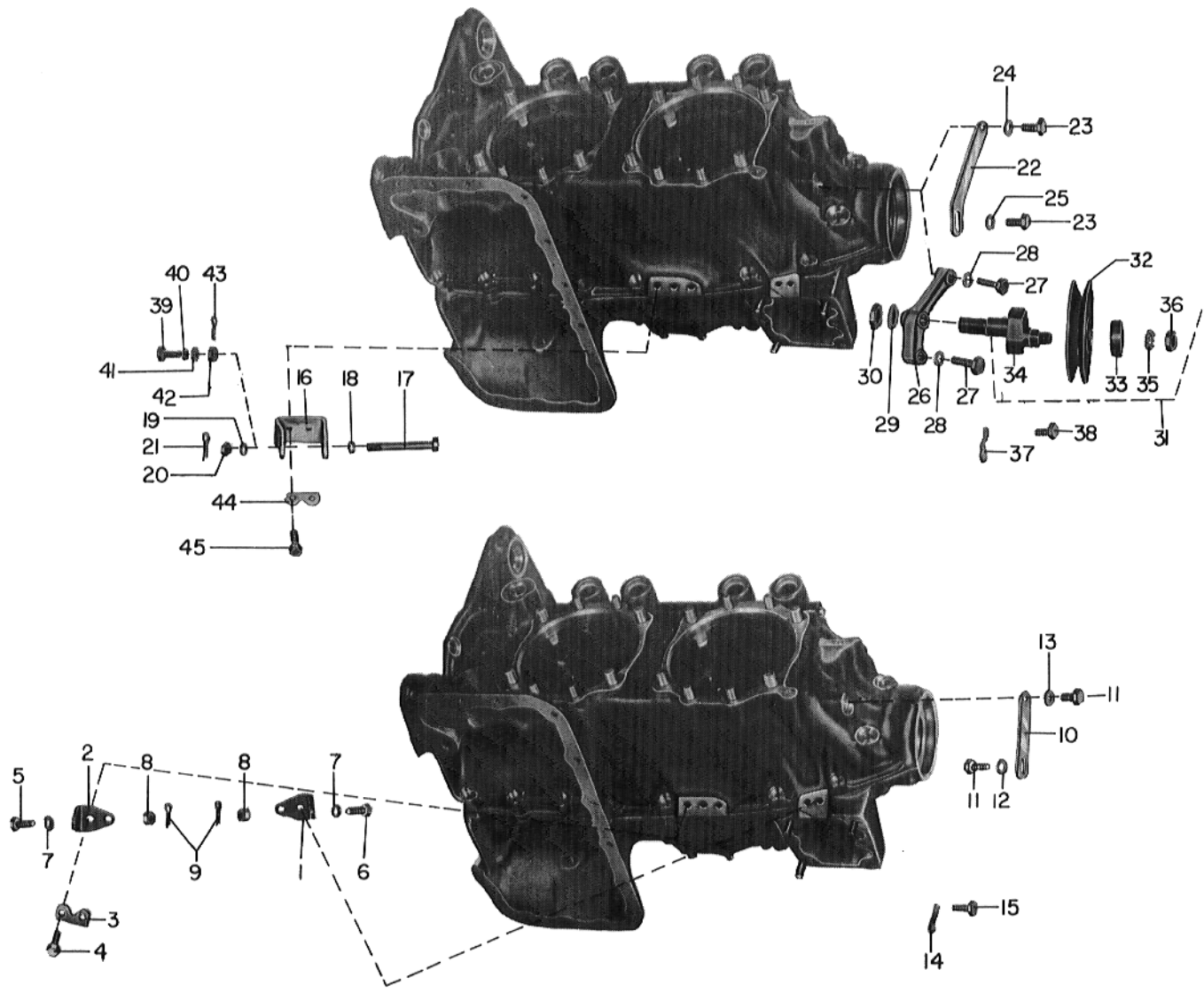

Figure 5-2. Generator/Alternator Bracket - Wide Cylinder Flange Engines

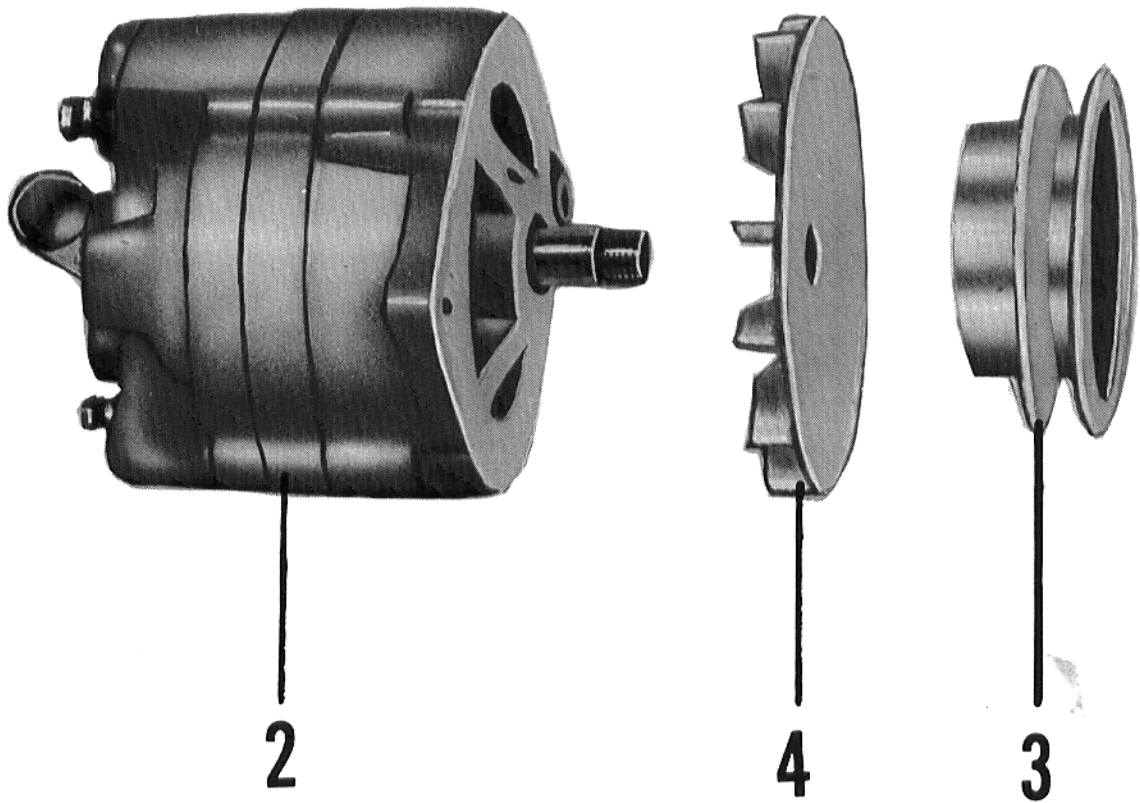
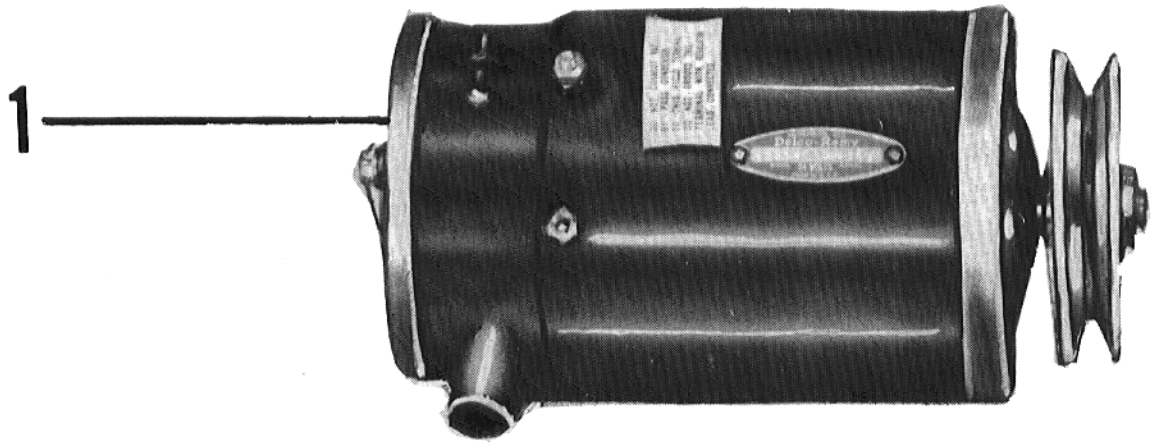

Figure 5-3. Generator and Alternator

1	76026	BELT, Alternator drive, 3/8 in.	1
	76211	STARTER, 12 volt, 12/14 pitch, 3.38:1, internal reduction	1
	LW-12083	SWITCH, Magnetic	1

For all other parts except those listed above, use
column headed IO-320-D1A for IO-320-D1B model engines.

VOLTAGE REGULATOR AND RELAY

SECTION
5
PAGE
5-5

REF.	PART NUMBER	DESCRIPTION	QUANTITY PER ASSEMBLY																										
			O-320 SERIES									10-320			L10-320														
			A2A	A2B	A2C	A3A	A3B	A3C	B2A	B2B	B2C	B3A	B3B	B3C	D2A	D2B	D2C	E2A	E2B	E2C	E2D	B7A	B7C	C7A	D7A	E7A	B7A	C7A	
62833		REGULATOR, Voltage, 12V-35A, non-parallel, Delco-Remy 1118704	1	1	1	1	1	1	1	1	1	1	1	1	1	1	1	1	1										1
68626		REGULATOR, Voltage, 12V-35A, parallel, Delco-Remy 1119145	1			1	1	1				1	1															1	
68872		REGULATOR, Voltage, 24V-25A, non-parallel, Delco-Remy 1118799											1																
71350		REGULATOR, Voltage, 24V-25A, parallel, Delco-Remy 1118976						1																					
71745		REGULATOR, Voltage, 12V-50A, non-parallel, Delco-Remy 1119224				1	1	1				1	1	1	1												1		
72077		REGULATOR, Voltage, 12V-50A, parallel, Delco-Remy 1119246						1				1	1													1	1	1	
72205		REGULATOR, Voltage, 12V-20A, non-parallel, Delco-Remy 1119226	1	1			1	1	1	1	1	1	1	1	1				1	1									
74291		REGULATOR, Voltage, 12V-70A, Full transistor, Delco-Remy 9000590				1					1								1	1									
LW-10179		REGULATOR, Voltage, 24V, Full transistor, Prestolite VSF-7403									1								1	1									
LW-10185		REGULATOR, Voltage, 12V, Full transistor, Prestolite VSF-7203				1						1			1				1	1	1	1				1	1	1	1
71979*		REGULATOR, Voltage, 24V-40A, parallel, Delco Remy 1119237	1			1	1	1			1	1	1	1	1	1	1	1	1	1	1							1	
72311*		REGULATOR, Voltage, 24V-40A, non-parallel, Delco-Remy 1119273	1			1	1	1			1	1	1	1	1	1	1	1	1	1	1							1	
74292*		REGULATOR, Voltage, 24V-50A, Full transistor, Delco-Remy 9000591	1			1	1	1			1	1	1	1	1	1	1	1	1	1	1							1	
LW-11139*		REGULATOR, 12 volt, full transistor, for twin engine paralleling system, Prestolite alternators	1			1	1	1			1	1	1	1	1	1	1	1	1	1	1						1	1	1
LW-11140*		REGULATOR, 24 volt, full transistor, for twin engine paralleling system, Prestolite alternator	1			1	1	1			1	1	1	1	1	1	1	1	1	1	1						1	1	1
LW-11357*		REGULATOR, 12 volt, transistorized, Wico - X17990, use with Prestolite internally grounded field alternators - single engine installation	1			1	1	1			1	1	1	1	1	1	1	1	1	1	1						1		
68628**		RELAY, 12 volt, paralleling, Delco-Remy 1116887, use w/reg. 68626, 68810, or 72077	1			1	1	1	1		1	1																1	
71349**		RELAY, 24 volt, paralleling, Delco-Remy 1116902, use w/reg. 71350 or 71979	1			1	1	1			1	1	1	1	1	1	1	1	1	1	1						1	1	1
74661		RELAY, Overvoltage, 12 volt, Delco-Remy 1115831, use w/reg. 74291									1									1	1								
74804*		RELAY, Overvoltage, 24 volt, Delco-Remy 1115832, use w/reg. 74292	1			1	1	1			1	1	1	1	1	1	1	1	1	1	1						1		
78059*		RELAY, Overvoltage, 12 volt, Prestolite X17621, use w/reg. LW-10185 or LW-11139	1			1					1				1	1	1	1	1	1	1						1	1	1
78060*		RELAY, Overvoltage, 24 volt, Prestolite X17620, use w/reg. LW-10179 or LW-11140									1									1	1								
73340		REGULATOR, Voltage, 24V-50A, non-parallel									1																		
		* - Optional equipment.																											
		** - One required each pair of engines.																											

LW-10185	REGULATOR, 12 volt, full transistor	1
78059	RELAY, Overvoltage, 12 volt	1

SECTION

6

**FUEL INDUCTION
SYSTEM**

AVCO LYCOMING PARTS CATALOG

O-320, IO-320 AND LIO-320 SERIES

SECTION 6

FUEL INDUCTION SYSTEM

REF. NO.	PART NUMBER	DESCRIPTION					QTY. PER ENG.
		1	2	3	4	5	
Page 6-1							
1	60096	GASKET, Fuel pump					1
2	75247	FUEL PUMP, Dual diaphragm					1
3	STD-33	WASHER, Plain, 3/8 in.					2
4	STD-1882	SCREW, Socket hd., drilled hd., 3/8-16 x 1-9/32 long					2
5	75686	ELBOW, 5/16 in. tubing, 9/16-18 adjustable 90° (Assemble aft approx. 25° above centerline of fuel pump inlet)					1

NOTE

Parts listed above on Page 6-1 are only parts applicable to IO-320-D1B model engines.

Figure 6-3. Fuel Injector

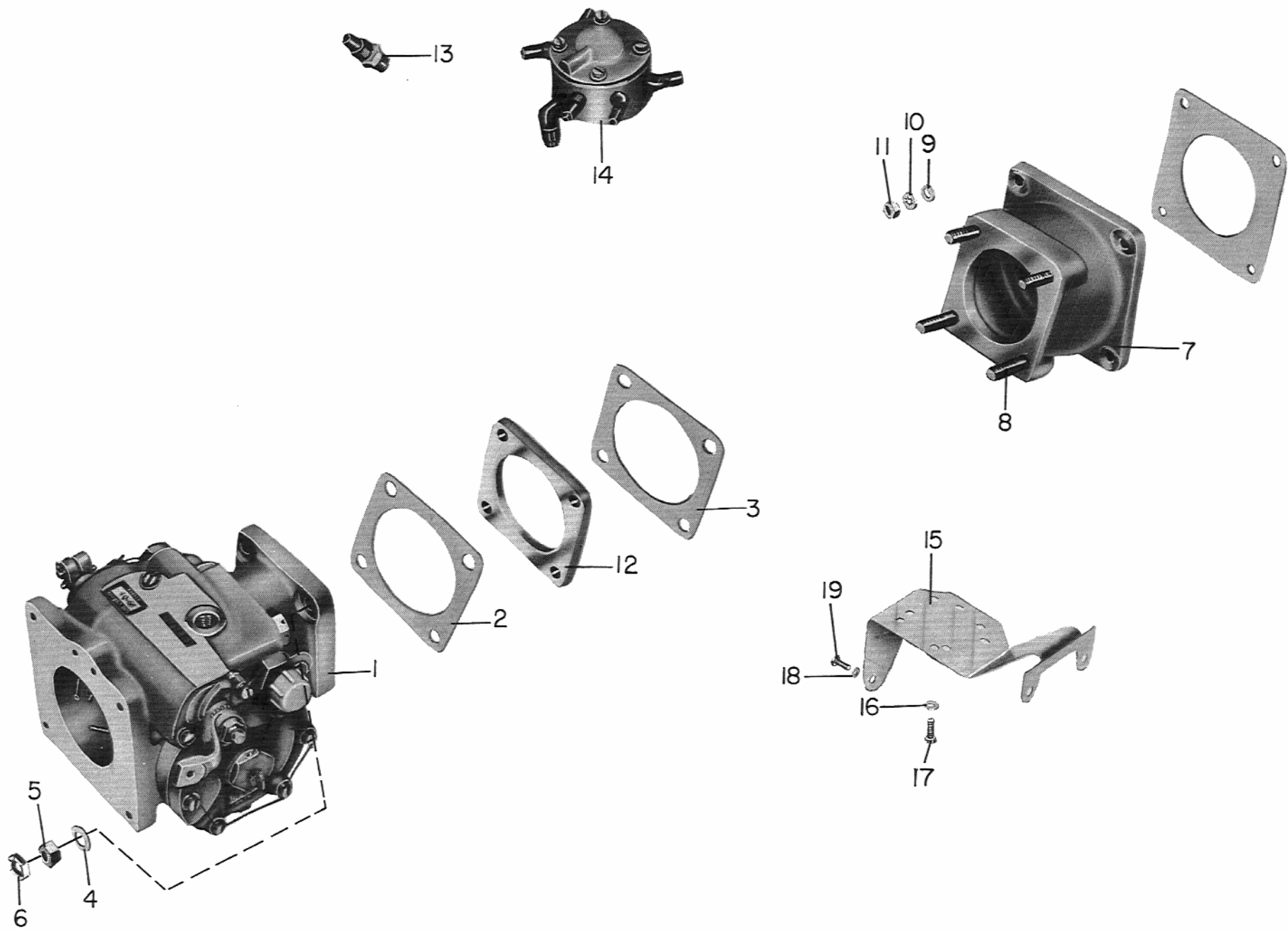

1	LW-12098-200	TUBE ASSEMBLY, Fuel manifold to nozzle, Cyl. No. 1 and 3 (20 in. long)	2
2	LW-12098-1-134	TUBE ASSEMBLY, Fuel manifold to nozzle, Cyl. No. 2 and 4	2
3	72036	CLIP, 3/4 in. ID for 3/16 in. screw	4
5	STD-860	SCREW, Fill. hd., #10-32 x 5/8 in. long	6
7	STD-670	NUT, Self-locking, #10-32	6
	LW-12145	CLIP, 1/8 in. ID for #10 screw	2
	73136	BRACKET, 90°	2

For all other fuel injector plumbing, except those parts listed above, use column listed under IO-320-D1A for IO-320-D1B model engines.

PRIMING SYSTEM

SECTION
6
PAGE
6-5

REF.	PART NUMBER	DESCRIPTION	QUANTITY PER ASSEMBLY																													
			O-320 SERIES												10-320						L10-320											
			A32A	A32B	A33C	A33A	A33B	B33C	B32A	B32B	B33B	B33C	D3A	D3B	D3C	E3A	E3B	E3C	E3D	B1A	B1C	D1A	E2A	B1A	C1A							
1	61581-9	TUBE ASSY., Primer, 16-11/16 in. long, cyls. no. 1 and 2	2	2	2	2	2			2	2	2			2	2	2	2	2	2	2	2			2	2	2	2			2	2
2	61581-2	TUBE ASSY., Primer, 11-11/16 in. long, cyls. no. 3 and 4	2	2	2	2	2			2	2	2			2	2	2	2	2	2	2	2			2	2	2	2			2	2
3	61581-3	TUBE ASSY., Primer, 10-5/16 in. long, intermediate - STD	2	2	2	2	2			2	2	2																				
3	61581-3	TUBE ASSY., Primer, 10-5/16 in. long, intermediate - WCF								1	1	1						1	1	1												
4	62254	CLIP, 3/16 ID, for 1/4 dia. screw	4	4	4	4	4			4	4	4			4	4	4	4	4	4	4	4			4	4	4	4			4	4
5	71909	CLAMP, 1-1/2 ID with 1/4 in. dia. off-set	4	4	4	4	4			4	4	4																				
5	71910	CLAMP, 1-3/4 ID with 1/4 in. dia. off-set																4	4	4												
6	STD-553	SCREW, No. 6-32 x 1/2 in. long	4	4	4	4	4			4	4	4			4	4	4	4	4	4	4	4			4	4	4	4			4	4
7	AN365-632C	NUT, No. 6-32, self-locking	4	4	4	4	4			4	4	4			4	4	4	4	4	4	4	4			4	4	4	4			4	4
8	STD-853	TEE, Union, 1/8 in. tube	3	3	3	3	3			3	3	3			3	3	3	3	3	3	3	3			3	3	3	3			3	3
9	74225	NIPPLE ASSY., Primer	4	4	4	4	4			4	4	4			4	4	4	4	4	4	4	4			4	4	4	4			4	4
	STD-1102	PLUG, 1/8-27 NPT, Allen (assembled in cylinder heads on engines not equipped with priming system)								4	4				4																	

Page 6-5

1102

PLUG, Allen head, 1/8-27 NPT 4

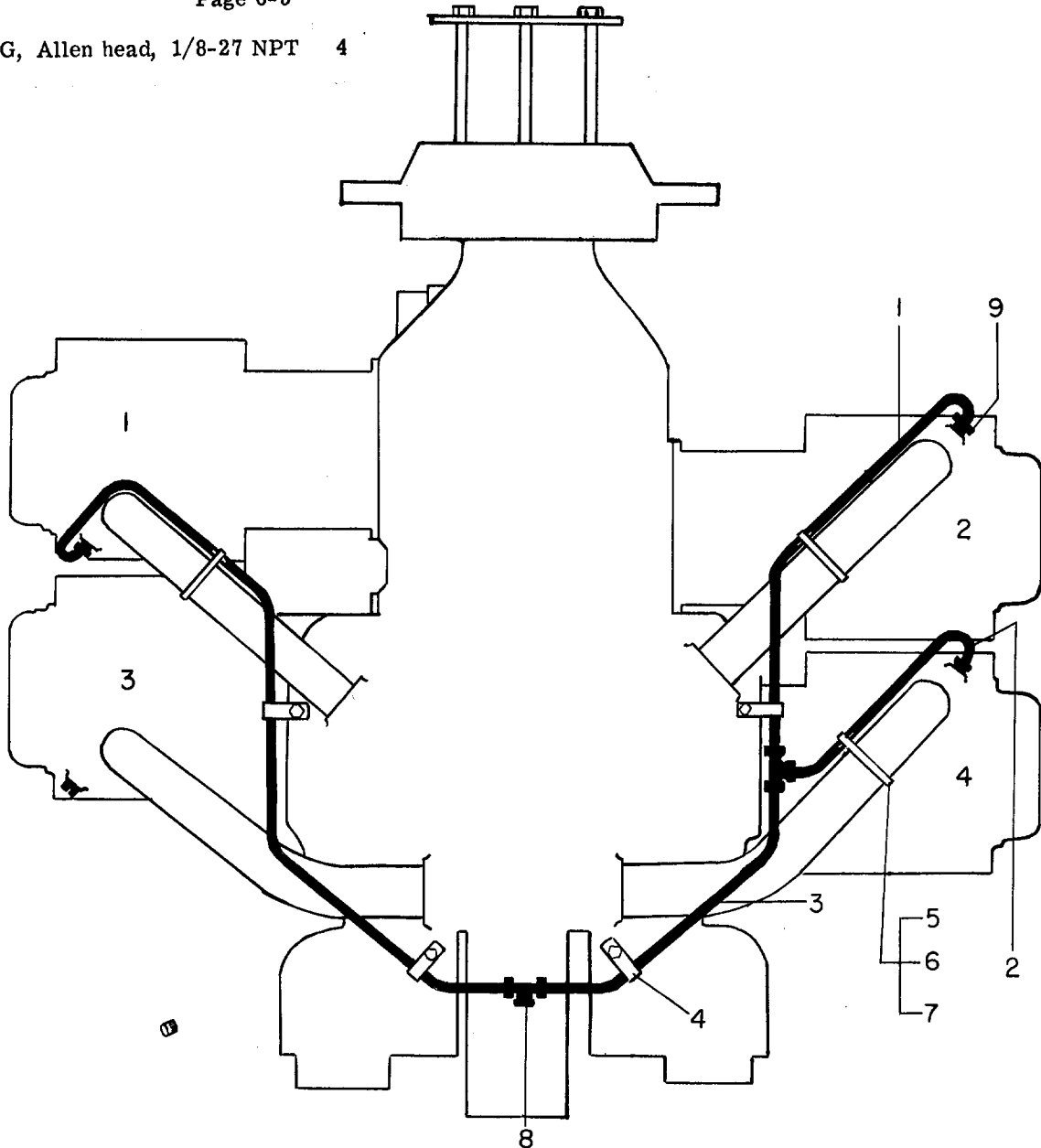

Figure 6-5. Priming System

SECTION

7

**COOLING BAFFLES,
EXHAUST, OIL GAGE
AND PROPELLER
GOVERNOR**

AVCO LYCOMING PARTS CATALOG

O-320, IO-320 AND LIO-320 SERIES

SECTION 7

COOLING BAFFLES, EXHAUST, OIL GAGE
AND PROP GOVERNOR OIL LINE



INTERCYLINDER COOLING BAFFLES

SECTION
7
PAGE
7-1

REF.	PART NUMBER	DESCRIPTION	QUANTITY PER ASSEMBLY																									
			O-320 SERIES												IO-320						LIO-320							
			A2A	A2B	A2C	A3A	A3B	A3C	B2A	B2B	B3A	B3B	B3C	D1A	D2A	D2B	D2C	E2A	E2B	E2C	E2D	B7A	B7C	C7A	D7A	E7A	B7A	C7A
1	72150	BAFFLE ASSY., Intercylinder - STD	2	2	2	2	2	2																				
1	72153	BAFFLE ASSY., Intercylinder - STD																										
1	72569	BAFFLE ASSY., Intercylinder - WCF		2			2	2					2	2	2													
2	71611	RETAINER, Intercylinder baffle	2	2	2	2	2	2	2	2	2	2	2	2	2	2	2	2	2	2	2							
3	71610	HOOK, Intercylinder baffle retainer	2	2	2	2	2	2	2	2	2	2	2	2	2	2	2	2	2	2								

Page 7-1

Use column under IO-320-D1A for IO-320-D1B model engines.

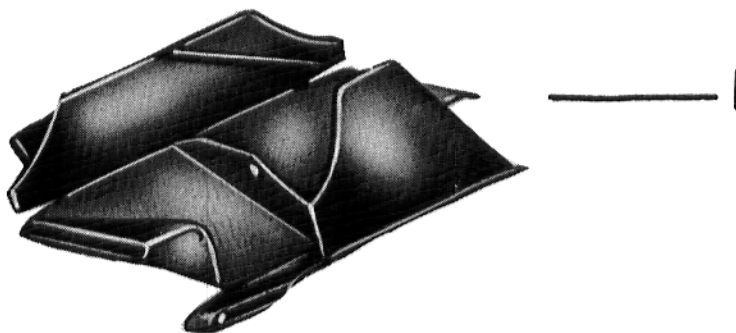
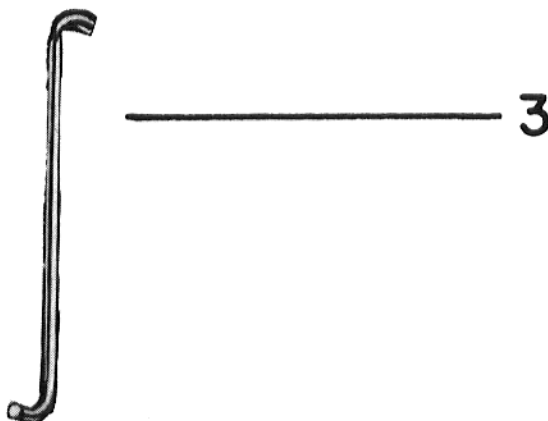
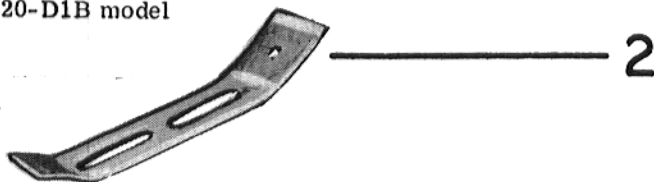

**O-540-A,B,E SERIES, FIA5
MODELS**

Figure 7-1. Intercylinder Cooling Baffles

SECTION

8

**SERVICE
REPLACEMENT SET
SECTION**

AVCO LYCOMING PARTS CATALOG

O-320, IO-320 AND LIO-320 SERIES

SECTION 8

SERVICE REPLACEMENT SET SECTION

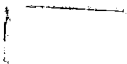

AVCO LYCOMING AIRCRAFT ENGINE GROUP ASSEMBLY PARTS LIST

O-320

SERVICE REPLACEMENT SET SECTION

<u>Part Number</u>	<u>Part Name</u>	
69371-1	SEAL AND GASKET SET	ALL MODELS
	Consisting of:	
2	72053	Gasket - Governor Drive
2	8313	Gasket - Vacuum Pump
16	60053	Seal - Shroud Tube
1	60096	Gasket - Fuel Pump
4	71973	Gasket - Intake Flange
1	60592	Gasket - Carburetor
1	76940 - 77377	Seal - Crankshaft Oil
1	60820	Gasket - Oil Suction Tube Flange
1	74068	Ring - Oil Level Gage Seal
1	61165	Seal - Tachometer Shaft
1	61173	Gasket - Oil Pressure Housing
1	61183	Gasket - Accessory Adapter
4	75906	Gasket - Rocker Box Cover
1	73818	Gasket - Accessory Housing
1	68972	Gasket - Oil Sump
1	61531	Gasket - Hydraulic Valve
4	62224	Gasket - Magneto Adapter
4	65321	Gasket - Exhaust Flange
1	66224	Gasket - Carburetor
4	71481	Seal - Oil
1	68315	Gasket - Accessory Drive Adapter
8	70310	Seal - Shroud Tube
1	STD-208	Seal - Oil
2	STD-294	Gasket - Annular
6	72075	Seal - Oil
2	72091	Ring - Oil Seal
2	STD-1045	Gasket - Annular
1	61523	Container
1	69551	Gasket - Accessory Pad Cover
1	69720	Gasket - Dual Accessory Drive Cover
1	69827	Gasket - Governor Spacer
1	STD-548	Seal - Oil
1	66224	Gasket - Carburetor
1	74065	Ring - Oil Level Gage Seal
1	61156	Lockplate - Crankshaft Gear
2	72078	Lockplate - Camshaft Gear
2	73817	Lockplate - Crankshaft Idler Gear Shaft
4	68518	Lockplate - Shroud Tube
1	76691	Gasket
1	STD-111	Gasket
1	STD-213	Seal
1	1691-C	Gasket
1	69164	Gasket
1	71646	Lockplate
1	72312	Ring - Oil Seal
2	73383	Lockplate
1	74524	Ring - Oil Seal
2	78292	Gasket - Magneto
1	76510	Gasket

SECTION

9

**VENDOR
ACCESSORIES**

AVCO LYCOMING PARTS CATALOG

O-320, IO-320 AND LIO-320 SERIES

SECTION 9

VENDOR ACCESSORIES



AVCO LYCOMING AIRCRAFT ENGINE GROUP ASSEMBLY PARTS LIST

O-320, IO-320, LIO-320 SERIES
SECTION 9 - VENDOR ACCESSORY SECTION
9-1 - DELCO-REMY GENERATORS

REF. NO.	PART NUMBER	1	2	3	4	5	DESCRIPTION	QTY. PER ENG.	MODEL USAGE
	1101899						GENERATOR, 12V-20A, Avco Lycoming 68764	1	A
	1101900						GENERATOR, 12V-25A, Avco Lycoming 68767	1	B
	1101901						GENERATOR, 24V-15A, Avco Lycoming 68765	1	C
	1101905						GENERATOR, 24V-25A, Avco Lycoming 68871	1	D
	1101915						GENERATOR, 12V-50A, Avco Lycoming 71744	1	E
	1105052						GENERATOR, 24V-40A, Avco Lycoming 71980	1	F
	1105055						GENERATOR, 24V-50A, Avco Lycoming 72695	1	G
1	1927842						ARMATURE	1	A
1	1928664						ARMATURE	1	B
1	1928648						ARMATURE	1	C
1	1930314						ARMATURE	1	D
1	1945122						ARMATURE	1	E
1	1945105						ARMATURE	1	F
1	1952240						ARMATURE	1	G
2	1928813						FIELD COIL SET (2 coils)	1	A
2	1925031						FIELD COIL SET (2 coils)	1	B, E
2	1917288						FIELD COIL SET (2 coils)	1	C
2	1929703						FIELD COIL SET (2 coils)	1	D
2	1945098						FIELD COIL SET (2 coils)	1	F
2	1952237						FIELD COIL SET (2 coils)	1	G
3	1943590						FRAME, C. E.	1	A, B, C, D, E
3	1952232						FRAME, C. E.	1	F, G
4	1925832						FRAME, D. E.	1	A, B, C, D, E
4	1945101						FRAME, D. E.	1	F, G
5	954162						BEARING, Ball C. E.	1	A, B, C, D, E
5	900529						BEARING, Ball C. E.	1	F, G
6	954143						BEARING, Ball D. E.	1	A, B, C, D
6	954162						BEARING, Ball D. E.	1	E
6	900529						BEARING, Ball D. E.	1	F, G
7	1908999						PLATE, Brush	1	A, B, C, D, E
8	1906984						BRUSH	2	A, B, C, D, E
8	1906931						BRUSH	2	F, G
9	1903720						SPRING, Brush	2	A, B, C, D, E
9	1908829						SPRING, Brush	2	F, G
10	1850759						ARM, Brush	2	A, B, C, D, E
10	1944373						ARM, Brush	2	F, G
11	1908843						PULLEY	1	
12	1927844						PLATE, Bearing retainer	1	A, B, C, D, E, F
12	1952245						PLATE, Bearing retainer	1	G
13	1909159						TERMINAL STUD AND LEAD	1	A, B, C
13	1858749						TERMINAL STUD	1	D
13	1914186						TERMINAL STUD AND LEAD	1	E
14	1858749						TERMINAL STUD	1	A, B, C, D, F, G
14	1858751						TERMINAL STUD	1	E
15	1908844						THRU BOLT	2	A
15	1908680						THRU BOLT	2	B, C, E
15	1886685						THRU BOLT	2	D, F, G
16	1916747						SHOE POLE	2	A
16	1914618						SHOE POLE	2	B, C, E
16	1939902						SHOE POLE	2	D
16	1918004						SHOE POLE	2	F, G
17	1910131						BAND, Cover	1	A, B, C, D, E
17	1962896						BAND, Cover	1	F, G
18	1861591						COLLAR, Space, outside, D. E.	1	A, B, C, D, E
18	1914198						COLLAR, Space, outside, D. E.	1	F, G
19	1886684						DOWEL PIN, C. E. and D. E.	2	A, B, C, D, E, F
19	809062						DOWEL PIN, C. E. and D. E.	2	G
	1927843						COLLECTOR, Static	1	A, B, C, D, E

AVCO LYCOMING AIRCRAFT ENGINE GROUP ASSEMBLY PARTS LIST

O-320, IO-320, LIO-320 SERIES
SECTION 9 - VENDOR ACCESSORY SECTION
9-1 - DELCO-REMY GENERATORS (CONT.)

REF. NO.	PART NUMBER	1	2	3	4	5	DESCRIPTION	QTY. PER ENG.	MODEL USAGE
	1920738						COLLECTOR, Spring, D. E.	1	F
	1952241						COLLECTOR, Spring, D. E.	1	G
	1952244						COLLECTOR, Ring, D. E.	1	G
	1916748						INSULATOR, Field coil	2	A
	1914491						INSULATOR, Field coil	2	B, C
	1912073						INSULATOR, Field coil	2	D
20	200242						TERMINAL, Clip - to brush (L. H.)	1	A, B, C, D
20	200362						TERMINAL, Clip - to brush	2	E, F, G
	455613						TERMINAL, Clip - to brush (R. H.)	1	A, B, C, D
21	124545						WOODRUFF KEY, D. E.	1	
	1920734						RING, Static collector	1	A, B, C, D, F

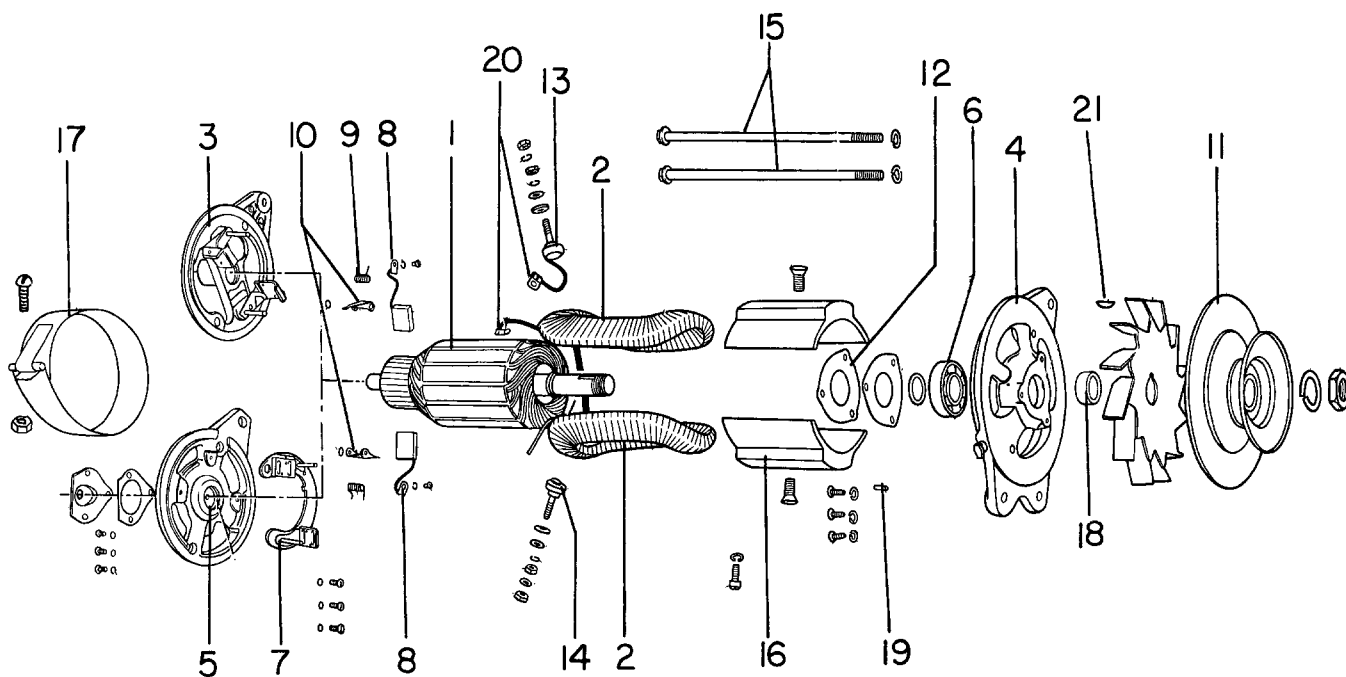

Figure 9-1. Delco-Remy Generator

AVCO LYCOMING AIRCRAFT ENGINE GROUP ASSEMBLY PARTS LIST

O-320, IO-320, LIO-320 SERIES
SECTION 9 - VENDOR ACCESSORY SECTION
9-2 - DELCO-REMY ALTERNATORS

REF. NO.	PART NUMBER	1	2	3	4	5	DESCRIPTION	QTY. PER ENG.	MODEL USAGE
	1100717						ALTERNATOR, 12V-70A, Avco Lycoming 74319	1	A
	1100718						ALTERNATOR, 24V-50A, Avco Lycoming 74816	1	B
1	1964858						FRAME, S. R. E.	1	
2	1964512						ROTOR ASSEMBLY	1	A
2	1964221						ROTOR ASSEMBLY	1	B
3	1961531						STATOR ASSEMBLY	1	A
3	1959531						STATOR ASSEMBLY	1	B
4	1959917						FRAME, D. E.	1	
5	1964354						DIODE	1	
6	1964353						DIODE	1	
7	1965276						BRUSH HOLDER AND BRUSH ASSEMBLY	1	
8	1964117						SPRING, Brush	1	
9	7451326						BEARING, S. R. E	1	
10	905920						BEARING, D. E.	1	
11	1959832						TERMINAL PKG. , Battery	1	
12	1959833						TERMINAL PKG. , Ground	1	
13	1959834						TERMINAL PKG. , Diode junction	1	
14	1963213						BEARING RETAINER ASSEMBLY	1	
15	1953211						COLLAR, Inside	1	
16	1959991						COLLAR, Outside	1	B
17	1961521						THRU BOLT	4	
18	1959455						CAPACITOR	1	
19	1959532						CLIP, Stator lead terminal	3	
20	1964858						HEAT SINK ASSEMBLY	1	
	1952241						COLLECTOR AND SPRING ASSY. , D. E.	1	
	1959389						INSULATOR, Capacitor terminal screw	1	
21	1959790						RETAINER AND FELT, S. R. E.	1	
	1952244						RING, Collector, D. E.	1	
	1961523						SPACER, D. E.	1	
22	1960750						SPRING, Capacitor retaining	1	

AVCO LYCOMING AIRCRAFT ENGINE GROUP ASSEMBLY PARTS LIST

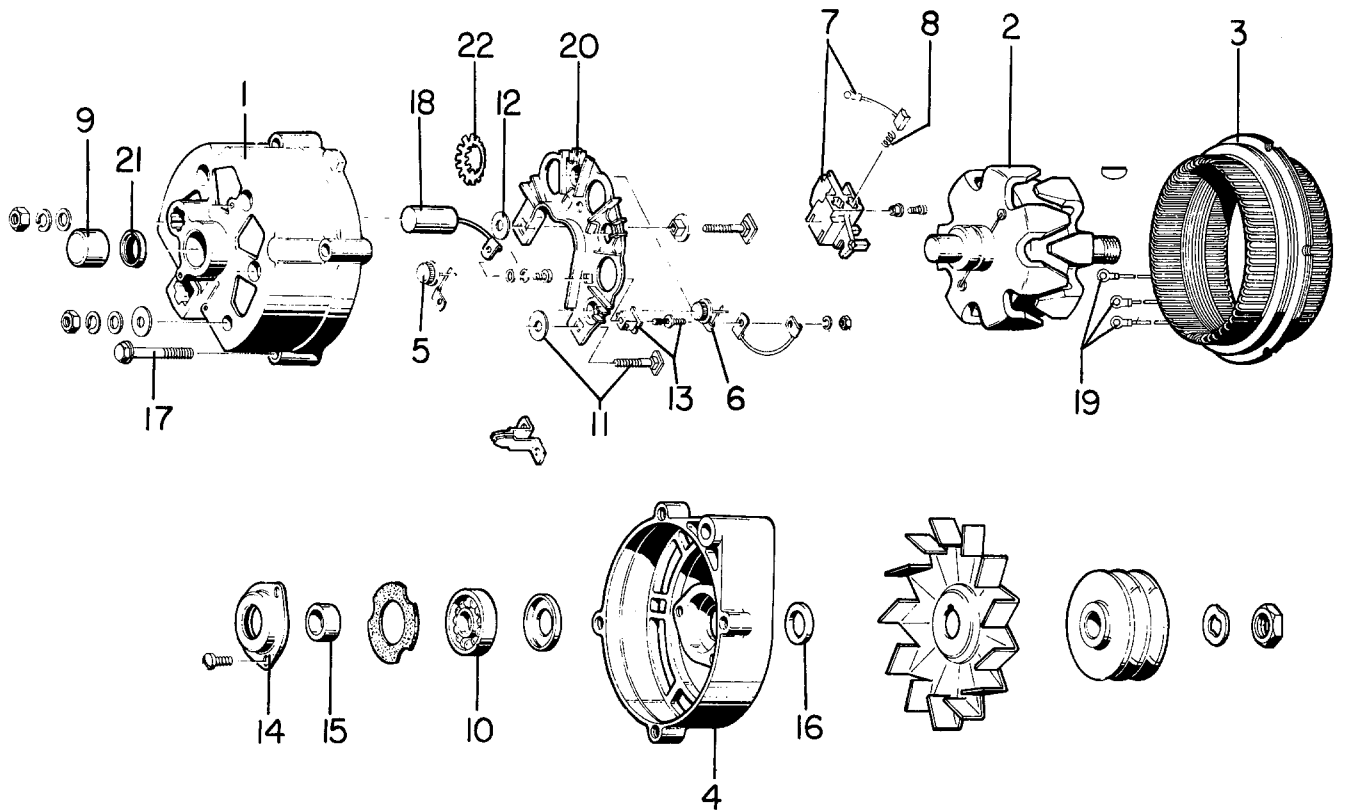

Figure 9-2. Delco-Remy Alternator

AVCO LYCOMING AIRCRAFT ENGINE GROUP ASSEMBLY PARTS LIST

O-320, IO-320, LIO-320 SERIES
SECTION 9 - VENDOR ACCESSORY SECTION
9-3 - PRESTOLITE ALTERNATORS

REF. NO.	PART NUMBER	1	2	3	4	5	DESCRIPTION	QTY. PER ENG.	MODEL USAGE
	ALE-8105A						ALTERNATOR, 12V-40A, Avco Lycoming 76496	1	A
	ALE-8406						ALTERNATOR, 12V-40A, Avco Lycoming 78308	1	B
	ALX-8403						ALTERNATOR, 12V-70A, Avco Lycoming 78310	1	C
	ALT-8404						ALTERNATOR, 24V-50A, Avco Lycoming 78312	1	D
	ALU-8403						ALTERNATOR, 24V-70A, Avco Lycoming 78314	1	E
	ALE-6406						ALTERNATOR, 12V-40A, Avco Lycoming 78401	1	F
	ALZ-8401						ALTERNATOR, 12V-50A, Avco Lycoming 78403	1	G
	ALY-8403						ALTERNATOR, 12V-50A, Avco Lycoming 78407	1	H
	ALY-8405						ALTERNATOR, 12V-60A, Avco Lycoming LW-10372	1	J
	P90-2014						BEARING AND SEAL PKG. , S. R. E.	1	B, C, D, E, F, G, H, J
	ALU-1045A						BRUSH HOLDER ASSEMBLY	1	B, C, D, E, F, G, H, J
1	ALE-1012CS						BRUSH SET, Service	1	A
1	ALE-1012NS						BRUSH SET, Service	1	B, C, D, E, F, G, H, J
2	ALA-19S						SPRING SET, Brush	1	
3	ALE-1062						COVER, Slip ring end	1	A
3	ALU-1062A						COVER, Slip ring end	1	B, C, D, E, F, G, H
3	ALU-1062D						COVER, Slip ring end	1	J
	P90-818						EYELET PKG.	1	B, C, D, E, F, G, H, J
4	PU-1605						FAN, Ventilating	1	A, B, D
4	PU-1605A						FAN, Ventilating	1	C, E, F, G, H, J
5	ALE-1003E						HEAD ASSEMBLY, Drive end	1	A
5	ALE-1003N						HEAD ASSEMBLY, Drive end	1	B, C, D, E, F, G, H, J
6	X-3416						BEARING, Ball SAE No. 203	1	
7	X-3417						BEARING, Roller	1	A
8	ALE-1002LS						HEAD ASSEMBLY, Slip ring end	1	A
8	ALK-1032BS						HEAD ASSEMBLY, Slip ring end	1	B, G, H, J
8	ALK-1032CS						HEAD ASSEMBLY, Slip ring end	1	C, D, E, F
9	XA-944J						RECTIFIER, Negative	3	
10	P90-33						NUT AND WASHER PKG.	1	
11	ALE-4						PLATE, Rectifier mounting	1	A
11	ALE-1054G						PLATE, Rectifier mounting	1	B, C, D, E, F, G, H, J
12	PU-672						PULLEY, Drive	1	
13	XA-943F						RECTIFIER, Positive	3	
14	GR-32						RETAINER, Drive end	1	
15	ALE-2016						ROTOR ASSEMBLY	1	A
15	ALE-2073S						ROTOR ASSEMBLY	1	B, F, G, H, J
15	ALH-2028S						ROTOR ASSEMBLY	1	C
15	ALU-2028S						ROTOR ASSEMBLY	1	D, E
16	ALD-21						SPACER, Rotor shaft	1	
17	ALE-2008Z						STATOR ASSEMBLY	1	A
17	ALE-2008AD						STATOR ASSEMBLY	1	B, F
17	ALE-2008AB						STATOR ASSEMBLY	1	C, E
17	ALE-2008AA						STATOR ASSEMBLY	1	D
17	ALE-2008AG						STATOR ASSEMBLY	1	G
17	ALE-2008AE						STATOR ASSEMBLY	1	H, J
18	P90-356A						TERMINAL STUD AND PARTS PKG.	1	A
18	P90-2030						TERMINAL STUD AND PARTS PKG.	1	B, C, D, E, G, H, J
18	P90-506						TERMINAL STUD AND PARTS PKG.	1	F
19	ALA-20FS						THRU BOLT PKG.	1	A
19	ALA-20JS						THRU BOLT PKG.	1	B, F, G, H, J
19	ALA-20GS						THRU BOLT PKG.	1	C, D, E

AVCO LYCOMING AIRCRAFT ENGINE GROUP ASSEMBLY PARTS LIST

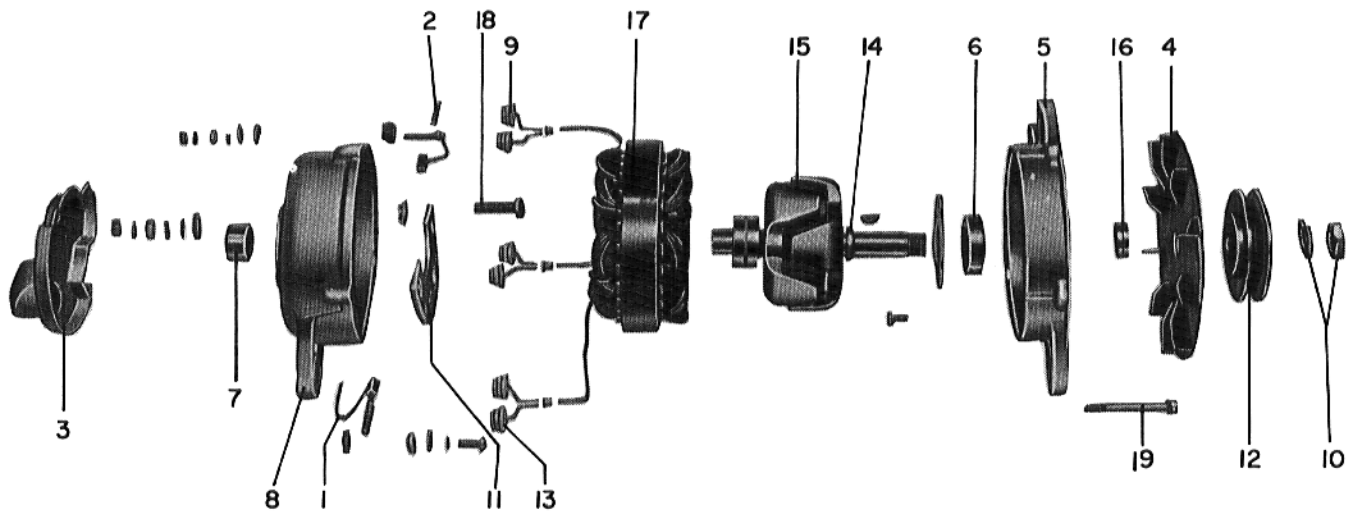

Figure 9-3. Prestolite Alternator

AVCO LYCOMING AIRCRAFT ENGINE GROUP ASSEMBLY PARTS LIST

O-320, IO-320, LIO-320 SERIES
SECTION 9 - VENDOR ACCESSORY SECTION
9-4 - PRESTOLITE STARTERS

REF. NO.	PART NUMBER	DESCRIPTION					QTY. PER ENG.	MODEL USAGE
		1	2	3	4	5		
	MZ4204						1	A
	MZ4206						1	B
	MHB-4001						1	C
	MZ-4216						1	D
1	EBB-124A						1	A
1	EBB-75A						1	B, C
1	EBB-142A						1	D
2	MZ-24A						1	
3	MZ-393						1	B, C, D
4	MZ-394						1	B, C, D
5	MZ-396						1	B, C, D
6	MZ-1390						1	B, C, D
7	XA-997						1	B, C, D
8	XA-998						1	B, C, D
9	MZ-2385						1	A
9	MZ-2397						1	B, D
9	MHB-2397						1	C
10	MZ-2386						1	A
10	MZ-2399						1	B, D
10	MHB-2399						1	C
11	MZ-2002U						1	A
11	MZ-2400						1	B, D
11	MHB-2400						1	C
12	MZ-19S						1	
13	PS-1435						1	A
13	PS-1432						1	B, C, D
14	MG-77A						1	A
14	MZ-389						1	B, C, D
15	MZ-1236						1	A
15	X-3212						1	B, C, D
16	P90-542						1	A
16	P90-601						1	B, C, D
17	MBG-2012S						1	A, B, D
17	MHB-2012S						1	C
	P90-876						1	D

AVCO LYCOMING AIRCRAFT ENGINE GROUP ASSEMBLY PARTS LIST

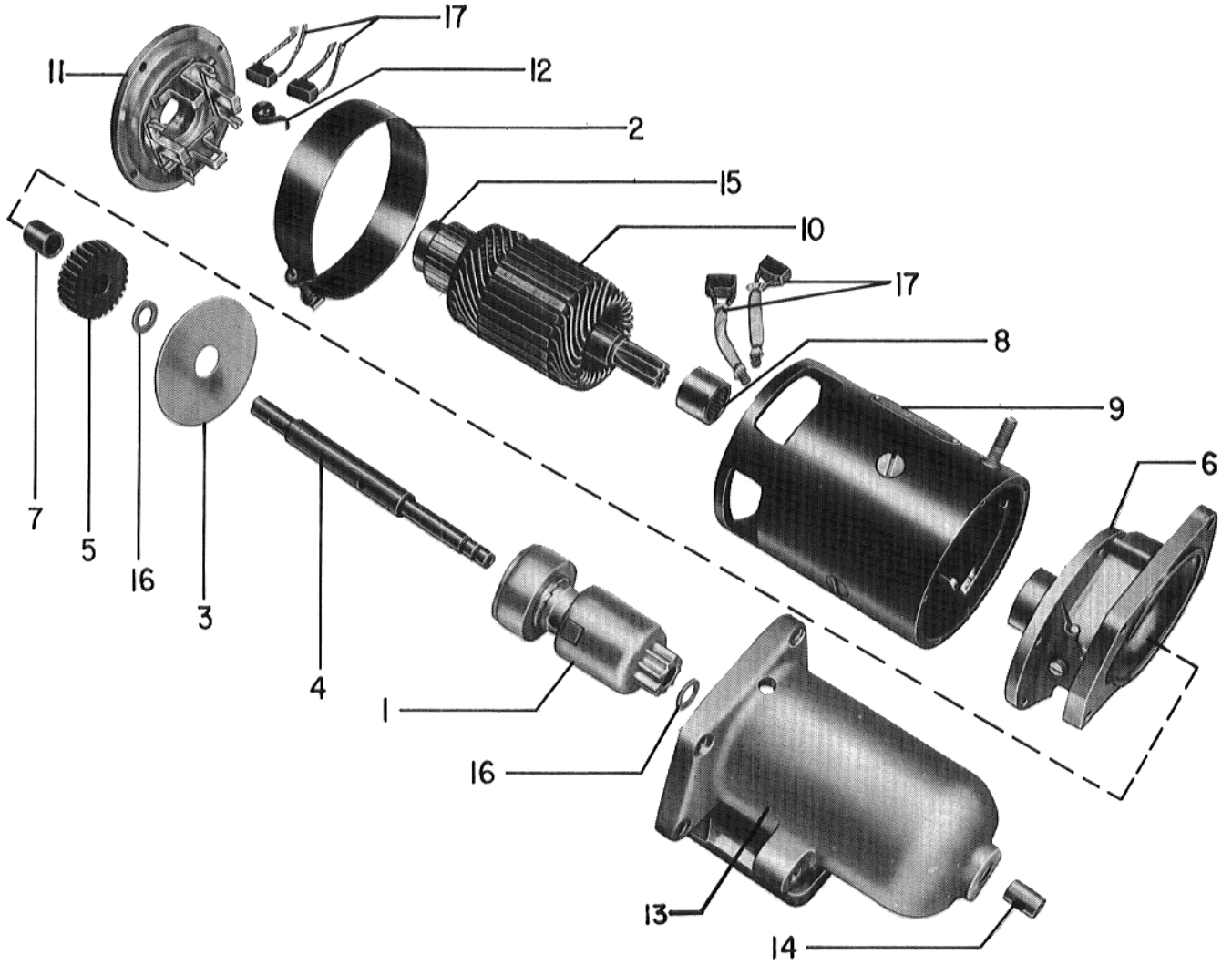

Figure 9-4. Prestolite Starter

AVCO LYCOMING AIRCRAFT ENGINE GROUP ASSEMBLY PARTS LIST

O-320, IO-320, LIO-320 SERIES
SECTION 9 - VENDOR ACCESSORY SECTION
9-5 - BENDIX MAGNETOS, -20 SERIES

REF. NO.	PART NUMBER	1	2	3	4	5	DESCRIPTION	QTY. PER ENG.	MODEL USAGE
	10-51360-25						MAGNETO, S4LN-21, Avco Lycoming P/N 71432	1	A
	10-51360-29						MAGNETO, S4LN-20, Avco Lycoming P/N 71398	1	B
	10-51360-30						MAGNETO, S4LN-21, Avco Lycoming P/N 71397	1	C
	10-51360-45						MAGNETO, S4LN-21, Avco Lycoming P/N 77985	1	D
	10-51360-46						MAGNETO, S4RN-21, Avco Lycoming P/N LW-10518	1	E
1	10-50727Y						HOUSING, Magneto	1	
2	10-157134						PLUG, Ventilator	1	
3	10-357164						COIL	1	A, B, C, E
3	10-357165						COIL	1	D
4	10-50765						CLAMP, Coil core	2	
5	10-35937-8						SCREW, With lockwasher	3	A, B, C, E
5	10-35937-8						SCREW, With lockwasher	2	D
6	10-81806						BEARING, Ball	1	
7	2-161-1						WASHER, Flat, 0.0025 in. thick	AR	
	2-161-2						WASHER, Flat, 0.004 in. thick	AR	
	2-161-3						WASHER, Flat, 0.005 in. thick	AR	
	2-161-4						WASHER, Flat, 0.008 in. thick	AR	
	2-161-5						WASHER, Flat, 0.010 in. thick	AR	
	2-161-6						WASHER, Flat, 0.012 in. thick	AR	
	2-161-7						WASHER, Flat, 0.0015 in. thick	AR	
8	10-52947						MAGNET, Rotating	1	A, C, D, E
8	10-52945						MAGNET, Rotating	1	B
9	10-90788-5						KEY, Woodruff	3	A, C, D, E
9	10-90788-5						KEY, Woodruff	2	B
10	10-157123Y						GEAR, Small	1	
11	10-3503						WASHER, Plain (breaker end bearing)	1	
12	2-199-1						WASHER, Plain 0.0025 in. thick	AR	
	2-199-2						WASHER, Plain 0.004 in. thick	AR	
	2-199-3						WASHER, Plain 0.005 in. thick	AR	
	2-199-4						WASHER, Plain 0.008 in. thick	AR	
	2-199-5						WASHER, Plain 0.010 in. thick	AR	
	2-199-6						WASHER, Plain 0.012 in. thick	AR	
13	2-202						BEARING, Ball (magnet, breaker end)	1	
14	10-88543-1						CAM, Breaker	1	A, B, C, E
14	10-88543-5						CAM, Breaker	1	D
15	10-51354						WASHER, (Cam screw)	1	
16	10-35936-10						SCREW, With lockwasher	1	
17	10-52917						HOUSING, Distributor	1	A, B, C, E
17	10-106498						HOUSING, Distributor	1	D
18	10-157135						PLUG, Distributor housing	1	
19	10-52949						BLOCK, Distributor	1	
20	10-50737						SPRING, Helical (high tension cable contact)	4	
21	10-163374						STRIP, Felt (electrode side)	1	
22	10-50752						WASHER, Felt (ring side)	1	
23	10-102083						SCREW, Distributor block (with plain and lock-washer)	3	
24	10-50746Y						GEAR, Distributor, large	1	
25	10-50753						WASHER, Plain (distributor gear axle)	1	
26	10-92815-37						RING, Retaining (distributor gear axle)	1	
27	10-160844						BRUSH, Electrical contact	1	
28	10-157158						SCREW, With lockwasher (distributor housing to magneto housing)	5	
29	10-357174						CONTACT ASSEMBLY, (Tungsten)	1	A, B, C, E
29	10-382585						CONTACT ASSEMBLY, (Tungsten R. H.)	1	D
30	10-14268						WASHER, Plain (contact assembly)	1	

AVCO LYCOMING AIRCRAFT ENGINE GROUP ASSEMBLY PARTS LIST

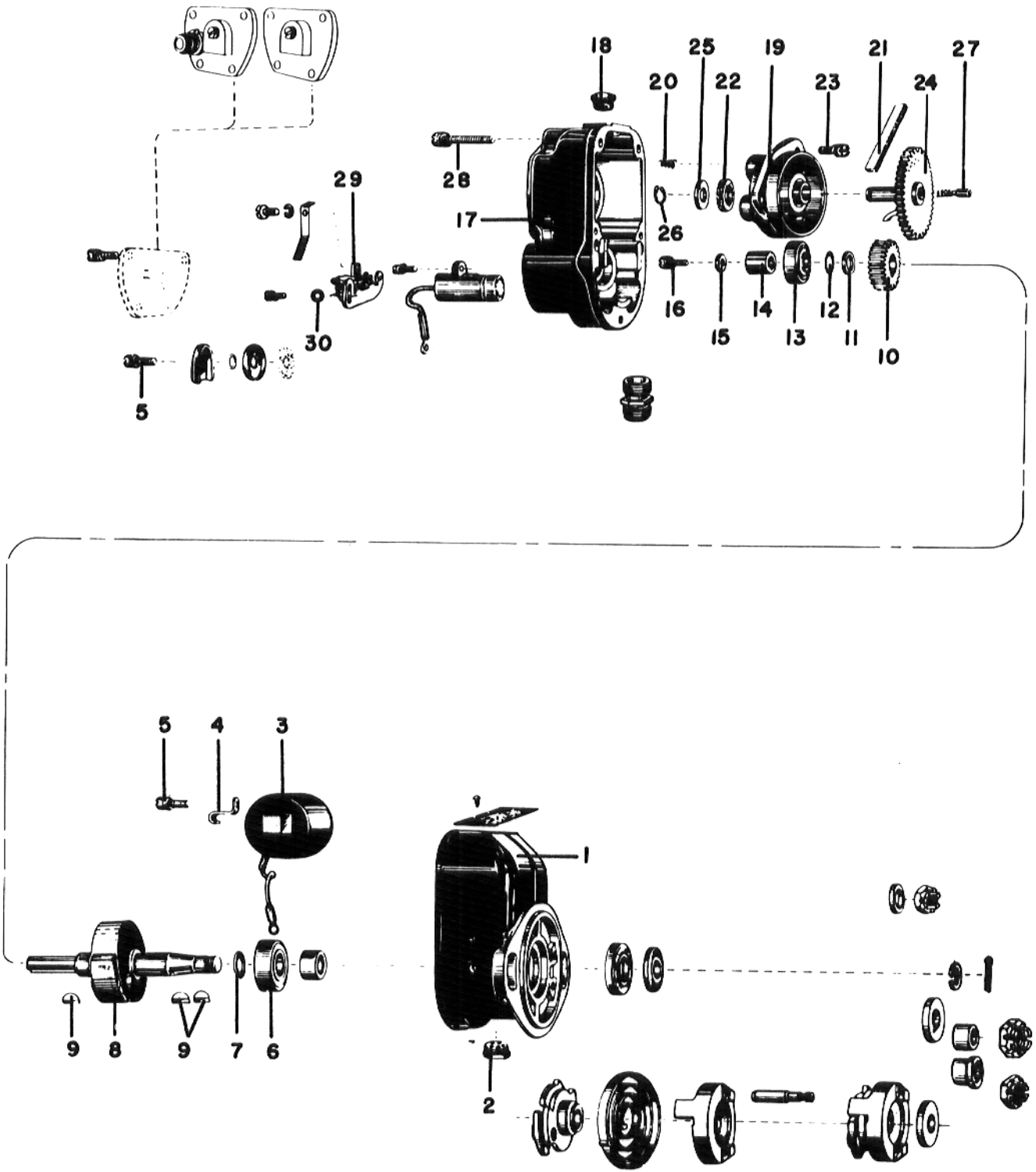

Figure 9-5. Bendix Magneto, -20 Series

AVCO LYCOMING AIRCRAFT ENGINE GROUP ASSEMBLY PARTS LIST

O-320, IO-320, LIO-320 SERIES
SECTION 9 - VENDOR ACCESSORY SECTION
9-5A - BENDIX MAGNETOS, -20 SERIES (CONT.)

REF. NO.	PART NUMBER	1	2	3	4	5	DESCRIPTION	QTY. PER ENG.	MODEL USAGE
1	10-35936-7						SCREW, With lockwasher (contact assy., securing)	2	A, B, C, E
1	10-35936-7						SCREW, With lockwasher (capacitor)	1	A, B, C, E
	10-35935-5						SCREW, With lockwasher	2	D
2	10-51676						CAPACITOR	1	A, B, C, E
2	10-163131						CAPACITOR	1	D
3	10-102090						SPRING, (Ground terminal)	1	A, B, C, E
4	2-194						WASHER, Lock (ground terminal screw)	1	A, B, C, E
5	10-16476						SCREW, Fil. head (ground terminal)	1	A, B, C, E
6	10-52939Y						COVER, Breaker	1	A, B, C, E
7	10-163136						COVER, Breaker	1	D
	10-163177						NUT, Cap, round	1	D
	10-163384						DISK, Neoprene	1	D
8	10-9354						SCREEN, Ventilator (breaker cover)	1	A, B, C, E
9	10-116197						RETAINER, Ventilator screen	1	A, B, C, E
10	10-32438						WASHER, Ventilator shield	1	A, B, C, E
11	10-9967						SHIELD, Ventilator (breaker cover)	1	A, B, C, E
12	10-157161						SCREW, With lockwasher, 0.438 in. long (breaker cover)	4	A, B, C, E
12	10-157160						SCREW, With lockwasher, 0.875 in. long (breaker cover)	4	D
13	10-357078						BEARING, Sleeve (drive shaft)	1	
14	10-27448						OIL SEAL, (Drive Shaft)	1	
15	10-51678						DEFLECTOR, Oil, (drive shaft)	1	
16	10-4093						WASHER, Plain (drive shaft nut)	1	B
17	10-163151						NUT, Drive shaft	1	B
18	10-56513						PIN, Stop, impulse coupling	2	A, C, D, E
19	10-59477						IMPULSE COUPLING, 35° lag	1	A
19	10-59474						IMPULSE COUPLING, 25° lag	1	C, D
19	10-59473						IMPULSE COUPLING, 25° lag	1	E
20	10-59471						CAM, Impulse coupling	1	A
20	10-59437						CAM, Impulse coupling	1	C, D
20	10-59436						CAM, Impulse coupling	1	E
21	10-51324						SPRING, Main, impulse coupling	1	A, C, D, E
22	10-52903						BODY, Impulse coupling	1	A, C, D
22	10-51333						BODY, Impulse coupling	1	E
23	10-51370						WASHER, Plain (impulse coupling)	1	A, C, D, E
24	10-51659						BUSHING, Impulse coupling	1	A, C, D, E
25	10-3793						WASHER, Lock (drive shaft nut)	1	A, C, D, E
26	10-51643						NUT, Drive shaft	1	A, C, D, E
27	10-90751-19						PIN, Cotter (drive shaft nut)	1	
28	10-357012						PLATE, Identification	1	
29	10-90500-5						SCREW, Drive (identification plate)	2	

AVCO LYCOMING AIRCRAFT ENGINE GROUP ASSEMBLY PARTS LIST

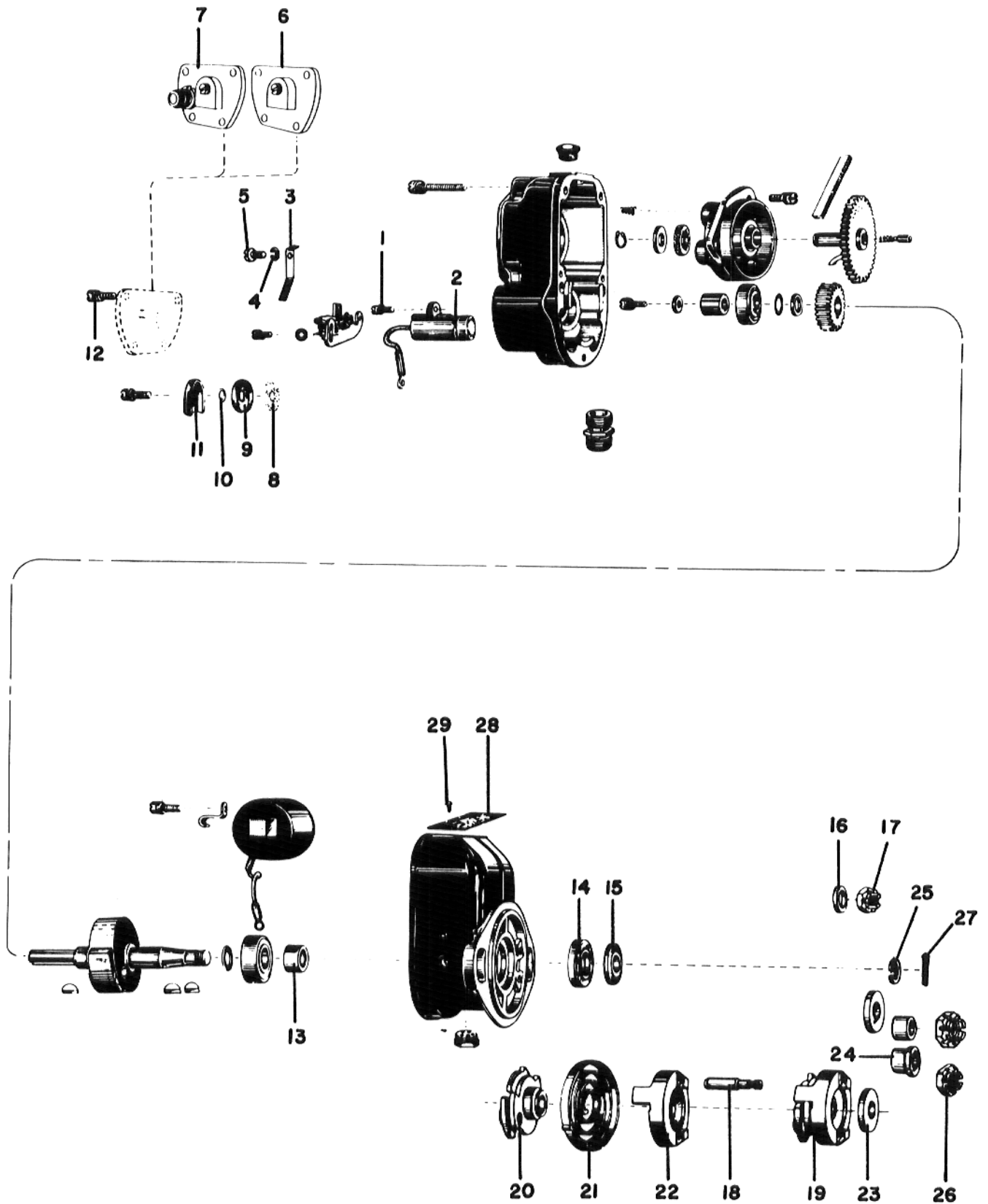

Figure 9-5A. Bendix Magneto, -20 Series

AVCO LYCOMING AIRCRAFT ENGINE GROUP ASSEMBLY PARTS LIST

O-320, IO-320, LIO-320 SERIES
SECTION 9 - VENDOR ACCESSORY SECTION
9-6 - BENDIX MAGNETOS, -200 SERIES

REF. NO.	PART NUMBER	DESCRIPTION					QTY. PER ENG.	MODEL USAGE
		1	2	3	4	5		
	10-163005-2						1	A
	10-163045-3						1	B
	10-163045-6						1	C
1	10-160858						1	
2	10-157134						1	
3	10-157165						1	
4	10-50765						2	
5	10-35937-8						2	
6	10-81806						1	
7	2-161-1						AR	
7	2-161-2						AR	
7	2-161-3						AR	
7	2-161-4						AR	
7	2-161-5						AR	
7	2-161-6						AR	
7	2-161-7						AR	
8	10-52945						1	
9	10-90788-5						2	
10	10-157123Y						1	
11	10-3503						1	
12	2-199-1						AR	
12	2-199-2						AR	
12	2-199-3						AR	
12	2-199-4						AR	
12	2-199-5						AR	
12	2-199-6						AR	
13	2-202						AR	
14	10-88543-5						1	
15	10-51354						1	
16	10-35936-10						1	
17	10-106492						1	A
17	10-106498						1	B, C
18	10-157135						1	
19	10-52949						1	
20	10-50737						4	
21	10-163374						1	
22	10-50752						1	
23	10-102083						3	
24	10-50746Y						1	
25	10-50753						1	
26	10-31282						1	
27	10-160844						1	
28	10-157158						5	
29	10-382584						1	A
29	10-382585						1	B, C
30	10-14268						2	A
30	10-14268						1	B, C
30	10-9858						2	C
31	10-35936-7						4	A, C
31	10-35936-7						2	B
	10-361624						1	C
	10-361639						2	C
32	10-163194						1	A
33	10-157241						1	A
34	10-163131						1	
35	10-35935-5						2	
36	10-163136						1	A, B

AVCO LYCOMING AIRCRAFT ENGINE GROUP ASSEMBLY PARTS LIST

O-320, IO-320, LIO-320 SERIES
 SECTION 9 - VENDOR ACCESSORY SECTION
 9-6 - BENDIX MAGNETOS, -200 SERIES (CONT.)

REF. NO.	PART NUMBER	DESCRIPTION					QTY. PER ENG.	MODEL USAGE
		1	2	3	4	5		
36	10-361637						1	C
37	10-157160						4	
38	10-163384						1	B, C
39	10-163177						1	B
40	10-25788						1	
41	10-27448						1	
42	10-51678						1	
43	10-4093						1	
44	10-163151						1	
45	10-90751-19						1	
46	10-357011						1	
47	10-90500-5						2	

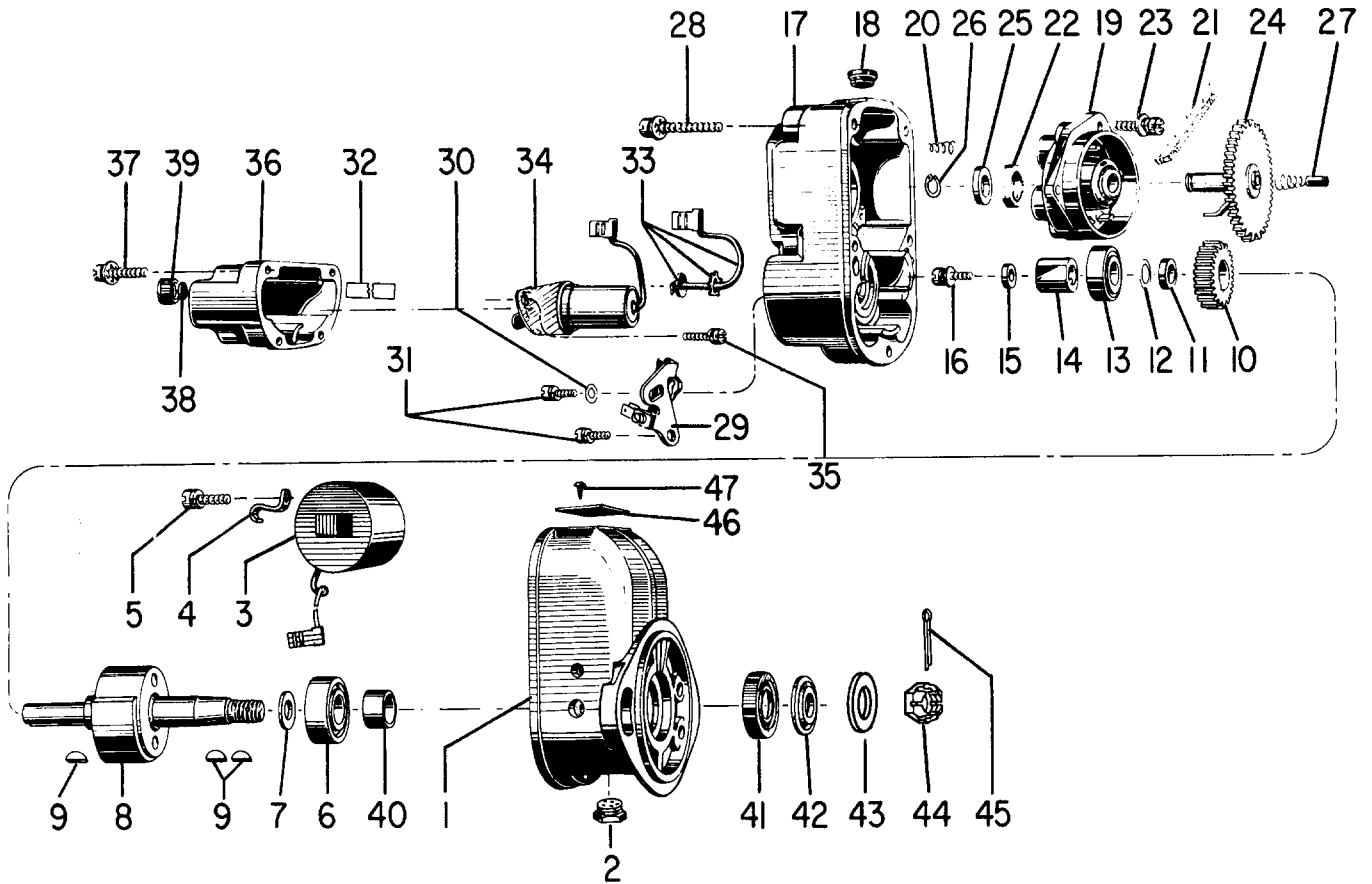

Figure 9-6. Bendix Magneto, -200 Series

AVCO LYCOMING AIRCRAFT ENGINE GROUP ASSEMBLY PARTS LIST

O-320, IO-320, LIO-320 SERIES
SECTION 9 - VENDOR ACCESSORY SECTION
9-7 - BENDIX MAGNETOS, -1200 SERIES

REF. NO.	PART NUMBER	1	2	3	4	5	DESCRIPTION	QTY. PER ENG.	MODEL USAGE
	10-349305-1						MAGNETO, Bendix, S4LN-1209, Avco Lycoming P/N 75896	1	A
	10-349365-2						MAGNETO, Bendix, S4LN-1227, Avco Lycoming P/N 75897	1	B
1	10-35937-24						SCREW, With lockwasher	1	
2	10-92873-302						NUT, Stud and lead contact screw	5	
3	10-90701-5						WASHER, (Stud, outside)	8	
4	10-349393-2						COVER, Magneto	1	
5	10-35935-6						SCREW, Capacitor securing	2	
6	10-349276						CAPACITOR	1	
7	10-349263						PACKING, (Capacitor mounting)	1	
8	10-349221						STUD, Double end (distributor block securing)	4	
9	10-78655						WASHER, (Stud securing)	4	
10	10-92815-37						RING, Retaining, (gear axle)	1	
11	10-349511						WASHER, (Gear axle)	1	
12	10-50752						WASHER, Felt (gear axle)	1	
13	10-349211						BLOCK, Distributor	1	
14	10-50737						SPRING, Helical	4	
15	10-163374						STRIP, Felt	1	
16	10-349234						GEAR ASSEMBLY, Large	1	
17	10-160844						BRUSH, Carbon	1	
18	10-35936-7						SCREW, (Contact assy., and coil lead clamp)	3	
	10-5752						CLIP CABLE (Not illustrated)	1	
19	10-14268						WASHER, (Contact assy., securing screw)	1	
20	10-382585						CONTACT ASSEMBLY, R. H. (Tungsten)	1	
21	10-35936-10						SCREW, (Cam securing)	1	
22	10-51354						WASHER, (Cam securing screw)	1	
23	10-349243-1						CAM	1	
24	10-349326						STRIP, Fish paper	1	
25	10-349219						WEDGE, Coil	2	
26	10-349271						COIL, Magneto (high tension)	1	
27	10-90751-19						PIN, Cotter	1	
28	10-163151						NUT, Castellated (drive shaft)	1	A
29	10-51643						NUT, Castellated (drive shaft)	1	B
30	10-3793						WASHER, Lock, (drive shaft nut)	1	B
31	10-51659						BUSHING, Impulse coupling	1	B
32	10-90788-5						KEY, Woodruff	1	A
32	10-90788-5						KEY, Woodruff	2	B
33	10-4093						WASHER, (Drive shaft nut)	1	A
34	10-51370						WASHER, (Drive shaft nut)	1	B
35	10-349359						IMPULSE COUPLING	1	B
36	10-52903						BODY, Impulse coupling	1	B
37	10-51324						SPRING, Main impulse coupling	1	B
38	10-349357-2						CAM ASSEMBLY, Impulse coupling	1	B
39	10-92815-62						RING, Retaining (drive shaft end)	1	
40	10-349328						WASHER, Flat (flange)	1	
41	10-349249						WASHER, Bowed (flange)	1	
42	10-349248						SLINGER, Oil	1	
43	10-349652						SCREW, (Flange securing)	3	
44	10-53397						WASHER, (Flange securing screw)	3	
45	10-349392-2						FLANGE, Short round (without stop pins)	1	A
45	10-349392-6						FLANGE, Short round (with 2 stop pins)	1	B
46	10-349438R						STOP PIN, Flange	2	B
47	10-353056						BEARING, (Magneto drive end)	1	
48	10-349247						PLATE, (Bearing retaining)	1	
49	10-349351-3						MAGNET, Rotating	1	A
49	10-349351-1						MAGNET, Rotating	1	B
50	10-349241						GEAR, Distributor, (small)	1	

AVCO LYCOMING AIRCRAFT ENGINE GROUP ASSEMBLY PARTS LIST

O-320, IO-320, LIO-320 SERIES
 SECTION 9 - VENDOR ACCESSORY SECTION
 9-7 - BENDIX MAGNETOS, -1200 SERIES (CONT.)

REF. NO.	PART NUMBER						DESCRIPTION	QTY. PER ENG.	MODEL USAGE
		1	2	3	4	5			
51	10-157134						VENTILATOR	1	
52	10-157135						PLUG, Timing	1	
53	10-90500-8						SCREW, (Identification plate securing)	2	
54	10-70616						PLATE, Identification	1	
55	10-353060						BEARING, Roller	1	
56	10-349394-3						HOUSING, Magneto	1	

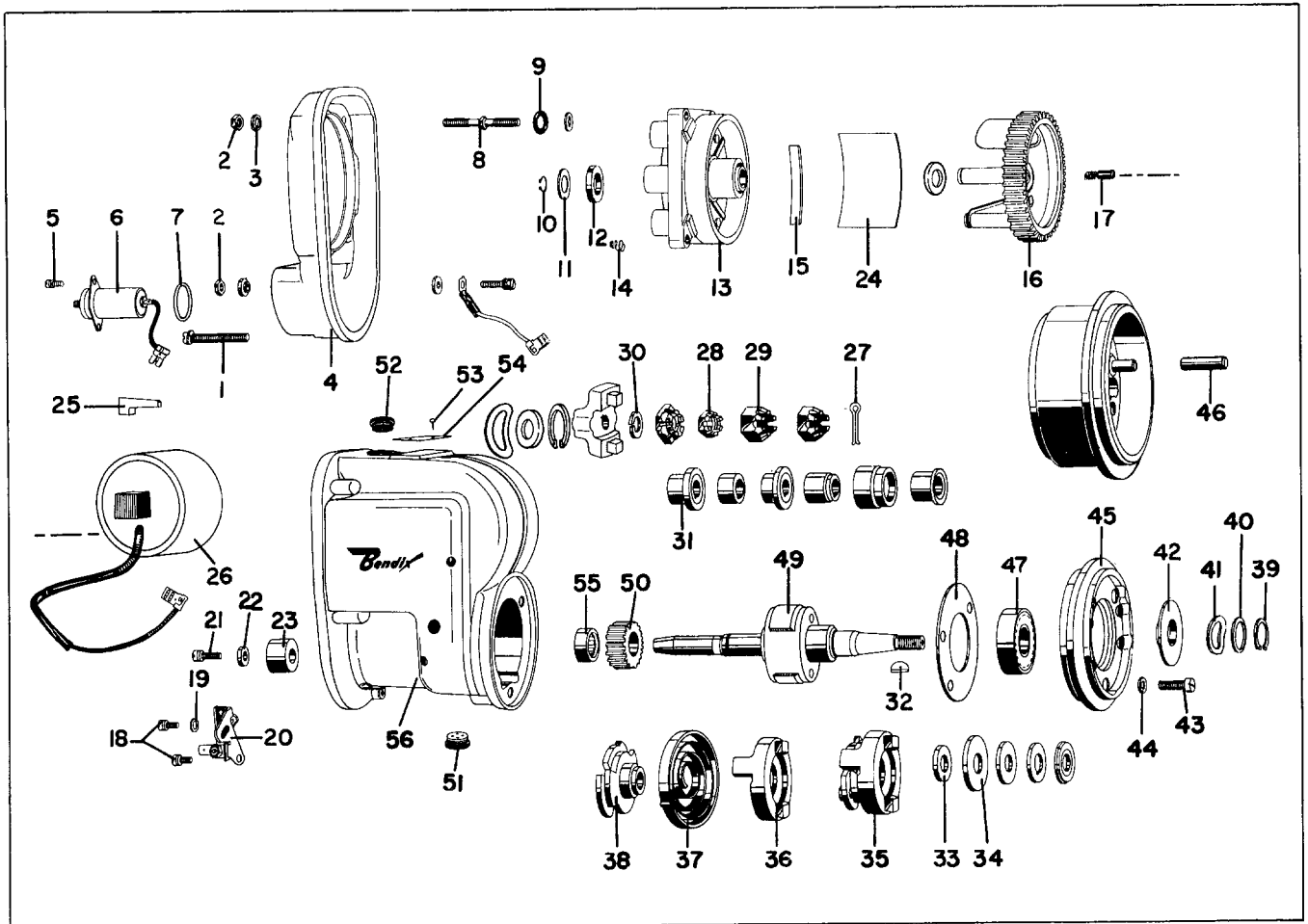

Figure 9-7. Bendix Magneto, -1200 Series

AVCO LYCOMING AIRCRAFT ENGINE GROUP ASSEMBLY PARTS LIST

O-320, IO-320, LIO-320 SERIES
SECTION 9 - VENDOR ACCESSORY SECTION
9-8 - LEAR-SIEGLER FUEL PUMPS

REF. NO.	PART NUMBER	1	2	3	4	5	DESCRIPTION	QTY. PER ENG.	MODEL USAGE
	RG-17980						PUMP, Rotary power driven, fuel, Avco Lycoming 74547	1	A
	RG-17980A						PUMP, Rotary power driven, fuel, Avco Lycoming 76188	1	B
	RG-17980D						PUMP, Rotary power driven, fuel, Avco Lycoming 76486	1	C
1	MS20995NC32						LOCKWIRE	AR	
2	RA7452						SEAL, Metallic	1	
	RB15997						COVER ASSEMBLY	1	
3	AN500A10-22						SCREW, (Attaching part)	4	
4	RA4105						WASHER, Flat (attaching part)	4	
5	RB15996						CAP, Valve	1	
6	AN501A10-10						SCREW	1	
7	RA7763						BALL	1	
8	RA7363						SPRING, Relief valve	1	
9	RB15985						VALVE ASSEMBLY, Safety relief	1	
10	RA5575						PLATE, Identification	1	
11	MS21318-1						SCREW, (Attaching)	2	
12	RA9099						PLATE, Instruction	1	
13	MS21318-1						SCREW, (Attaching)	2	
14	RG15982						HOUSING, Valve	1	
15	RA7427						VALVE, Bypass	1	
16	RA7424						SPRING, Bypass valve	1	
17	RA7425						GUIDE, Bypass valve	1	
18	RA15981						GASKET	1	
19	RA7438						PLATE, Thrust	1	
20	RA7491						BLADE, Pump	2	
21	MS16624-1062						RING, Retaining	1	
22	RB7779-2						SPLINE, Drive	1	A, B
22	RD7779-4						SPLINE, Drive	1	C
23	RA7791						ROTOR, Pump	1	
24	MS16625-1112						RING, Retaining	1	
25	RA6861						SEAL	1	
	RB16043						HOUSING ASSEMBLY	1	
26	RA7493						LINER	1	
27	RS16903-55						PIN, Straight, headless	1	
28	RA7754						BEARING	1	
29	RS16903-55						PIN, Straight, headless	1	
30	RD7492						HOUSING, Pump	1	
31	RA3485-1						PLUG, Pipe	1	A, C
	AN932C2						PLUG, Pipe	3	B

AVCO LYCOMING AIRCRAFT ENGINE GROUP ASSEMBLY PARTS LIST

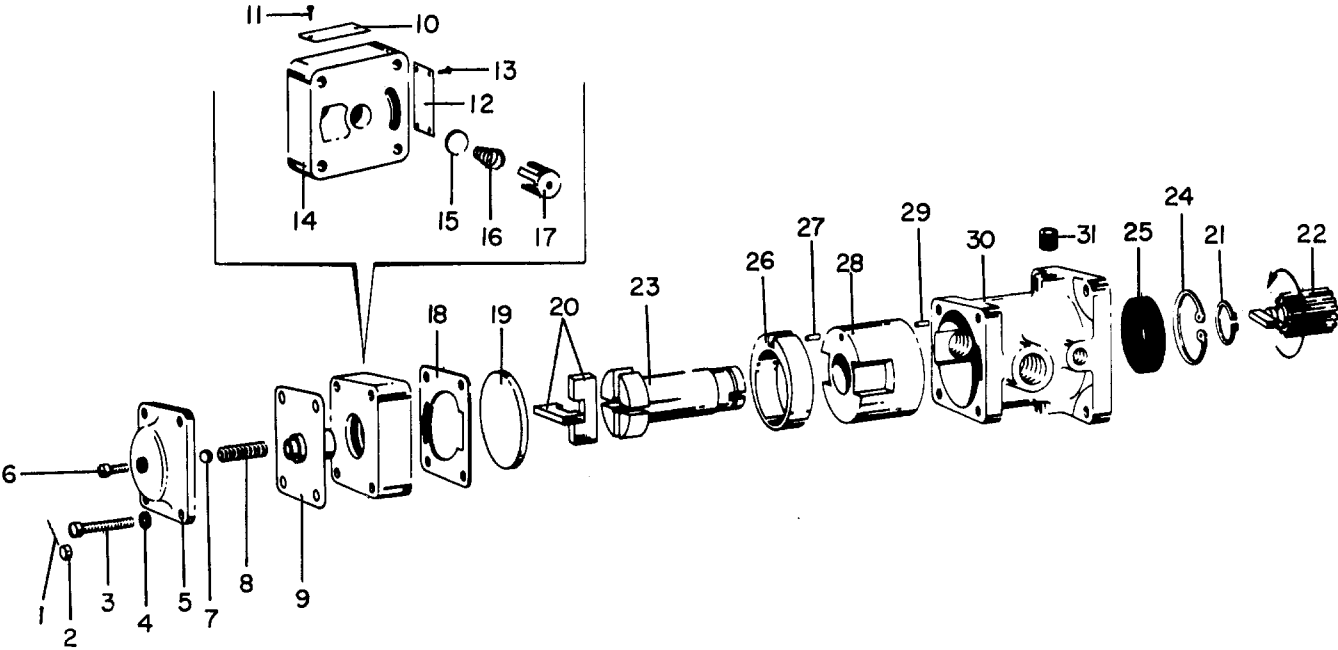

Figure 9-8. Lear-Siegler Fuel Pump

AVCO LYCOMING AIRCRAFT ENGINE GROUP ASSEMBLY PARTS LIST

O-320, IO-320, LIO-320 SERIES
SECTION 9 - VENDOR ACCESSORY SECTION
9-9 - MARVEL-SCHEBLER CARBURETORS, MA-4SPA

REF. NO.	PART NUMBER	DESCRIPTION					QTY. PER ENG.	MODEL USAGE
		1	2	3	4	5		
	10-3678-12						1	A
	10-3678-32						1	B
	10-4910						1	C
	10-5009						1	D
1	10-3689-1						1	A
1	10-4331						1	B, C
1	10-5018						1	D
2	15-474						4	A, B
2	15-B107						4	C, D
3	15-A14						1	A, B
3	15-A14						2	C, D
4	16-222						1	
5	16-224						1	A, B, C
6	16-A16						1	
7	16-A28						1	
8	16-A107						1	
9	17-372						1	
10	24-432						1	
11	36-525						1	
12	36-540						1	
	16-434						1	
13	36-253						1	
14	34-78						1	
15	24-A60						1	
16	36-247						1	
17	99-8						1	A, B
17	99-34						1	C, D
18	37-7						1	
19	47-741						1	A
19	47-773						1	B
19	47-806						1	C
19	47-813						1	D
20	78-5						2	A, B
21	78-121						2	
22	78-345*						4	A
22	78-358						4	B
23	78-A110						4	C, D
23	78-360						4	A
24	82-9						4	A
25	82-11*						1	A, C, D
25	82-11						2	B
26	95-54						1	A, B, D
27	99-8						1	A, B
27	99-34						1	C, D
28	110-173						1	
29	194-581*						1	
30	221-76						1	
31	229-587						1	
	229-550						1	C
	16-676						1	
	286-1063						1	A
	286-1285						1	B
	286-1550						1	C
	286-1568						1	D

* - Indicates part of repair kit.

AVCO LYCOMING AIRCRAFT ENGINE GROUP ASSEMBLY PARTS LIST

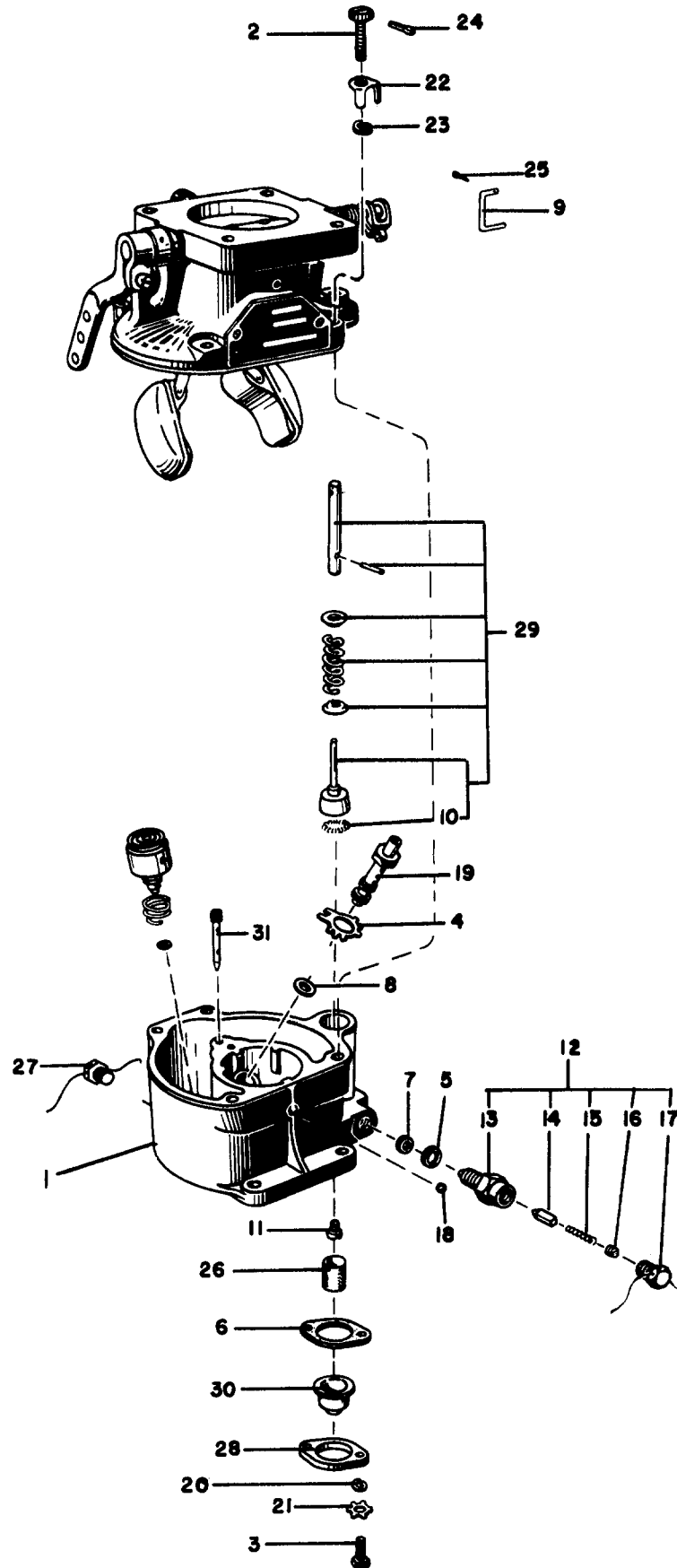

Figure 9-9. Marvel-Schebler Carburetor, MA-4SPA

AVCO LYCOMING AIRCRAFT ENGINE GROUP ASSEMBLY PARTS LIST

O-320, IO-320, LIO-320 SERIES
SECTION 9 - VENDOR ACCESSORY SECTION
9-9A - MARVEL-SCHEBLER CARBURETORS, MA-4SPA (CONT.)

REF. NO.	PART NUMBER	DESCRIPTION					QTY. PER ENG.	MODEL USAGE
		1	2	3	4	5		
1	227-1488						1	A
1	227-1656						1	B, C
1	227-1929						1	D
2	12-1094						1	C
2	12-798						1	A, B, D
3	13-828*						1	
4	14-190						1	
5	15-A21						2	
6	15-42						1	
7	15-483*						2	
8	15-493						1	A, B, C
8	15-A297						1	D
9	15-A1						1	
10	15-A13						1	A, B
10	15-B108						1	C, D
11	16-224						1	A, B, C
12	16-A28						1	A, B, C
12	44-190						1	C, D
13	16-471						1	
14	16-A222						1	A, B
14	16-A17						1	D
14	16-B75						1	C
15	16-A36						1	
16	24-262						1	
17	24-480						1	
18	24-A56*						1	
19	24-A10						1	
20	29-113						3	
21	30-628						1	A, B
21	30-759						1	C, D
22	32-32						1	
23	37-7						1	
24	43-564						1	
25	44-49						1	
26	46-A33						1	
27	46-A2						1	
28	49-180						1	B, C
29	55-270						1	A, B, D
30	60-260						2	
31	78-184						1	
32	78-184						1	
33	78-356						1	
34	78-357						1	A, B
34	78-A-109						1	C, D
35	78-388						1	
36	82-11						1	
37	82-11						1	
38	95-509						1	
39	136-58						1	
40	155-226						1	A, B, C
41	155-597						1	
42	233-583						1	A, B
42	233-615						1	C, D
43	242-514						1	
	29-184						1	C
	29-193						1	C, D
	78A-128						1	D

* - Indicates part of repair kit.

AVCO LYCOMING AIRCRAFT ENGINE GROUP ASSEMBLY PARTS LIST

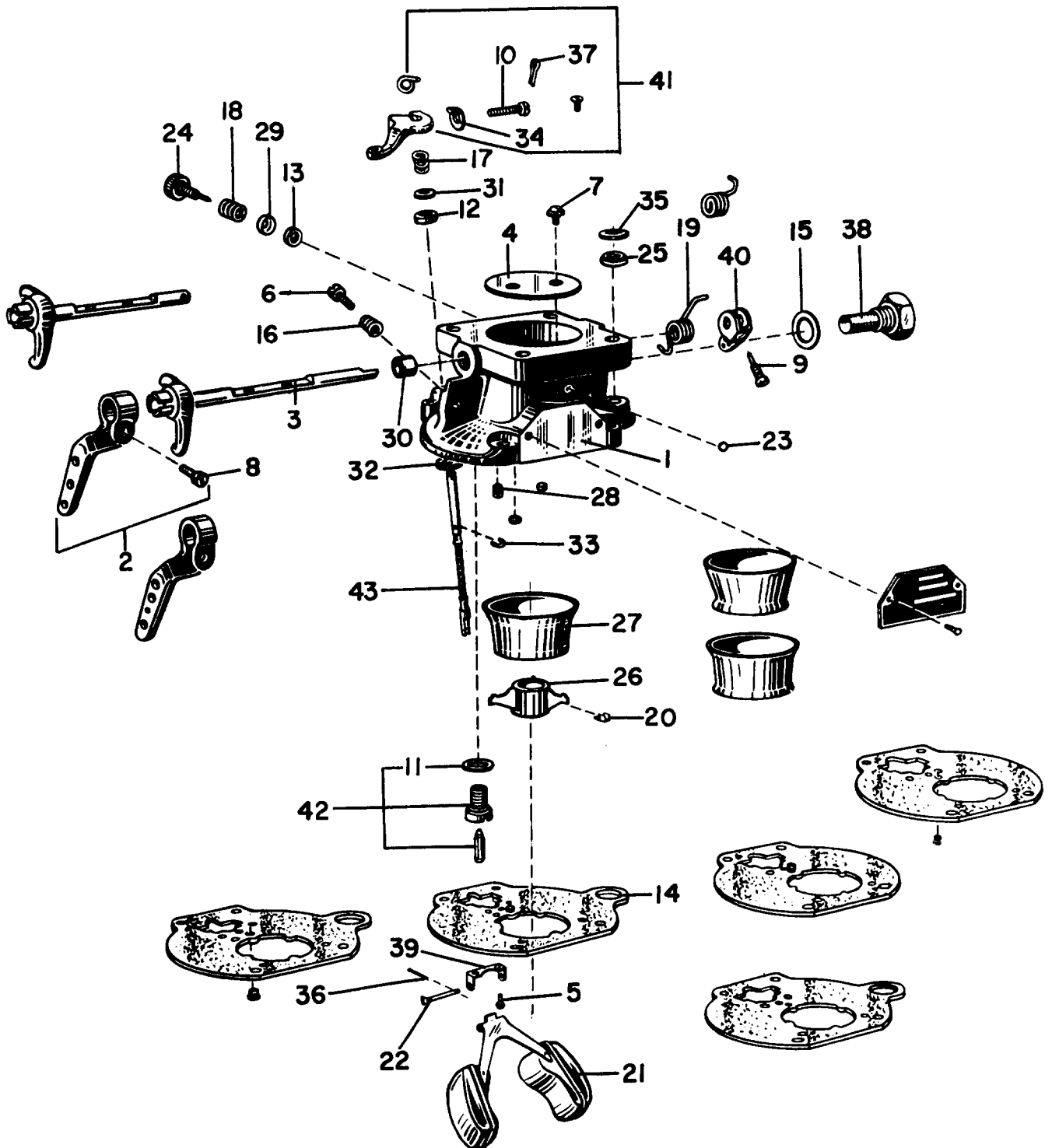

Figure 9-9A. Marvel-Schebler Carburetor, MA-4SPA

AVCO LYCOMING AIRCRAFT ENGINE GROUP ASSEMBLY PARTS LIST

O-320, IO-320, LIO-320 SERIES
SECTION 9 - VENDOR ACCESSORY SECTION
9-10 - BENDIX FUEL INJECTORS, RSA5AD1

REF. NO.	PART NUMBER	DESCRIPTION					QTY. PER ENG.	MODEL USAGE
		1	2	3	4	5		
	2524145-5	FUEL INJECTOR, Bendix, Model RSA5AD1, Avco Lycoming P/N 74534					1	A
	2524242-3	FUEL INJECTOR, Bendix, Model RSA5AD1, Avco Lycoming P/N 76082					1	B
	2524307-3	FUEL INJECTOR, Bendix, Model RSA5AD1, Avco Lycoming P/N 77260					1	C
	2524328-3	FUEL INJECTOR, Bendix, Model RSA5AD1, Avco Lycoming P/N 77543					1	D
	2524335-3	FUEL INJECTOR, Bendix, Model RSA5AD1, Avco Lycoming 77597					1	E
1	328617	SEAL, Aluminum					1	
2	367828	PLATE, Identification					1	
3	186739	SCREW, Self tapping					2	
4	132906	PLUG, Threaded, 7/16-20					2	
5	951787	PACKING, Preformed					2	
6	2522709	PLUG, Machine thread					1	A, B, C, D
7	2522712	STRAINER ASSEMBLY					1	
8	2522710	ADAPTER					1	
9	951789	PACKING, Preformed					2	
10	P61195	PLUG, Taper seat, 1/4-28					3	
11	367719	ELBOW, Tube 90°					1	
12	367720	NUT, Universal fitting					1	
13	951787	PACKING					1	
14	2525165	SPRING, Helical extension					1	
15	901200K1	PIN, Cotter, 1/2 x 1/16 in.					2	
16	911244	WASHER, Flat					1	
17	177718	WASHER, Spring					1	
18	2522022	PIN, Straight headed					1	
19	901200K1	PIN, Cotter					1	
20	911242	WASHER, Flat					1	
21	P19821	WASHER, Spring					1	
22	2522021	PIN, Straight headed					1	
23	367418	LINK					1	
24	367547	SCREW ASSEMBLY, Idle					1	
25	367544	LINK					1	
26	2522004	LEVER, Mixture control					1	
27	187313	NUT, Self locking, hex, 5/16-24					1	
28	399847	SCREW, Machine, no. 10-24 x 3/4 in.					1	
29	199596	WASHER, Flat					1	
30	2525318	SPACER					1	
31	188595	WASHER, Flat					2	
32	79216	SCREW, Machine, no. 10-24 x 1/2 in.					1	
33	2520879	PLATE, Mixture					1	
34	909281K35	PIN, Spring					1	
35	2523840	BUSHING, Mixture control					1	
36	338491	WASHER, C					1	
37	367694	HOLDER, Spring					1	
38	2523757	SPRING, Helical compression					1	
39	951401	PACKING, Preformed					1	
40	2520878	BUSHING, Sleeve					1	
41	953516-10	PACKING, Preformed					1	
42	2522591	LEVER ASSEMBLY, Mixture control					1	

AVCO LYCOMING AIRCRAFT ENGINE GROUP ASSEMBLY PARTS LIST

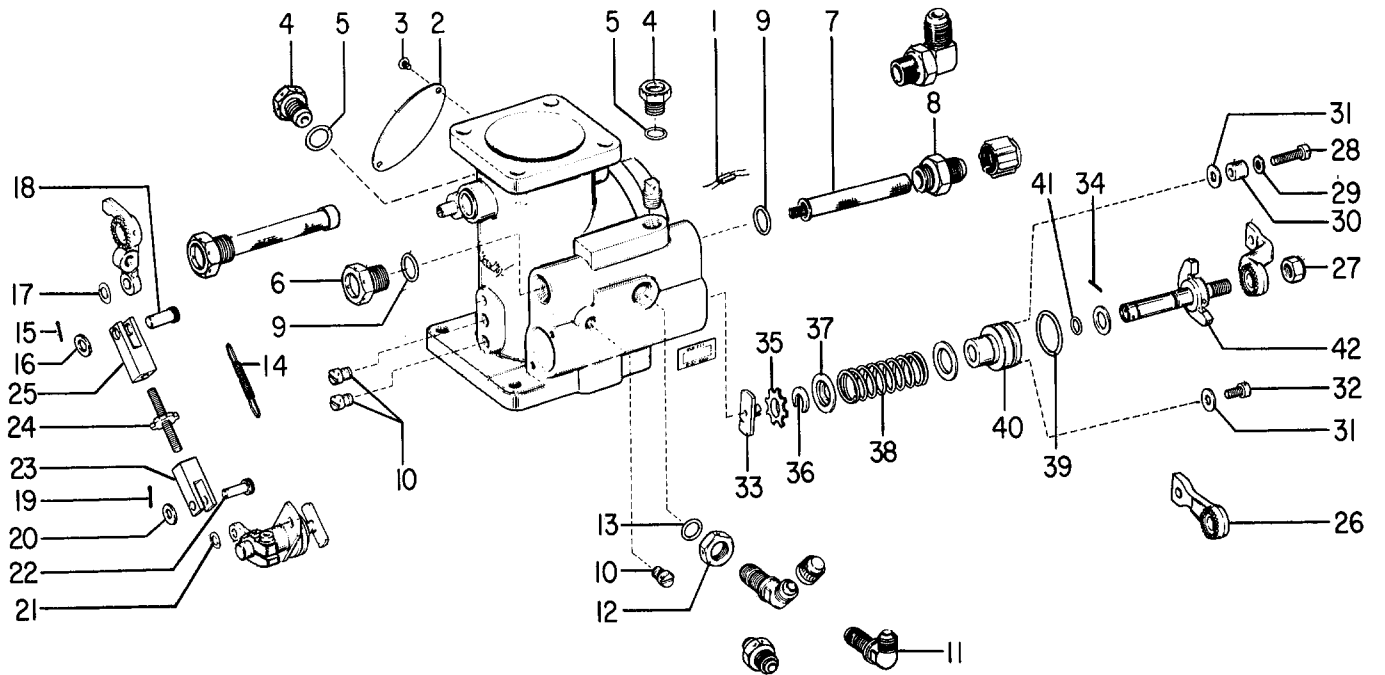

Figure 9-10. Bendix Fuel Injector, RSA-5AD1

AVCO LYCOMING AIRCRAFT ENGINE GROUP ASSEMBLY PARTS LIST

O-320, IO-320, LIO-320 SERIES
SECTION 9 - VENDOR ACCESSORY SECTION
9-10A - BENDIX FUEL INJECTORS, RSA5AD1 (CONT.)

REF. NO.	PART NUMBER	1	2	3	4	5	DESCRIPTION	QTY. PER ENG.	MODEL USAGE
1	2523718						LEVER ASSEMBLY, Idle valve	1	A, B, C
1	2525152						LEVER ASSEMBLY, Idle valve	1	D, E
2	79216						SCREW, Machine, no. 10-24 x 1/2 in.	2	
3	911242						WASHER, Flat	2	
4	P21818						SCREW, Machine, no. 8-32 x 1/2 in.	1	
5	P22198						WASHER, Flat	1	
6	909329K35						PIN, Spring	1	
7	2526408						BUSHING, Idle valve shaft	1	
8	2522326						PLATE, Idle valve	1	
9	367757						WASHER	1	
10	953516-10						PACKING, Preformed	1	
11	951400						PACKING, Preformed	1	
12	2525195						VALVE, Mixture control	1	
13	951400						PACKING, Preformed	1	
14	2525494						PACKING, Preformed	1	
15	2521974						VALVE, Idle	1	A, B, C, E
15	2520626						VALVE, Idle	1	D
16	2537499						NUT, Plain, hex. no. 10-32	1	
17	2537500						SCREW, Stop	1	
18	362842						SCREW, Machine	6	
19	911242						WASHER, Flat	6	
20	2537498						PLUG, Hex, 3/4-20	1	
21	365533						WASHER	1	
22	2523501						COVER	1	
23	178491						NUT, Self-locking, no. 2-56	1	
24	2529180						WASHER, Flat	1	
25	2529181						HOLDER, Spring	1	
26	2520625						SPRING, Helical, compression	1	
27	2529182						BUSHING	1	
28	2529183						BUSHING	1	
29	2529470						DIAPHRAGM ASSEMBLY	1	
30	2520652						SPRING, Helical compression	1	
31	2520882						BODY, Regulator (when exhausted use 2523506)	1	
31	2523506						BODY, Regulator	1	
32	367727						SHIM	AR	
33	2529188						BUSHING ASSEMBLY	1	
34	2529471						DIAPHRAGM ASSEMBLY	1	
35	2529184						SEAT ASSEMBLY	1	
36	2529294						SHIM, Laminated	1	
37	P21819						SCREW, Machine, no. 10-24 x 1/2 in.	1	
38	911242						WASHER, Flat	1	
39	951437						PACKING, Preformed	3	
40	367969						VENTURI ASSEMBLY	1	
41	P70249						TUBE, Impact	4	
42	2523509						VENTURI	1	
43	367639						VALVE, Throttle	1	
44	P4235						SCREW, Machine, no. 8-32	2	
45	901045K12						WASHER	2	
46	2521196						LEVER	1	
47	901209K1						PIN, Cotter, 1/16 x 1/2 in.	1	
48	900848K36						NUT, Castellated, hex, 5/16-24	1	
49	904269K1						SCREW, Machine, 1/4-28	1	C
50	2523432						SCREW ASSEMBLY, Idle adjusting	1	A, B, D, E
51	P60219						SPRING, Helical compression	1	
52	2521976						STOP, Throttle	1	
53	909329K35						PIN, Spring	1	
54	367631						SHAFT ASSY., Throttle	1	
55	2521984						BODY ASSEMBLY, Main	1	

AVCO LYCOMING AIRCRAFT ENGINE GROUP ASSEMBLY PARTS LIST

O-320, IO-320, LIO-320 SERIES
 SECTION 9 - VENDOR ACCESSORY SECTION
 9-10A - BENDIX FUEL INJECTORS, RSA5AD1 (CONT.)

REF. NO.	PART NUMBER	1	2	3	4	5	DESCRIPTION	QTY. PER ENG.	MODEL USAGE
56	2525969						STOP, Throttle	1	
57	909311K35						PIN, Spring	1	
58	367725						BUSHING, Sleeve	2	
59	384583						INSERT	4	

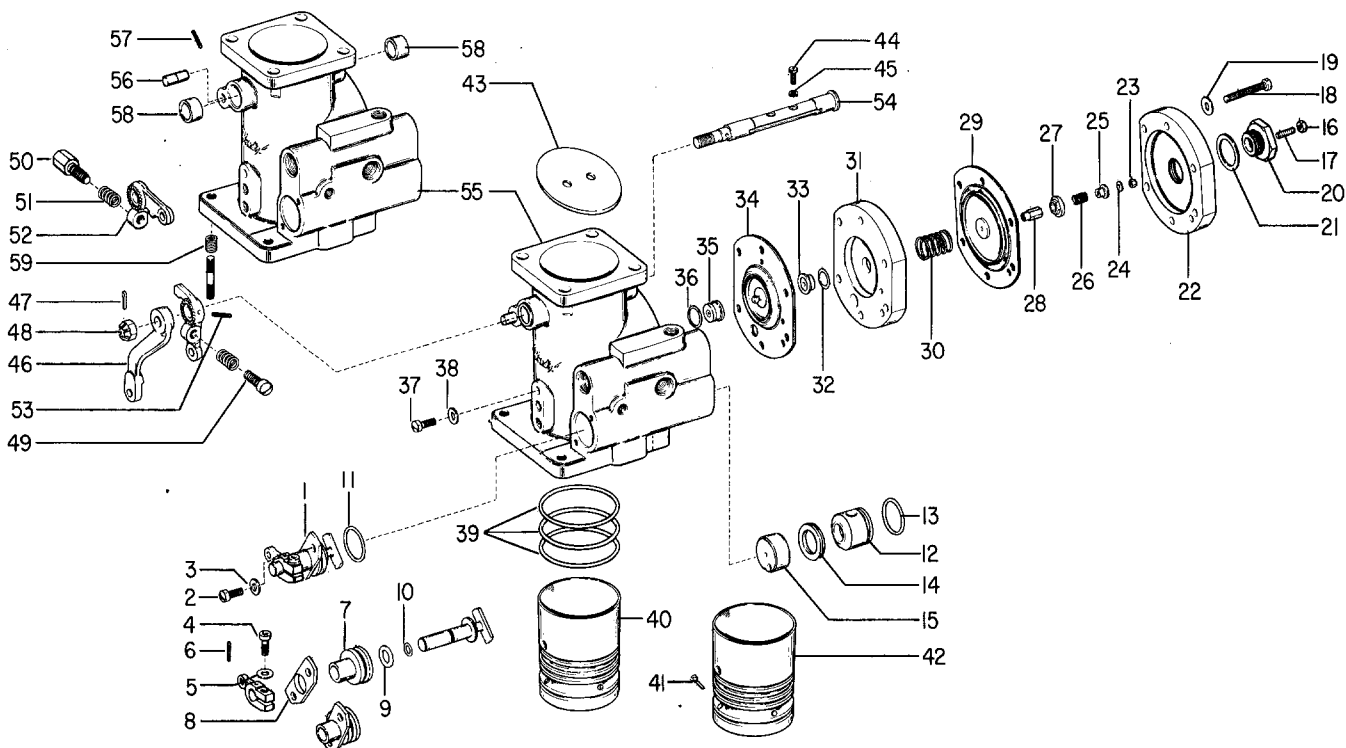

Figure 9-10A. Bendix Fuel Injector, RSA-5AD1

SECTION

10

NUMERICAL INDEX

AVCO LYCOMING PARTS CATALOG

O-320, IO-320 AND LIO-320 SERIES

SECTION 10

NUMERICAL INDEX

AVCO LYCOMING AIRCRAFT ENGINE GROUP ASSEMBLY PARTS LIST

O-320, IO-320, LIO-320 SERIES
 NUMERICAL INDEX PARTS SECTION

PART NO.	FIG-REF. NO.	PART NAME	QTY.	PART NO.	FIG-REF. NO.	PART NAME	QTY.
AN6-12	5-2-17	Bolt	1	STD-8	2-6-9	Washer	4
AN6-13	5-2-39	Bolt	1	STD-8	2-8-7	Washer	6
AN6-14	5-2-17	Bolt	1	STD-8	2-8-8	Washer	2
AN6-16	5-2-39	Bolt	1	STD-8	2-8-9	Washer	24
AN6-32	5-1-24	Bolt	1	STD-8	2-8-14	Washer	AR
AN6-32	5-2-17	Bolt	1	STD-8	2-9-12	Washer	8
AN365-632C	4-2-14	Nut	4	STD-8	2-9-13	Washer	4
AN365-632C	4-3	Nut	4	STD-8	2-9-12	Washer	2
AN365-632C	6-5-7	Nut	4	STD-8	2-9-14	Washer	10
AN380C4-2	2-3-2	Pin	1	STD-8	2-9-15	Washer	16
AN456AD4-8	2-1-17	Rivet	1	STD-8	3-4-25	Washer	8
AN456AD4-22	2-1-18	Rivet	1	STD-8	4-2-16	Washer	2
AN500-416-12	4-2-18	Screw	2	STD-8	4-3	Washer	2
AN500-416-12	4-3	Screw	2	STD-8	4-3	Washer	13
AN500-416-18	4-2-18	Screw	2	STD-8	5-1-3	Washer	1
AN500-416-18	4-3	Screw	2	STD-8	6-4	Washer	1
AN777-8D	2-4-31	Elbow	1	STD-8	7-4	Washer	1
AN822-4-4	6-4-9	Elbow	1	STD-33	1-5-1	Washer	4
AN822-5-4D	7-4-10	Elbow	1	STD-33	1-5-1	Washer	2
AN823-6D	3-2-10	Elbow	4	STD-33	1-5-7	Washer	2
AN844-10D	2-4-33	Elbow	1	STD-33	1-5-8	Washer	2
AN901-8A	2-4-30	Gasket	1	STD-33	1-6-5	Washer	6
AN919-6	6-4	Reducer	1	STD-33	2-6-20	Washer	2
MS13997-3	3-3-10	Key	8	STD-33	5-1-22	Washer	AR
MS13998-3	3-3-11	Cap	4	STD-33	5-2-18	Washer	1
MS16625-1081	1-6-14	Ring	1	STD-33	5-2-18	Washer	AR
MS16625-1125	5-2	Ring	2	STD-33	5-2-19	Washer	AR
MS21919F12	6-4-3	Clip	4	STD-33	5-2-41	Washer	AR
MS29512-6	6-1	Seal	1	STD-33	6-1-3	Washer	2
MS29512-6	6-1-23	"O" Ring	2	STD-33	6-1-8	Washer	2
MS29512-6	6-4	Seal	1	STD-35	2-3-7	Washer	3
MS29512-6	7-4	"O" Ring	1	STD-35	2-6-15	Washer	4
M-1455	4-6-7	Spring	4	STD-35	2-7-6	Washer	4
M-1458	4-6-9	Ferrule	4	STD-35	2-7-11	Washer	4
M-1498	4-6-8	Electrode	4	STD-35	2-7-16	Washer	32
M-1671	4-6-5	Ferrule	4	STD-35	2-7-16	Washer	4
M-1673	4-6-10	Nut	4	STD-35	5-1-14	Washer	1
M-1677	4-6-6	Sleeve	4	STD-35	5-1-21	Washer	AR
M-1735-22	4-6-1	Lead	1	STD-35	5-2-7	Washer	AR
M-1735-23	4-6-3	Lead	1	STD-35	5-2-13	Washer	1
M-1735-29	4-6-2	Lead	1	STD-35	5-2-24	Washer	1
M-1735-29	4-6-3	Lead	1	STD-35	5-4-2	Washer	4
M-1735-30	4-6-4	Lead	1	STD-35	6-1-13	Washer	4
M-1735-32	4-6-1	Lead	1	STD-35	6-1-13	Washer	16
M-1735-36	4-6-4	Lead	1	STD-35	6-1-18	Washer	4
M-1735-38	4-6-2	Lead	1	STD-35	6-2-3	Washer	4
M-1738	4-6-11	Sleeve	4	STD-35	6-3-4	Washer	4
STD-8	1-5-2	Washer	16	STD-35	6-3-9	Washer	4
STD-8	1-5-5	Washer	3	STD-35	7-2-3	Washer	8
STD-8	1-5-6	Washer	AR	STD-35	7-4-7	Washer	3
STD-8	2-3	Washer	2	STD-68	2-8-16	Pin	2
STD-8	2-3-10	Washer	10	STD-68	5-1-10	Pin	2
STD-8	2-3-11	Washer	2	STD-68	5-2-9	Pin	2
STD-8	2-4-6	Washer	3	STD-82	6-3-17	Screw	4
STD-8	2-4-6	Washer	4	STD-91	2-9-10	Plug	1
STD-8	2-4-21	Washer	4	STD-111	2-9-17	Gasket	1
STD-8	2-5-31	Washer	2	STD-160	1-2-6	Washer	6
STD-8	2-5-34	Washer	1	STD-160	1-5-2	Washer	8
STD-8	2-5-37	Washer	3	STD-160	1-5-3	Washer	2
STD-8	2-6-3	Washer	8	STD-160	1-5-3	Washer	1
STD-8	2-6-3	Washer	4	STD-160	1-5-5	Washer	3

AVCO LYCOMING AIRCRAFT ENGINE GROUP ASSEMBLY PARTS LIST

O-320, IO-320, LIO-320 SERIES
 NUMERICAL INDEX PARTS SECTION

PART NO.	FIG-REF. NO.	PART NAME	QTY.	PART NO.	FIG-REF. NO.	PART NAME	QTY.
STD-160	2-3-10	Washer	10	STD-619	1-1-20	Bushing	8
STD-160	2-3-11	Washer	2	STD-669	5-2-29	Washer	1
STD-160	2-4-20	Washer	1	STD-670	6-4-7	Nut	4
STD-160	2-5-32	Washer	2	STD-670	6-4	Nut	1
STD-160	2-5-35	Washer	1	STD-670	6-4	Nut	2
STD-160	2-5-38	Washer	3	STD-676	5-2-30	Nut	1
STD-160	2-5-42	Washer	1	STD-678	1-5-1	Washer	2
STD-160	2-6-4	Washer	8	STD-684	3-4-16	Nipple	4
STD-160	2-6-4	Washer	4	STD-696	2-5-40	Washer	AR
STD-160	2-6-10	Washer	4	STD-700	7-4-10	Elbow	1
STD-160	2-8-7	Washer	6	STD-705	1-6-17	Screw	4
STD-160	2-8-8	Washer	2	STD-705	1-7-3	Screw	2
STD-160	2-8-9	Washer	12	STD-713	5-1-11	Pin	1
STD-160	2-9-12	Washer	8	STD-713	5-2-21	Pin	1
STD-160	2-9-14	Washer	4	STD-713	5-2-43	Pin	1
STD-160	2-9-14	Washer	10	STD-714	2-3-2	Pin	1
STD-160	2-9-15	Washer	8	STD-783	1-1-18	Plug	1
STD-160	2-9-12	Washer	2	STD-783	2-2-19	Plug	1
STD-160	3-4-26	Washer	8	STD-783	2-7	Plug	1
STD-160	4-2-17	Washer	2	STD-784	2-1-12	Plug	1
STD-160	4-3	Washer	2	STD-784	2-2-13	Plug	1
STD-160	4-4	Washer	1	STD-847	1-3-11	Screw	1
STD-160	5-1-4	Washer	3	STD-853	6-5-8	Tee	3
STD-160	6-3-18	Washer	1	STD-860	6-4-5	Screw	4
STD-160	6-4	Washer	1	STD-860	6-4	Screw	1
STD-208	2-5-4	Oil Seal	1	STD-860	6-4	Screw	2
STD-208	2-5-21	Seal	1	STD-872	1-5-7	Nut	1
STD-213	1-7-14	Seal	1	STD-872	1-5-8	Nut	1
STD-251	6-3-16	Washer	4	STD-872	5-1-23	Nut	1
STD-294	2-4-5	Gasket	1	STD-872	5-2-20	Nut	1
STD-294	2-4-5	Gasket	2	STD-872	5-2-42	Nut	1
STD-294	2-4-24	Gasket	1	STD-938	2-5-27	Dowel	1
STD-294	2-4-28	Gasket	1	STD-957	4-2-5	Grommet	4
STD-295	4-7-3	Gasket	8	STD-1006	2-1-19	Ring	1
STD-347	3-4-17	Hose	4	STD-1006	2-2-17	Ring	1
STD-406	7-3	Dowel	2	STD-1045	1-2-13	Gasket	1
STD-425	1-2-12	Washer	AR	STD-1045	2-8-18	Gasket	1
STD-425	6-4-6	Washer	4	STD-1065	1-3-3	Dowel	1
STD-425	6-4	Washer	1	STD-1065	1-4-8	Dowel	1
STD-425	6-4	Washer	2	STD-1102	1-1-8	Plug	5
STD-460	6-4	Screw	1	STD-1102	2-1-11	Plug	2
STD-475	2-6-16	Washer	4	STD-1102	2-1-13	Plug	1
STD-475	2-7-7	Washer	4	STD-1102	2-2-12	Plug	2
STD-475	2-7-12	Washer	4	STD-1102	2-2-14	Plug	1
STD-475	2-7-17	Washer	4	STD-1102	2-5-29	Plug	1
STD-475	4-1-7	Washer	4	STD-1102	2-7-3	Plug	1
STD-475	5-4-3	Washer	4	STD-1102	2-9-11	Plug	2
STD-475	6-1-14	Washer	4	STD-1102	3-2	Plug	4
STD-475	6-1-19	Washer	4	STD-1102	6-5	Plug	4
STD-475	6-3-10	Washer	4	STD-1196	3-4-21	Hose	4
STD-475	7-2-4	Washer	8	STD-1197	1-5-1	Bolt	2
STD-475	7-4-8	Washer	1	STD-1198	1-6-6	Bolt	6
STD-514	1-1-13	Dowel	2	STD-1199	1-6-9	Pin	1
STD-548	2-5-22	Seal	1	STD-1202	5-4-4	Bolt	1
STD-551	2-8-6	Plug	1	STD-1204	2-3-10	Bolt	10
STD-551	2-9-9	Plug	2	STD-1204	2-8-7	Bolt	6
STD-553	4-2-13	Screw	4	STD-1204	2-8-9	Bolt	12
STD-553	4-3	Screw	4	STD-1204	2-9-12	Bolt	8
STD-553	6-5-6	Screw	4	STD-1204	2-9-15	Bolt	8
STD-557	1-1-1	Dowel	2	STD-1204	2-9-12	Bolt	2
STD-596	1-5-1	Nut	2	STD-1205	1-5-7	Bolt	1

AVCO LYCOMING AIRCRAFT ENGINE GROUP ASSEMBLY PARTS LIST

O-320, IO-320, LIO-320 SERIES
 NUMERICAL INDEX PARTS SECTION

PART NO.	FIG-REF. NO.	PART NAME	QTY.	PART NO.	FIG-REF. NO.	PART NAME	QTY.
STD-1211	1-3-2	Plug	1	STD-1623	1-1-14	Insert	2
STD-1215	1-5-4	Bolt	2	STD-1727	4-1-6	Washer	4
STD-1215	2-5-43	Bolt	1	STD-1727	5-1-20	Washer	1
STD-1215	3-4-27	Bolt	8	STD-1727	5-2-12	Washer	1
STD-1215	5-1-6	Bolt	2	STD-1727	5-2-25	Washer	1
STD-1221	2-6-24	Ring	1	STD-1727	5-2-28	Washer	2
STD-1227	2-3	Washer	2	STD-1763	6-2-5	Locknut	4
STD-1227	2-8-12	Washer	2	STD-1763	6-3-6	Locknut	4
STD-1269	3-4-22	Clamp	8	STD-1774	1-7-13	Pin	1
STD-1323	5-4-4	Bolt	1	STD-1774	2-5-3	Pin	1
STD-1339	2-3-3	Plug	1	STD-1774	2-5-30	Pin	1
STD-1339	2-5-28	Plug	1	STD-1774	2-7-5	Pin	1
STD-1339	2-5-29	Plug	1	STD-1791	1-4-12	Bolt	4
STD-1409	1-5-6	Nut	3	STD-1791	1-6-13	Bolt	4
STD-1409	2-3	Nut	2	STD-1817	5-1-7	Bolt	3
STD-1409	2-8-15	Nut	2	STD-1817	5-2-11	Bolt	2
STD-1410	1-6-18	Nut	1	STD-1817	5-2-15	Bolt	1
STD-1410	2-6-17	Nut	4	STD-1817	5-2-23	Bolt	2
STD-1410	2-7-8	Nut	4	STD-1817	5-2-38	Bolt	1
STD-1410	2-7-13	Nut	4	STD-1834	5-1-12	Bolt	1
STD-1410	2-7-18	Nut	4	STD-1835	5-1-13	Bolt	1
STD-1410	4-1-8	Nut	4	STD-1836	5-1-12	Bolt	1
STD-1410	5-4-5	Nut	3	STD-1836	5-2-5	Bolt	1
STD-1410	6-1-15	Nut	4	STD-1837	5-1-13	Bolt	1
STD-1410	6-1-20	Nut	4	STD-1837	5-2-6	Bolt	1
STD-1410	6-2-4	Nut	4	STD-1838	5-2-4	Bolt	4
STD-1410	6-3-5	Nut	4	STD-1838	5-2-45	Bolt	2
STD-1410	6-3-11	Nut	4	STD-1838	7-4-9	Bolt	1
STD-1410	7-2-5	Nut	8	STD-1851	5-2-5	Bolt	1
STD-1411	1-5-2	Nut	8	STD-1851	5-2-6	Bolt	1
STD-1411	1-5-3	Nut	2	STD-1856	2-4-7	Screw	4
STD-1411	1-5-3	Nut	1	STD-1856	2-4-22	Screw	3
STD-1411	2-4-19	Nut	1	STD-1858	5-2-23	Bolt	1
STD-1411	2-5-33	Nut	2	STD-1872	3-2-8	Insert	8
STD-1411	2-5-36	Nut	1	STD-1872	3-2-8	Insert	4
STD-1411	2-6-5	Nut	8	STD-1874	4-4	Screw	4
STD-1411	2-6-5	Nut	4	STD-1874	4-5	Screw	3
STD-1411	2-6-11	Nut	4	STD-1882	6-1-4	Screw	2
STD-1411	2-8-8	Nut	2	STD-1884	2-4-7	Screw	3
STD-1411	2-8-9	Nut	12	STD-1884	2-4-7	Screw	4
STD-1411	2-9-14	Nut	4	STD-1889	5-2-27	Bolt	2
STD-1411	2-9-14	Nut	10	STD-1897	6-3-19	Bolt	1
STD-1411	2-9-15	Nut	8	STD-1901	2-8-21	Drive Stud	4
STD-1411	3-3-18	Nut	4	STD-1901	2-9-20	Drive Stud	4
STD-1411	4-2-19	Nut	2	STD-1904	2-3	Bolt	2
STD-1411	4-3	Nut	2	STD-1916	4-4	Screw	1
STD-1411	4-4	Nut	1	STD-1919	1-2-5	Screw	6
STD-1411	5-1-8	Nut	1	STD-1924	3-4-18	Clamp	8
STD-1411	6-4	Nut	1	STD-1925	3-4-9	Screw	24
STD-1414	1-5-2	Bolt	8	STD-1925	4-4	Screw	3
STD-1414	2-3-11	Bolt	2	STD-1926	1-6-17	Bolt	3
STD-1416	1-5-6	Bolt	3	STD-1930	7-4-4	Hose	1
STD-1419	1-5-5	Bolt	3	STD-2032	6-1-3	Washer	2
STD-1420	2-3-8	Nut	3	STD-2033	5-2-6	Bolt	1
STD-1420	5-1-15	Nut	2	STD-2069	5-2-38	Bolt	1
STD-1420	5-2-8	Nut	2	STD-2072	2-5	"O" Ring	1
STD-1433	2-8-13	Bolt	2	STD-2084	1-5-3	Bolt	1
STD-1499	6-3-19	Bolt	1	STD-2084	1-5-3	Bolt	2
STD-1530	3-4-22	Clamp	8	STD-2084	5-1-5	Bolt	1
STD-1592	2-6-21	Bolt	2	STD-2090	1-5-10	Nut	2
STD-1592	6-1-9	Bolt	2	STD-2090	3-4-15	Nut	16

AVCO LYCOMING AIRCRAFT ENGINE GROUP ASSEMBLY PARTS LIST

O-320, IO-320, LIO-320 SERIES
 NUMERICAL INDEX PARTS SECTION

PART NO.	FIG-REF. NO.	PART NAME	QTY.	PART NO.	FIG-REF. NO.	PART NAME	QTY.
10-13799	4-4-17	Nut	6	31C-40	2-2-16	Stud	4
10-13799	4-5-20	Nut	1	38-13	1-1-5	Stud	16
10-32326	4-5-29	Spring	8	38-14	1-1-5	Stud	16
10-35936-6	4-5-9	Screw	8	38D-17	1-1-15	Stud	1
10-78916	4-4-18	Bracket	3	50-14	1-1-4	Stud	8
10-89027-4	4-5-21	Bracket	1	50-15	1-1-4	Stud	8
10-91431-8	4-4-16	Screw	6	50-16	1-1-4	Stud	8
10-91431-8	4-5-19	Screw	1	383-B	3-4-14	Nut	16
10-90404-4	4-5-10	Nut	8	1025-B	1-1-5	Stud	16
10-163007	4-4-20	Grommet	4	1028-B	1-2-10	Ball	1
10-163011	4-4-11	Ferrule	8	1691-C	2-6-13	Gasket	1
10-163011	4-5-22	Ferrule	8	1691-C	6-1	Gasket	1
10-163012	4-4-12	Eyelet	8	1691-C	6-1-11	Gasket	2
10-163012	4-5-23	Eyelet	8	1182-B3	4-7-2	Spark Plug	8
10-209328	4-4-13	Strap	7	1182-E3	4-7-2	Spark Plug	8
10-209328	4-5-26	Tie	5	1182-F3	4-7-2	Spark Plug	8
10-320050	4-5-16	Grommet	2	1182-F5	4-7-2	Spark Plug	8
10-320283	4-5-11	Clamp	8	1182-J5	4-7-2	Spark Plug	8
10-320297-1	4-4-24	Clamp	3	1182-L3	4-7-1	Spark Plug	8
10-320297-1	4-4-27	Clamp	1	1182-M4	4-7-2	Spark Plug	8
10-320297-2	4-5-12	Clamp	1	1182-N3	4-7-2	Spark Plug	8
10-320297-2	4-5-27	Clamp	1	1182-N4	4-7-2	Spark Plug	8
10-320297-3	4-4-21	Clamp	3	1182-P2	4-7-2	Spark Plug	8
10-320298-1	4-4-22	Clamp	3	1182-T4	4-7-2	Spark Plug	8
10-320298-1	4-5-13	Clamp	3	1182-U4	4-7-2	Spark Plug	8
10-320298-2	4-4-23	Clamp	2	1182-V1	4-7-1	Spark Plug	8
10-320298-2	4-5-15	Clamp	2	1182-X2	4-7-2	Spark Plug	8
10-320298-3	4-4-28	Clamp	1	8313	2-6-1	Gasket	1
10-320300-1	4-5-18	Clamp	1	8313	2-6-1	Gasket	2
10-320328	4-4-26	Bracket	3	8313	2-6-12	Gasket	1
10-320394	4-5-17	Plate	2	40239	4-2	Protector	4
10-320401	4-4-19	Plate	2	40239	4-3	Protector	4
10-320411	4-4-15	Screw	2	40239	4-4	Protector	4
10-320411	4-5-25	Screw	1	40239	4-5	Protector	4
10-320412-1	4-4-14	Clamp	2	45664	4-2-1	Cable	AR
10-320412-3	4-5-24	Clamp	1	45688	1-6-4	Flange	1
10-320471	4-4-25	Tubing	23.2	60009	3-3-9	Key	8
10-320471	4-5-14	Tubing	65.3	60028	3-2-4	Guide	4
10-320473	4-5-30	Sleeve	8	60053	3-3-19	Seal	8
10-320610-58	4-4-2	Lead	1	60096	2-6-18	Gasket	1
10-320610-59	4-4-6	Lead	1	60096	6-1-2	Gasket	1
10-320610-60	4-5-2	Lead	1	60096	6-1-7	Gasket	1
10-320610-68	4-5-7	Lead	1	60329	2-3-1	Shaft	1
10-320610-69	4-5-4	Lead	1	60398	3-4-3	Bushing	4
10-320610-72	4-4-1	Lead	1	60401	3-4-6	Shaft	4
10-320610-72	4-4-4	Lead	1	60430	2-6-2	Cover	1
10-320610-72	4-5-1	Lead	1	60430	2-6-2	Cover	2
10-320610-75	4-4-5	Lead	1	60430	2-6-7	Cover	1
10-320610-75	4-4-8	Lead	1	60431	2-6-14	Cover	1
10-320610-78	4-5-5	Lead	1	60431	6-1-17	Cover	1
10-320610-79	4-5-3	Lead	1	60670	4-2-6	Plate	2
10-320610-82	4-5-8	Lead	1	60733	5-1-9	Shim	AR
10-320610-87	4-4-7	Lead	1	60746	2-3-5	Impeller	1
10-320610-87	4-5-6	Lead	1	60747	2-3-6	Impeller	1
10-320610-91	4-4-3	Lead	1	60803	1-5-9	Strap	1
10-349224	4-4-10	Grommet	2	60820	2-8-10	Gasket	1
10-349661-1	4-4-9	Plate	2	60828	3-1-6	Plug	8
25C-10-P03	2-4-18	Stud	1	60882	1-6-2	Gear	1
31C-38	2-1-15	Stud	4	60886	5-4	Belt	1
31C-38	2-2-16	Stud	4	61098	2-5-2	Adapter	1
31CD-22	2-2-11	Stud	1	61155	1-3-9	Gear	1

AVCO LYCOMING AIRCRAFT ENGINE GROUP ASSEMBLY PARTS LIST

O-320, IO-320, LIO-320 SERIES
 NUMERICAL INDEX PARTS SECTION

PART NO.	FIG-REF: NO.	PART NAME	QTY.	PART NO.	FIG-REF. NO.	PART NAME	QTY.
61156	1-3-10	Lockplate	1	61668	2-1-7	Stud	2
61163	4-1-2	Gear	1	61668	2-1-8	Stud	2
61165	2-3-9	Seal	1	61668	2-2-7	Stud	2
61173	2-4-3	Gasket	1	61668	2-2-8	Stud	2
61174	2-3-4	Shaft	1	61850	2-9-8	Stud	4
61183	2-5-1	Gasket	1	62224	4-1-3	Gasket	3
61183	2-6-6	Gasket	1	62224	4-1-3	Gasket	4
61238	2-1-4	Stud	3	62224	4-1-3	Gasket	2
61238	2-1-5	Stud	1	62224	4-1-3	Gasket	1
61238	2-2-4	Stud	3	62254	6-5-4	Clip	4
61238	2-2-5	Stud	1	62281	7-3-4	Gage	1
61247	3-4-8	Cover	4	62388	3-3-11	Cap	4
61260	7-2-2	Flange	4	62415	2-4-26	Plunger	1
61261	1-1-10	Stud	2	62417	2-4-23	Plug	1
61261	2-1-6	Stud	2	62815	2-4-1	Housing	1
61261	2-1-7	Stud	2	62817	2-4-4	Screen	1
61261	2-1-8	Stud	2	62833	5-5	Regulator	1
61261	2-1-9	Stud	2	65007	1-1-9	Retainer	8
61261	2-2-6	Stud	2	65074	3-3-13	Socket	8
61261	2-2-7	Stud	2	65098	2-6-19	Cover	1
61261	2-2-8	Stud	2	65098	6-1-6	Cover	1
61261	2-2-9	Stud	2	65321	7-2-1	Gasket	4
61261	2-9-8	Stud	4	65441	3-3-5	Seat	4
61261	3-2-7	Stud	8	65441	3-3-6	Seat	4
61262	2-5-9	Stud	1	65567	3-3-3	Spring	8
61265	2-1-10	Stud	3	65819	1-4-2	Bushing	4
61265	2-2-10	Stud	2	66145	2-5-11	Dowel	2
61265	2-2-11	Stud	1	66224	6-2-1	Gasket	1
61358	2-8-19	Plug	1	66224	6-3-2	Gasket	1
61363	3-4-20	Pipe	2	66224	6-3-3	Gasket	1
61364	3-4-20	Pipe	1	66610	3-2-11	Bushing	16
61365	3-4-20	Pipe	1	66734	1-1-2	Stud	2
61376	2-8-3	Connection	2	66734	1-1-3	Stud	2
61377	2-8-4	Connection	2	66796-P10	3-2-6	Insert	8
61378	2-8-17	Screen	1	67447	1-2-1	Bearing	4
61381	2-8-11	Tube	1	67447	1-2-1	Bearing	8
61385	4-2-15	Clip	2	67453	1-1-12	Dowel	6
61385	4-3	Clip	2	67528	1-1-11	Stud	1
61387	1-1-21	Sleeve	1	67528	2-1-6	Stud	2
61400	2-1-2	Stud	2	67528	2-2-6	Stud	2
61400	2-2-2	Stud	2	67556	2-7-4	Stud	4
61400	2-9-6	Stud	4	68315	2-7-2	Gasket	1
61476-S	1-4-1	Conn. Rod	4	68316	2-7-4	Stud	4
61510	1-3-7	Plug	1	68316	6-3-8	Stud	4
61544	1-7-6	Plunger	1	68317	2-6-22	Shaftgear	1
61544	6-1-5	Plunger	1	68437	2-8-5	Stud	4
61546	4-2-4	Sleeve	12	68437	2-9-7	Stud	4
61548	2-8-20	Plate	1	68510	3-2-9	Stud	4
61548	2-9-19	Plate	1	68512	3-1	Ring	--
61559	4-2-9	Grommet	2	68513	3-1	Ring	--
61561	4-2-8	Plate	2	68517	3-3-16	Spring	8
61566	4-1	Kit	2	68518	3-3-17	Lockplate	4
61566	4-1	Kit	1	68532	7-4-1	Tube	1
61581-2	6-5-2	Tube Assy.	2	68593	2-6-8	Spacer	4
61581-3	6-5-3	Tube Assy.	1	68604	4-3	Clamp	4
61581-3	6-5-3	Tube Assy.	2	68604	7-4-2	Clip	2
61581-9	6-5-1	Tube Assy.	2	68626	5-5	Regulator	1
61665	4-1-2	Gear	1	68628	5-5	Relay	1
61665	4-1-2	Gear	2	68633	2-1-16	Shield	1
61666	4-1-4	Adapter	1	68639	1-4-9	Gear	1
61666	4-1-4	Adapter	2	68639	1-6-7	Gear	1

AVCO LYCOMING AIRCRAFT ENGINE GROUP ASSEMBLY PARTS LIST

O-320, IO-320, LIO-320 SERIES
 NUMERICAL INDEX PARTS SECTION

PART NO.	FIG-REF. NO.	PART NAME	QTY.	PART NO.	FIG-REF. NO.	PART NAME	QTY.
68668	1-2-11	Spring	1	69742	2-5-20	Cover	1
68749	1-6-15	Shaft	2	69796	1-1-12	Dowel	6
68753	1-6-10	Spacer	1	69796	1-1-12	Dowel	8
68757	1-6-8	Shaft	1	69796	1-1-12	Dowel	2
68759	3-4-19	Tube	1	69827	2-5-44	Gasket	1
68760	3-4-19	Tube	1	69942	2-5-23	Stud	2
68761	3-4-19	Tube	2	69942	2-5-24	Stud	1
68764	5-3-1	Generator	1	69943	2-1-5	Stud	1
68765	5-3-1	Generator	1	69943	2-2-5	Stud	1
68767	5-3-1	Generator	1	69951	5-1-16	Strut	1
68769	1-4-7	Camshaft	1	70310	3-3-20	Seal	8
68867	1-6-1	Support Assy.	1	70347	2-5-7	Dual Drive Assy.	1
68870	5-1-1	Bracket	1	70348	2-5-7	Dual Drive Assy.	1
68872	5-5	Regulator	1	70419	5-2-1	Bracket	1
68939	1-6-3	Spacer	1	70419	5-2-2	Bracket	1
68942	1-6-1	Support Assy.	1	70482	2-9-4	Connection	4
68972	2-8-1	Gasket	1	70484	2-9-16	Screen	1
68972	2-9-1	Gasket	1	71011	7-4-1	Tube	1
68974	2-4-1	Housing	1	71023	2-5-41	Brace	1
69106	2-7-9	Cover	1	71032	1-1-19	Bushing	8
69113	5-1-1	Bracket	1	71133	3-4-12	Nut	16
69116	7-3-5	Gage	1	71134	3-4-13	Nut	16
69159	1-7-12	Adapter	1	71140	2-4-34	Fitting	1
69164	1-7-11	Gasket	1	71349	5-5	Relay	1
69250	6-2-2	Carburetor	1	71350	5-5	Regulator	1
69260-P10	3-2-6	Insert	8	71397	4-1-1	Magneto	1
69316	2-5-14	Gear	1	71397	4-1-1	Magneto	2
69318	2-5-26	Shaft	1	71398	4-1-1	Magneto	1
69319	2-5-12	Gear	1	71432	4-1-1	Magneto	2
69320	2-5-39	Capscrew	3	71481	3-4-10	Ring	4
69335	2-9-18	Plug	1	71489	4-3-1	Plug	8
69345	3-3-15	Spacer	4	71551	7-3-6	Gage	1
69370	2-8-2	Sump	1	71556	3-1	Ring	--
69373	1-4-5	Bearing	8	71571	4-1	Kit	1
69376	1-1-6	Stud	2	71574	4-1	Kit	2
69377	1-1-2	Stud	2	71574	4-1	Kit	1
69377	1-1-3	Stud	2	71577	1-3-8	Tube	4
69436	2-4-25	Spring	1	71579	5-4	Belt	1
69444	3-4-2	Rocker	4	71594	3-1	Piston	--
69452	5-1-1	Bracket	1	71596	2-5-17	Washer	2
69457	3-1	Ring	--	71596	2-6-23	Washer	1
69510	2-4-2	Housing	1	71596	2-5-13	Washer	1
69531	3-4-11	Plate	7	71596	2-5-6	Washer	1
69531	3-4-11	Plate	8	71610	7-1-3	Hook	2
69532	3-3-8	Seat	4	71611	7-1-2	Retainer	2
69551	2-7-10	Gasket	1	71620	2-4-29	Bolt	1
69602	2-9-5	Connection	4	71621	7-4-2	Clip	2
69603	3-4-21	Hose	4	71621	7-4-6	Clip	1
69650	3-1-5	Pin	4	71622	7-4-1	Tube	1
69675	2-4-27	Connector	1	71623	2-4-32	Washer	1
69679	1-1-6	Stud	2	71646	1-6-16	Lockplate	2
69719	2-5-20	Cover	1	71714	1-2-14	Plug	1
69720	2-5-19	Gasket	1	71744	5-3-1	Generator	1
69722	2-5-25	Stud	1	71745	5-5	Regulator	1
69724	2-5-10	Stud	3	71824	4-3	Clamp	2
69725	2-5-8	Adapter	1	71840	3-1	Cylinder	--
69730	2-5-15	Gear	1	71841	3-1	Cylinder	--
69731	2-5-16	Bushing	1	71844	3-1	Cylinder	--
69737	2-5-45	Spacer	1	71909	6-5-5	Clamp	4
69740	2-1-4	Stud	3	71910	6-5-5	Clamp	4
69740	2-2-4	Stud	3	71913	4-2-12	Clamp	4

AVCO LYCOMING AIRCRAFT ENGINE GROUP ASSEMBLY PARTS LIST

O-320, IO-320, LIO-320 SERIES
 NUMERICAL INDEX PARTS SECTION

PART NO.	FIG-REF. NO.	PART NAME	QTY.	PART NO.	FIG-REF. NO.	PART NAME	QTY.
71913	4-3	Clamp	4	73117	2-2-15	Tube	1
71969	3-1	Cylinder	--	73136	6-4-14	Bracket	1
71973	3-4-24	Gasket	4	73149	3-1	Cylinder	--
71979	5-5	Regulator	1	73152	6-4-11	Bracket	1
71980	5-3-1	Generator	1	73231	2-5-18	Gear	1
72050	3-3-10	Seat	8	73245	4-2-3	Eyelet	8
72053	2-7-15	Gasket	1	73245	4-2-10	Eyelet	8
72057	3-2-2	Seat	4	73245	4-3-11	Eyelet	8
72058	3-2-3	Seat	4	73246	4-2-7	Kit	2
72063	1-3-5	Bushing	3	73346	3-4-23	Flange	4
72063	1-3-5	Bushing	5	73360	4-1-1	Magneto	1
72064	1-3-6	Bushing	2	73383	5-2-3	Lockplate	2
72065	1-3-4	Bushing	1	73383	5-2-44	Lockplate	1
72066	1-3-4	Bushing	1	73411	3-4-1	Rod	AR
72067	1-3-5	Bushing	5	73412	3-4-1	Rod	AR
72067	1-3-5	Bushing	3	73413	3-4-1	Rod	AR
72068	1-3-6	Bushing	2	73414	3-4-1	Rod	AR
72075	1-2-7	Seal	6	73650	6-4-4	Clip	4
72077	5-5	Regulator	1	73726	4-2-2	Lockclip	8
72078	1-4-11	Lockplate	2	73729	4-2	Cable & Plate	1
72078	1-6-12	Lockplate	2	73772	1-1-17	Nozzle Assy.	4
72079	1-4-10	Slinger	1	73796	6-4-2	Tube Assy.	2
72079	1-6-11	Slinger	1	73817	1-6-16	Lockplate	2
72091	1-2-8	Ring	2	73818	2-1	Gasket	1
72150	7-1-1	Baffle	2	73818	2-2	Gasket	1
72153	7-1-1	Baffle	2	73857	3-1	Ring	--
72198	3-1-6	Plug	8	73938	3-3-1	Valve	4
72205	5-5	Regulator	1	73952	1-2-4	Plate	1
72230	1-7-1	Shaft	1	73963	6-4-1	Tube Assy.	2
72231	1-7-4	Gear	1	73970	6-4-13	Hose	1
72311	5-5	Regulator	1	73971	6-4-12	Clamp	1
72312	7-3-3	Ring	1	73971	6-4-12	Clamp	2
72351	4-2-11	Screw	8	73972	2-1-1	Housing	1
72351	4-3	Screw	8	73974	6-4-13	Hose	1
72351	4-5-28	Screw	8	73998	3-1	Ring	--
72362	2-8-2	Sump	1	74059	3-1	Piston	--
72378	2-7-14	Cover	1	74065	7-3-3	Ring	1
72394	6-2-2	Carburetor	1	74068	7-3-3	Ring	1
72413	2-4-34	Fitting	1	74068	7-3-7	Ring	1
72453	4-3	Clamp	4	74070	7-4	Elbow	1
72454	3-1	Ring	--	74083	2-9-2	Sump	1
72495	4-1-2	Gear	1	74084	3-4-20	Pipe	4
72498	2-1-1	Housing	1	74151	6-3-13	Nozzle	4
72500	2-1-1	Housing	1	74167	1-4-7	Camshaft	1
72501	2-1-1	Housing	1	74207	6-3-7	Elbow	1
72502	2-1-1	Housing	1	74217	7-3	Ring	1
72503	2-1-1	Housing	1	74225	6-5-9	Nipple	4
72504	2-1-1	Housing	1	74230	3-2-5	Guide	4
72506	2-1-1	Housing	1	74241	3-1	Ring	--
72524	4-1-1	Magneto	1	74291	5-5	Regulator	1
72566	1-6-2	Gear	1	74292	5-5	Regulator	1
72569	7-1-1	Baffle	2	74314	7-3	Plug	1
72695	5-3-1	Generator	1	74323	5-1-17	Strut	1
72815	6-4-10	Bracket	1	74323	5-2-37	Strut	1
72829	1-7-2	Lockplate	1	74324	5-2-16	Bracket	1
72842	7-3	Plug	1	74325	5-1-19	Link	1
72847	7-3-5	Gage	1	74325	5-2-22	Link	1
72877	1-2-9	Body	8	74326	6-3-15	Bracket	1
72970	2-5-5	Gear	1	74327	3-4-11	Plate	1
73050	4-3	Clamp	1	74414	1-6-1	Support Assy.	1
73117	2-1-14	Tube	1	74468	3-1	Cylinder	--

AVCO LYCOMING AIRCRAFT ENGINE GROUP ASSEMBLY PARTS LIST

O-320, IO-320, LIO-320 SERIES
 NUMERICAL INDEX PARTS SECTION

PART NO.	FIG-REF. NO.	PART NAME	QTY.	PART NO.	FIG-REF. NO.	PART NAME	QTY.
74468	3-2-1	Cylinder	4	75302	1-1-7	Dowel	2
74494	3-4	Plate	4	75317	3-1	Cylinder	--
74513	2-9-3	Sump	1	75361	3-1	Cylinder	--
74515	2-1-1	Housing	1	75361	3-2-1	Cylinder	4
74519	5-4	Belt	1	75380	5-2-22	Link	1
74521	3-4-20	Pipe	2	75401	3-1	Kit	--
74522	3-4-20	Pipe	2	75403	3-1	Kit	--
74523	7-3-5	Gage	1	75413	3-1	Piston	--
74524	7-3	Ring	1	75505	6-1-22	Adapter	2
74532	6-4-13	Hose	1	75506	6-1-21	Kit	1
74534	6-3-1	Fuel Injector	1	75507	6-1-21	Kit	1
74541	3-3-2	Valve	4	75511	5-2-1	Bracket	1
74543	6-4-8	Hose	1	75512	5-2-2	Bracket	1
74554	3-3-6	Seat	4	75528	2-4-10	Kit	1
74586	6-4-8	Hose	1	75545	2-7-1	Adapter	1
74636	3-4-4	Rocker	4	75626	2-1-20	Plug	1
74637	3-4-5	Bushing	4	75626	2-2-18	Plug	1
74646	1-4-4	Nut	8	75686	6-1	Elbow	1
74661	5-5	Relay	1	75722	2-7-1	Adapter	1
74667	1-4-3	Bolt	8	75730	7-4-3	Tube	1
74673	3-1	Ring	--	75735	7-3-1	Tube	1
74732	6-4-8	Hose	1	75736	7-3-2	Tube	1
74804	5-5	Relay	1	75739	7-4	Nipple	1
74816	5-3-3	Pulley	1	75767	7-3-2	Tube	1
74842	6-3-12	Spacer	1	75772	3-3-14	Tube	8
74878	5-3-4	Fan & Baffle	1	75854	3-1	Cylinder	--
74989	3-1	Ring	--	75868	3-1	Cylinder	--
74996	1-7-7	Gear	1	75868	3-2-1	Cylinder	4
74996	1-7-7	Gear	2	75888	2-1-2	Stud	2
75009	6-3-15	Bracket	1	75888	2-1-3	Stud	4
75010	1-3-1	Crankshaft	1	75888	2-2-2	Stud	2
75011	1-3-1A	Crankshaft	1	75888	2-2-3	Stud	4
75012	1-3-1B	Crankshaft	1	75896	4-1-1	Magneto	1
75042	3-1	Cylinder	--	75897	4-1-1	Magneto	1
75042	3-2-1	Cylinder	4	75906	3-4-7	Gasket	4
75044	3-1	Cylinder	--	75907	3-1	Cylinder	--
75068	3-3-2	Valve	4	75907	3-2-1	Cylinder	4
75072	1-7-8	Gear	1	75919	2-1-1	Housing	1
75089	3-1	Piston	--	75920	6-1-16	Spacer	4
75135	6-1	Baffle	1	75924	1-7-10	Shaftgear	1
75153	2-7-1	Adapter	1	75941	4-3	Tape	1
75154	1-1-2	Stud	2	75944	2-4-8	Valve	1
75154	1-1-3	Stud	2	75965	4-1-5	Clamp	4
75155	1-1-6	Stud	2	76026	5-4	Belt	1
75156	1-1-16	Stud	1	76028	5-1-18	Link	1
75158	1-6-15	Shaft	2	76028	5-2-10	Link	1
75165	7-4-5	Clip	1	76075	4-3-12	Magneto Plate	2
75166	7-4-3	Tube	1	76081	3-3-2	Valve	4
75167	7-4-3	Tube	1	76082	6-3-1	Fuel Injector	1
75183	3-1	Cylinder	--	76086	3-1	Cylinder	--
75183	3-2-1	Cylinder	4	76086	3-2-1	Cylinder	4
75184	3-1	Cylinder	--	76097	1-4-6	Camshaft	1
75184	3-2-1	Cylinder	4	76098	1-4-6	Camshaft	1
75188	3-1	Cylinder	--	76103	2-2-1	Housing	1
75188	3-2-1	Cylinder	4	76104	2-2-1	Housing	1
75220	5-3-2	Alternator	1	76105	2-2-1	Housing	1
75246	6-1-1	Pump	1	76106	2-2-1	Housing	1
75247	6-1-1	Pump	1	76107	2-2-1	Housing	1
75251	6-4-8	Hose	1	76108	2-2-1	Housing	1
75252	6-4-9	Elbow	1	76110	2-2-1	Housing	1
75278	6-3-14	Manifold	1	76111	2-2-1	Housing	1

AVCO LYCOMING AIRCRAFT ENGINE GROUP ASSEMBLY PARTS LIST

O-320, IO-320, LIO-320 SERIES
 NUMERICAL INDEX PARTS SECTION

PART NO.	FIG-REF. NO.	PART NAME	QTY.	PART NO.	FIG-REF. NO.	PART NAME	QTY.
76112	2-2-1	Housing	1	77044	1-2-2	Bearing	1
76113	2-2-1	Housing	1	77260	6-3-1	Fuel Injector	1
76116	2-2-1	Housing	1	77279	6-2-2	Carburetor	1
76118	1-6-10	Spacer	1	77309	1-7-5	Bushing	1
76119	2-2	Shield	1	77309	1-7-9	Bushing	2
76121	1-6-8	Shaft	1	77377	1-2-3	Seal	1
76188	6-1-10	Pump	1	77462	3-1	Kit	--
76210	5-4-1	Starter	1	77476	3-1	Cylinder	--
76211	5-4-1	Starter	1	77526	7-3-2	Tube	1
76212	5-4-1	Starter	1	77543	6-3-1	Fuel Injector	1
76220	1-5-10	Bolt	2	77547	6-3-15	Bracket	1
76220	1-5-11	Bolt	2	77548	6-3-14	Manifold	1
76234	3-1	Kit	--	77597	6-3-1	Fuel Injector	1
76235	3-1	Kit	--	77718	5-2-14	Strut	1
76236	3-1	Kit	--	77742	4-1	Mag. & Harness	1
76239	3-1	Kit	--	77743	4-6	Harness Assy.	1
76273	5-1-2	Bracket	1	77744	4-1	Mag. & Harness	1
76299	2-9-3	Sump	1	77745	4-6	Harness Assy.	1
76354	2-3	Body	1	77756	5-2-16	Bracket	1
76449	3-1	Kit	--	77757	5-2-26	Bracket	1
76486	6-1-10	Pump	1	77808	1-2-16	Valve	1
76496	5-3-2	Alternator	1	77808	1-2-16	Valve	1
76500	3-1	Kit	--	77857	3-1-5	Pin	4
76510	2-4-9	Gasket	1	77907	1-5-10	Spacer	2
76517	6-4-8	Hose	1	77965	2-8-2	Sump	1
76529	1-2-15	Plug	1	77985	4-1-1	Magneto	1
76533	5-2-16	Bracket	1	78027	1-4-3	Bolt	8
76534	5-2-40	Shim	AR	78030-S	1-4-1	Conn. Rod	4
76628	1-6-1	Support Assy.	1	78059	5-5	Relay	1
76648	4-3-10	Grommet	2	78060	5-5	Relay	1
76658	3-1	Kit	--	78206	1-1	Crankcase	1
76659	3-1	Kit	--	78217	1-1	Crankcase	1
76691	2-4-11	Gasket	1	78220	1-1	Crankcase	1
76728	4-3-9	Sleeve	8	78221	1-1	Crankcase	1
76734	4-3	Zip Strap	6	78222	1-1	Crankcase	1
76734	4-6	Zip Strap	8	78223	1-1	Crankcase	1
76753	4-3-6	Sleeving Ring	4	78224	1-1	Crankcase	1
76754	4-3-7	Plate	2	78225	1-1	Crankcase	1
76755	4-3-2	Collar	8	78226	1-1	Crankcase	1
76757	4-3-3	Nut	8	78228	1-1	Crankcase	1
76768	5-2-35	Lockwasher	1	78290	3-3-12	Plunger	8
76769	5-2-36	Locknut	1	78292	4-1-3	Gasket	2
76773	5-4	Switch	1	78308	5-3-2	Alternator	1
76775	5-4	Switch	1	78310	5-3-2	Alternator	1
76818	5-2-22	Link	1	78312	5-3-2	Alternator	1
76852	4-3-10	Grommet	2	78314	5-3-2	Alternator	1
76853	4-3-12	Plate	2	78368	1-6-9	Pin	1
76899	1-6-1	Support Assy.	1	78401	5-3-2	Alternator	1
76906	5-2-16	Bracket	1	78403	5-3-2	Alternator	1
76908	5-2-37	Strut	1	78405	5-3-2	Alternator	1
76923	4-3-5	Cable	AR	78407	5-3-2	Alternator	1
76927	2-2-1	Housing	1	78409	5-3-2	Alternator	1
76940	1-2-3	Seal	1	78513	3-1	Kit	--
76944	1-6-1	Support Assy.	1	78515	3-1	Kit	--
76949	4-1-1	Magneto	1	78516	3-1	Kit	--
76950	4-1-1	Magneto	1	78539	4-3	Cable Assy.	1
76951	1-3-1D	Crankshaft	1	78540	4-3	Cable Assy.	1
76961	4-1	Clamp	4	78542	4-3	Cable Assy.	1
76994	3-3-4	Spring	8	78546	4-3	Cable Assy.	1
76999	1-3-1C	Crankshaft	1	78547	4-3	Cable Assy.	1
77034	1-2-1	Bearing	4	78614	5-2-32	Pulley	1

AVCO LYCOMING AIRCRAFT ENGINE GROUP ASSEMBLY PARTS LIST

O-320, IO-320, LIO-320 SERIES
 NUMERICAL INDEX PARTS SECTION

PART NO.	FIG-REF. NO.	PART NAME	QTY.	PART NO.	FIG-REF. NO.	PART NAME	QTY.
78616	7-3	Gage	1	LW-10496	1-3-1E	Crankshaft	1
78617	5-2-34	Idler Shaft	1	LW-10501	2-2-1	Accy. Housing	1
78626	7-3	Tube Assy.	1	LW-10518	4-1-1	Magneto	2
78629	5-2-33	Bearing	1	LW-10551	1-6-2	Gear	1
78639	5-2-31	Pulley & Shaft	1	LW-10552	1-6-1	Support Assy.	1
78728	6-2-2	Carburetor	1	LW-10556	5-4	Starter	1
78881	5-3	Extension Assy.	1	LW-10566	1-4-6	Camshaft	1
78955	4-1-1	Magneto	1	LW-10647	1-1-12	Dowel	4
5579983	2-4-16	Gasket	1	LW-10672	5-3-2	Alternator	1
6435683	2-4-15	Filter	1	LW-10729	5-2-22	Link	1
6436048	2-4-12	Nut	1	LW-10751	2-9-2	Sump	1
6436624	2-4-17	Stud	1	LW-10799	6-1-12	Spacer	1
6436636	2-4-13	Gasket	1	LW-11021	1-2-1	Bearing	4
6436638	2-4-14	Gasket	1	LW-11025	1-1	Crankcase	1
LW-10076	3-3-8	Seat	4	LW-11062	1-1	Crankcase	1
LW-10077	3-3-7	Seat	4	LW-11078	1-1	Crankcase	1
LW-10105	2-2-1	Housing	1	LW-11123	4-3	Spacer	8
LW-10124	1-2-1	Bearing	4	LW-11139	5-5	Regulator	1
LW-10179	5-5	Regulator	1	LW-11140	5-5	Regulator	1
LW-10185	5-5	Regulator	1	LW-11145	4-1-1	Magneto	1
LW-10372	5-3-2	Alternator	1	LW-11165	2-2-1	Accy. Housing	1
LW-10388	4-3-4	Elbow	2	LW-11166	6-1-10	Pump	1
LW-10389	4-3-4	Elbow	4	LW-11222	6-2-2	Carburetor	1
LW-10389	4-3-4	Elbow	8	LW-11237	1-1	Crankcase	1
LW-10389	4-3-4	Elbow	6	LW-11305	1-1	Crankcase	1
LW-10390	4-3-4	Elbow	4	LW-11357	5-5	Regulator	1
LW-10400	4-3-8	Ferrule	16	LW-11395	5-3-2	Alternator	1
LW-10475	6-3-13	Nozzle	4	LW-11396	5-3-2	Alternator	1
LW-10491	2-3	Body Assy.	1	LW-620326-2	4-5	Harness	1
				LW-620505-1	4-4	Harness	1

SUPPLEMENTAL PARTS LISTS

SUPPLEMENTAL PARTS LIST SSP2872

**TO PROVIDE PARTS COVERAGE FOR AVCO LYCOMING
MODEL O-320-D1F and O-320-E1F ENGINES**

This parts supplement is not arranged in the same format as PC-103, but it is based on the same page and reference numbers listed in PC-103.

The departure appears when O-320-D1F or E1F engine parts are referred to under a particular column on the original catalog page. Parts listed under that column are the same on both D1F and E1F engines unless otherwise specified.

Example: Parts on page 1-7 under column O-320-E2C are the same as on both O-320-D1F and O-320-E1F engines.

Only those parts which are different, new, or require a different quantity than in PC-103 are listed. Pages in the original parts catalog which do not apply to O-320-D1F or O-320-E1F engines are so designated.

O-320-D1F, -E1F WIDE CYLINDER
FLANGE AIRCRAFT ENGINES

SECTION 1

CRANKCASE, CRANKSHAFT AND CAMSHAFT

Ref. No.	Part Number	Description	Qty. Per Engine	Model Usage
Page 1-1				
	LW-11026	CRANKCASE ASSEMBLY	1	-D1F, -E1F
1	STD-557	DOWEL, Hollow, 1/2 in. dia. x 39/64 long	2	-D1F, -E1F
2	75154	STUD, 1/2-20 x 10-1/16 in. long	2	-D1F, -E1F
4	50-15	STUD, 1/2-20 x 1-7/8 in. long	8	-D1F, -E1F
5	38-13	STUD, 3/8-16 x 1-5/8 in. long	16	-D1F, -E1F
8	1102	PLUG, Allen Hd., 1/8-27 NPT	4	-D1F, -E1F
9	65007	RETAINER, Shroud Tube Seal	8	-D1F, -E1F
10	61261	STUD, 5/16-18 x 15/16 in. long	2	-D1F, -E1F
11	67528	STUD, 5/16-18 x 1-5/8 in. long	1	-D1F, -E1F
12	69796	DOWEL, Crankshaft Bearing	2	-D1F, -E1F
12	LW-10647	DOWEL, Crankshaft Bearing	4	-D1F, -E1F
13	STD-514	DOWEL, 5/16 in. dia. x 1/2 in. lg.	2	-D1F, -E1F
14	STD-1623	INSERT, Heli-Coil, 1/4-20 x 3/8 in. long	2	-D1F, -E1F
15	38D-17	STUD, Drilled, 3/8-16 x 2-1/8 in. long	1	-D1F, -E1F
16	75156	STUD, 5/16-18 x 15/16 in. long	1	-D1F, -E1F
	STD-1339	PLUG, Allen Hd., 1/16-27 NPT	1	-D1F, -E1F
	68316	STUD, 5/16-18 x 1-11/16 in. long	4	-D1F, -E1F
	67556*	STUD, 5/16-18 x 2.00 in. long	4	-D1F

Driven Height for P/N 68316 is .96 - 1.00 in.

Driven Height for P/N 67556 is 1.31 in.

* 38 model -D1F engines were manufactured with the 2 in. long stud.
Use only parts listed above for crankcase assembly.

Page 1-2				
1	LW-11021	BEARING, Crankshaft	4	-D1F, -E1F
2	77044	BEARING, Crankshaft, front	2	-D1F, -E1F
3	LW-11997	SEAL, Crankshaft oil	1	-D1F, -E1F
7	72075	SEAL, Oil, 0.090 in. section x 15/32 in. dia.	2	-D1F, -E1F
11	61084	SPRING, Oil pressure relief valve	1	-D1F, -E1F
15	76529	PLUG, Oil pressure relief valve	1	-D1F, -E1F

**O-320-D1F, -E1F WIDE CYLINDER
FLANGE AIRCRAFT ENGINES**

SECTION 1 (CONT.)

CRANKCASE, CRANKSHAFT AND CAMSHAFT

Ref. No.	Part Number	Description	Qty. Per Engine	Model Usage
-------------	----------------	-------------	--------------------	----------------

Page 1-2 (cont.)

For other parts applicable to O-320-D1F, -E1F model engines use figure reference numbers 8-9-10-12-13.

Page 1-3

For all parts on page 1-3 applicable to O-320-D1F, -E1F model engines use column under O-320-D1A (WCF) listings. Use illustration Ref. 1-B for prop. flange bushing locations.

Page 1-4

4	LW-12186	NUT, Connecting Rod	8	-D1F, -E1F
6	78717	CAMSHAFT	1	-D1F, -E1F

For other parts applicable to O-320-D1F, -E1F model engines use column under O-320-D1A.

Page 1-5

1	STD-33	WASHER, Plain, 3/8 in.	5	-D1F, -E1F
	AN960-616L	WASHER, Plain (Thick) 3/8 in.	AR	-D1F, -E1F
	AN6-34A	BOLT, Hex. Hd., 3/8-24 x 3-37/64 long	1	-D1F, -E1F
10	76220	STUD, 1/2-20 x 10-45/64 in. long	4	-D1F, -E1F

For other parts applicable to O-320-D1F, -E1F model engines use column under O-320-D1A (WCF).

Page 1-6

2	72566	GEAR, Starter Ring, 12/14 Pitch	1	-D1F, -E1F
---	-------	---------------------------------	---	------------

For other parts applicable to O-320-D1F, -E1F model engines use column under O-320-D2A except for those figure references marked "C" and 15-16-17.

Page 1-7

For all parts on this page applicable to O-320-D1F, -E1F model engines use column under O-320-D1A.

O-320-D1F, -E1F WIDE CYLINDER
FLANGE AIRCRAFT ENGINES

SECTION 2

ACCESSORY HOUSING AND DRIVES

Ref. No.	Part Number	Description	Qty. Per Engine	Model Usage
----------	-------------	-------------	-----------------	-------------

Page 2-1

Page 2-1 does not apply to O-320-D1F, -E1F model engines.

Page 2-2

For accessory housing P/N applicable to O-320-D1F, -E1F model engines, use column under O-320-D1A. For remaining parts use column under 76110.

Page 2-3

	78528	BODY ASSY., Oil pump	1	-D1F, -E1F
3	STD-1339	PLUG, 1/16-27 NPT allen hd.	1	-D1F, -E1F
4	75288	SHAFT, Oil pump drive	1	-D1F, -E1F
5	LW-12897	IMPELLER, Oil pump driving	1	-D1F, -E1F
6	78532	IMPELLER ASSY., Oil pump driven	1	-D1F, -E1F
7	STD-35	WASHER, 5/16 plain	3	-D1F, -E1F
8	STD-1420	NUT, 5/16-18 slotted	3	-D1F, -E1F
9	61165	SEAL, tachometer drive, oil	1	-D1F, -E1F
10	STD-8	WASHER, 1/4 plain	12	-D1F, -E1F
10	STD-1204	BOLT, 1/4-20 x 15/16 long, hex. hd.	10	-D1F, -E1F
11	STD-160	WASHER, 1/4 internal lock	12	-D1F, -E1F
11	STD-1414	BOLT, 1/4-20 x 1-1/2 long, hex. hd.	2	-D1F, -E1F
	STD-1973	KEY, 1/8 x 3/4 dia. Woodruff	1	-D1F, -E1F

Page 2-4

	STD-784	PLUG, 3/8 pipe, Allen	2	-D1F, -E1F
--	---------	-----------------------	---	------------

For other parts use O-320-E2D. Refs. 2, 3, 4, 5, 6, 7, 8, 27, 28 and 34.
Do not use Refs. 9 thru 22.

43 O-320-D1F engines were built with P/N 72413 (Ref. 34)

Page 2-5

Use column under O-320-D1A and:

	77875	GEAR, Propeller governor, driven	1	-D1F, -E1F
	77876	SHAFT, Prop. gov. idler gear	1	-D1F, -E1F
	77874	GEAR ASSY., Prop gov. idler	1	-D1F, -E1F
	STD-19	DOWEL, .0907 dia. x .22 long	1	-D1F, -E1F
	77872	BUSHING	1	-D1F, -E1F

O-320-D1F, -E1F WIDE CYLINDER
FLANGE AIRCRAFT ENGINES

SECTION 2 (CONT.)

ACCESSORY HOUSING AND DRIVES

Ref. No.	Part Number	Description	Qty. Per Engine	Model Usage
	STD-798	DOWEL, .09 dia. x .28 long	1	D1F, -E1F
	73249	WASHER, Thrust	AR	D1F, -E1F
	73250	WASHER, Thrust	AR	D1F, -E1F
	73251	WASHER, Thrust	AR	D1F, -E1F
	73252	WASHER, Thrust	AR	D1F, -E1F
	MS9048-111	PIN, Spring, 1/8 dia. x 1-3/8 long	1	D1F, -E1F
	70455	GASKET, .78 ID x 1-1/8 OD x .06 thick	1	D1F, -E1F
	70454	PLUG, 3/4-16 hex hd.	1	D1F, -E1F

Page 2-6

Use column under O-320-D1A, References 1 thru 5 only.

Page 2-7

Use column under O-320-D1A (WCF) References 9 thru 18 only. Do not use P/N STD-783.

Page 2-8

Page 2-8 does not apply to model O-320-D1F or O-320-E1F engines.

Page 2-9

2	LW-10828	SUMP ASSY., Oil	1	D1F, -E1F
4	78914	CONNECTION, Intake Pipe	4	D1F, -E1F
12	STD-1204	BOLT, Hex. hd. 1/4-20 x 15/16 lg.	14	D1F, -E1F
13	STD-8	WASHER, 1/4 plain	28	D1F, -E1F
14	STD-160	WASHER, 1/4 internal lock	20	D1F, -E1F
15	STD-1411	NUT, 1/4-20 plain	12	D1F, -E1F
	STD-1419	BOLT, 1/4-20 x 1-1/8 long, hex hd.	2	D1F, -E1F
18	LW-12545	PLUG, 5/8 x 1.00-20 thd., hex hd.	1	D1F, -E1F

For other parts use column under O-320-D1A.

SECTION 3

CYLINDER, PISTON, AND VALVE TRAIN

Page 3-1

1	75089	PISTON, 8.50:1	4	-D1F
---	-------	----------------	---	------

O-320-D1F, -E1F WIDE CYLINDER
FLANGE AIRCRAFT ENGINES

SECTION 3 (CONT.)

CYLINDER, PISTON, AND VALVE TRAIN

Ref. No.	Part Number	Description	Qty. Per Engine	Model Usage
Page 3-1 (Cont.)				
1	75413	PISTON, 7.00:1	4	-E1F
2	74241	RING, Piston, Compression	4	-D1F
3	74241	RING, Piston, Compression	4	-D1F
2	74989	RING, Piston, Compression	4	-E1F
3	74989	RING, Piston, Compression	4	-E1F
4	73857	RING, Piston, Oil Regulating, Expander	4	-D1F, -E1F
5	69650	PIN, Piston	4	-D1F
5	77857	PIN, Piston	4	-E1F
6	60828	PLUG, Piston pin	8	-D1F, -E1F

Use above parts only.

Page 3-2				
1	LW-12416	CYLINDER & HEAD ASSY., Nitrided	4	-D1F
1	LW-12417	CYLINDER & HEAD ASSY., Nitrided	4	-E1F
4	76943	GUIDE, Valve, Intake	4	-D1F, -E1F
5	77160	GUIDE, Valve, Exhaust	4	-D1F, -E1F
8	STD-1872	INSERT, 1/8-27 helicoil taper pipe thd.	8	-D1F
	1102	PLUG, 1/8-27 NPT, Allen	4	-D1F, -E1F

For other parts use column under O-320-D1A.

Page 3-3				
3	LW-11795	SPRING, Valve, Inner	8	-D1F, -E1F
4	LW-11800	SPRING, Valve, Outer	8	-D1F, -E1F
13	65074	SOCKET, Push Rod, hydraulic tappet	8	-D1F, -E1F
13	78524	SOCKET, Push Rod, hydraulic tappet	8	-D1F, -E1F
14	68987	TUBE, Push Rod, Shroud	8	-D1F, -E1F
16	LW-12273	SPRING, Shroud tube	8	-D1F, -E1F
17	LW-12272	LOCKPLATE	4	-D1F, -E1F
19	62922	SEAL, Shroud tube	8	-D1F, -E1F

For other parts on model O-320-D1F use O-320-D1A. For other parts on model O-320-E1F use O-320-E1A but do not use Ref. 15.

O-320-D1F, -E1F WIDE CYLINDER
FLANGE AIRCRAFT ENGINES

SECTION 3 (CONT.)

CYLINDER, PISTON, AND VALVE TRAIN

Ref. No.	Part Number	Description	Qty. Per Engine	Model Usage
Page 3-4				
15	STD-2090	NUT, 1/2-20 plain	18	-D1F, -E1F
	74887	SPACER, 33/64 ID x 7/8 OD x 7/8 thick	2	-D1F, -E1F

For other parts use O-320-D1A (WCF) only.

SECTION 4

IGNITION SYSTEM

Page 4-1				
1	LW-349305-1	MAGNETO, S4LN-1209	1	-D1F, -E1F
1	LW-349365-3	MAGNETO, Impulse coupling (S4LN-1227)	1	-D1F, -E1F
3	LW-12681	GASKET, Magneto	2	-D1F, -E1F

For other parts use magneto P/N 75897. Do not use Reference 3.

Page 4-2

Does not apply.

Page 4-3

	LW-10811	TERMINALS, Spark Plug Wire	8	-D1F, -E1F
	LW-10814	SPRING, Spark Plug Terminal	8	-D1F, -E1F
2	LW-10812	COLLAR (Silicone) Spark Plug Terminal	8	-D1F, -E1F
	STD-8	WASHER, Plain, 1/4 in.	8	-D1F, -E1F
	STD-160	WASHER, Internal Lock, 1/4 in.	4	-D1F, -E1F
	AN500-416-12	SCREW, 1/4-20 x 3/4 in. long	4	-D1F, -E1F
	STD-696	WASHER, Plain, Thin	AR	-D1F, -E1F

For all other parts except those listed above, use column under O-320-D2C. Do not use P/N 76753.

Pages 4-4, 4-5, 4-6 Do not apply

O-320-D1F, -E1F WIDE CYLINDER
FLANGE AIRCRAFT ENGINES

SECTION 4 (CONT.)

IGNITION SYSTEM

Ref. No.	Part Number	Description	Qty. Per Engine	Model Usage
		Page 4-7		
1	1182-B3	SPARK PLUG	8	-D1F
1	1182-B6	SPARK PLUG	8	-E1F

Use above parts only.

SECTION 5

ELECTRICAL SYSTEM

Page 5-1
Does not apply.

Page 5-2
Use column O-320-D2A References 16 thru 45 only.

Page 5-3				
78308		ALTERNATOR, 12 volt-40 amp	1	-D1F, -E1F
78407*		ALTERNATOR, 12 volt-40 amp	1	-D1F

* 15 O-320-D1F engines were built equipped with this alternator. Use the above parts only.

Page 5-4				
4	STD-2156	BOLT, 5/16-18 x 1-5/32 long, hex hd.	1	-D1F, -E1F
	LW-12083	SWITCH, Magnetic, 12 volt	1	-D1F, -E1F

For all other parts use column O-320-E2B.

Page 5-5				
LW-10185		REGULATOR, 12 volt	1	-D1F, -E1F
78059		OVERVOLTAGE RELAY, 12 volt	1	-D1F, -E1F

SECTION 6

FUEL INDUCTION SYSTEM

Page 6-1
Use O-320-A2A Refs. 1 thru 4 only.

O-320-D1F, -E1F WIDE CYLINDER
FLANGE AIRCRAFT ENGINES

SECTION 6

FUEL INDUCTION SYSTEM

Ref. No.	Part Number	Description	Qty. Per Engine	Model Usage
Page 6-1 Use O-320-A2A Refs. 1 thru 4 only.				
Page 6-2				
2	78728	CARBURETOR, Model MA-4SPA Marvel-Schebler 10-5009-WCF For other parts use O-320-A2A	1	-D1F, -E1F
Pages 6-3, 6-4, 6-5 - Do not apply.				

SECTION 7

COOLING BAFFLES, EXHAUST, AND OIL GAGE

Page 7-1 Use O-320-E2D				
Page 7-2 Use O-320-D2C				
Page 7-3				
2	75767	TUBE, Oil level gage, intermediate	1	-D1F
2	75736	TUBE, Oil level gage, long	1	-E1F
	72059	GASKET, Oil level gage	1	-D1F, -E1F
3	74065	RING, Oil level gage seal	1	-D1F
3	74068	RING, Oil level gage seal	1	-E1F
5	72847	GAGE ASSY., Oil level	1	-D1F
5	69116	GAGE ASSY., Oil level	1	-E1F

Use above parts only.

Page 7-4
Does not apply.

SERVICE REPLACEMENT SETS
MODEL O-320-D1F AND O-320-E1F ENGINES

SEAL AND GASKET SET

PART NO.	DESCRIPTION	QTY. PER ENGINE
72053	GASKET, Governor drive	2
8313	GASKET, Vacuum pump	2
62922	SEAL, Shroud tube	8
60096	GASKET, Fuel pump	1
71973	GASKET, Intake flange	4
60592	GASKET, Carburetor	1
LW-11997	SEAL, Crankshaft oil	1
60820	GASKET, Oil suction tube flange	1
74068	RING, Oil level gage seal	1
61165	SEAL, Tachometer shaft	1
61173	GASKET, Oil pressure housing	1
61183	GASKET, Accessory adapter	1
75906	GASKET, Rocker box cover	4
73818	GASKET, Accessory housing	1
68972	GASKET, Oil sump	1
61531	GASKET, Hydraulic valve	1
62224	GASKET, Magneto adapter	4
65321	GASKET, Exhaust flange	4
66224	GASKET, Carburetor	1
71481	SEAL, Oil	4
68315	GASKET, Accessory drive adapter	1
70310	SEAL, Shroud tube	8
STD-208	SEAL, Oil	1
STD-294	GASKET, Annular	2
72075	SEAL, Oil	6
72091	RING, Oil seal	2
STD-1045	GASKET, Annular	2
61523	CONTAINER	1
69551	GASKET, Accessory pad cover	1
69720	GASKET, Dual Accessory drive cover	1
69827	GASKET, Governor spacer	1
STD-548	SEAL, Oil	1
66224	GASKET, Carburetor	1
74065	RING, Oil level gage seal	1
61156	LOCKPLATE, Crankshaft gear	1
76501	GASKET	1
72059	GASKET	1
69345	SPACER	4
LW-12273	SPRING	4
72078	LOCKPLATE, Camshaft gear	2

SEAL AND GASKET SET (CONT.)

PART NO.	DESCRIPTION	QTY. PER ENGINE
73817	LOCKPLATE, Crankshaft idler gear shaft	2
LW-12272	LOCKPLATE, Shroud tube	4
LW-12795	GASKET	1
STD-111	GASKET	1
STD-213	SEAL	1
1691-C	GASKET	1
69164	GASKET	1
71646	LOCKPLATE	2
72312	RING, Oil seal	1
73383	LOCKPLATE	2
74524	RING, Oil seal	1
LW-12681	MAGNETO GASKET	2

CYLINDER, PISTON, AND RING ASSEMBLY KIT

O-320-D1F ENGINES

HIGH COMPRESSION CHROME CYLINDER SET

SET #76239

MS-13997-3	KEY, Valve, exhaust	2
MS-13998-3	CAP, Valve stem	1
STD-1411	NUT, 1/4-20 plain	1
STD-1925	SCREW, 1/4-20 x 5/8 long, Fill hd., self lock	6
60009	KEY, Valve	2
62922	SEAL, Shroud tube	2
60401	SHAFT, Valve rocker	1
61247	COVER, Rocker box	1
LW-11800	SPRING, Valve Outer	2
65441	SEAT, Valve spring, lower	1
LW-11795	SPRING, Valve, Auxiliary	2
LW-10077	SEAT, Valve spring	1
LW-12273	SPRING, Shroud tube	1
LW-12272	LOCKPLATE, Shroud tube	1
69345	SPACER, Shroud tube spring	1
69444	ROCKER ASSY., Valve, intake	1
69650	PIN, Piston	1
70310	SEAL, Shroud tube	2
71195	BOX, Set up	1
71481	RING, Oil seal, .09 dia. sect. x 4.84 ID	1
72198	PLUG, Piston pin (Alum. bronze)	2
LW-10076	SEAT, Valve spring	1

SET #76239 (CONT.)

PART NO.	DESCRIPTION	QTY. PER ENGINE
73938	VALVE, Intake	1
73998*	RING, Piston, Oil regulating	1
74541	VALVE, Exhaust (rotator type)	1
74554	SEAT, Valve spring, lower, exhaust	1
74636	ROCKER ASSY., Valve, exhaust	1
74673*	RING, Piston, compression	2
75089	PISTON	1
75906	GASKET, Rocker box cover	1
LW-12419	CYLINDER AND HEAD ASSY.	1
STD-1215	BOLT	2
60828	PLUG, Piston pin (Alum.)	2
SSP-2472	TAG	1

* - Half Wedge Rings

O-320-D1F High Compression Nitrided Cylinder Set
SET #75401

73857*	RING, Oil regulating, expander type	1
74241*	RING, Piston, compression	2
LW-12416	CYLINDER AND HEAD ASSY.	1

All other parts are the same as in set #76239, but do not use P/N 72198-Piston Pin Plug.

* - Half Wedge Rings

O-320-E1F Low Compression Steel Cylinder Sets
SET #76659

68710	PIN, Piston	1
73857*	RING, Oil regulating	1
75068	VALVE, Exhaust (Rotator type)	1
74989*	RING, Piston, compression	2
75413	PISTON	1
LW-12417	CYLINDER AND HEAD ASSY.	1

All other parts are the same as in set #76239, but do not use P/N 72198-Piston Pin Plug.

* - Half Wedge Rings

SET #76659 - A

77857	PIN, Piston (Heavy)	1
73857*	RING, Oil Regulating	1
75068	VALVE, Exhaust (Rotator type)	1
74989*	RING, Piston, Compression	2
75413	PISTON	1

SET #76659 - A (CONT.)

PART NO.	DESCRIPTION	QTY. PER ENGINE
LW-12417	CYLINDER AND HEAD ASSY.	1
All other parts are the same as in set #76239, but do not use P/N 72198-Piston Pin Plug.		
* - Half Wedge Rings		

O-320-E1F Low Compression Chrome Cylinder Sets
SET #78513

68710	PIN, Piston	1
75068	VALVE, Exhaust (rotator type)	1
75413	PISTON	1

SET #78513-A

77857	PIN, Piston (heavy)	1
75068	VALVE, Exhaust (rotator type)	1
75413	PISTON	1
All other parts are the same as in set #76239, but do not use P/N 72198-Piston Pin Plug.		

SUPPLEMENTAL PARTS LIST

**To provide parts coverage for Model
O-320-E3D Avco Lycoming Aircraft Engines**

This parts list is arranged in the same basic format as Parts Catalog PC-103. Page numbers here correspond to page numbers in PC-103. Reference numbers here correspond to reference numbers in PC-103.

Where reference numbers listed in PC-103 are not used in this parts list it indicates those references are not applicable to O-320-E3D engines. Where parts are listed in this parts list without reference numbers it indicates those parts are not illustrated in PC-103.

Use all parts, but only those parts listed in this parts list for model O-320-E3D engines.

Where the notation "use column O-320-E2D" for a particular page appears (eg. : Page 1-7), all parts applicable to O-320-E2D engines also apply to O-320-E3D engines.

Where pages in PC-103 are not applicable to model O-320-E3D engines they are so designated.

SECTION 1

CRANKCASE, CRANKSHAFT AND CAMSHAFT

Page 1-1

Ref. No.	Part No.	Description	Qty. Per Engine
	LW-11062	CRANKCASE ASSY.	1
1	STD-557	DOWEL, 1/2 dia. x .60 long, hollow	2
2	75154	STUD, 1/2-13 x 10-1/32 long	2
4	50-15	STUD, 1/2-20 x 1-7/8 long	8
5	38-13	STUD, 3/8-16 x 1-5/8 long	16
8	1102	PLUG, 1/8-27 NPT, allen	5
9	65007	RETAINER, Shroud tube seal	6
10	61261	STUD, 5/16-18 x 15/16 long	1
11	67528	STUD, 5/16-18 x 1-5/8 long	1
12	69796	DOWEL, Crankshaft bearing	8
13	STD-514	DOWEL, 5/16 dia. x 1/2 long	2
14	STD-1623	INSERT, 1/4-20 heli-coil x 3/8 long	2
15	38D-17	STUD, 3/8-16 x 2-1/8 long, drilled	1
16	75156	STUD, 5/16-18 x 15/16 long	1

Page 1-2

1	67447	BEARING, Crankshaft	8
3	LW-11997	SEAL, Crankshaft, oil	1
7	72075	SEAL, Oil, 3/32 sect. x 15/32 ID	2
8	72091	RING, Oil seal, 23/64 ID x 3/32 dia.	2
9	72877	BODY, Hydraulic tappet	8
10	1028-B	BALL, 11/16 dia.	1
11	61084	SPRING, Oil pressure relief valve	1
12	STD-425	WASHER, No. 10 plain (max. 9)	AR
13	STD-1045	GASKET, 1-1/4 ID x 1-1/2 OD x 3/32 annular	1
15	76529	PLUG, Oil relief valve	1

Page 1-3

1	75010*	CRANKSHAFT ASSY.	1
1	LW-10496*	CRANKSHAFT ASSY.	1
1	LW-11854**	CRANKSHAFT ASSY.	1
4	72065*	BUSHING, Prop. flange	1

* - On some Piper applications.

** - On Beech and some Piper applications.

Page 1-3 (Cont.)

Ref. No.	Part No.	Description	Qty. Per Engine
4	72063*	BUSHING, Prop. flange	3
4	72066**	BUSHING, Prop. flange	1
5	72067**	BUSHING, Prop. flange	5
6	72064*	BUSHING, Prop. flange	2
7	61510*	PLUG, 1-9/16 dia.	1
9	61155	GEAR, Crankshaft	1
10	61156	LOCKPLATE, Crankshaft gear	1
11	STD-847	SCREW, 5/16-24 x 1.00 long	1

* - On some Piper applications.

** - On Beech and some Piper applications.

Page 1-4

1	78030	ROD ASSY., Connecting	4
2	65819	BUSHING, Connecting rod upper	4
3	78027	BOLT, Connecting rod	8
4	LW-12186	NUT, Connecting rod	8
5	69373	BEARING, Connecting rod	8
6	76097	CAMSHAFT	1

Page 1-5

1	AN6-34A	BOLT, 3/8-24 x 3-37/64 long	2
1	STD-33	WASHER, 3/8 plain	2
1	STD-33*	WASHER, 3/8 plain	6
1	STD-678**	WASHER, 3/8 internal lock	2
1	STD-596**	NUT, 3/8-24 plain	2
2	STD-1414	BOLT, 1/4-20 x 1-1/2 long, hex. hd.	8
2	STD-8	WASHER, 1/4 plain	16
2	STD-160	WASHER, 1/4 internal lock	8
2	STD-1411	NUT, 1/4-20 plain	8
3	STD-2084	BOLT, 1/4-20 x 1-3/4 long	1
3	STD-160	WASHER, 1/4 internal lock	1
3	STD-1411	NUT, 1/4-20 plain	1
5	STD-1419	BOLT, 1/4-20 x 1-1/8 long	3
5	STD-8	WASHER, 1/4 plain	3
5	STD-160	WASHER, 1/4 internal lock	3

* - Piper applications only.

** - Beech applications only.

Page 1-5 (Cont.)

Ref. No.	Part No.	Description	Qty. Per Engine
6	STD-1416	BOLT, 1/4-20 x 1-1/2 long	3
6	STD-8	WASHER, 1/4 plain	AR
6	STD-1409	NUT, 1/4-20 slotted shear	3
8	STD-872	NUT, 3/8-24 slotted	1
8	STD-33	WASHER, 3/8 plain	3
	AN960-616L	WASHER, 3/8 plain, thick (max. 3)	AR
9	60803	STRAP, Lifting	1
10	LW-11866*	SPACER NUT, Compressor	2
11	76220	STUD, 1/2-20 x 10.70 long	4

* - Piper applications only.

Page 1-6

1	68867*	SUPPORT ASSY., Starter ring gear 10/12 pitch, 1.91:1 drive	1
1	76944*	SUPPORT ASSY., Starter ring gear 10/12 pitch, 3.25:1 drive	1
1	76628**	SUPPORT ASSY., Starter ring gear 12/14 pitch	1
2	60882*	GEAR, Starter ring, 10/12 pitch	1
2	72566**	GEAR, Starter ring, 12/14 pitch	1
8	76121	SHAFT ASSY., Tachometer	1
9	78368	PIN, 3/16 dia. x 2.33 long	1
10	76118	SPACER, Tachometer shaft centering	1
14	MS16625-1081	RING, Internal retaining	1
15	75158	SHAFT, Crankshaft idler gear	2
16	71646	LOCKPLATE, 5/16 bolt x 1-3/4 spacing	2
17	STD-1926	BOLT, 5/16-18 x 43/64 long, hex. hd.	3
18	STD-1410	NUT, 5/16-18 plain	1

* - On some Piper applications.

** - Beech applications only.

Page 1-7

Use column O-320-E2D.

SECTION 2

ACCESSORY HOUSING AND DRIVES

Page 2-1

Not applicable.

Page 2-2

Use column O-320-E2D.

Page 2-3

Ref. No.	Part No.	Description	Qty. Per Engine
	78528	BODY ASSY., Oil pump	1
3	STD-1339	PLUG, 1/16-27 NPT, allen	1
4	75288	SHAFT, Oil pump drive	1
5	LW-12897	IMPELLER, Oil pump driving	1
6	78532	IMPELLER ASSY., Oil pump driven	1
7	STD-35	WASHER, 5/16 plain	3
8	STD-1420	NUT, 5/16-18 slotted	3
9	61165	SEAL, Tachometer drive, oil	1
10	STD-8	WASHER, 1/4 plain	12
10	STD-160	WASHER, 1/4 internal lock	12
10	STD-1204	BOLT, 1/4-20 x 15/16 long, hex. hd.	10
11	STD-1414	BOLT, 1/4-20 x 1-1/2 long, hex. hd.	2
	STD-1973	KEY, 1/8 x 3/4 dia. woodruff	1

Page 2-4

2	69510	HOUSING, Thermostatic valve and oil pressure screen	1
3	61173	GASKET, Oil pressure housing	1
4	62817	SCREEN ASSY., Oil pressure	1
5	STD-294	GASKET, 7/8 OD x 5/8 ID x 3/32 annular	1
6	STD-8	WASHER, 1/4 plain	4
7	STD-1856	SCREW, 1/4-20 x 31/32-1.00 long, hex. hd., slotted	4
8	75944	VALVE ASSY., Temp. control oil cooler bypass	1
23	62417*	PLUG, Oil cooler bypass	1

* - Piper applications only.

Page 2-4 (Cont.)

Ref. No.	Part No.	Description	Qty. Per Engine
24	STD-294*	GASKET, 7/8 OD x 5/8 ID x 3/32 annular	1
29	71620	BOLT, Oil cooler fitting	1
30	AN901-8A	GASKET, Metal tube connecting seal	1
31	AN777-8D	ELBOW, Universal, 75°	1
32	71623	WASHER, Oil cooler fitting	1
33	AN844-10D*	ELBOW, Pipe thd. and 5/8 ID hose, 45°	1
34	72413	FITTING, Breather, 120°	1

* - Piper applications only.

Page 2-5

Use column O-320-E2D.

Page 2-6

Use O-320-E2D references 1 thru 5 only on Piper applications.
Use O-320-E2D references 6 thru 11 only on Beech applications.

Page 2-7

Not applicable.

Page 2-8

Not applicable.

Page 2-9

1	68972	GASKET, Oil sump	1
2	LW-10828	SUMP ASSY., Oil	1
4	78914	CONNECTION, Intake pipe	4
6	61400	STUD, 1/4-20 x 1-3/16 long	4
7	68437	STUD, 5/16-18 x 1-7/8 long	4
9	STD-551	PLUG, 1/2-14 NPT, sq. hd., drilled	2
10	STD-91	PLUG, 1/2-14 NPT, allen	1
12	STD-8	WASHER, 1/4 plain	8
12	STD-160	WASHER, 1/4 internal lock	8
14	STD-160	WASHER, 1/4 internal lock	4
15	STD-1204	BOLT, 1/4-20 x 15/16 long, hex. hd.	14
15	STD-8	WASHER, 1/4 plain	20

Ref. No.	Part No.	Description	Qty. Per Engine
15	STD-160	WASHER, 1/4 internal lock	8
15	STD-1411	NUT, 1/4-20 plain	12
	STD-1419	BOLT, 1/4-20 x 1-1/8 long, hex. hd.	2
16	70484	SCREEN, Oil suction	1
17	STD-11	GASKET, 1.00 ID x 1-1/4 OD x 3/32 annular	1
18	LW-12545	PLUG, 5/8 hex. hd. x 1.00-20 thd.	1
19	61548	PLATE, Name	1
20	STD-1901	DRIVE STUD, No. 4 x 3/16 long, rd. hd.	4

SECTION 3

CYLINDER, PISTON AND VALVE TRAIN

Page 3-1

Ref. No.	Part No.	Description	Qty. Per Engine
1	75413	PISTON, 7.00:1 ratio	4
2	77857	PIN, Piston	4
3	60828	PLUG, Piston pin	8
4	74989	RING, Piston, compression	8
5	73857	RING, Piston, oil regulating, expander	4

Page 3-2

1	LW-12417	CYLINDER AND HEAD ASSY.	4
2	72057	SEAT, Intake valve	4
3	72058	SEAT, Exhaust valve	4
4	76943	GUIDE, Intake valve	4
5	77160	GUIDE, Exhaust valve	4
6	66796	INSERT, Spark plug, 18-1.5 MM	8
7	61261	STUD, 5/16-18 x 1-1/2 long	8
9	68510	STUD, 1/4-20 x 1-1/16 long	4
10	AN823-6D	ELBOW, 3/8 flared tube coupling, 45°	4
11	66610	BUSHING, Rocker shaft	16
	1102*	PLUG, 1/8-27 NPT, allen	4

* - On Beech and some Piper applications.

Ref. No.	Part No.	Description	Qty. Per Engine
1	73938	VALVE, Intake	4
2	75068	VALVE, Exhaust, rotator	4
3	LW-11795	SPRING, Valve, inner	8
4	LW-11800	SPRING, Valve, outer	8
5	65441	SEAT, Valve spring, lower, intake	4
6	74554	SEAT, Valve spring, lower, exhaust	4
7	LW-10077	SEAT, Valve spring, upper, intake	4
8	LW-10076	SEAT, Valve spring, upper, exhaust	4
9	60009	KEY, Valve, intake	8
10	MS13997-3	KEY, Valve, exhaust, rotator	8
11	MS13998-3	CAP, Valve stem, exhaust, rotator	4
12	78290	PLUNGER ASSY., Hydraulic tappet	8
13	78524	SOCKET, Push rod, hydraulic tappet	8
14	68987	TUBE, Push rod, shroud	8
16	LW-13428	SPRING, Shroud tube	4
17	LW-12272	LOCKPLATE, Shroud tube	4
18	STD-1411	NUT, 1/4-20 plain	4
19	62922	SEAL, Shroud tube	8
20	70310	SEAL, Shroud tube	8

Use column O-320-E2D and

15	STD-2090	NUT, 1/2-20 plain	18
	74887	SPACER, 33/64 ID x 7/8 OD 3/8 thick	2

SECTION 4

IGNITION SYSTEM

Ref. No.	Part No.	Description	Qty. Per Engine
	77742	MAGNETO AND HARNESS ASSY., Right	1
1	76949	MAGNETO, Right (Slick model 4050)	1
	77744	MAGNETO AND HARNESS ASSY., Left	1
1	76950	MAGNETO, Left (Slick model 4051 - impulse coupling)	1

Page 4-1 (Cont.)

Ref. No.	Part No.	Description	Qty. Per Engine
2	61665	GEAR, Magneto, impulse coupling	1
	STD-761	COTTER PIN	1
2	61163	GEAR, Magneto	1
3	62224	GASKET, Magneto adapter and magneto	1
4	LW-12706	ADAPTER, Magneto impulse coupling	1
	LW-12681	GASKET, Magneto	2
5	76961	CLAMP, Magneto	4
6	STD-1727	WASHER, Plain, 3/4 OD x 11/32 ID x 1/8 thick	4
7	STD-475	WASHER, 5/16 internal lock	4
8	STD-1410	NUT, 5/16-18 plain	4
	76734	ZIP STRAPS	8

Page 4-2

Not applicable.

Page 4-3

Not applicable.

Page 4-4

Not applicable.

Page 4-5

Not applicable.

Page 4-6

Use column O-320-E2D.

Page 4-7

1	1182-B6	SPARK PLUG, Champion EM41E	8
---	---------	----------------------------	---

SECTION 5

ELECTRICAL SYSTEM

Page 5-1

Not applicable.

Page 5-2

Ref. No.	Part No.	Description	Qty. Per Engine
-------------	----------	-------------	--------------------

Use column O-320-E2D and the following on Beech applications only.

38	STD-1858	BOLT, 5/16-18 x 29/32 long, hex. hd. dr.	1
----	----------	--	---

The following parts apply to Piper O-320-E3D engines which were equipped with alternators, alternator brackets and attaching parts at Avco Lycoming.

LW-13039	BRACKET, Alternator	1
73383	LOCKPLATE, 5/16 bolt x 1.00 spacing	1
STD-1838	BOLT, 5/16-18 x 15/16 long, hex. hd.	2
75380	LINK, Alternator belt adjusting	1
STD-35	WASHER, 5/16 plain	1
STD-1817	BOLT, 5/16-18 x 3/4 long, hex. hd., dr.	2
STD-1727	WASHER, Plain, 3/4 OD x 11/32 ID x 1/8 thick	1
74323	STRUT, Alternator support	1
STD-1817	BOLT, 5/16-18 x 3/4 long, hex. hd., dr.	1
STD-33	WASHER, 3/8 plain	1
AN6-14	BOLT, 3/8-24 x 1-37/64 long, hex. hd., dr. end	1
STD-33	WASHER, 3/8 plain	AR
STD-872	NUT, 3/8-24, slotted	1
STD-713	COTTER PIN	1
AN6-13	BOLT, 3/8-24 x 1-29/64 long, hex. hd., dr. end	1
76534	SHIM, 1-1/8 OD x 13/32 ID x .005 thick	AR
STD-33	WASHER, 3/8 plain	AR
STD-872	NUT, 3/8-24 slotted	1
STD-713	COTTER PIN	1

Page 5-3

Not applicable.

Ref. No.	Part No.	Description	Qty. Per Engine
1	76210	STARTER, 12 volt, 10/12 pitch	1
1	76211*	STARTER, 12 volt, 12/14 pitch	1
2	STD-35	WASHER, 5/16 plain	4
3	STD-475	WASHER, 5/16 internal lock	4
4	LW-31-1.09	BOLT, 5/16-18 x 1-3/32 long, hex. hd.	1
4	STD-2156*	BOLT, 5/16-18	1
5	STD-1410	NUT, 5/16-18 plain	1

* - Beech applications only.

Not applicable.

SECTION 6

FUEL INDUCTION SYSTEM

Use references 1 thru 5 only.

Ref. No.	Part No.	Description	Qty. Per Engine
1	66224	GASKET, Carburetor	1
2	72394*	CARBURETOR, (10-3678-32)	1
2	78728	CARBURETOR, (10-5009)	1
3	STD-35	WASHER, 5/16 plain	4
4	STD-1410	NUT, 5/16-18 plain	4
5	STD-1763	LOCKNUT, 5/16 palnut	4

* - Beech applications.

Not applicable.

Page 6-4

Not applicable.

Page 6-5

Piper Applications

Ref. No.	Part No.	Description	Qty. Per Engine
	1102	PLUG, 1/8-27 NPT, allen	4
Beech Applications			
1	61581-9	TUBE ASSY., Primer, 16-11/16 long, cyls. 1 and 2	2
2	61581-2	TUBE ASSY., Primer, 11-11/16 long, cyls. 3 and 4	2
3	61581-3	TUBE ASSY., Primer, 10-5/16 long, intermediate	2
4	62254	CLIP, 3/16 ID for 1/4 dia. screw	4
5	71910	CLAMP, 1-3/4 ID with 1/4 dia. offset	4
6	STD-553	SCREW, No. 6-32 x 1/2 long, rd. hd.	4
7	AN365-632C	NUT, No. 6-32, self lock	4
8	STD-853	TEE, Union, 1/8 tube	3
9	74225	NIPPLE ASSY., Primer	4

SECTION 7

COOLING BAFFLES, EXHAUST, OIL GAGE
AND PROPELLER GOVERNOR OIL LINE

Page 7-1

Use column O-320-E2D.

Page 7-2

Ref. No.	Part No.	Description	Qty. Per Engine
1	65321*	GASKET, Exhaust flange	4
1	77611**	GASKET, Exhaust flange	4
2	STD-35	WASHER, 5/16 plain	8
3	STD-475	WASHER, 5/16 internal lock	8
4	STD-1410	NUT, 5/16-18 plain	8

* - Piper applications.

** - Beech applications.

Page 7-3
Piper Applications

Ref. No.	Part No.	Description	Qty. Per Engine
2	75736	TUBE, Oil level gage, long	1
	72059	GASKET, Oil level gage	1
3	74068	RING, Oil level gage	1
5	69116	GAGE ASSY., Oil level	1
7	72842	PLUG, Oil level gage	1
	STD-366	PIN, 1/16 dia. x 7/16 long	1

Beech Applications

	72059	GASKET, Oil level gage	1
	LW-12789	TUBE ASSY., Oil level gage, 12-13/16 long	1
	75767	TUBE, Oil level gage	1
	77527	EXTENSION, Oil filler	1
	72312	RING, Oil seal, 1.00 ID x 1/8 section	1
	LW-12791	GAGE ASSY., Oil level	1
	STD-406	DOWEL, 3/16 dia. x 1/2 long	2
	74217	RING, Plug, oil level gage	1
	74524	RING, Oil level gage bushing	1

Page 7-4

Not applicable.

SUPPLEMENTAL PARTS LIST NO. SSP 2771

To provide parts coverage for Avco Lycoming
IO-320-D1B MODEL ENGINES.

This parts supplement is not necessarily arranged in the same basic format as the original publication PC-103. However, it is arranged to provide parts coverage by using the same page as listed in the basic catalog. The departure, therefore, appears when IO-320-D1B engine parts are referred to a particular column on the basic catalog page. For example: The piston assembly for IO-320-D1B model engines may be referred to as under column headed by IO-320-D1A. This means that all parts listed under this heading also apply to IO-320-D1B model engines and the only listings present in the supplement will be those parts that are different, new or parts that require a different quantity per engine assembly. Any pages listed in the basic catalog, PC-103, not applicable to the IO-320-D1B model engine, will be so designated in this supplement.

AVCO LYCOMING AIRCRAFT ENGINE GROUP ASSEMBLY PARTS LIST

IO-320-D1B MODEL ENGINES
SECTION 1
CRANKCASE, CRANKSHAFT AND CAMSHAFT

REF. NO.	PART NUMBER	1	2	3	4	5	DESCRIPTION	QTY. PER ENG.	MODEL USAGE
----------	-------------	---	---	---	---	---	-------------	---------------	-------------

Page 1-1

	LW-11026						CRANKCASE ASSEMBLY	1	
4	50-15						STUD, 1/2-20 x 1-7/8 in. long	8	
5	38-13						STUD, 3/8-16 x 1-5/8 in. long	16	
	38-22						STUD, 3/8-16 x 2-3/4 in. long	1	
	72158						BUSHING, Gov. drive idler shaft	1	
8	1102						PLUG, Allen, 1/8-27 NPT	5	
	STD-1339						PLUG, Allen, 1/16-27 NPT	1	
	68316						STUD, 5/16-18 x 1-11/16 in. long (Driven height of studs 0.96-1.00 in. for crankcase service assembly)	4	

For all other parts applicable to IO-320-D1B use column under IO-320-C1A except figure reference numbers 6, 7, 17 and 18.

Page 1-2

2	77044						BEARING, Crankshaft front	2	
7	72075						SEAL, Oil, 0.090 in. section x 0.47 in. ID	2	

For all other parts applicable to IO-320-D1B use column under IO-320-C1A except figure reference numbers 3**, 4**, 5** and 6**, 14 and 16 do not apply.

Page 1-3

Use column under IO-320-D1A for IO-320-D1B model engines.

Page 1-4

Figure references No. 1, P/N 61476-S and No. 3, P/N 74667 do not apply to IO-320-D1B model engines.

6	78717						CAMSHAFT ASSEMBLY	1	
---	-------	--	--	--	--	--	-------------------	---	--

NOTE

Figure reference numbers 7 thru 12 do not apply to IO-320-D1B model engines.

Page 1-5

1	AN6-34A						BOLT, Hex. hd., 3/8-24 x 3-37/64 in. long	1	
1	STD-33						WASHER, Plain, 3/8 in.	2	
2	STD-8						WASHER, Plain, 1/4 in.	19	
2	STD-160						WASHER, Internal lock, 1/4 in.	12	
2	STD-1411						NUT, Plain, 1/4-20	9	
7	AN960-616L						WASHER, Plain, 3/8 in. (thick). Max. 3 pcs.	AR	
10	76220						STUD, 1/2-20 x 10-45/64 in. long	4	

For other crankcase attaching parts except those listed above, use column headed IO-320-D1A. Item 10 does not apply to IO-320-D1B model engines.

AVCO LYCOMING AIRCRAFT ENGINE GROUP ASSEMBLY PARTS LIST

IO-320-D1B MODEL ENGINES
SECTION 1 (CONT.)
CRANKCASE, CRANKSHAFT AND CAMSHAFT

REF. NO.	PART NUMBER	DESCRIPTION					QTY. PER ENG.	MODEL USAGE
		1	2	3	4	5		

Page 1-6

NOTE

Figure reference numbers 3 thru 13 do not apply to IO-320-D1B model engines.

Use column headed IO-320-D1A for all other parts listed on Page 1-6.

Page 1-7

Figure reference numbers 6 thru 9 and listed in column headed IO-320-D1A are the only parts listed on Page 1-7 applicable to IO-320-D1B model engines.

SECTION 2

ACCESSORY HOUSING AND DRIVES

Page 2-2

Use column headed IO-320-D1A for IO-320-D1B model engines.

Page 2-3

	78528	BODY ASSEMBLY, Oil pump					1	
3	STD-1339	PLUG, Allen hd., 1/16-27 NPT					1	
	78532	IMPELLER ASSEMBLY, Oil pump driven					1	
1	78530	SHAFT, Oil pump idler					1	
6	77272	IMPELLER, Oil pump driven					1	
4	75288	SHAFT, Oil pump drive					1	
5	77313	IMPELLER, Oil pump driving					1	
	STD-1973	KEY, Woodruff, 1/8 x 3/4 dia.					1	
8	STD-35	WASHER, Plain, 5/16 in.					3	
8	STD-1420	NUT, Slotted, 5/16-18					3	
9	61165	SEAL, Tachometer drive, oil					1	
10	STD-8	WASHER, Plain, 1/4 in.					12	
10	STD-160	WASHER, Internal lock, 1/4 in.					12	
10	STD-1204	BOLT, Hex. hd., 1/4-20 x 15/16 in. long					10	
11	STD-1414	BOLT, Hex. hd., 1/4-20 x 1-1/2 in. long					2	

Page 2-4

8	LW-10269	VALVE ASSEMBLY, Temp. control oil cooler by-pass					1	
---	----------	--	--	--	--	--	---	--

NOTE

Figure reference numbers 10 thru 22 do not apply to IO-320-D1B model engines as shipped from the factory.

For all other parts applicable to IO-320-D1B model engines listed on Page 2-4 use column headed IO-320-D1A.

Page 2-5

Use column headed IO-320-D1A for IO-320-D1B model engines.

AVCO LYCOMING AIRCRAFT ENGINE GROUP ASSEMBLY PARTS LIST

IO-320-D1B MODEL ENGINES
SECTION 2 (CONT.)
ACCESSORY HOUSING AND DRIVES

REF. NO.	PART NUMBER	DESCRIPTION					QTY. PER ENG.	MODEL USAGE
		1	2	3	4	5		

Page 2-6

Use column headed IO-320-D1A for IO-320-B1B model engines.

NOTE

Figure reference numbers 6 thru 17 on Page 2-6 do not apply to IO-320-D1B model engines as shipped from the factory.

77875	GEAR, Propeller governor driven	1
77876	SHAFT, Propeller gov. idler gear	1
77874	GEAR ASSEMBLY, Prop. gov. idler	1
77872	BUSHING, Prop. gov. idler gear	2
STD-19	DOWEL, 0.0907 dia. x 7/32 in. long	1
STD-798	DOWEL, 0.09 dia. x 9/32 in. long	1
73249	WASHER, Thrust	AR
73250	WASHER, Thrust	AR
73251	WASHER, Thrust	AR
73252	WASHER, Thrust	AR
MS9048-111	PIN, Spring, 1/8 in. dia. x 1-3/8 in. long	1
70455	GASKET, 7/8 in. ID x 1-1/8 OD x 1/16 in. thick	1
70454	PLUG, 3/4 in. hex. hd., -16 thread	1

Page 2-7

Figure reference numbers 1 thru 8 are not applicable to IO-320-D1B model engines. Use all figure reference numbers 9 thru 18 on IO-320-D1B model engines, if required.

Page 2-8

This page does not apply to IO-320-D1B model engines.

Page 2-9

2	LW-10830	SUMP ASSEMBLY, Oil	1
4	78914	CONNECTION, Intake pipe	4
12	STD-1204	BOLT, Hex. hd., 1/4-20 x 15/16 in. long	14
	STD-1419	BOLT, Hex. hd., 1/4-20 x 1-1/8 in. long	2

For all other parts listed on Page 2-9, which are applicable to IO-320-D1B model engines, use column headed IO-320-D1A.

SECTION 3

CYLINDER, PISTON AND VALVE TRAIN

Page 3-1

Use all columns opposite first listing of cylinder assembly, P/N 75042-N for IO-320-D1B model engines. On illustration page use light piston pin, P/N 69650, and P/N 60828 piston pin plug for IO-320-D1B model engines.

AVCO LYCOMING AIRCRAFT ENGINE GROUP ASSEMBLY PARTS LIST

IO-320-D1B MODEL ENGINES
SECTION 3 (CONT.)
CYLINDER, PISTON AND VALVE TRAIN

REF. NO.	PART NUMBER	DESCRIPTION					QTY. PER ENG.	MODEL USAGE
		1	2	3	4	5		

Page 3-2

	68510					STUD, 1/4-20 x 1-1/16 in. long	4	
--	-------	--	--	--	--	--------------------------------	---	--

For all other cylinder assembly parts, except that listed above, use column headed by IO-320-D1A for IO-320-D1B model engines.

Page 3-3

3	LW-11795					SPRING, Valve, inner	8	
4	LW-11800					SPRING, Valve, outer	8	
13	78524					SOCKET, Push rod, hydraulic tappet	8	
14	68987					TUBE, Push rod shroud	8	
19	62922					SEAL, Shroud tube	8	

For all other related valve parts use column headed IO-320-D1A for IO-320-D1B model engines.

Page 3-4

	74887					SPACER, 33/64 ID x 7/8 OD x 3/8 in. thick	2	
15	STD-2090					NUT, Plain, 1/2-20	18	

For all other related push rod and intake pipe parts use column headed IO-320-D1A for IO-320-D1B model engines.

SECTION 4

IGNITION SYSTEM

Page 4-1

1	75896					MAGNETO, S4LN-1209	1	
	75897					MAGNETO, S4LN-1227, Impulse coupling	1	

For all magneto related parts use column headed P/N 75897 for IO-320-D1B model engines.

Page 4-2

This page does not apply to IO-320-D1B model engines.

Page 4-3

	78546					IGNITION HARNESS, 1200 series mags., straight valve head	1	
--	-------	--	--	--	--	--	---	--

For related ignition harness parts use column headed IO-320-D1A for IO-320-D1B model engines.

NOTE

Following is a complete listing of harness attaching parts, which differs somewhat from basic catalog.

AVCO LYCOMING AIRCRAFT ENGINE GROUP ASSEMBLY PARTS LIST

IO-320-D1B MODEL ENGINES
SECTION 4 (CONT.)
IGNITION SYSTEM

REF. NO.	PART NUMBER	DESCRIPTION					QTY. PER ENG.	MODEL USAGE
		1	2	3	4	5		
		Page 4-3 (cont.)						
	76734						6	
	68604						2	
	71824						2	
	73050						1	
	STD-8						8	
	40239						4	
	STD-160						4	
	AN500-416-12						4	
	STD-696						AR	

Page 4-4 thru 4-6

These pages do not apply to IO-320-D1B model engines.

Page 4-7

Use column headed IO-320-D1A for IO-320-D1B model engines.

SECTION 5

ELECTRICAL SYSTEM

Page 5-1

This page does not apply to IO-320-D1B model engines.

Page 5-2

NOTE

Figure reference numbers 1 thru 15 do not apply to IO-320-D1B model engines. For figure reference numbers 16 thru 45 use column headed IO-320-D1A for IO-320-D1B model engines.

Page 5-3

2	78403	ALTERNATOR ASSEMBLY, 12v-50 amp., 3.25:1 ratio	1
---	-------	--	---

Page 5-4

	76026	BELT, Alternator drive, 3/8 in.	1
1	76211	STARTER, 12 volt, 12/14 pitch, 3.38:1, internal reduction	1
	LW-12083	SWITCH, Magnetic	1

For all other parts except those listed above, use column headed IO-320-D1A for IO-320-D1B model engines.

Page 5-5

	LW-10185	REGULATOR, 12 volt, full transistor	1
	78059	RELAY, Overvoltage, 12 volt	1

AVCO LYCOMING AIRCRAFT ENGINE GROUP ASSEMBLY PARTS LIST

IO-320-D1B MODEL ENGINES
SECTION 6
FUEL INDUCTION SYSTEM

REF. NO.	PART NUMBER	DESCRIPTION					QTY. PER ENG.	MODEL USAGE
		1	2	3	4	5		
Page 6-1								
1	60096	GASKET, Fuel pump					1	
2	75247	FUEL PUMP, Dual diaphragm					1	
3	STD-33	WASHER, Plain, 3/8 in.					2	
4	STD-1882	SCREW, Socket hd., drilled hd., 3/8-16 x 1-9/32 long					2	
5	75686	ELBOW, 5/16 in. tubing, 9/16-18 adjustable 90° (Assemble aft approx. 25° above centerline of fuel pump inlet)					1	

NOTE

Parts listed above on Page 6-1 are only parts applicable to IO-320-D1B model engines.

Page 6-2

This page does not apply to IO-320-D1B model engines.

Page 6-3

Use column under IO-320-D1A for IO-320-D1B model engines.

Page 6-4

1	LW-12098-200	TUBE ASSEMBLY, Fuel manifold to nozzle, Cyl. No. 1 and 3 (20 in. long)					2	
2	LW-12098-1-134	TUBE ASSEMBLY, Fuel manifold to nozzle, Cyl. No. 2 and 4					2	
3	72036	CLIP, 3/4 in. ID for 3/16 in. screw					4	
5	STD-860	SCREW, Fill. hd., #10-32 x 5/8 in. long					6	
7	STD-670	NUT, Self-locking, #10-32					6	
	LW-12145	CLIP, 1/8 in. ID for #10 screw					2	
	73136	BRACKET, 90°					2	

For all other fuel injector plumbing, except those parts listed above, use column listed under IO-320-D1A for IO-320-D1B model engines.

Page 6-5

1102		PLUG, Allen head, 1/8-27 NPT					4	
------	--	------------------------------	--	--	--	--	---	--

SECTION 7

COOLING BAFFLES, EXHAUST, OIL GAGE
AND PROP. GOVERNOR OIL LINE

Page 7-1

Use column under IO-320-D1A for IO-320-D1B model engines.

Page 7-2

Use column under IO-320-D1A model engines for IO-320-D1B model engines.

AVCO LYCOMING AIRCRAFT ENGINE GROUP ASSEMBLY PARTS LIST

IO-320-D1B MODEL ENGINES
SECTION 7 (CONT.)
COOLING BAFFLES, EXHAUST, OIL GAGE
AND PROP. GOVERNOR OIL LINE

REF. NO.	PART NUMBER	1	2	3	4	5	DESCRIPTION	QTY. PER ENG.	MODEL USAGE
-------------	----------------	---	---	---	---	---	-------------	---------------------	----------------

Page 7-3

Use column under IO-320-D1A model engines for
IO-320-D1B model engines.

Page 7-4

Page 7-4 is not applicable to IO-320-D1B model engines.



AVCO LYCOMING WILLIAMSPORT DIVISION
AVCO CORPORATION
WILLIAMSPORT, PENNSYLVANIA 17701

SUPPLEMENTAL PARTS LIST SSP975

To Provide Parts Coverage for Avco Lycoming
AEIO-320 Series Aircraft Engines

This parts supplement contains the parts that are used in place of, or in addition to the parts listed in Parts Catalog PC-103 for the comparable IO-320 model.

Those parts which set apart the AEIO-320 models from their comparable IO-320 models are the accessory housing, oil sump and associated fittings. Following is a list of these parts.

Part No.	Description	Qty.	Model Application
LW-14009	ACCESSORY HSG. ASSY.	1	AEIO-320-E1B
LW-14047	ACCESSORY HSG. ASSY.	1	AEIO-320-E2B
STD-551	PLUG, 1/2-14 NPT	1	
LW-13863	SUMP ASSY., Oil	1	
LW-13871	FITTING, Sump - oil suction	1	
AN932-5	PLUG, 1/2-14 allen hd.	1	
LW-13753	FITTING, Sump oil strainer	1	
LW-13754	FITTING, Sump oil return	1	
LW-13749	OIL SEPARATOR	1	
LW-13755	BREATHER TEE	1	
LW-13750	OIL VALVE	1	

SUPPLEMENTAL PARTS LIST

To Provide Parts Coverage for Model
O-320-E2G Avco Lycoming Aircraft Engines

This supplemental parts list is written to provide an engine parts comparison between the O-320-E2D as listed in Avco Lycoming PC-103, and engine model O-320-E2G. It is written to follow PC-103 page by page and part by part. Figure reference numbers, part numbers and page numbers follow exact construction of PC-103. Where necessary, because of numerous changes, all parts applicable to O-320-E2G model engines are listed.

If a part number in this supplement does not have a figure reference number, it denotes a new part, or a part not figure referenced in PC-103, or parts that are peculiar to O-320-E2G model engines. If a page in PC-103 is not applicable to O-320-E2G model engines, it is so designated in this supplement.

NOTICE

The spark plugs listed herein, are those used in current production only; this listing does not include additional spark plugs that are approved for use in these engines. See latest edition of Service Instruction No. 1042 for complete listing of all spark plugs.

O-320-E2G

SECTION 1
CRANKCASE ASSEMBLY

Page 1-1

Ref. No.	Part No.	Description	Qty. Per Assy.
	LW-13812	CRANKCASE ASSEMBLY	1
2	75154	STUD, 1/2-13 x 10.02 in. long	2
4	50-15	STUD, 1/2-13 x 1-7/8 in. long	8
5	38-13	STUD, 3/8-16 x 1-5/8 in. long	16
8	STD-1102	PLUG, Allen head, 1/8-27 NPT	5
9	65007	RETAINER, Shroud tube seal	8
10	61261	STUD, 5/16-18 x 1-1/2 in. long	2
11	67528	STUD, 5/16-18 x 1-5/8 in. long	1
12	69796	DOWEL, Crankshaft bearing	8
13	STD-514	DOWEL, 5/16 in. dia. x 1/2 in. long	2
14	STD-1623	INSERT, Heli-coil, 1/4-20 x 3/8 long	2
15	38D-17	STUD, 3/8-16 x 2-1/8 in. drilled	1
16	LW-13793	STUD, 5/16-18 x 15/16 in. drilled	1

Parts listed above comprise crankcase assembly for O-320-E2G model engines. O-320-E2G model engines have #1 dynafocal mounting.

Page 1-2

1	67447*	BEARING, Crankshaft	8
	68763	BEARING, Crankshaft (alternate)	8
3	LW-13792	SEAL, Crankshaft, oil	1
7	72075	SEAL, Oil, .090 in. section x 15/32 in. ID	2
8	72091	RING, Oil seal, 23/64 in. ID x 7/64 in. dia.	2
11	61084	SPRING, Oil pressure relief valve	1

For all other parts, except for those listed above, for O-320-E2G model engines, use figure reference numbers 9, 10, 12, 13 and 15.

Page 1-3

Use column headed O-320-E2D for all parts necessary for O-320-E2G.

Page 1-4

1	78030	ROD ASSEMBLY, Connecting	4
2	LW-13923	BUSHING, Connecting rod, upper	4
3	78027	BOLT, Connecting rod	8
4	LW-12186	NUT, Connecting rod bolt	8
5	69373	BEARING, Connecting rod	8
6	76097	CAMSHAFT	1

Use only above listed parts for O-320-E2G model engines.

O-320-E2G

SECTION 1 (CONT.)
CRANKCASE ASSEMBLY

Page 1-5

Ref. No.	Part No.	Description	Qty. Per Assy.
1	AN6-34A	BOLT,Hex.hd.,3/8-24 x 3-37/64 in.long	2

For all other parts, except that listed above,use column headed -E2D for O-320-E2G model engines. Do not use STD-2090 nut or 77907 spacer.

Page 1-6

15	LW-13796	SHAFT,Crankshaft idler gear	2
17	STD-2167	SCREW,Hex.hd.,drilled,5/16-18 x 7/8 in.long	3
18	STD-2168	NUT,Slotted shear,5/16-18 NC-3	1

For all other parts,except those listed above,use column under -E2D marked "with integral camshaft and gear" and "WCF".

Page 1-7

For all parts applicable to O-320-E2G model engines,use column headed -E2D.

SECTION 2
ACCESSORY HOUSING AND DRIVES

Page 2-1

This page is not applicable to O-320-E2G model engines.

Page 2-2

For all parts applicable to O-320-E2G model engines use columns headed -B2B and 76103. Stud P/N 61238, 4 pcs. on O-320-E2G.

Page 2-3

	78528	BODY ASSEMBLY,Oil pump	1
	78532	IMPELLER ASSY.,Oil pump driven	1
	STD-1339	PLUG	1
	61174	SHAFT,Oil pump drive	1
9	LW-14260	SEAL,Tachometer drive,oil	1
10	STD-8	WASHER,Plain,1/4 in.	12
10	STD-160	WASHER,Internal lock,1/4 in.	12

Do not use figure reference numbers 2 and 6 but all other figure reference numbers under column headed -E2D except those listed above are applicable to O-320-E2G model engines.

O-320-E2G

SECTION 2 (CONT.)
ACCESSORY HOUSING AND DRIVES

Page 2-4

Ref. No.	Part No.	Description	Qty. Per Assy.
	STD-784	PLUG, Allen hd., 3/8 in.	2

Figure reference numbers 9 thru 26 and 34 are not applicable to -E2G model engines. For all other parts, except that listed above, use column headed -E2D.

Page 2-5

For all parts applicable to O-320-E2G model engines, use column headed -E2D.

Page 2-6

Only figure reference numbers 1-2-3-4-5 under column headed -E2D are applicable to O-320-E2G model engines.

Page 2-7

For all parts applicable to O-320-E2G model engines, use column headed -E2D.

Page 2-8

This page is not applicable to O-320-E2G model engines.

Page 2-9

1	LW-13353	GASKET, Oil sump	1
2	72362	SUMP ASSEMBLY, Oil	1
4	61376	CONNECTION, Intake pipe, front	2
5	61377	CONNECTION, Intake pipe, rear	2
	68437	STUD, 5/16-18 x 1-7/8 in. long	4
9	STD-551	PLUG, Sq. hd., drilled, 1/2-14 NPT	1
15	STD-1411	NUT, Plain, 1/4-20	14
	STD-1419	BOLT, Hex. hd., 1/4-20 x 1-1/8 in. long	2
	60820	GASKET, Oil suction tube flange	1
	61381	TUBE ASSEMBLY, Oil suction	1
	STD-1227	WASHER, Plain, copper, 1/4 in.	2
	STD-1433	BOLT, Drilled end, hex. hd., 1/4-20 x 1-1/2 in. long	2
	STD-8	WASHER, Plain, 1/4 in.	Max. 4
	STD-1409	NUT, Slotted shear, 1/4-20	2
	STD-1204	BOLT, 1/4-20 x .94 long, hex. hd.	16

O-320-E2G

SECTION 2 (CONT.)
ACCESSORY HOUSING AND DRIVES

Page 2-9 (Cont.)

Ref. No.	Part No.	Description	Qty. Per Assy.
	STD-68	PIN, Cotter, 1/16 in. dia. x 1/2 in. long	2
	61378	SCREEN, Oil suction	1
	STD-1045	GASKET, Annular, 1/8 in. ID x 1-1/2 in. OD x 3/32 thick	1
	61358	PLUG, .150 hex. hd., x 1-1/4-12 thd.	1

SECTION 3
CYLINDER, PISTON AND VALVE TRAIN

NOTE

See actual catalog page for proper cylinder and piston parts for O-320-E2G model engines.

Page 3-1

1	75413	PISTON, Compression ratio 7.00:1	4
	74989	RING, Piston, top compression	8
	73857	RING, Piston, oil regulating	4
5	LW-14068	PIN, Piston	4
6	60828	PLUG, Piston pin	8

Page 3-2

1	LW-12417	CYLINDER ASSY., Plain	4
4	76943	GUIDE, Valve, intake	4
5	77160	GUIDE, Valve, exhaust	4
9	68510	STUD, 1/4-20 x 1-1/16 in. long	4
10	MS20823-6D	ELBOW, Flared tube coupling, 3/8 in. 45°	4

For all other parts applicable to O-320-E2G model engines, use column headed -E2D.

Page 3-3

2	74541	VALVE, Exhaust, rotator type (1/2 in. stem dia.)	4
3	LW-11795	SPRING, Valve, inner	8
4	LW-11800	SPRING, Valve, outer	8
6	LW-13323	SEAT, Valve spring lower, exhaust	4
13	78524	SOCKET, Push rod, hydraulic tappet	8
14	68987	TUBE, Push rod, shroud	

O-320-E2G

SECTION 3 (CONT.)
CYLINDER, PISTON AND VALVE TRAIN

Page 3-3 (Cont.)

Ref. No.	Part No.	Description	Qty. Per Assy.
16	LW-13428	SPRING, Shroud tube	4
17	LW-12272	LOCKPLATE, Shroud tube	4
19	62922	SEAL, Shroud tube	8

For all other parts applicable to O-320-E2G model engines, use column headed -E2D. Do not use figure reference number 15. Disregard note for 7/16 in. stem dia. exhaust valves.

Page 3-4

6	LW-13790	SHAFT, Valve rocker	4
	LW-12892	THRUST BUTTON, Rocker shaft	8
	74887	SPACER, 0.52 ID x 7/8 OD x 3/8 in. thick	2
15	STD-2090	NUT, Plain, 1/2-20	18
18	STD-2174	CLAMP, 5/8 in. dia.	4
20	61363	PIPE, Intake, cylinders #1 and #2	2
	61365	PIPE, Intake, cylinder #3	1
	61364	PIPE, Intake, cylinder #4	1
21	STD-1196	HOSE, 1-1/2 in. ID x 1-7/8 OD x 1-1/2 in. long	4
22	STD-1530	CLAMP, Hose, 1-3/4 ID x 9/16 in. wide	8

For all other parts, except those listed above, applicable to O-320-E2G model engines, use column headed -E2D.

SECTION 4
IGNITION SYSTEM

Page 4-1

3	LW-12681	GASKET, Magneto	2
	STD-761	PIN, Cotter, 3/32 in. dia. x 1.00 in. long	1
4	LW-12706	ADAPTER, Magneto, impulse coupling	1
	76734	ZIP STRAPS	8

For all other parts, except those listed above, applicable to O-320-E2G model engines, use column headed -E2D.

Page 4-2

This page is not applicable to O-320-E2G model engines.

O-320-E2G

SECTION 4 (CONT.)
IGNITION SYSTEM

Page 4-3

Ref. No.	Part No.	Description	Qty. Per Assy.
----------	----------	-------------	----------------

This page is not applicable to O-320-E2G model engines.

Page 4-4

This page is not applicable to O-320-E2G model engines.

Page 4-5

This page is not applicable to O-320-E2G model engines.

Page 4-6

This page is not applicable to O-320-E2G model engines.

Page 4-7

2	1182-B6	SPARK PLUG,Champion (EM41E)	8
3	STD-295	GASKET,Spark plug	8

SECTION 5
ELECTRICAL SYSTEM

Page 5-1

This page is not applicable to O-320-E2G model engines.

Page 5-2

38	STD-1858	BOLT,Hex.hd.,drilled,5/16-18 x 29/32 long	1
----	----------	---	---

For all other parts,except that listed above,applicable to O-320-E2G model engines,use column headed -E2D.

Page 5-3

O-320-E2G model engines are shipped without alternator assemblies.

Page 5-4

1	LW-14207	STARTER ASSY.,3.38:1 ratio,12/14 pitch pinion	1
4	STD-2156	BOLT,Hex.hd.,5/16-18 x 1-5/32 in.long	1

O-320-E2G

SECTION 5 (CONT.)
ELECTRICAL SYSTEM

Page 5-4 (Cont.)

Ref. No.	Part No.	Description	Qty. Per Assy.
----------	----------	-------------	----------------

O-320-E2G model engines are shipped without alternator drive belts and magnetic starter switches. All other parts, applicable to O-320-E2G model engines, except those listed on page 7, use column headed -E2D.

Page 5-5

O-320-E2G model engines are shipped without voltage regulators and relays.

SECTION 6
FUEL INDUCTION SYSTEM

Page 6-1

Only figure reference numbers 1 thru 5 under column -E2D are applicable to O-320-E2G model engines.

Page 6-2

Use carburetor Avco Lycoming P/N 78728, Marvel-Schebler P/N 10-5009, and all other parts under column headed -E2D for O-320-E2G model engines.

Page 6-3

This page is not applicable to O-320-E2G model engines. Use 4 P/N 1102 pipe plugs.

Page 6-4

This page is not applicable to O-320-E2G model engines.

Page 6-5

1	LW-12098-1-170	TUBE ASSY.,Cylinders 1 and 2	2
2	LW-12098-1-116	TUBE ASSY.,Cylinders 3 and 4	2
3	LW-12098-0-100	TUBE ASSY.,Intermediate	2
4	LW-12293	CLIP,Cushion type,3/16 ID for 1/4 in. dia.screw	4
	71909	CLAMP,1-1/2 ID with 1/4 in.dia.offset	4

For all other parts, except those listed above, for O-320-E2G model engines, use column headed -E2D.

O-320-E2G

SECTION 7

COOLING BAFFLES, EXHAUST, OIL GAGES AND PROPELLER GOVERNOR OIL LINES

Page 7-1

Ref. No.	Part No.	Description	Qty. Per Assy.
----------	----------	-------------	----------------

For those parts applicable to O-320-E2G model engines use column headed -E2D.

Page 7-2

Use column headed -E2D for all parts applicable to O-320-E2G model engines.

Page 7-3

1	75736	TUBE, Oil level gage, long	1
2	72059	GASKET, Oil level gage	1
3	74068	RING, Oil level gage	1
4	LW-14758	GAGE ASSEMBLY, Oil level	1
5	72842	PLUG, Oil level gage	1
6	STD-366	PIN, 1/16 in. dia. x 7/16 in. long	1

Page 7-4

This page is not applicable to O-320-E2G model engines.

NOTE

Order seal and gasket kit Avco Lycoming P/N 69371-1 and cylinder, piston and ring kit, P/N 76659 for O-320-E2G model engines.